



US00D804602S

(12) **United States Design Patent** (10) **Patent No.:** **US D804,602 S**
Barfoot et al. (45) **Date of Patent:** **** Dec. 5, 2017**

(54) **FIREARM STOCK**

FOREIGN PATENT DOCUMENTS

(71) Applicant: **Magpul Industries Corp.**, Louisville, CO (US)

DE 29621379 U1 1/1997
DE 29721931 U1 1/1998

(Continued)

(72) Inventors: **Grady Barfoot**, Denver, CO (US);
Timothy Eric Roberts, Broomfield, CO (US); **Michael T. Mayberry**, Denver, CO (US)

OTHER PUBLICATIONS

PRS Gen3 Precision-Adjustable Stock, Magpul, [online], [site visited Sep. 30, 2016]. <URL: <https://www.magpul.com/products/prs-gen3-precision-adjustable-stock>>.*

(Continued)

(73) Assignee: **Magpul Industries Corp.**, Austin, TX (US)

(**) Term: **15 Years**

Primary Examiner — T. Chase Nelson

Assistant Examiner — Jonathan J Han

(21) Appl. No.: **29/551,313**

(74) *Attorney, Agent, or Firm* — Neugeboren O'Dowd PC

(22) Filed: **Jan. 12, 2016**

(57) **CLAIM**

The ornamental design for a firearm stock, as shown and described.

(51) **LOC (10) Cl.** **22-01**

(52) **U.S. Cl.**
USPC **D22/108**

DESCRIPTION

(58) **Field of Classification Search**

USPC D22/108, 103, 109, 100, 101, 104, 105, D22/110; D21/401, 461, 567, 568, D21/570-575; 124/16, 26, 27, 28, 29, 124/54, 73-77; 222/78, 79; 42/54, 57, 42/58, 71.01, 72, 73, 74, 75.03, 90; 446/23, 182, 192, 401, 403, 405-407, 446/473, 475

CPC F41C 23/00; F41C 23/02; F41C 23/04; F41C 23/06; F41C 23/08; F41C 23/10; F41C 23/12; F41C 23/14; F41C 23/16; F41C 23/18; F41C 23/20; F41C 23/22;

(Continued)

FIG. 1 is a left, top, front perspective view of a firearm stock showing our new design;
FIG. 2 is a left, top, front perspective view of the firearm stock of FIG. 1;
FIG. 3 is a top view of the firearm stock of FIG. 1;
FIG. 4 is a left side elevation view of the firearm stock of FIG. 1;
FIG. 5 is a right side elevation view of the firearm stock of FIG. 1; and,
FIG. 6 is a bottom view of the firearm stock of FIG. 1.

The shade lines in the Figures show contour and not surface ornamentation.

The dashed broken lines showing portions of the design in all figures are included for the purpose of illustrating environment and unclaimed features and forms no part of the claimed design. The dot-dash broken lines showing portions of the design in all figures are included for the purpose of showing a boundary to areas marked with surface shading and forms no part of the claimed design.

(56) **References Cited**

U.S. PATENT DOCUMENTS

5,367,812 A 11/1994 Lautrec
5,375,360 A 12/1994 Vatterott

(Continued)

1 Claim, 4 Drawing Sheets

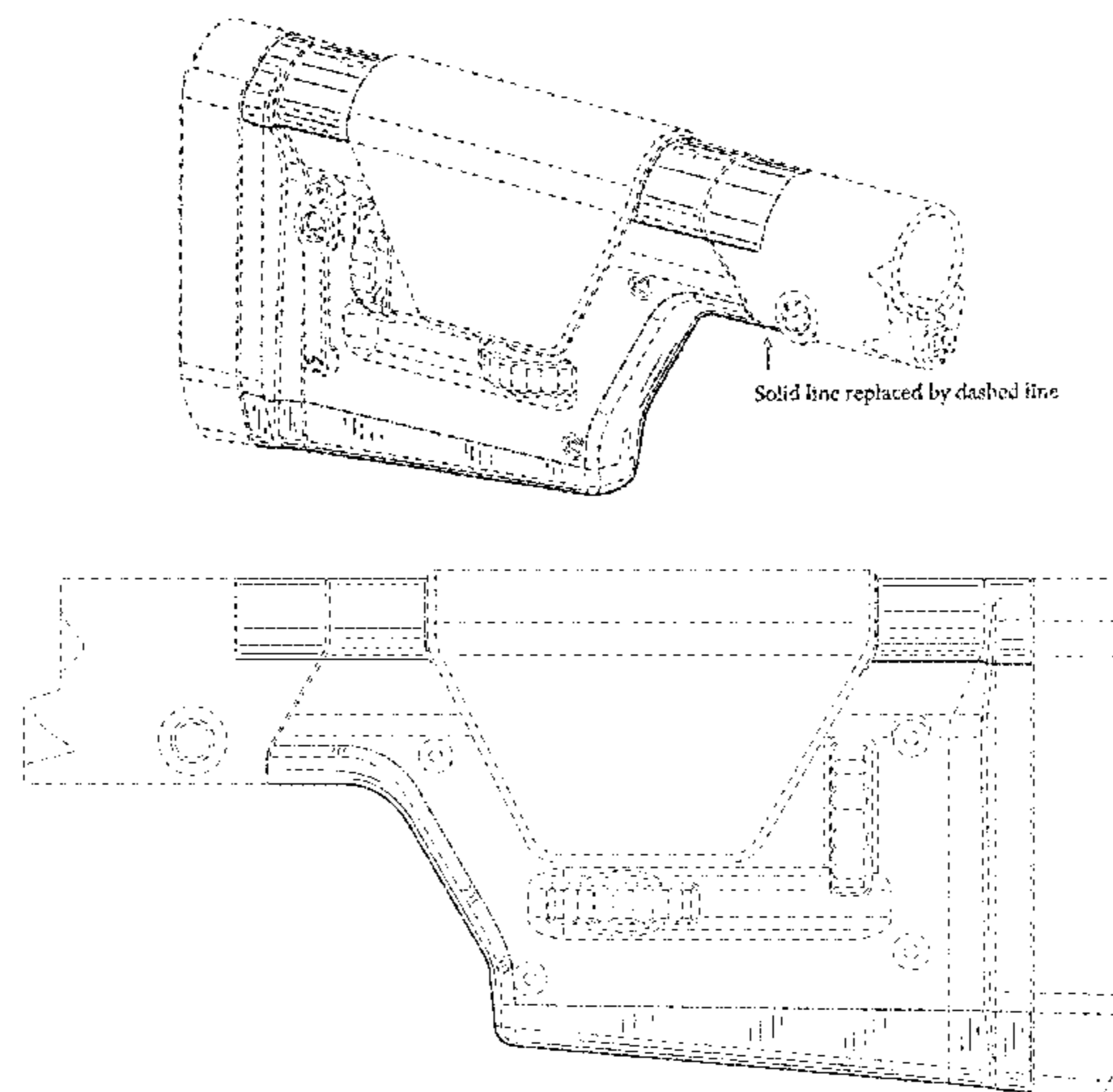

(58) **Field of Classification Search**
 CPC F41C 7/02; F41C 7/04; F41C 7/06; F41C
 7/11; F41C 7/12; F41C 27/00; F41C
 27/06
 See application file for complete search history.

(56) **References Cited**
 U.S. PATENT DOCUMENTS

5,933,997 A 8/1999 Barrett
 5,970,642 A 10/1999 Martin
 6,012,246 A 1/2000 Robinson et al.
 6,457,273 B2 10/2002 Beretta
 6,553,707 B1 4/2003 Tseng
 6,594,935 B2 7/2003 Beretta
 6,598,329 B1 7/2003 Alexander
 6,651,371 B2 11/2003 Fitzpatrick et al.
 6,684,549 B2 2/2004 Bragg
 6,874,267 B2 4/2005 Fitzpatrick et al.
 6,889,461 B2 5/2005 Vignaroli et al.
 6,925,743 B1 8/2005 DiGiovanna
 6,925,744 B2 8/2005 Kincel
 7,104,001 B1 9/2006 DiGiovanna
 7,104,002 B2 9/2006 Rotundo
 7,152,355 B2 12/2006 Fitzpatrick et al.
 7,162,822 B1 1/2007 Heayn et al.
 7,337,573 B1 3/2008 DiGiovanna
 D567,895 S * 4/2008 Cauley D22/103
 7,386,952 B1 6/2008 Henretty
 7,398,616 B1 7/2008 Weir
 7,418,797 B1 9/2008 Crose
 7,428,794 B2 9/2008 Oz
 D584,373 S * 1/2009 Young D22/103
 7,478,495 B1 1/2009 Alzamora et al.
 7,523,579 B2 4/2009 Al-Mulla
 7,536,819 B2 5/2009 Popikow
 D600,307 S * 9/2009 Fitzpatrick D22/109
 D603,013 S * 10/2009 Fitzpatrick D22/108
 7,640,688 B2 1/2010 Oz
 7,647,719 B2 1/2010 Fitzpatrick et al.
 D616,056 S * 5/2010 Bentley D22/108
 7,743,544 B2 6/2010 Laney et al.
 7,762,018 B1 7/2010 Fitzpatrick et al.
 7,802,392 B2 * 9/2010 Peterson F41A 11/02
 42/124
 7,805,873 B2 10/2010 Bentley
 D626,618 S * 11/2010 Peterson D22/103
 D629,062 S * 12/2010 Peterson D22/103
 7,849,626 B2 12/2010 Fluhr
 D634,388 S * 3/2011 Peterson D22/108
 D636,834 S * 4/2011 Mayberry D22/108
 7,930,849 B2 4/2011 Abraham et al.
 D638,887 S * 5/2011 En D21/573
 D641,824 S * 7/2011 Gridelet D22/103
 D641,825 S * 7/2011 Gridelet D22/103
 7,984,580 B1 7/2011 Giauque et al.
 D643,085 S * 8/2011 Peterson D22/103
 D645,532 S * 9/2011 Peterson D22/103
 D645,533 S * 9/2011 Peterson D22/108
 8,087,193 B2 1/2012 Kincel
 8,186,090 B1 * 5/2012 Chiarolanza F41C 23/04
 42/73
 8,191,299 B2 6/2012 Faifer
 8,296,984 B2 10/2012 Kincel
 8,341,868 B2 1/2013 Zusman
 8,381,427 B2 2/2013 Nill
 8,387,298 B2 3/2013 Kincel
 8,397,414 B2 3/2013 Walters
 D679,772 S * 4/2013 Mossberg, Jr. D22/103
 8,429,844 B2 4/2013 Dextraze et al.
 D682,973 S * 5/2013 KasanJian-King D22/108
 8,453,365 B1 6/2013 Ballard
 8,464,458 B2 6/2013 Chvala
 8,499,483 B2 8/2013 Quaedpeerdes et al.
 8,505,226 B2 8/2013 Vesligaj
 8,522,465 B2 9/2013 Jarboe et al.
 8,555,541 B2 10/2013 Ingram

8,601,736 B2 12/2013 Andersson
 D702,797 S * 4/2014 Donnelly D22/108
 D704,294 S * 5/2014 Jarboe D22/108
 8,720,099 B1 5/2014 Sisk
 8,763,296 B1 7/2014 Chvala
 8,776,423 B2 7/2014 Paquette
 8,782,941 B2 7/2014 Zusman
 8,789,306 B1 7/2014 Mazzoni
 8,815,138 B2 8/2014 Howe et al.
 8,826,577 B1 * 9/2014 Bentley F41C 23/22
 42/49.01
 8,844,185 B2 9/2014 Jarboe
 D722,672 S * 2/2015 Juarez D22/108
 D723,128 S * 2/2015 Hu D22/103
 8,943,728 B2 * 2/2015 Ward F41C 23/22
 42/71.01
 8,955,245 B2 2/2015 Chvala
 D733,247 S * 6/2015 Lewis D22/108
 9,052,155 B2 6/2015 Fluhr et al.
 9,109,855 B1 8/2015 Kincel
 9,121,663 B2 9/2015 Troy et al.
 9,157,696 B2 * 10/2015 Dextraze F41G 11/003
 D745,627 S * 12/2015 Kielsmeier D22/108
 D749,181 S * 2/2016 Hu D22/103
 D760,858 S * 7/2016 Formanes D22/108
 2006/0254111 A1 11/2006 Giauque et al.
 2007/0101631 A1 5/2007 Bentley
 2008/0168695 A1 * 7/2008 Nakayama F41A 21/481
 42/75.02
 2008/0236016 A1 * 10/2008 Fitzpatrick F41C 23/14
 42/71.01
 2010/0115817 A1 5/2010 Faifer
 2010/0229444 A1 9/2010 Faifer
 2010/0242334 A1 9/2010 Kincel
 2010/0307042 A1 * 12/2010 Jarboe F41A 3/18
 42/6
 2011/0173863 A1 7/2011 Ingram
 2012/0036751 A1 2/2012 Wang et al.
 2012/0036757 A1 2/2012 LaRue
 2012/0186124 A1 7/2012 Kincel
 2013/0036645 A1 2/2013 Chvala
 2013/0097911 A1 4/2013 LaRue
 2013/0326924 A1 12/2013 Jarboe et al.
 2014/0075815 A1 * 3/2014 Jarboe F41C 23/04
 42/73
 2014/0137456 A1 5/2014 Chiang
 2014/0190055 A1 7/2014 Warburton
 2014/0190056 A1 7/2014 Troy et al.
 2014/0196343 A1 7/2014 Wilson et al.
 2014/0245649 A1 9/2014 Fluhr et al.
 2014/0259848 A1 9/2014 Chvala
 2015/0052795 A1 2/2015 Burke et al.
 2015/0338186 A1 11/2015 Hopkins
 2016/0116250 A1 * 4/2016 Mather F41A 3/66
 42/73
 2016/0178314 A1 * 6/2016 Kielsmeier F41C 23/14
 42/73
 2016/0202016 A1 7/2016 Mather et al.
 2016/0209161 A1 * 7/2016 Wilson F41C 23/04

FOREIGN PATENT DOCUMENTS

DE 202005001766 U1 6/2006
 DE 202011052542 U1 2/2012
 RU 2088881 C1 8/1997

OTHER PUBLICATIONS

PRS Precision-Adjustable Stock—SR25/M110, Magpul, [online], [site visited Sep. 30, 2016]. <URL: <https://www.magpul.com/products/prs-precision-adjustable-stock-sr25-m110>>.*
 Magpul PRS AR15/M16 Sniper Stock—Olive Drab Green, PrimaryArms.com, product review by John Gaddis posted Aug. 10, 2015, [online], [site visited on Sep. 30, 2016]. <URL: <http://www.primaryarms.com/magpul-prs-ar15m16-sniper-stock-olive-drab-green/p/mag307od>>.*

(56)

References Cited

OTHER PUBLICATIONS

LUTH-AR Adjustable Carbine Stock (MBA-3), Wing Tactical, [online], [site visited Sep. 30, 2016]. <URL: <http://www.wingtactical.com/firearm-parts/ar-15/stocks-accessories/luth-ar-adjustable-carbine-stock-mba-3/>>.*

Stock Exchange: Top 11 AR Stock Upgrades, Tactical-Life, by Robert A. Sadowski, posted May 12, 2015, [online], [site visited Sep. 30, 2016]. <URL: <http://www.tactical-life.com/gear/top-11-ar-stock-upgrades/#stocks-twml5-tacstar>>.*

Brownells—AR .308 PRS Stock Assy Collapsible Rifle Length, Brownells, [online], [site visited Sep. 30, 2016]. <URL: <http://www.brownells.com/rifle-parts/stock-parts/buttstocks/ar-308-prs-stock-assy-collapsible-rifle-length-blk-sku078000211-72284-139070.aspx?gdfms=52177F0E197A4AF9A201575860A34932&avad=avant&aid>>.*

AR-15 AMRS “Adjustable Match Rifle Stock”, TacStar, [online], [site visited Sep. 30, 2016]. <URL: <http://www.tacstar.com/home/ar15stock.php>>.*

LMT DMR556 Stock on Sale at Weapon Outfitters, AR15news.com, posted on Oct. 6, 2014 by ar15news, [online], [site visited Sep. 30, 2016]. <URL: <http://www.ar15news.com/2014/10/06/lmt-dmr556-stock-sale-weapon-outfitters/>>.*

Modular Driven Technologies Corp., “Adjustable Recoil Pad Assembly for PRS”, Website located at <http://mdttac.com/adjustable-prs.html>, Known to exist as early as Dec. 17, 2015, p. 3.

Modular Driven Technologies Corp., “Adjustable Recoil Pad Assembly for UBR”, Website located at <http://mdttac.com/adjustable-ubr.html>, Known to exist as early as Dec. 17, 2015, p. 2.

BGALLAHER77, “AR-15 A2 Stock Install”, Website located at <https://www.youtube.com/watch?v=FyTfkd157e8>, Jan. 4, 2013, p. 2.

Brownells, Inc., “Ar-15/M16 Mil—Spec Buffer Tube”, Website located at <http://www.brownells.com/rifle-parts/receiver-parts/buffer-tube-parts/buffer-tubes/ar-15-m16-mil-spec-buffer-tube-sku080001046-5706>, Known to exist as early as Feb. 2, 2015, p. 2.

Brownells, Inc., “AR15/M16 A1 Rifle Buffer Tube Assembly”, Website located at <http://www.brownells.com/rifle-parts/receiver-parts/buffer-tube-parts/buffer-tubes/ar-15-m16-stock-completion-kits-prod27315.aspx>, Known to exist as early as Feb. 2, 2015, p. 2.

Brownells, Inc., “Changing Standard Butt Stock to Collapsible”, Website located at <http://www.brownells.com/.aspx/lid=10364/GunTechdetail/Changing-Standard-Butt-Stock-To-Collapsible>, Known to exist as early as Feb. 2, 2015, p. 4.

Lewis Machine & Tool Company, Inc., “DMR556”, Website located at <http://www.lmtstore.com/dmr556.html>, Known to exist as early as Dec. 17, 2015, p. 1.

Fulton Armory, “Fulton Armory M14 EBR-RI”, Website located at <http://www.fulton-armory.com/fultonarmoryusrifecal762mmm14-1-1-1-1-1-2.aspx>, Known to exist as early as Dec. 17, 2015, p. 2.

Fulton Armory, “Fulton Armory M25 Peerless Sniper Rifle”, Website located at <http://www.fulton-armory.com/>

[fultonarmoryusrifecal762mmm14-1-1-1-1-2-2-2.aspx](http://www.fulton-armory.com/fultonarmoryusrifecal762mmm14-1-1-1-1-2-2-2.aspx), Known to exist as early as Dec. 17, 2015, p. 2.

Fulton Armory, “Fulton Armory M39 EMR”, Website located at <http://www.fulton-armory.com/fultonarmoryusrifecal762mmm14-1-1-1-1-1-2-1.aspx>, Known to exist as early as Dec. 17, 2015, p. 2.

Fulton Armory, “Fulton Armory MK 14 Mod 0 EBR”, Website located at <http://www.fulton-armory.com/fultonarmoryusrifecal762mmm14-1-1-1-1-1-1-1.aspx>, Known to exist as early as Dec. 17, 2015, p. 2.

Fulton Armory, “Fulton Armory MK 14 Mod 2”, Website located at <http://www.fulton-armory.com/fultonarmoryusrifecal762mmm14-1-1-1-1-1-3.aspx>, Known to exist as early as Dec. 17, 2015, p. 2.

Fulton Armory, “Stock, Sage Tactical Chassis, Complete M14 EBR”, Website located at <http://www.fulton-armory.com/stocksagetacticalcompletenoclipguidemount.aspx>, Known to exist as early as Dec. 17, 2015, p. 2.

Graco Corporation, “Adjustable Pad Plate”, Website located at <http://graco-corp.com/t/adjustable-pad-plate>, Known to exist as early as Dec. 17, 2015, p. 2.

Wikipedia, “Heckler & Koch PSG1”, Website located at https://en.wikipedia.org/wiki/Heckler_%26_Koch_PSG1, Known to exist as early as Dec. 17, 2015, p. 7.

JP Enterprises, “JP Adjustable Buttplate for Magpul PRS”, Website located at http://jprifles.com/1.1_feature.php, Known to exist as early as Dec. 17, 2015, p. 1.

Dustyatticx, “Magpul Fixed Carbine Stock Quickview”, Website located at <https://www.youtube.com/watch?v=inIH090KdpA>, Nov. 8, 2013, p. 2.

LUTH-AR, “The MBA/MBA-1 MODular Buttstock Assembly”, Website located at <http://www.luth-ar.com/product/the-mba-modular-buttstock-assembly/>, Known to exist as early as Dec. 17, 2015, p. 3.

Magpul Industries, Corp., “MOE Fixed Carbine Stock”, Website located at <https://www.magpul.com/products/moe-fixed-carbine-stock-commercial-spec>, Known to exist as early as Feb. 2, 2015, p. 5.

Magpul Industries, Corp., “PRS Precision-Adjustable Stock—AR15/M16”, Website located at <https://www.magpul.com/products/prs-precision-adjustable-stock-ar15-m16>, Known to exist as early as Dec. 17, 2015, p. 5.

Rock River Arms, Inc., “RRA Operator A2 Stock”, Website located at http://www.rockriverarms.com/index.cfm?fuseaction=category.display&category_id=540, Known to exist as early as Dec. 17, 2015, p. 2.

Star Gun Supply, “Sierra Precision AR 15 Adjustable Buttplate”, Website located at <http://www.stargunsupply.com/store/sierra-precision-ar-15-adjustable-buttplate-usa-canada.html>, Known to exist as early as Apr. 15, 2016, p. 6.

* cited by examiner

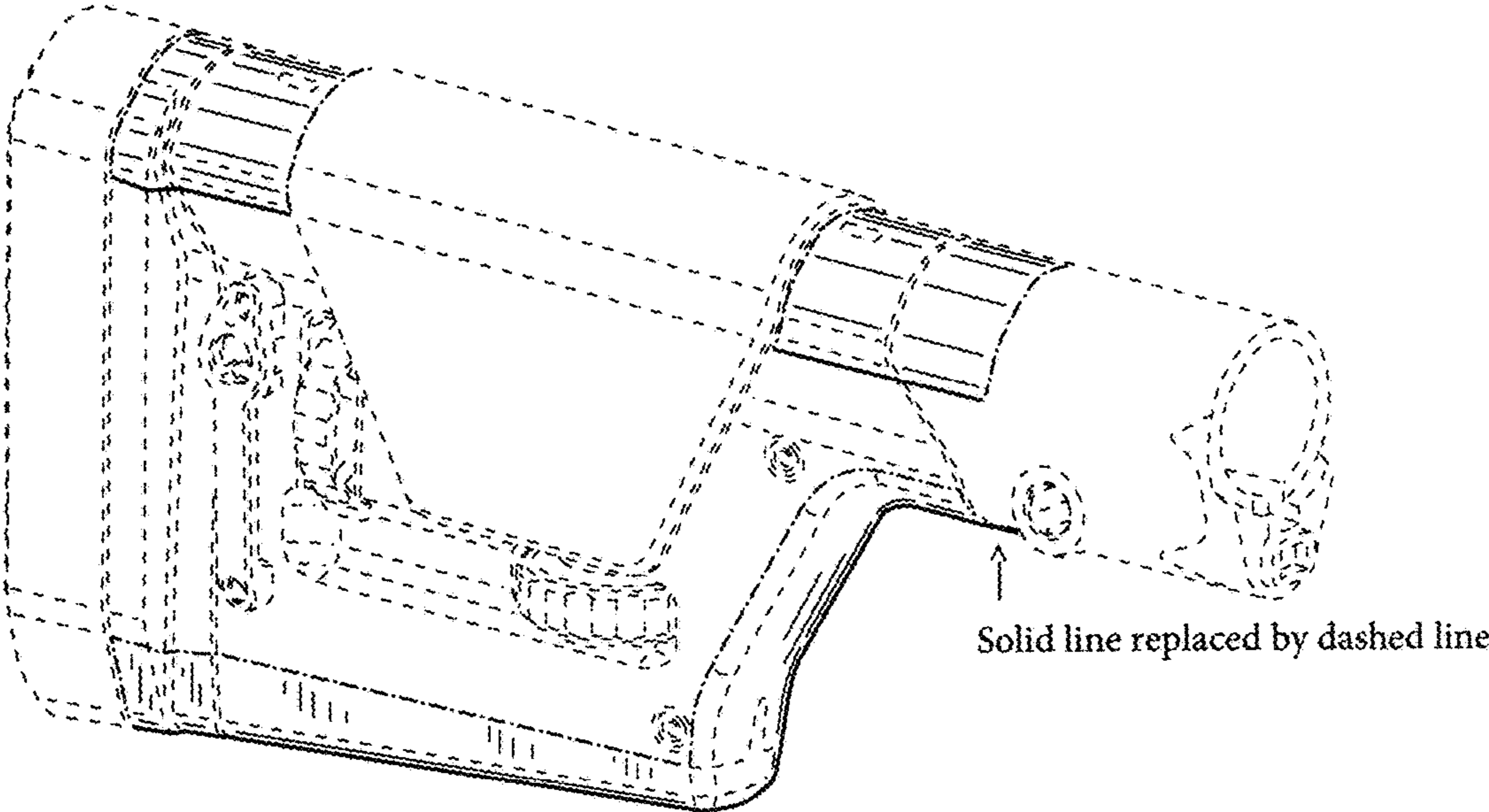

FIG.1

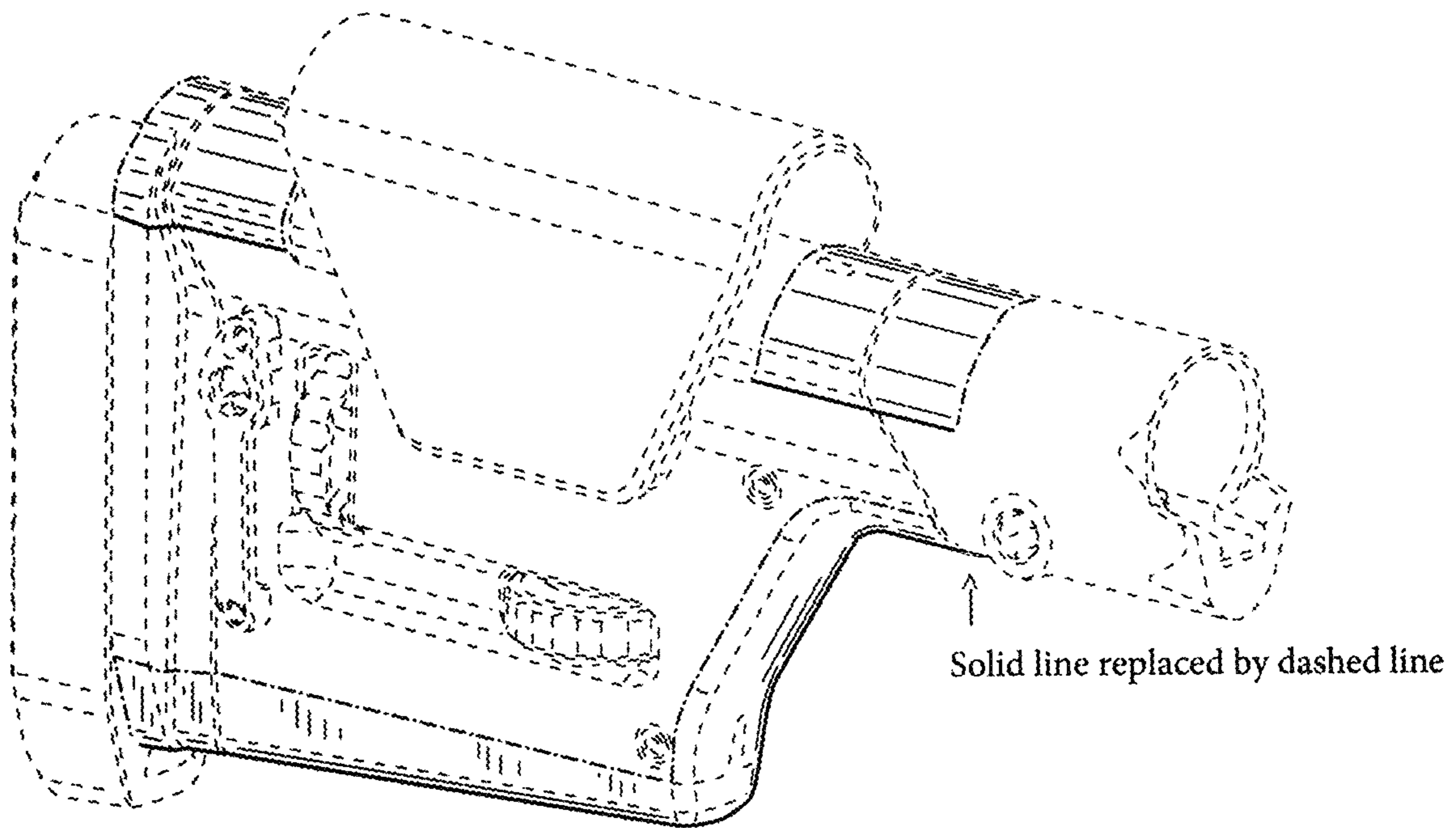

FIG.2

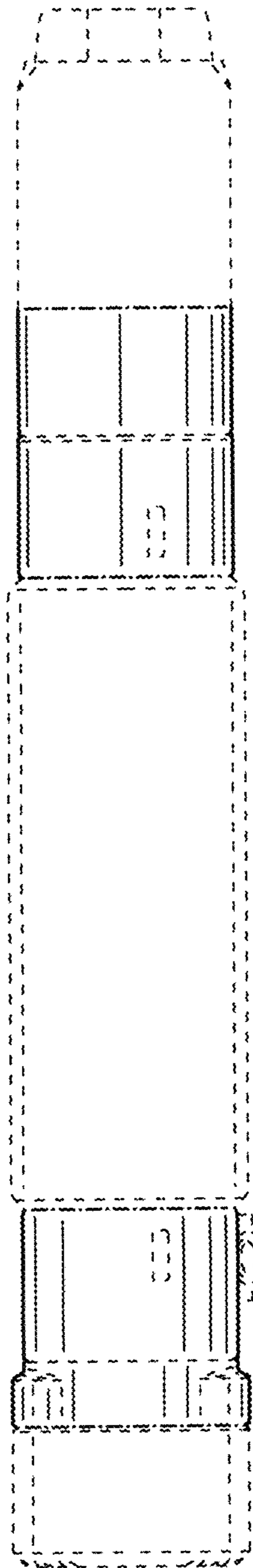

FIG.3

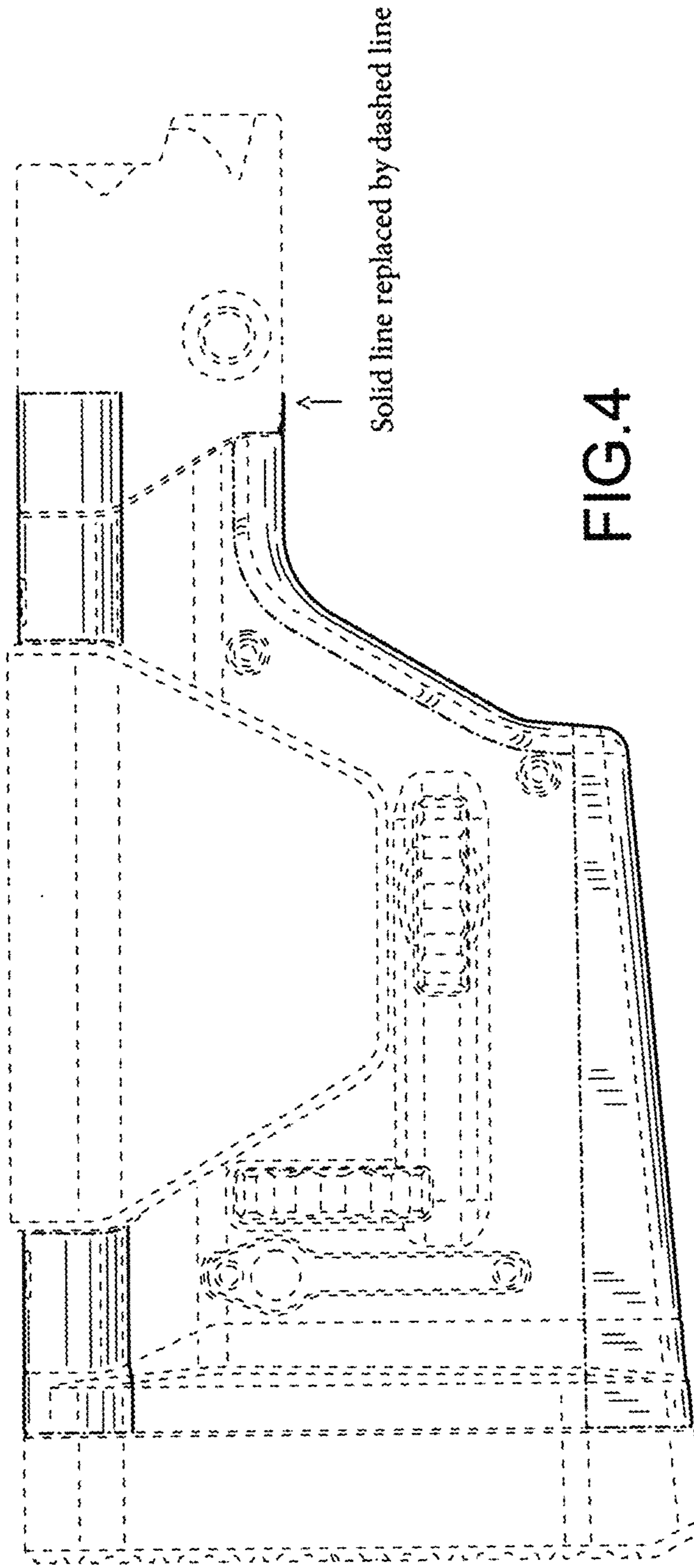

FIG.4

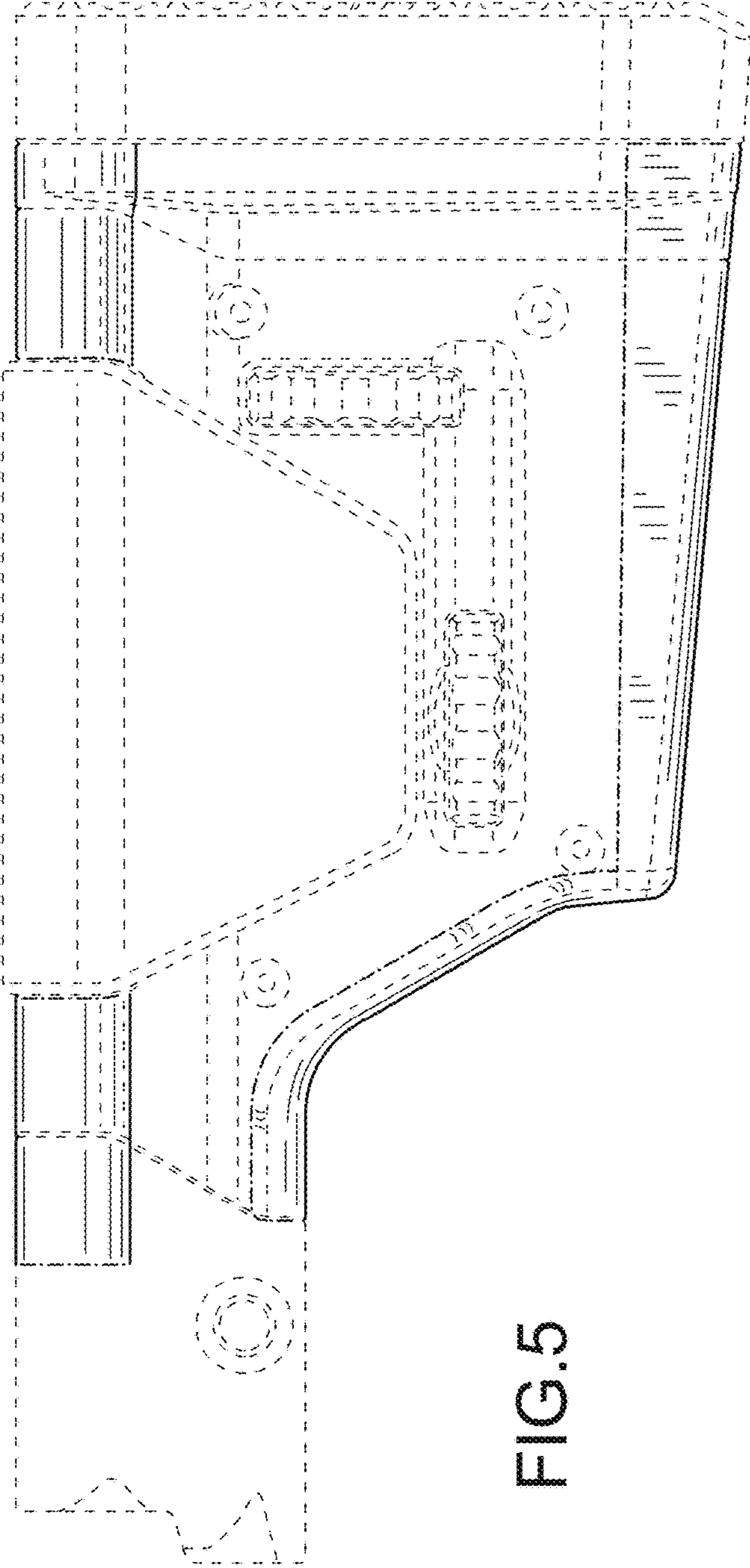

FIG. 5

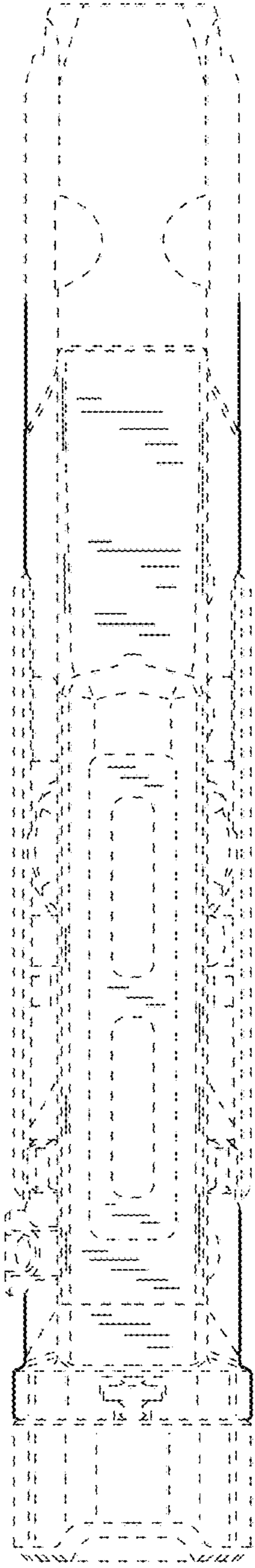

FIG. 6