



US00D804573S

(12) **United States Design Patent** (10) **Patent No.:** **US D804,573 S**
deWeber (45) **Date of Patent:** **** Dec. 5, 2017**

- (54) **EASEL**
- (71) Applicant: **deWeber Studios**, Woodland, WA (US)
- (72) Inventor: **Jennifer deWeber**, Woodland, WA (US)
- (73) Assignee: **deWeber Studios**, Woodland, WA (US)
- (**) Term: **15 Years**
- (21) Appl. No.: **29/559,543**
- (22) Filed: **Mar. 29, 2016**

Related U.S. Application Data

- (63) Continuation of application No. 29/540,274, filed on Sep. 22, 2015, now Pat. No. Des. 756,459.
- (51) **LOC (10) Cl.** **19-06**
- (52) **U.S. Cl.**
USPC **D19/106**
- (58) **Field of Classification Search**
USPC D19/106, 102; 248/460; 260/756;
206/1.8; 213/231

(Continued)

(56) **References Cited**

U.S. PATENT DOCUMENTS

- 815,810 A 3/1906 Goldsworthy et al.
- 2,586,524 A 2/1952 Dussardier et al.

(Continued)

OTHER PUBLICATIONS

Stutler, Russell, "Russell Stutler's Book About Sketching," at least as early as Jul. 27, 2015, http://www.stutler.cc/other/sketchbook/sketchbookde_c_04.html, 13 pages.

(Continued)

Primary Examiner — Cynthia Underwood

(74) *Attorney, Agent, or Firm* — Law Office of Karen Dana Oster, LLC

(57) **CLAIM**

I claim the ornamental design for an easel, as shown and described.

DESCRIPTION

FIG. 1 is a front perspective view of a second preferred easel shown in a folded closed configuration.

FIG. 2 is a back perspective of the easel of FIG. 1.

FIG. 3 is a top view of the easel of FIG. 1.

FIG. 4 is a bottom view of the easel of FIG. 1.

FIG. 5 is a front view of the easel of FIG. 1.

FIG. 6 is a back view of the easel of FIG. 1.

FIG. 7 is a first side view of the easel of FIG. 1.

FIG. 8 is a second side view of the easel of FIG. 1.

FIG. 9 is a front perspective view of the second preferred easel in a first open configuration with the painting compartment substantially parallel to the palette compartment.

FIG. 10 is a back perspective of the easel of FIG. 9.

FIG. 11 is a top view of the easel of FIG. 9.

FIG. 12 is a bottom view of the easel of FIG. 9.

FIG. 13 is a front view of the easel of FIG. 9.

FIG. 14 is a back view of the easel of FIG. 9.

FIG. 15 is a first side view of the easel of FIG. 9.

FIG. 16 is a second side view of the easel of FIG. 9.

FIG. 17 is a front perspective view of the second preferred easel in a second open configuration with an inner cover of the palette compartment open.

FIG. 18 is a back perspective of the easel of FIG. 17.

FIG. 19 is a top view of the easel of FIG. 17.

FIG. 20 is a bottom view of the easel of FIG. 17.

FIG. 21 is a front view of the easel of FIG. 17.

FIG. 22 is a back view of the easel of FIG. 17.

FIG. 23 is a first side view of the easel of FIG. 17.

FIG. 24 is a second side view of the easel of FIG. 17.

FIG. 25 is a front perspective view of the second preferred easel in a third open configuration with an inner cover of the palette compartment wrapped over the back of the palette compartment.

FIG. 26 is a back perspective of the easel of FIG. 25.

FIG. 27 is a top view of the easel of FIG. 25.

(Continued)

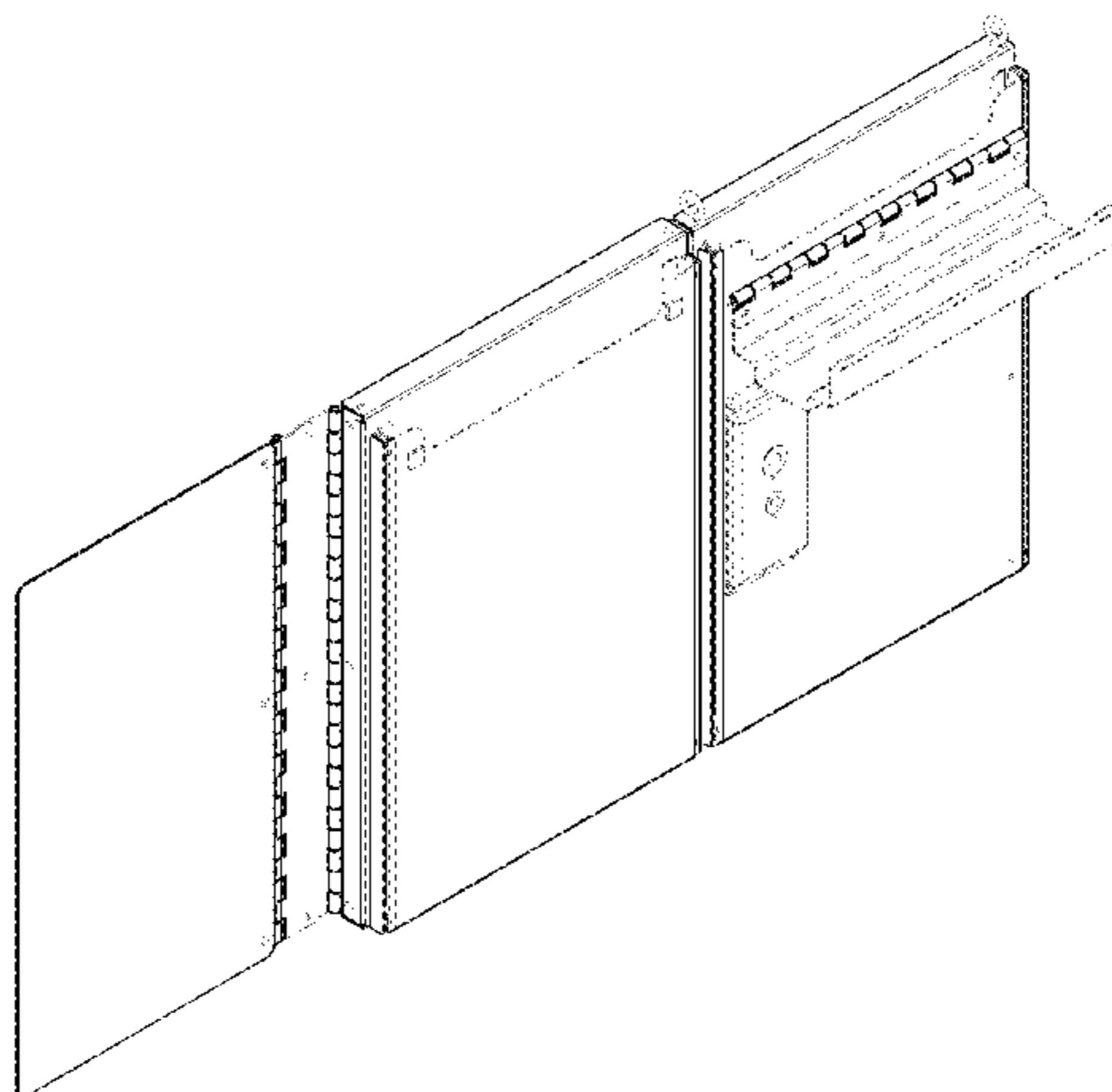

FIG. 28 is a bottom view of the easel of FIG. 25.
 FIG. 29 is a front view of the easel of FIG. 25.
 FIG. 30 is a back view of the easel of FIG. 25.
 FIG. 31 is a first side view of the easel of FIG. 25; and,
 FIG. 32 is a second side view of the easel of FIG. 25.
 The broken line depictions in the figures are included for environmental purposes and form no part of the claimed design.

1 Claim, 22 Drawing Sheets

(58) **Field of Classification Search**

CPC B44D 3/04; B44D 3/02
 See application file for complete search history.

(56) **References Cited**

U.S. PATENT DOCUMENTS

2,693,258	A	11/1954	Fleisch et al.	
2,751,271	A	6/1956	Henri et al.	
3,202,471	A *	8/1965	Wilson	A47B 97/08 24/335
4,057,215	A *	11/1977	Stettler	A47B 97/08 248/460
4,093,326	A	6/1978	Ford	
D251,213	S *	2/1979	Rodin	D19/106
4,335,812	A	6/1982	Koves	
4,372,630	A	2/1983	Fuhri	
4,638,909	A *	1/1987	Ford	B44D 3/04 206/1.7
4,662,518	A	5/1987	Chiappetta et al.	
4,856,856	A	8/1989	Winstone	
5,348,144	A	9/1994	Maier	

5,833,201	A *	11/1998	Graybill	A47B 97/08 248/460
6,012,696	A *	1/2000	Borie	A47B 97/08 248/461
D424,296	S	5/2000	David	
6,296,213	B1	10/2001	Law, III et al.	
6,619,474	B2 *	9/2003	Montgomery	B44D 3/02 206/1.5
6,745,988	B2	6/2004	Gelfand	
6,748,873	B2	6/2004	Brown, Sr.	
7,188,818	B2	3/2007	Chang	
7,455,275	B1 *	11/2008	Astadan	A47B 97/08 248/165
7,694,806	B2	4/2010	Huggins	
D649,040	S	11/2011	Sanders	
D653,854	S	2/2012	Chamberlain	
D687,096	S	7/2013	Taylor	
D701,699	S	4/2014	Bonacina et al.	
9,102,192	B2	8/2015	Taylor	
2005/0218011	A1 *	10/2005	Dewitt	B44D 3/04 206/1.7

OTHER PUBLICATIONS

Amazon.com, "Zen Art Supply Desktop Artist Easel Wooden Portable Stand Student Painting," at least as early as Jul. 27, 2015, <http://www.amazon.com>, 6 pages.
 Amazon.com, "Sienna Plein Air Artist Pochade Box Easel Large," at least as early as Jul. 27, 2015, <http://www.amazon.com>, 4 pages.
 Amazon.com, "Saunders Recycled Aluminum Snapak Form Holder, Letter Size, 9 x 12-inches (10517) : Clipboards : Office Products," at least as early as Jul. 31, 2015, <http://www.amazon.com>, 7 pages.
 Strada Designs, "Strada Easel," www.stradaeasel.com/pages/strada, at least as early as Sep. 22, 2015, 3 pages.

* cited by examiner

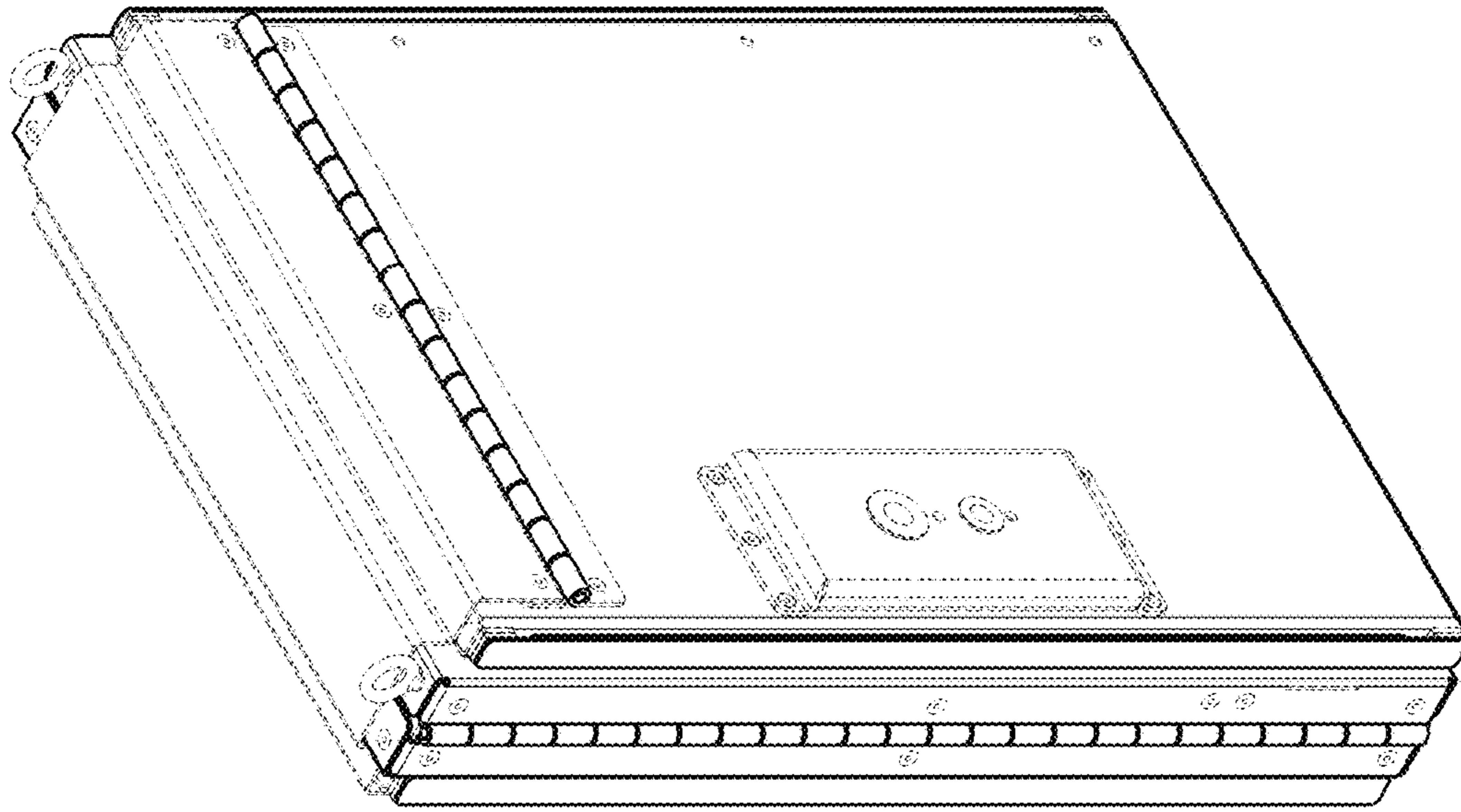

FIG. 2

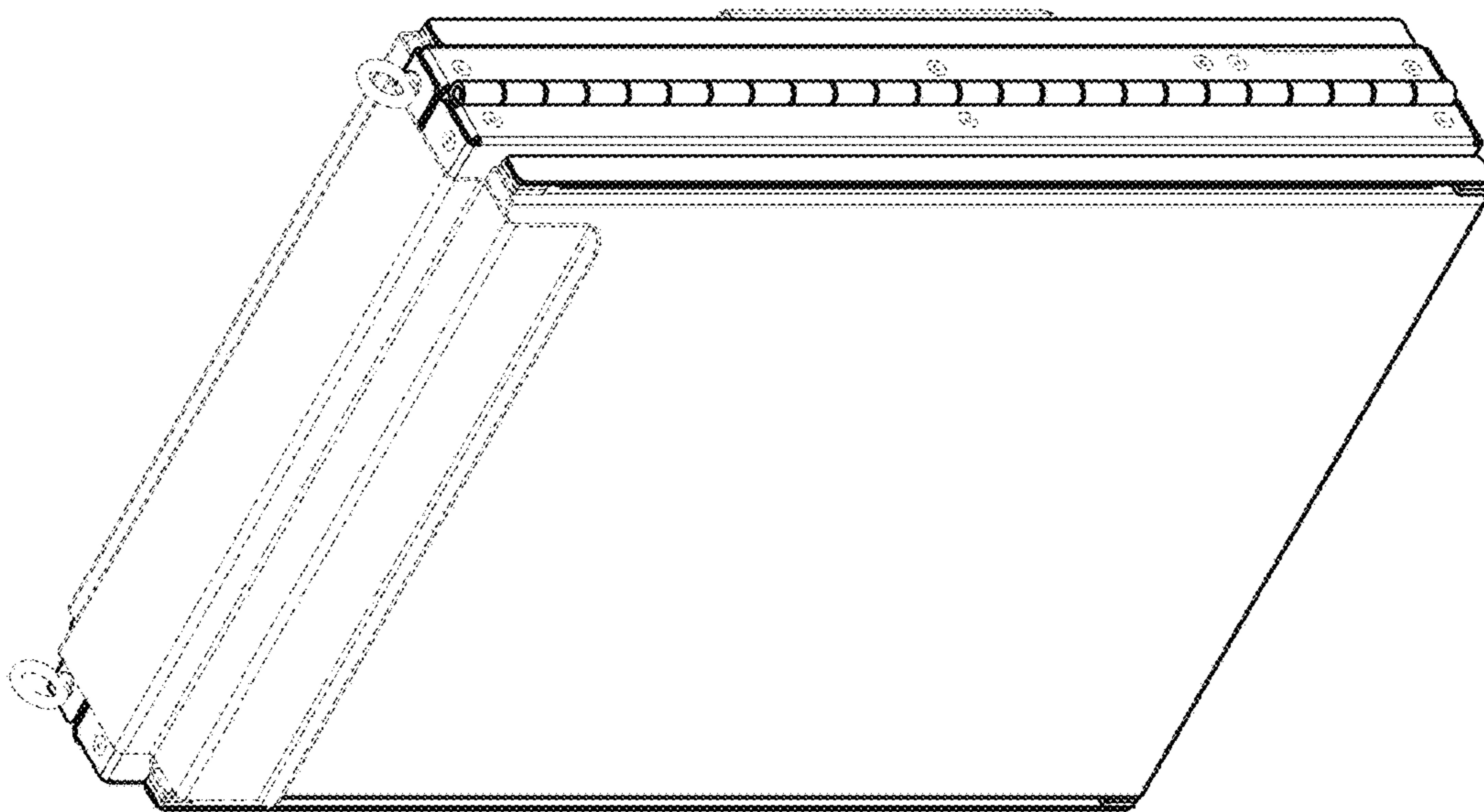

FIG. 1

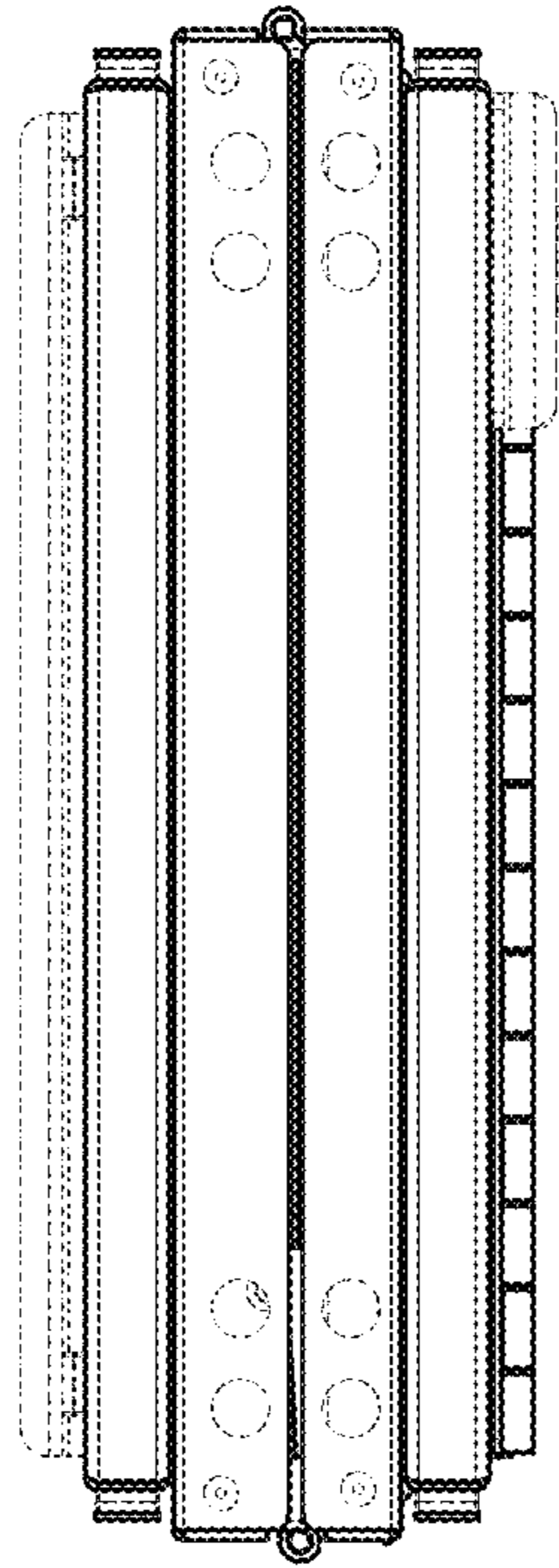

FIG. 4

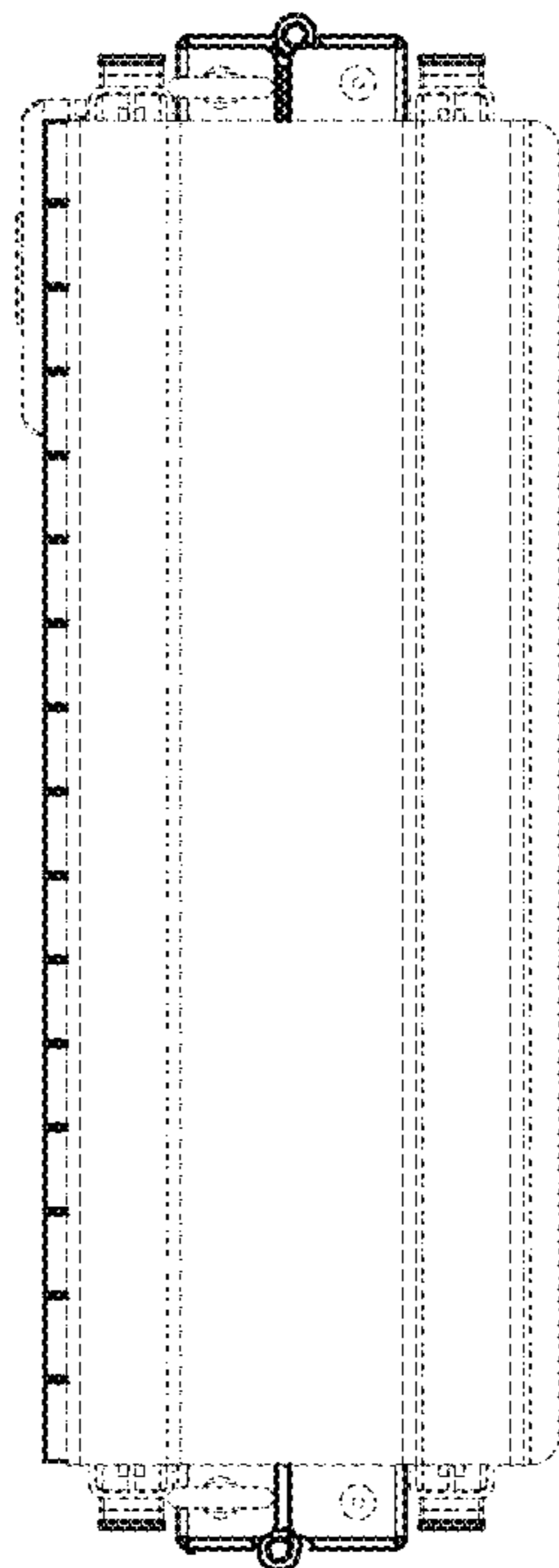

FIG. 3

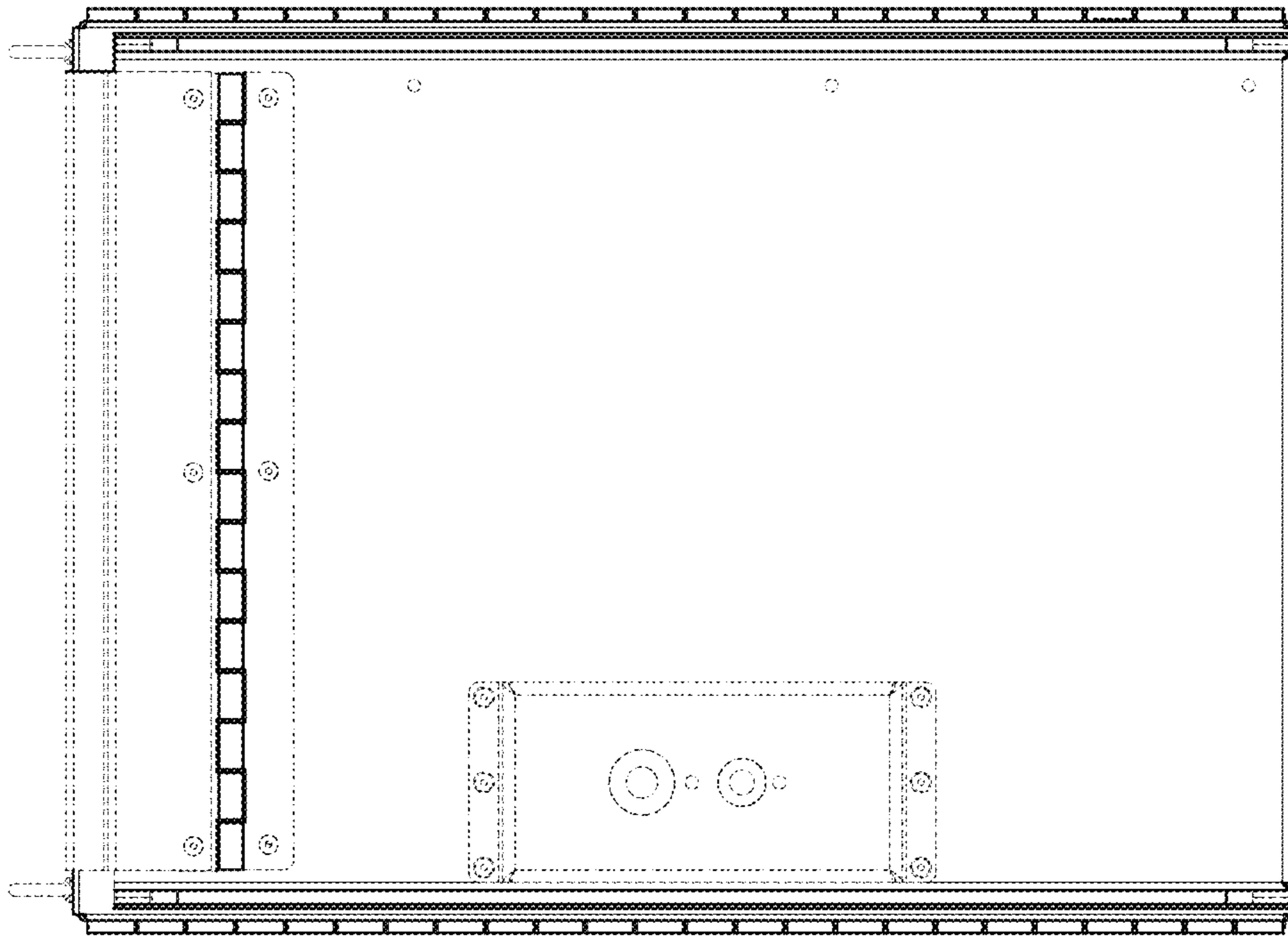

FIG. 6

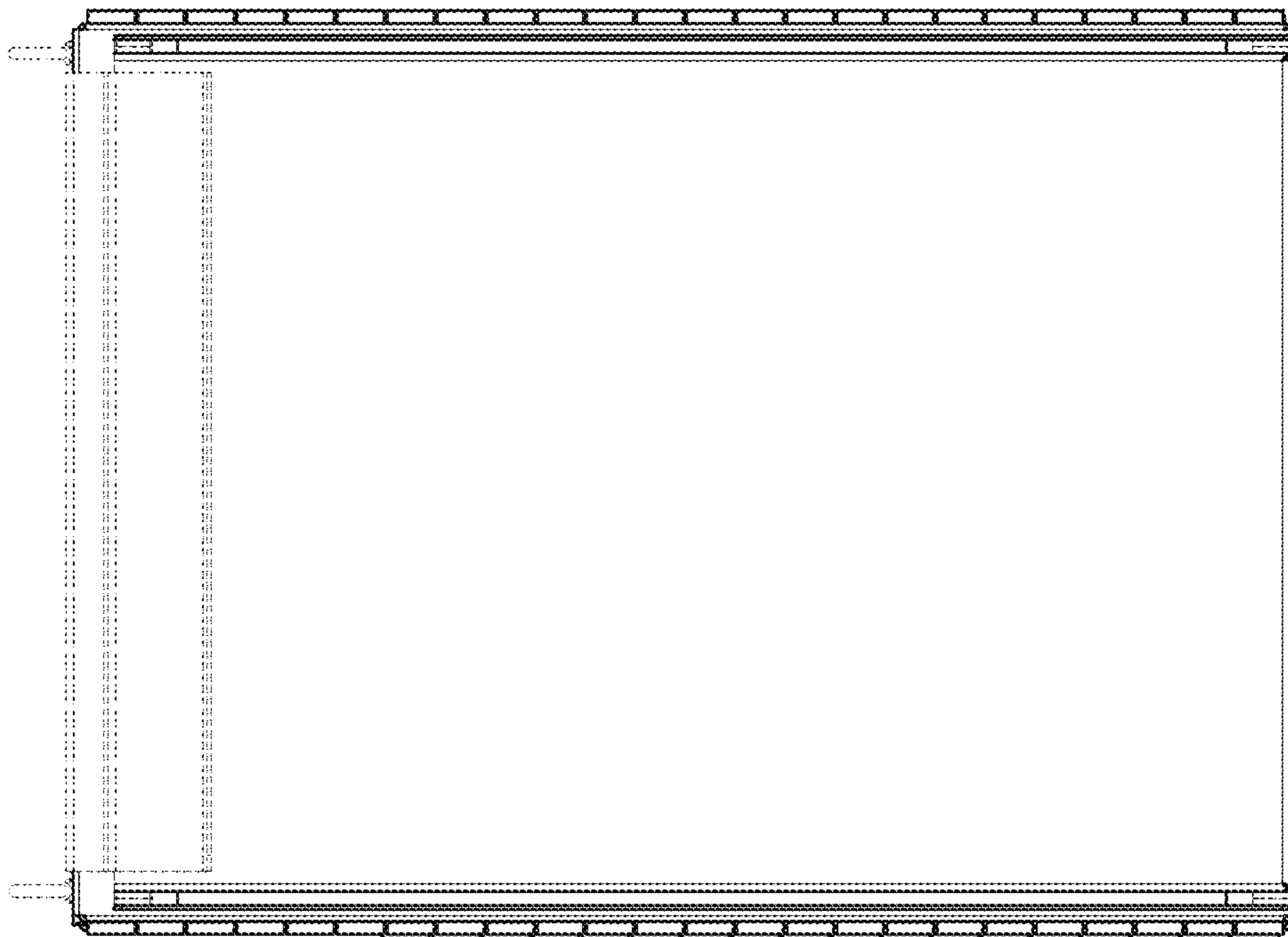

FIG. 5

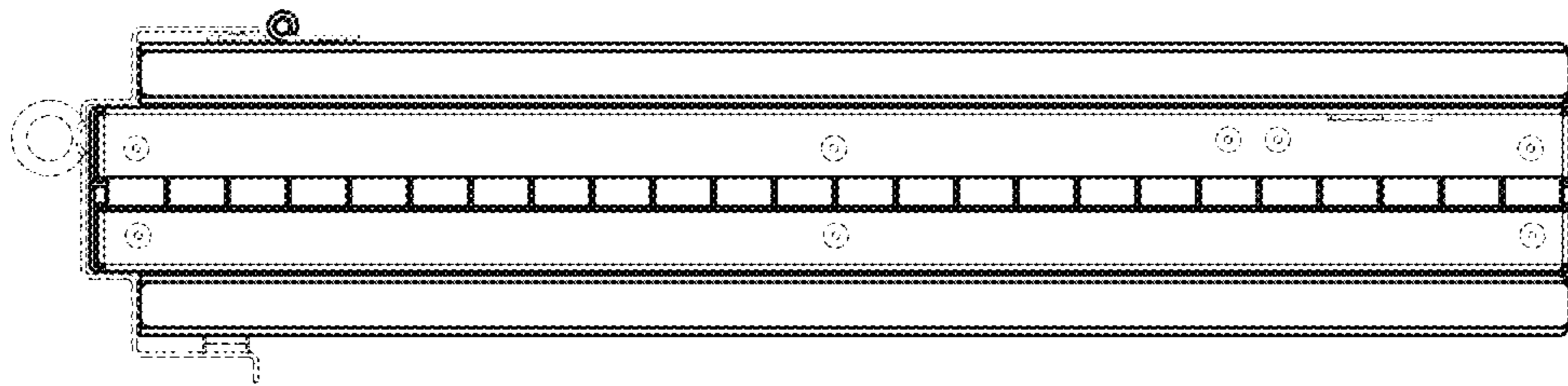

FIG. 8

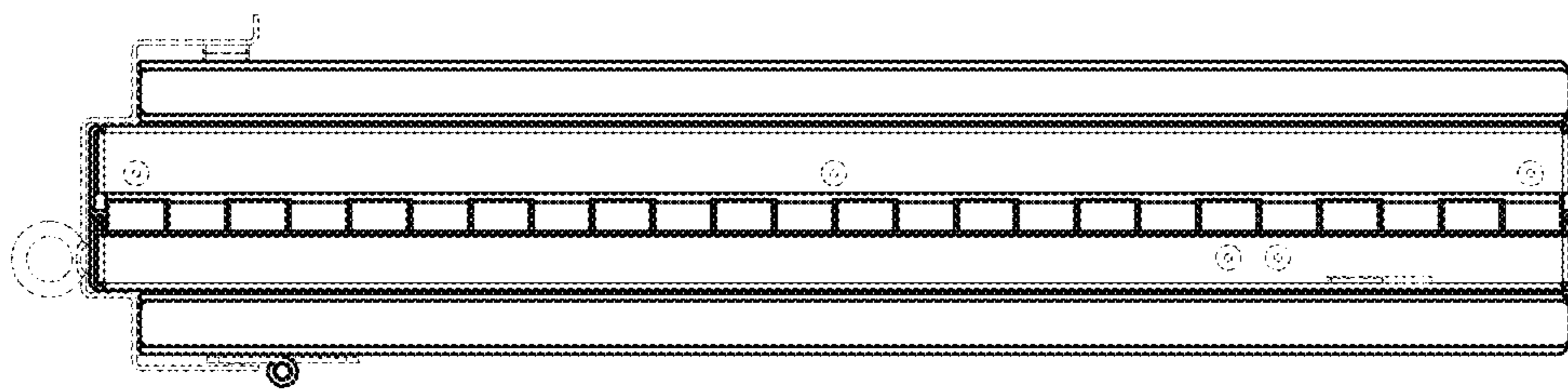

FIG. 7

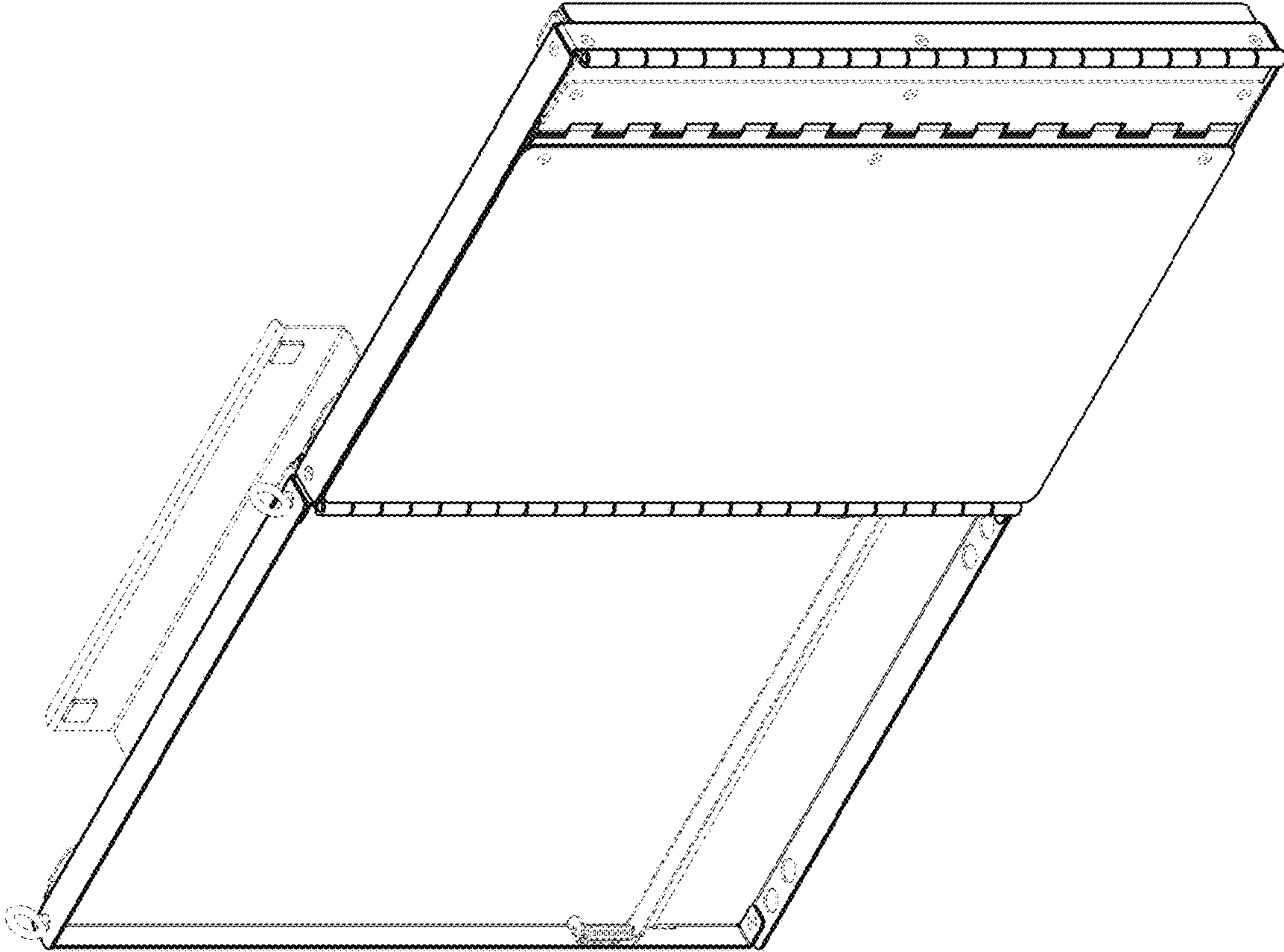
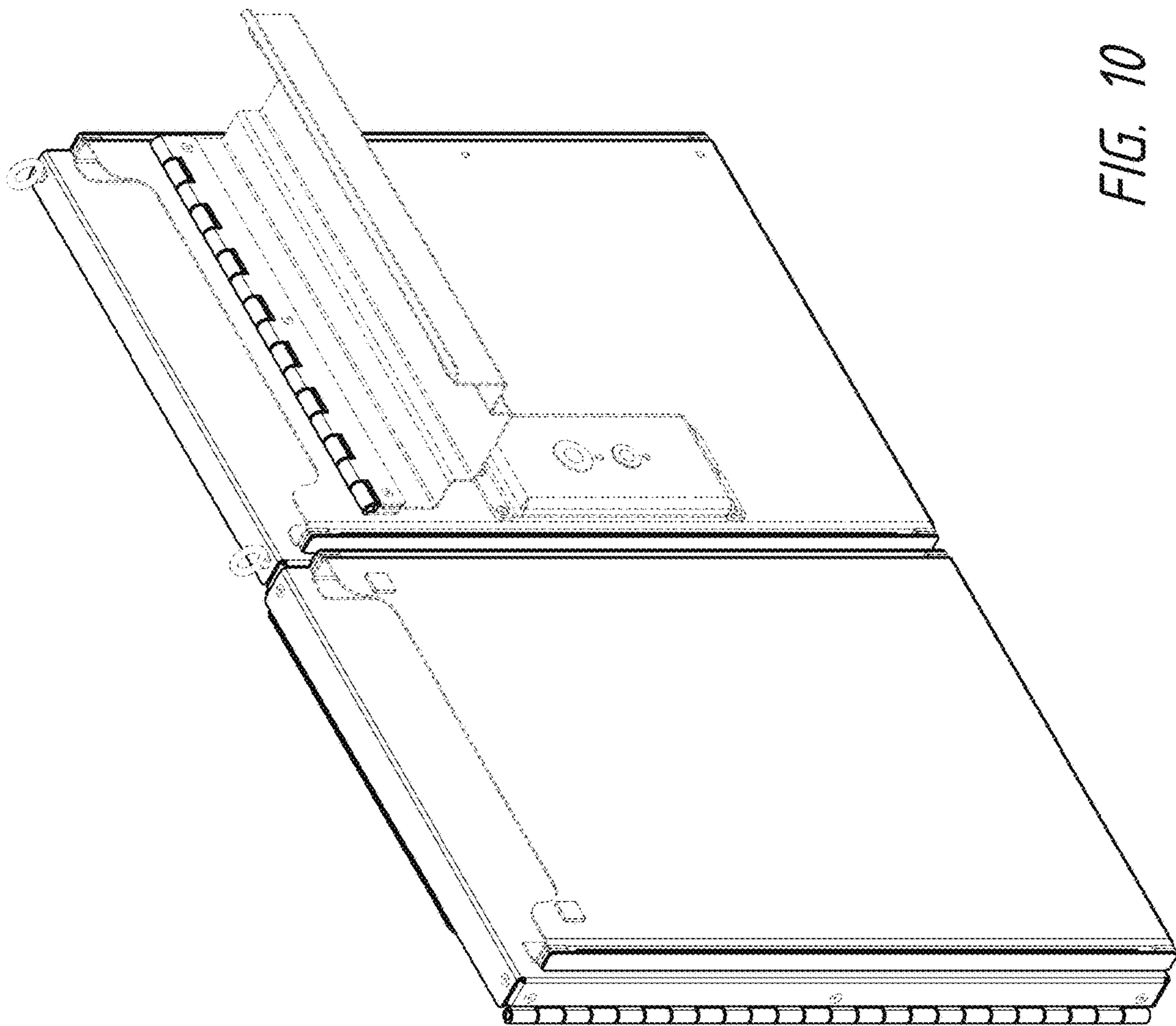

FIG. 9



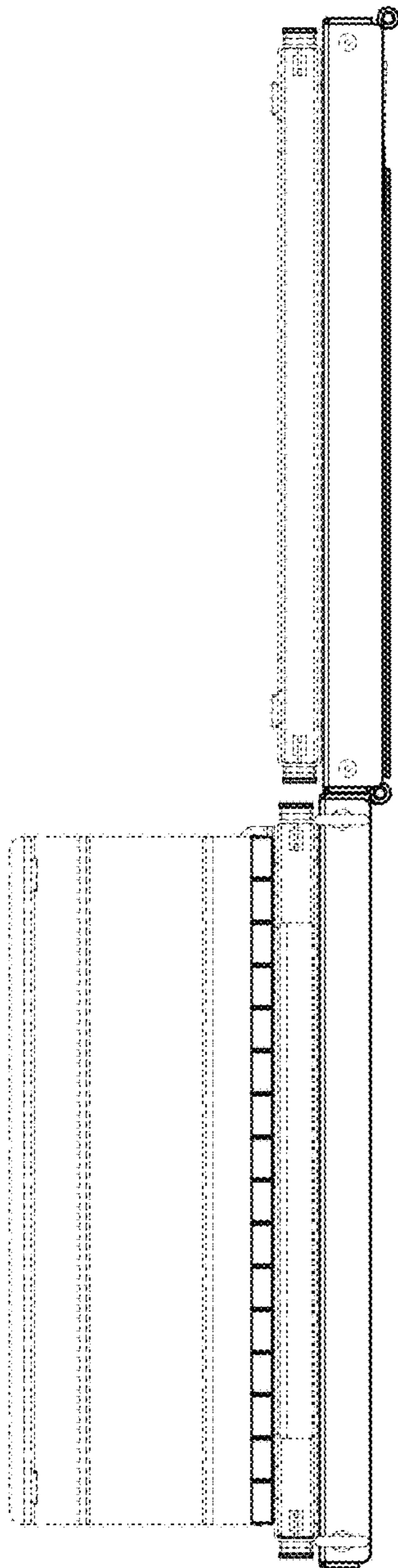

FIG. 11

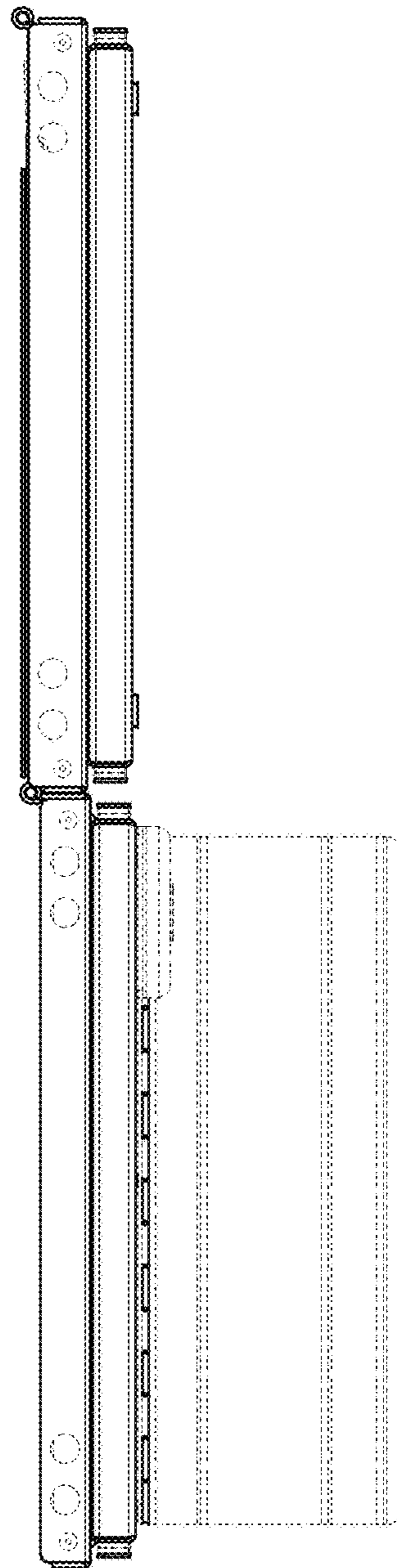

FIG. 12

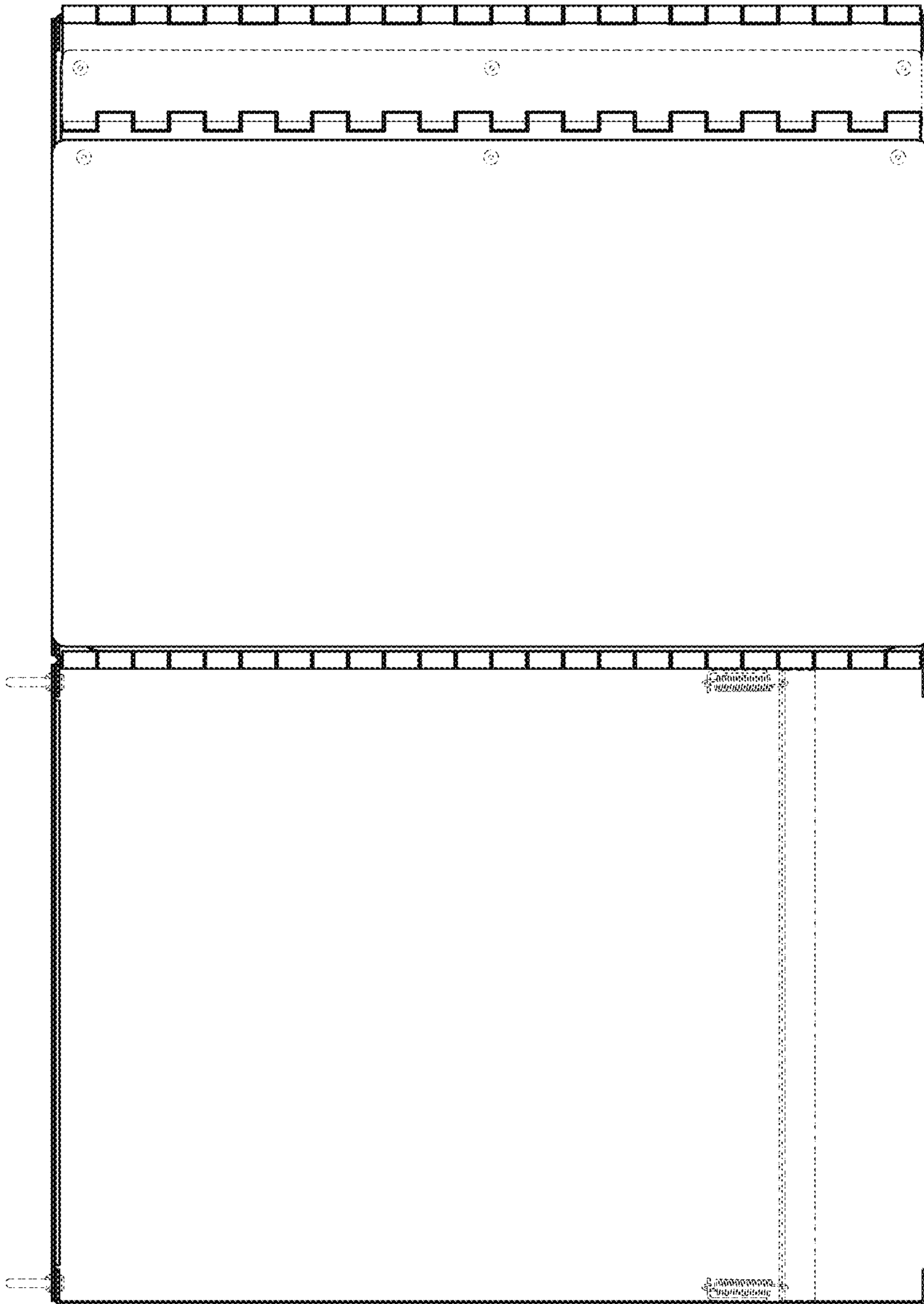

FIG. 13

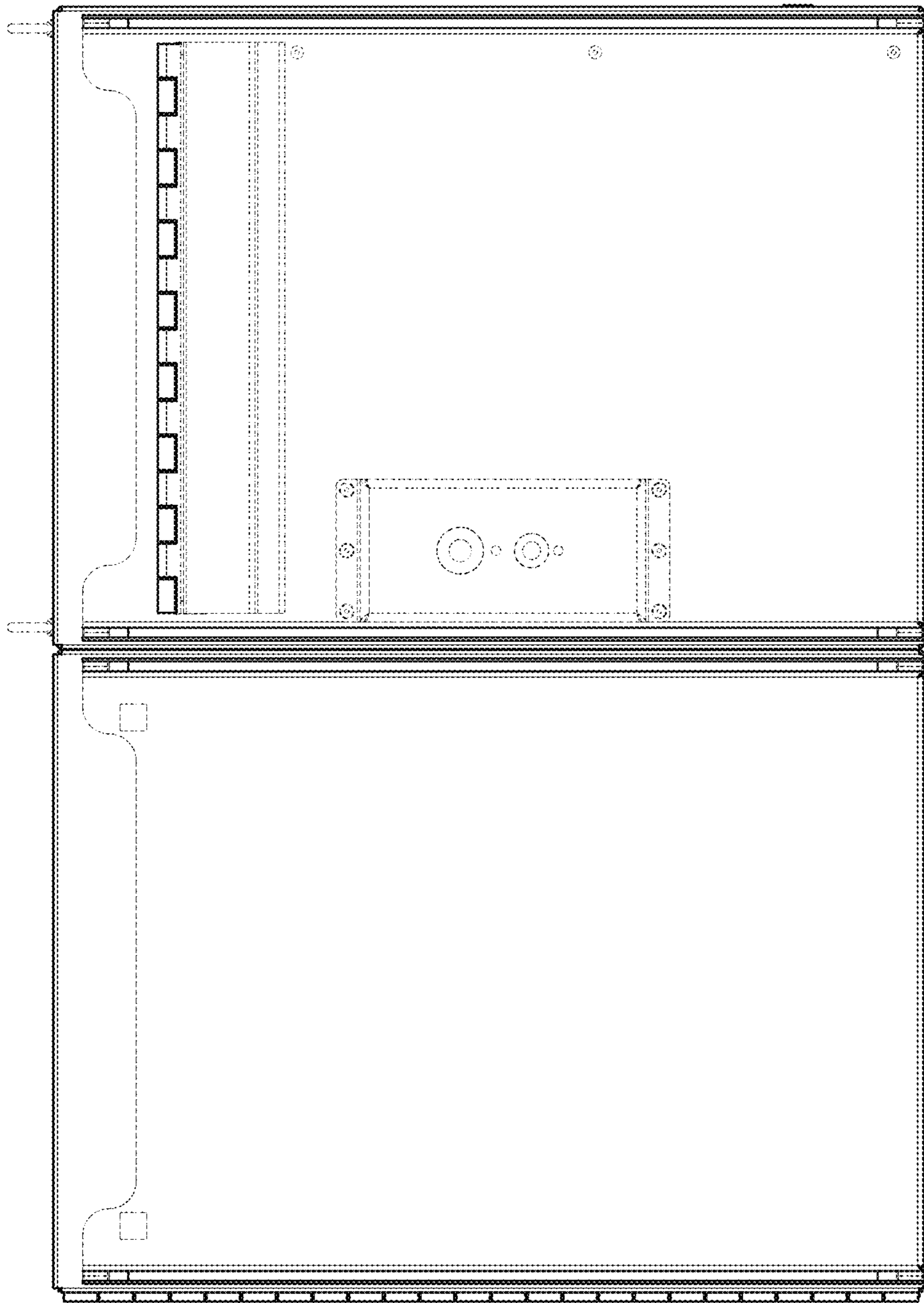

FIG. 14

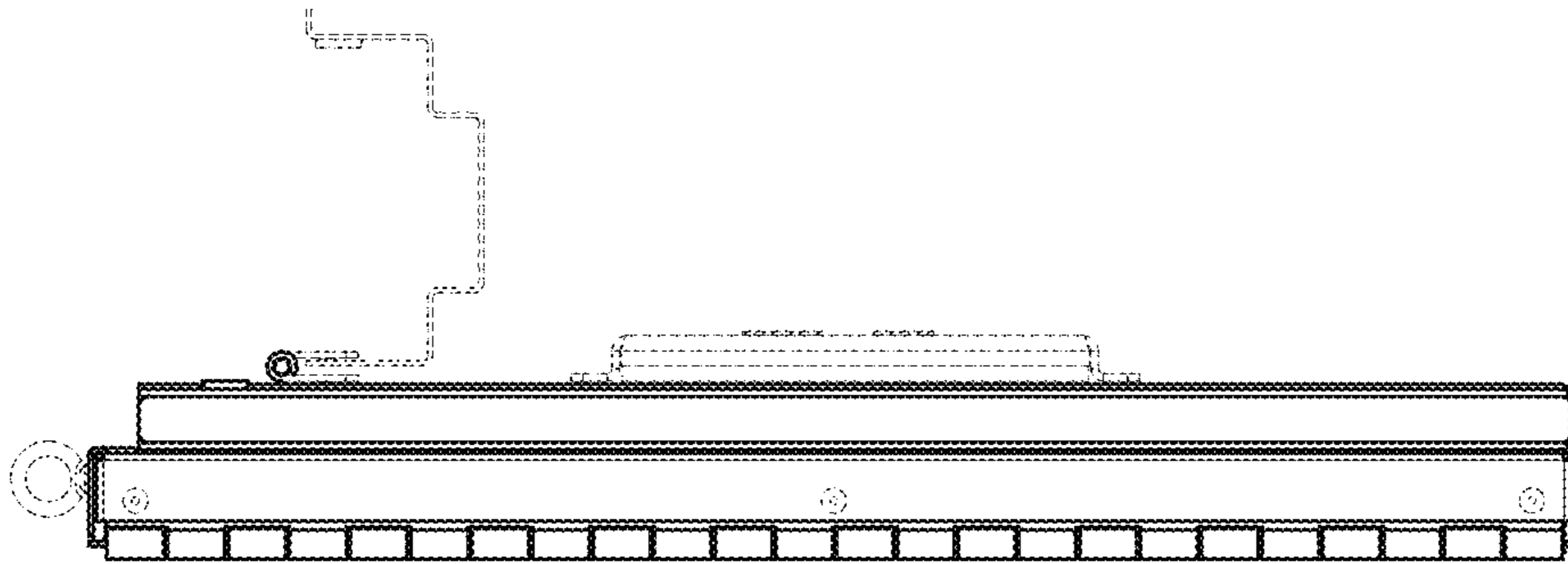

FIG. 16

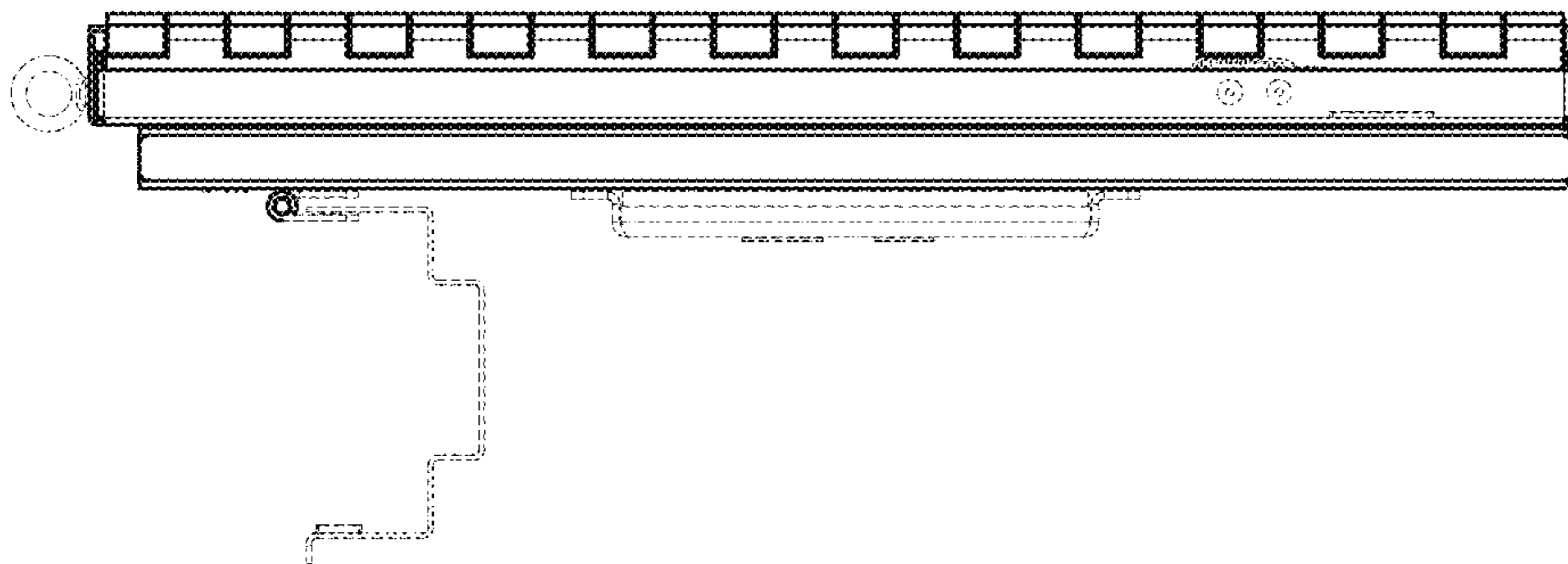

FIG. 15

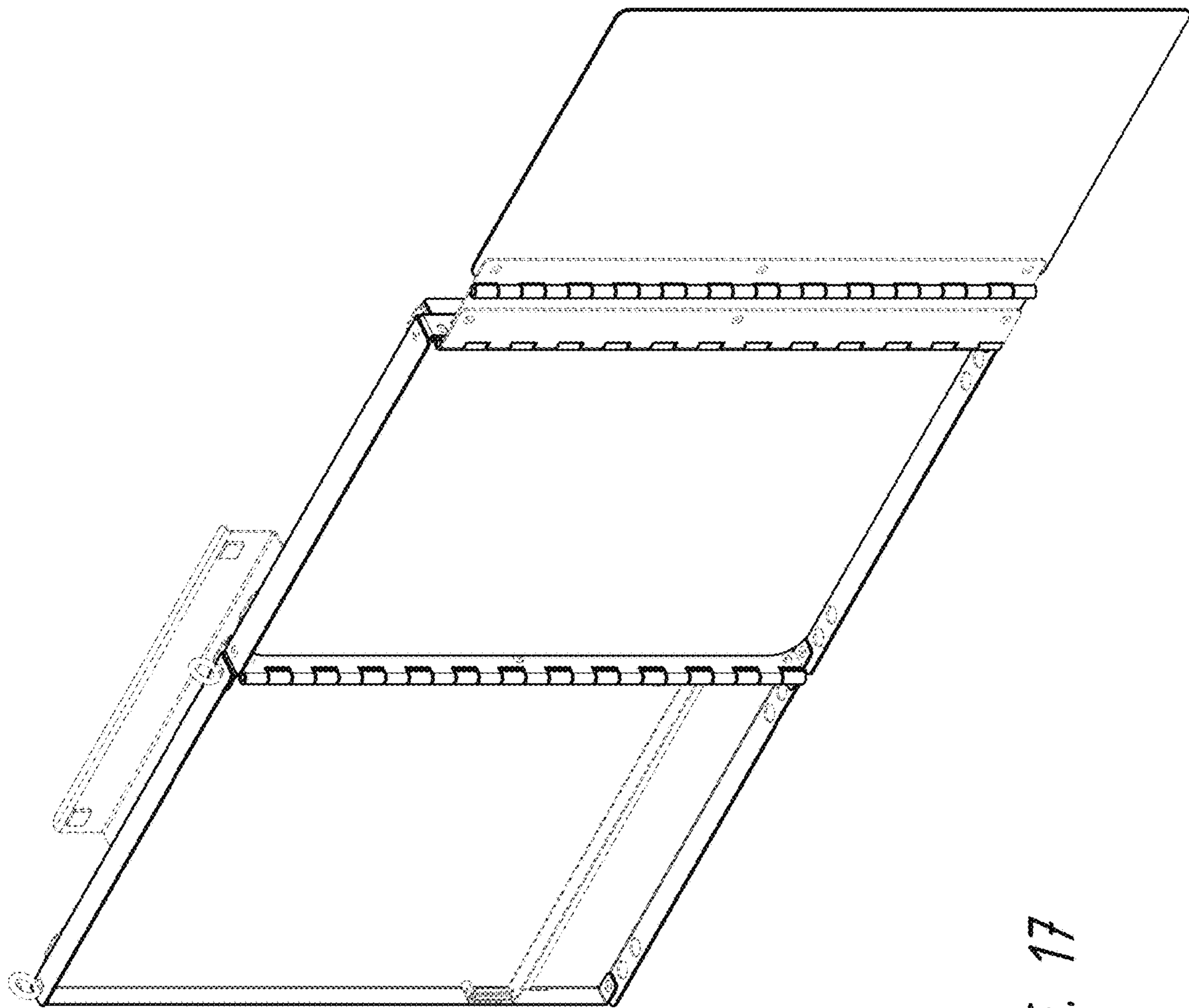
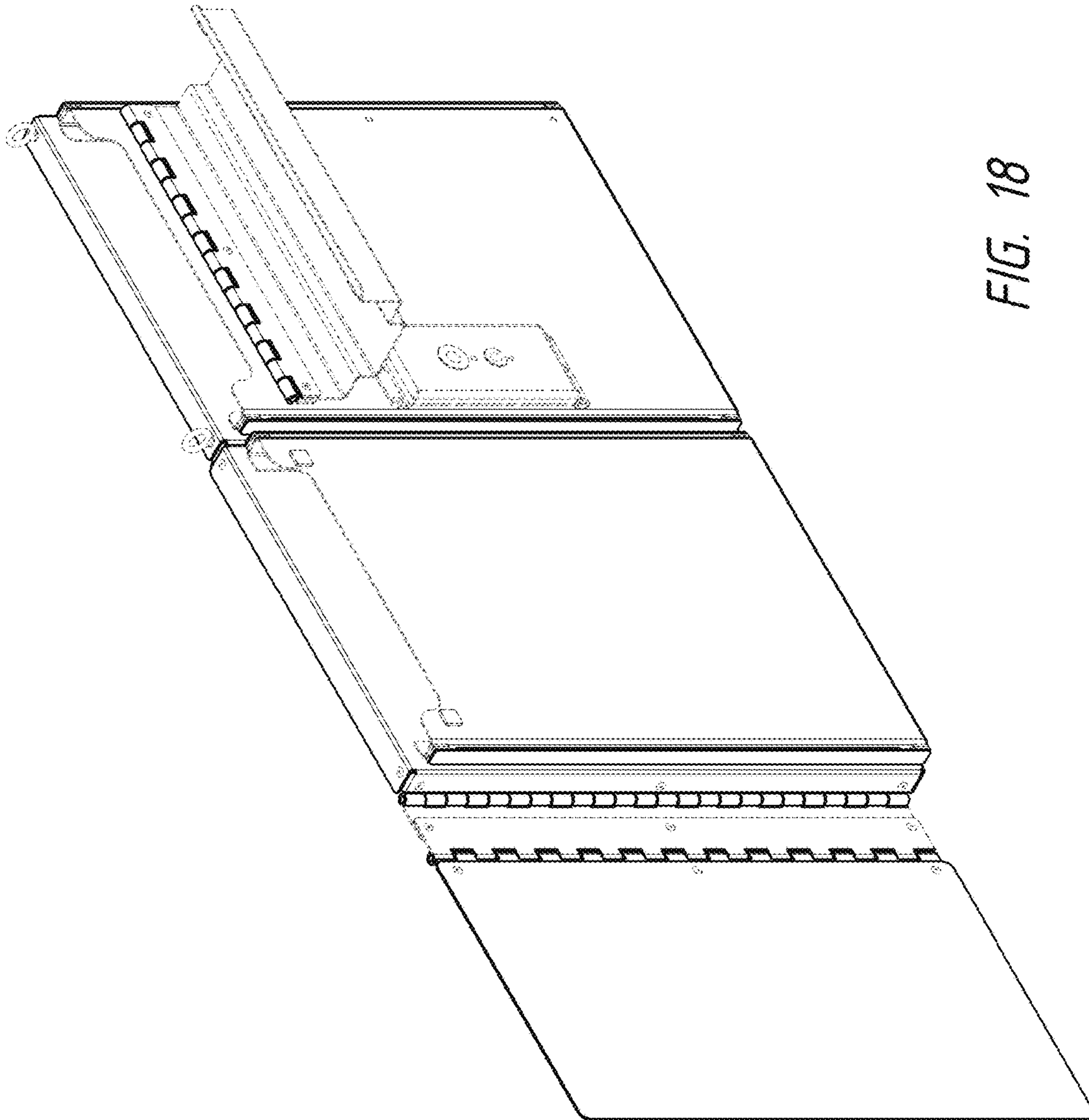

FIG. 17



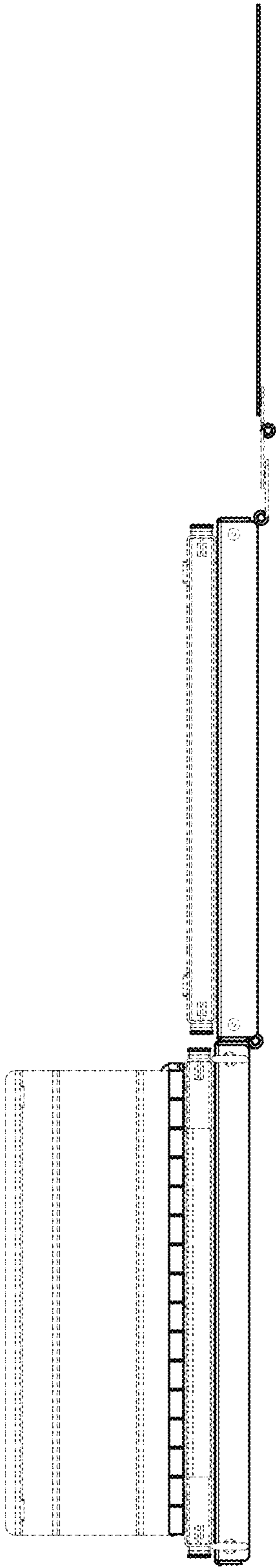

FIG. 19

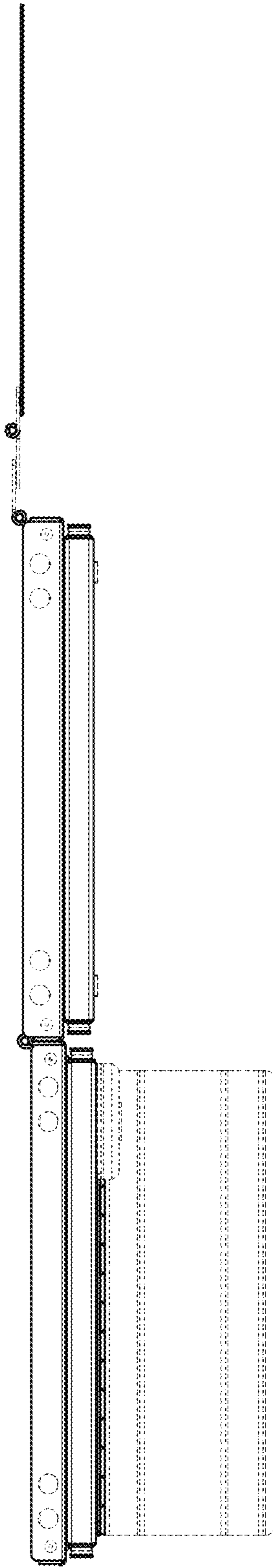

FIG. 20

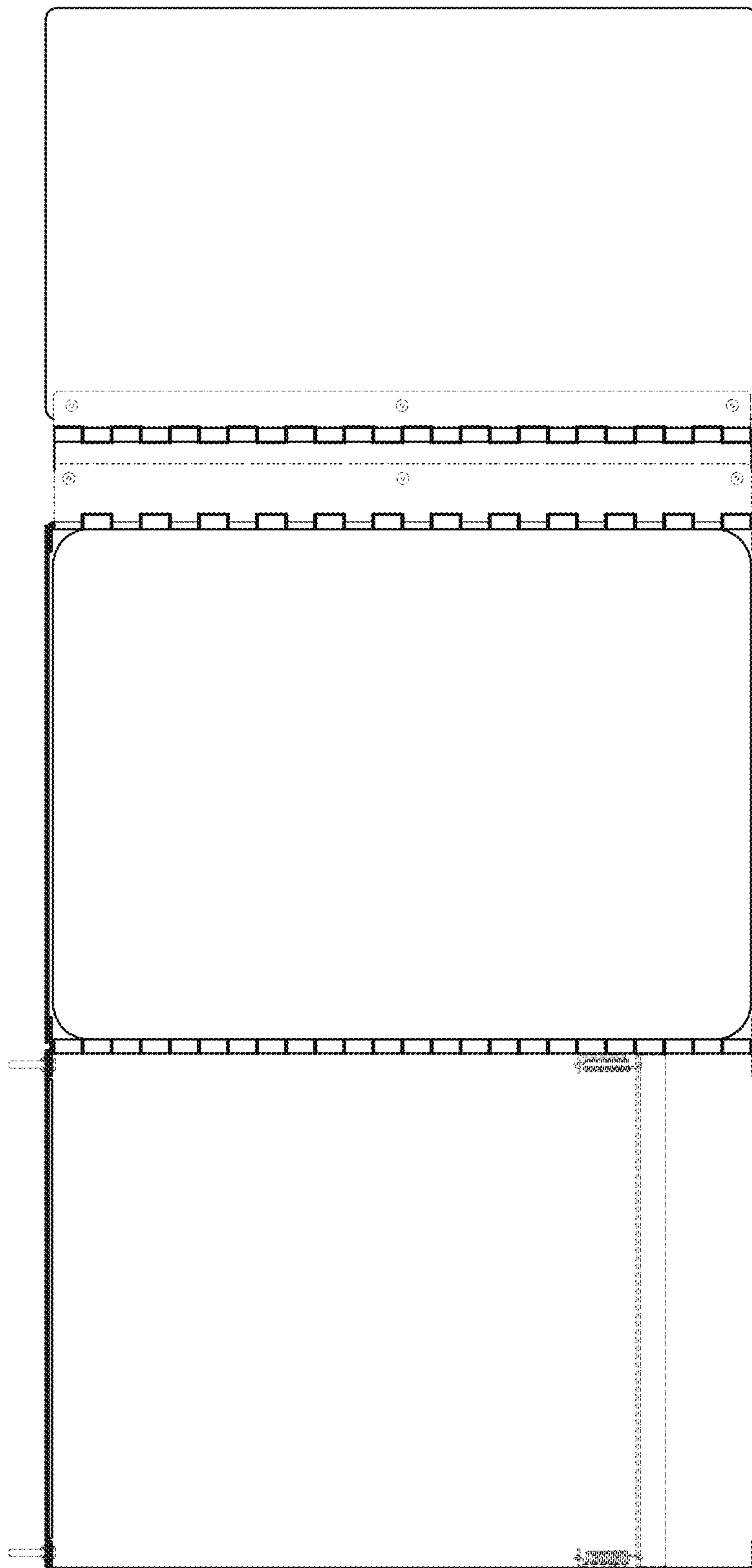

FIG. 21

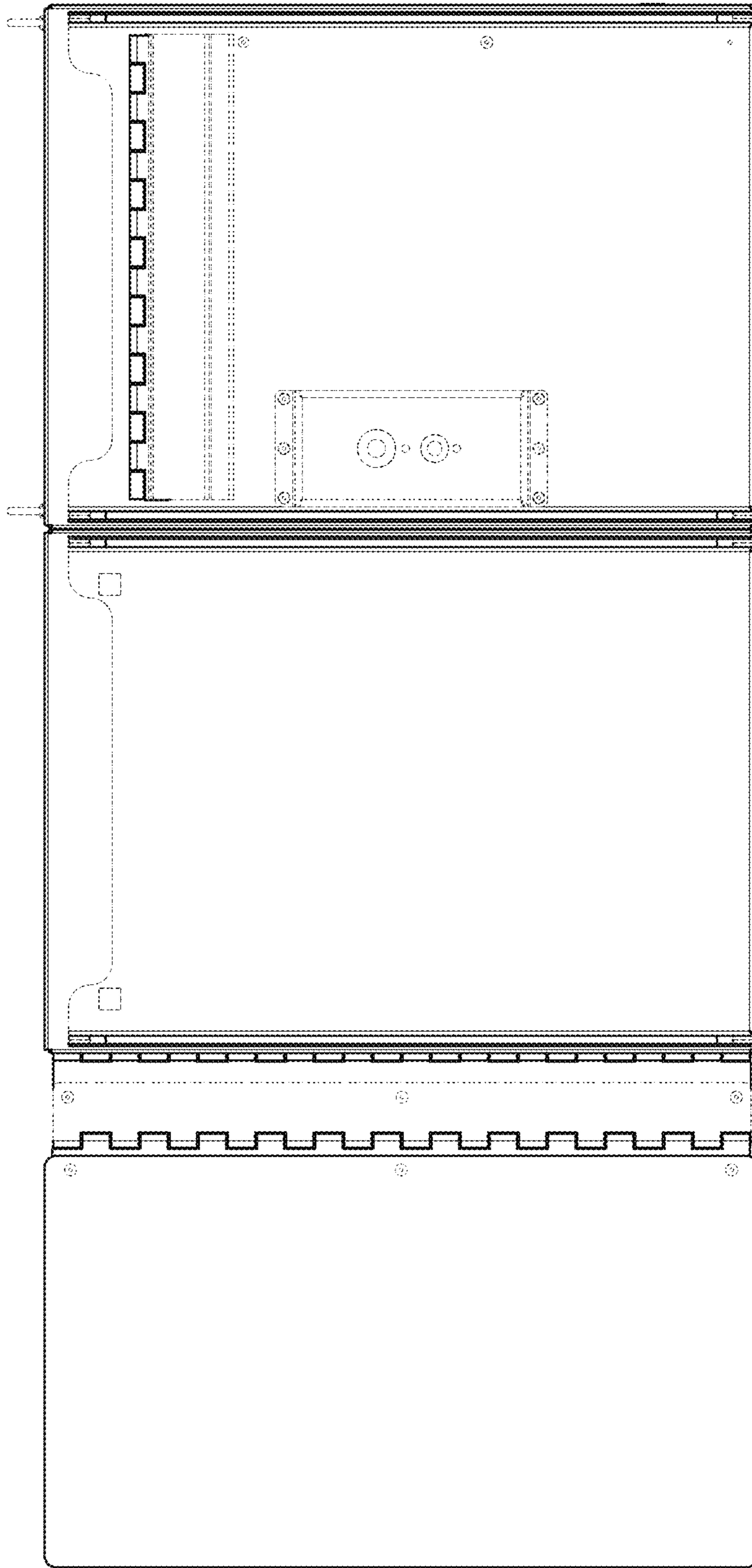

FIG. 22

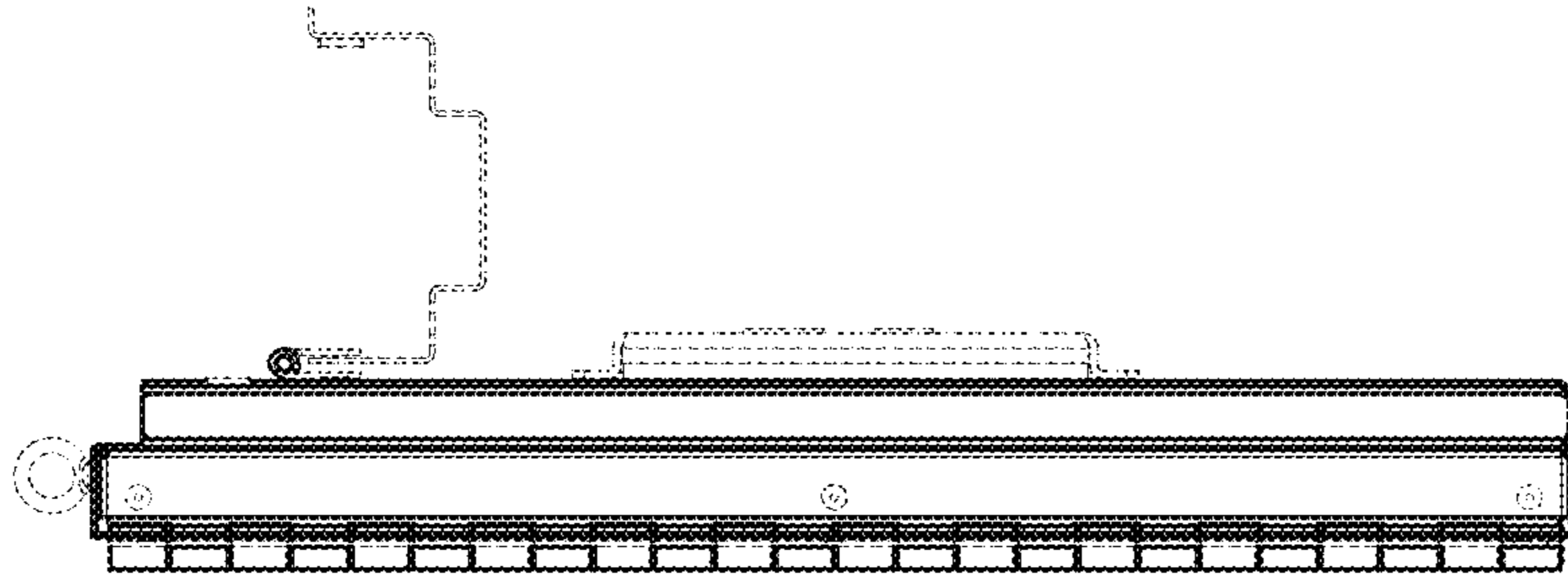

FIG. 24

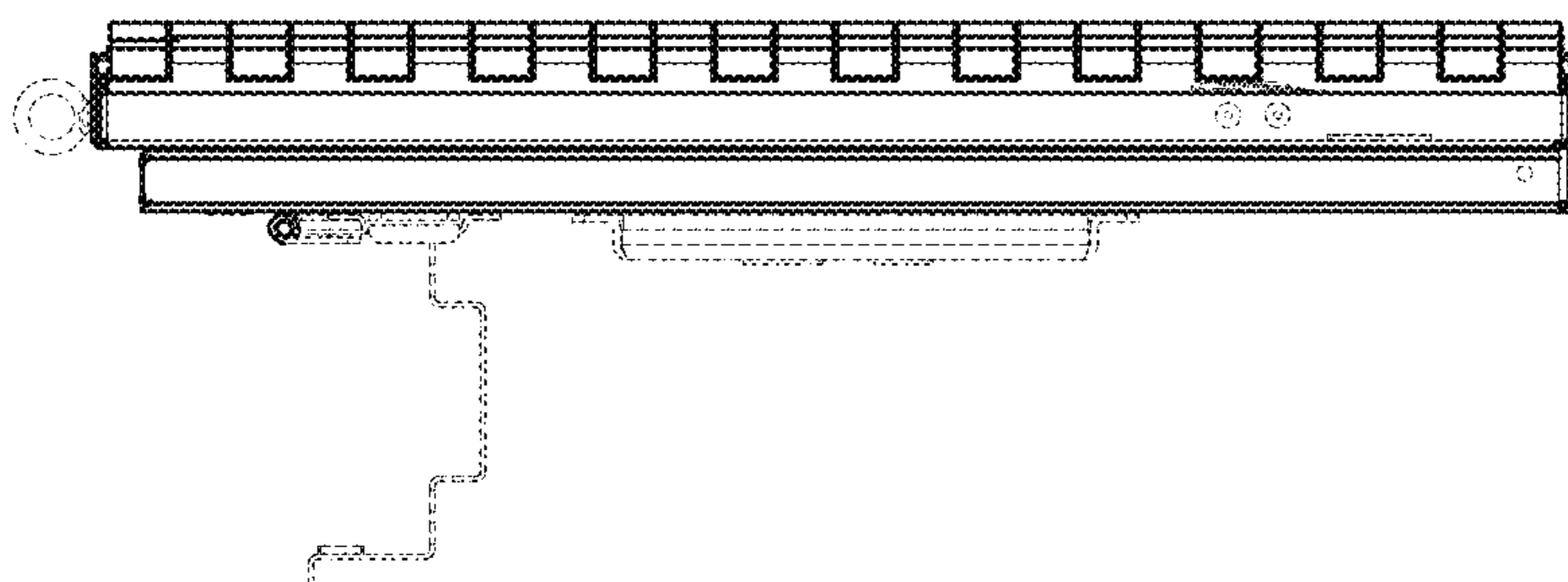

FIG. 23

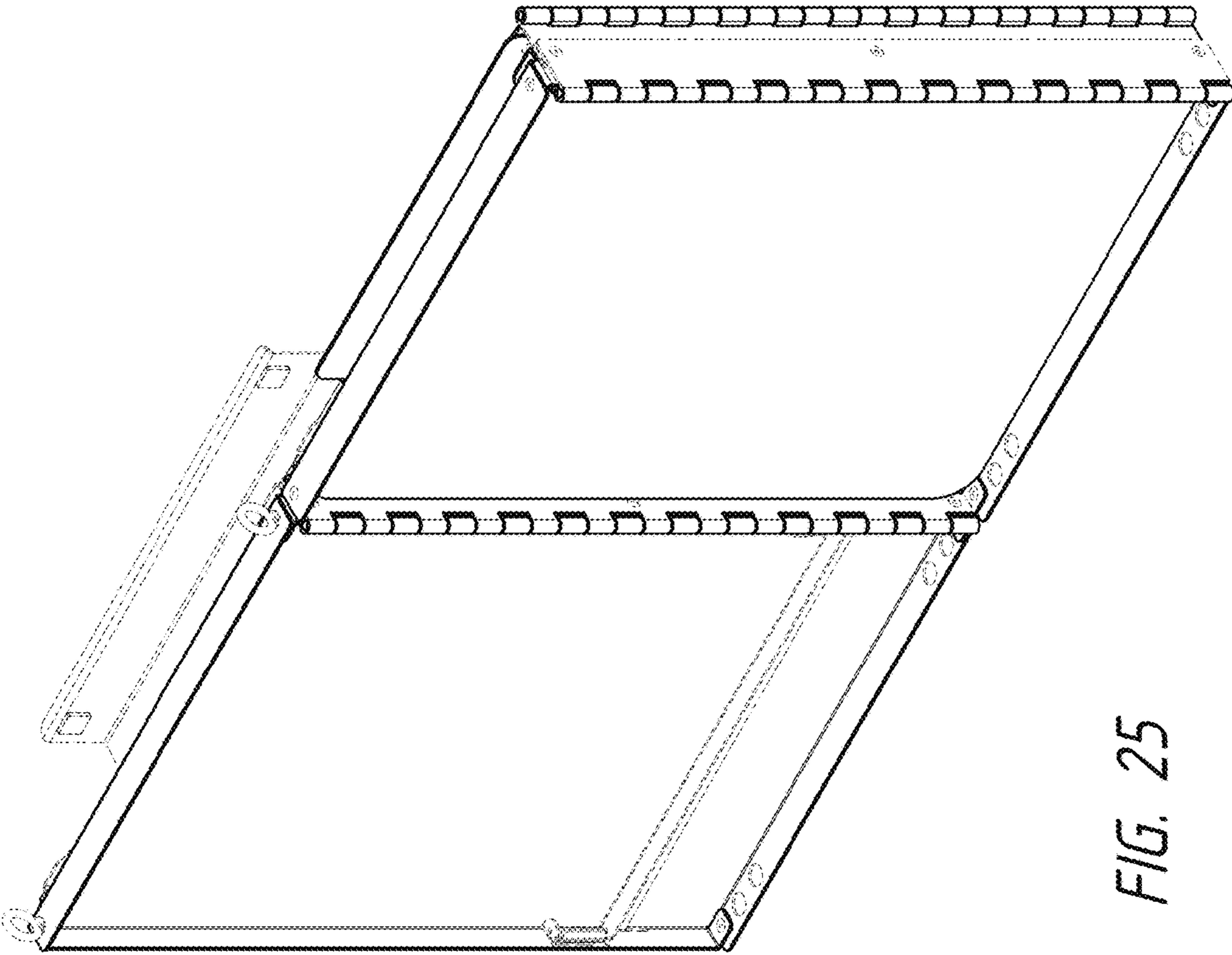
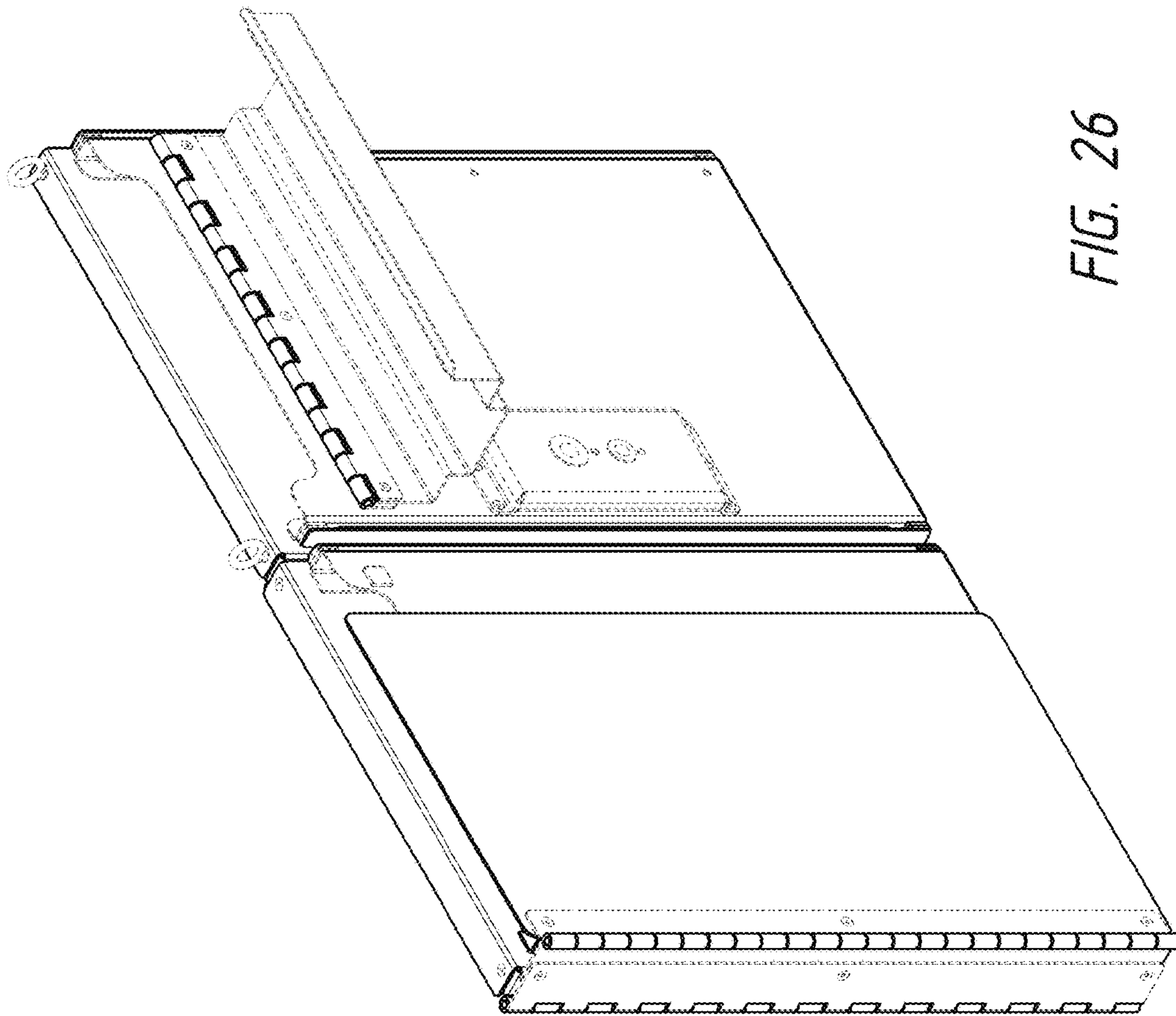

FIG. 25



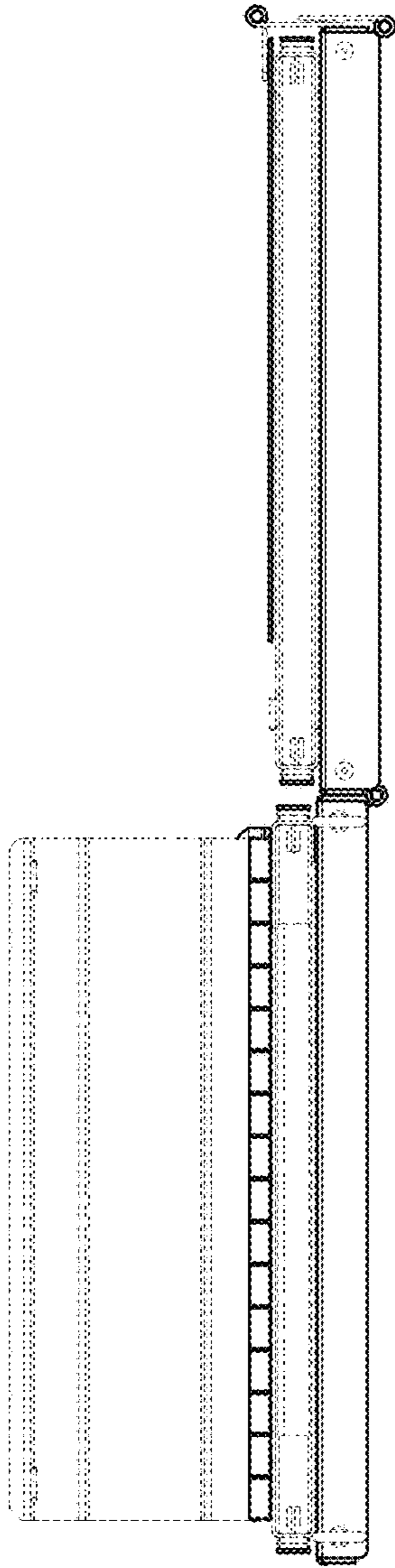

FIG. 27

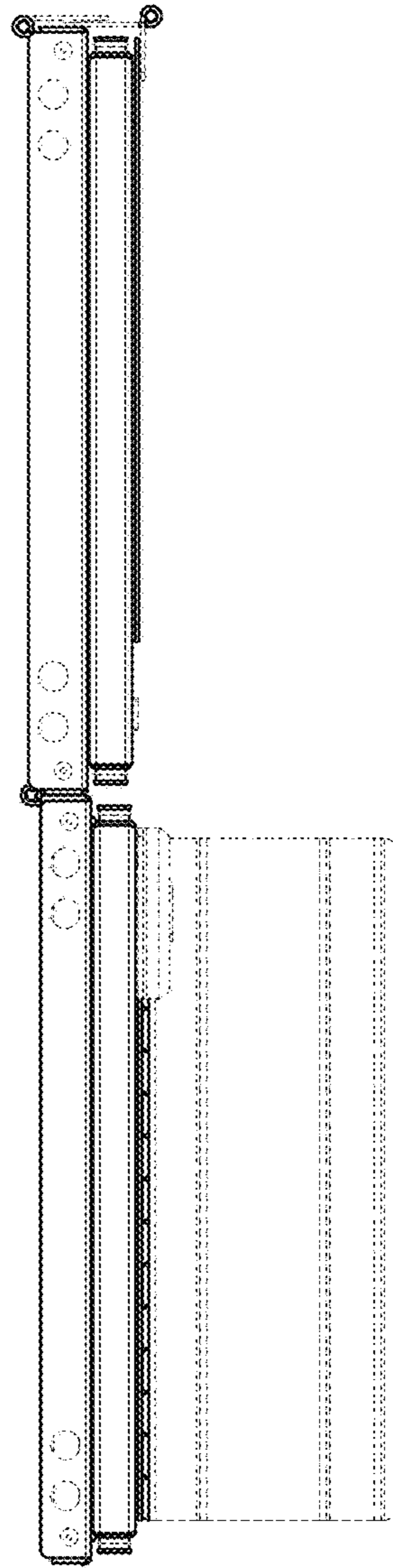

FIG. 28

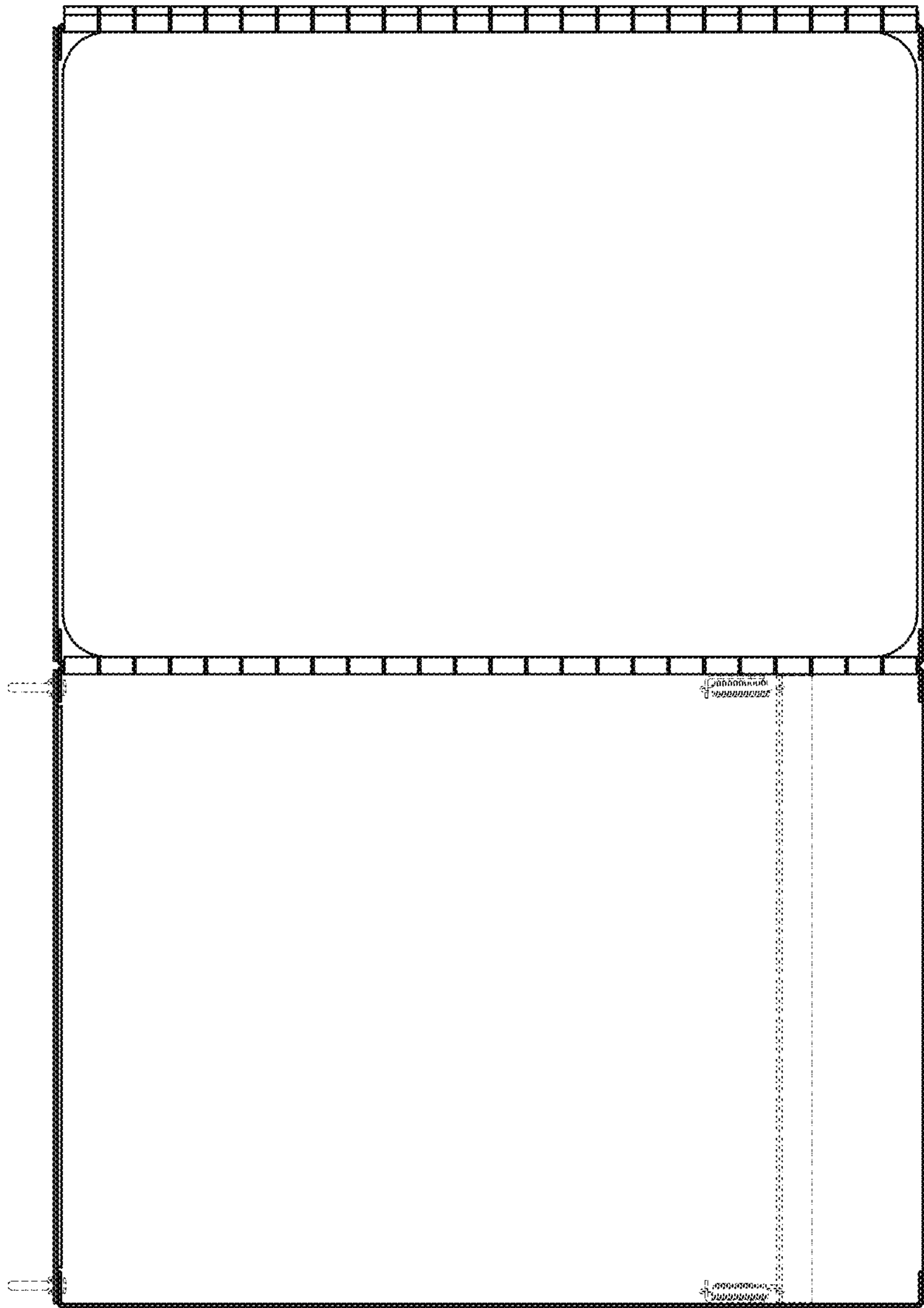

FIG. 29

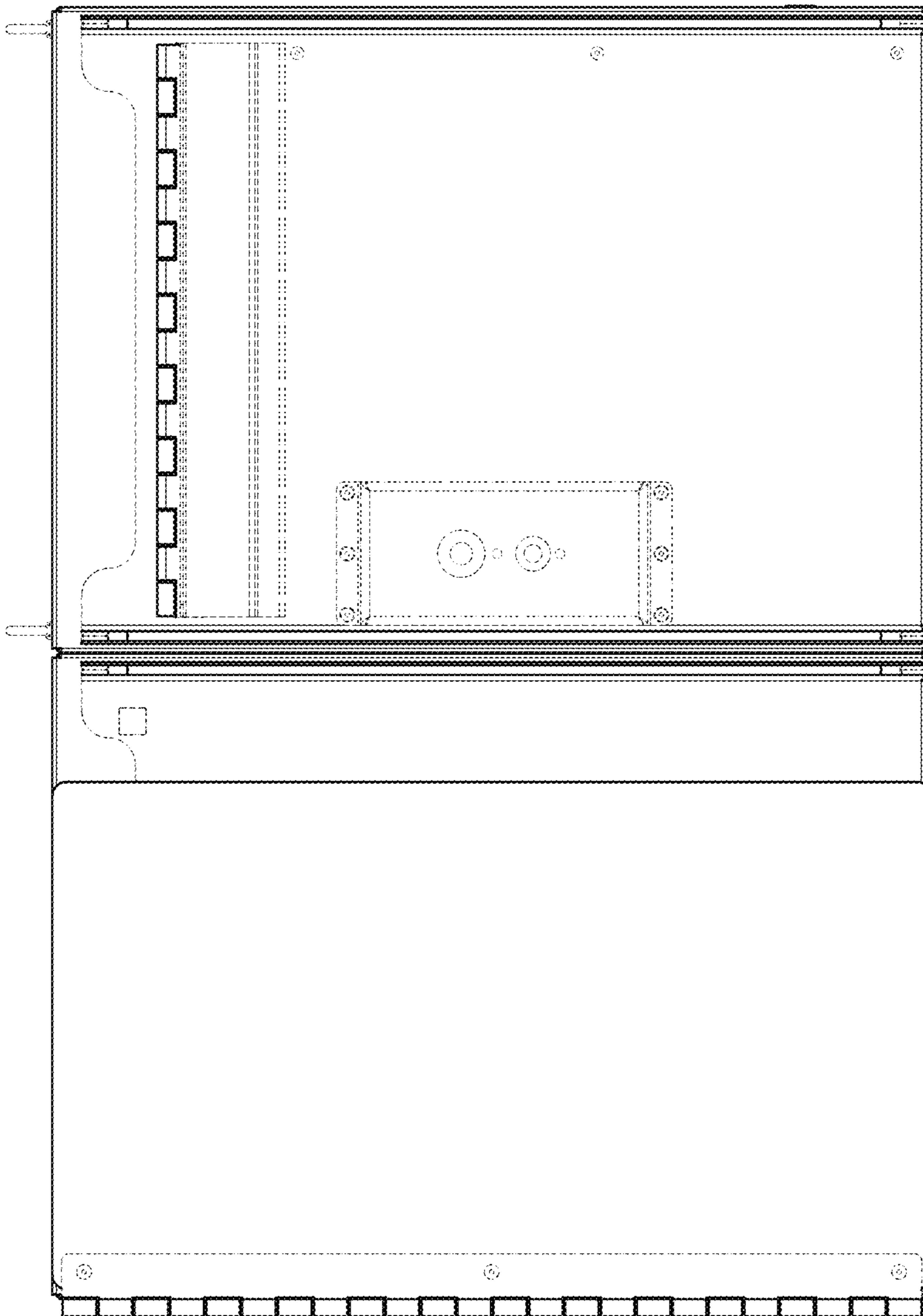

FIG. 30

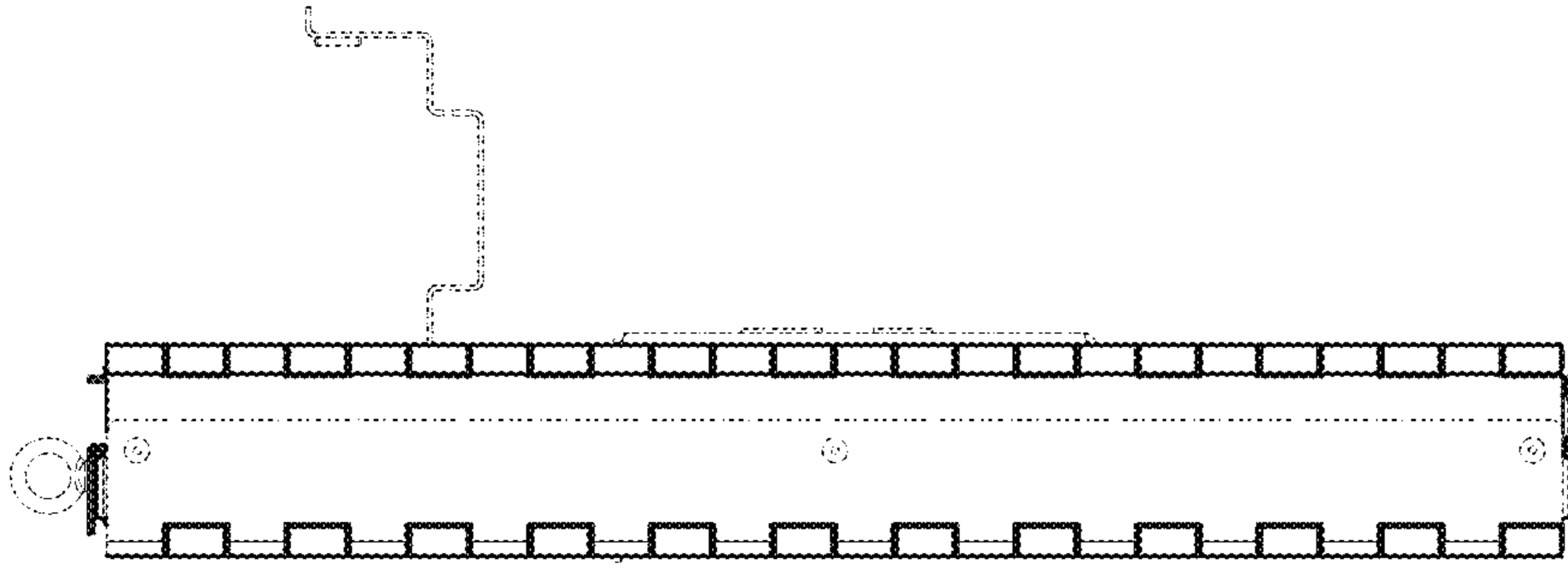

FIG. 32

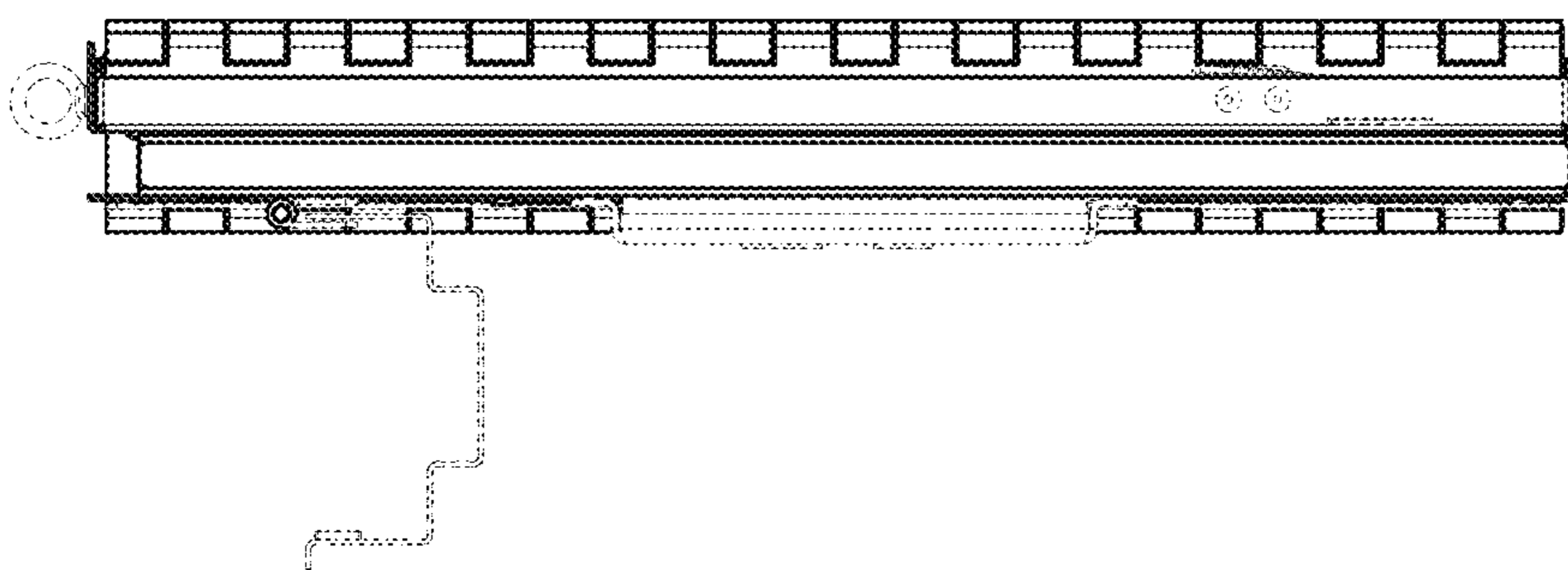

FIG. 31