



US00D804427S

(12) **United States Design Patent**
Baldwin et al.

(10) **Patent No.:** **US D804,427 S**

(45) **Date of Patent:** **** Dec. 5, 2017**

(54) **CABLE RAIL SYSTEM**

(71) Applicants: **Jeffrey Baldwin**, Desert Hills, AZ
(US); **John Klein**, Gilbert, AZ (US);
Ryan Liebengood, Gilbert, AZ (US)

(72) Inventors: **Jeffrey Baldwin**, Desert Hills, AZ
(US); **John Klein**, Gilbert, AZ (US);
Ryan Liebengood, Gilbert, AZ (US)

(**) Term: **15 Years**

(21) Appl. No.: **29/561,061**

(22) Filed: **Apr. 13, 2016**

Related U.S. Application Data

(63) Continuation of application No. 29/488,417, filed on
Apr. 18, 2014, now Pat. No. Des. 756,936.

(51) **LOC (10) Cl.** **13-03**

(52) **U.S. Cl.**
USPC **D13/155**

(58) **Field of Classification Search**

USPC D13/155, 129, 131, 132, 133, 153, 154,
D13/156, 157, 184, 199; D8/354, 356,
D8/366, 380, 396; 138/106, 107, 112,
138/113, 116, 117, 155-158, 166-169,
138/174; 174/5 R, 38, 68.1, 68.2, 68.3,
174/101, 135, 136, 481, 504
CPC H02G 3/08; H02G 3/0608; H02G 3/0418;
H02G 3/0425; H02G 3/0431; H02G
3/0437; H02G 5/08; H01R 25/14; H01R
25/142; H01R 13/453; E04F 19/04; E04F
19/0463; E04F 19/0468; E04F 2019/044;
E04F 2019/0427; E04F 2019/0431

See application file for complete search history.

(56) **References Cited**

U.S. PATENT DOCUMENTS

3,786,171 A * 1/1974 Shira H02G 3/0425
138/108
4,530,865 A * 7/1985 Sprenger E04F 19/04
138/111

D371,343 S * 7/1996 Loftus D13/155
6,191,363 B1 * 2/2001 Samuels H02G 3/0425
174/68.3
6,323,421 B1 * 11/2001 Pawson H02G 3/0418
174/503
6,513,289 B1 * 2/2003 Decore H02G 3/0406
16/225
D486,130 S 2/2004 Thibault
D498,211 S 11/2004 Thibault
D499,699 S 12/2004 Thibault
D503,968 S 4/2005 Ruddick
D503,969 S 4/2005 Ruddick
D504,938 S 5/2005 Ruddick
6,972,367 B2 * 12/2005 Federspiel H02G 3/0418
174/481

(Continued)

Primary Examiner — Derrick Holland

(74) *Attorney, Agent, or Firm* — Ryan Liebengood

(57) **CLAIM**

We claim the ornamental design for a cable rail system, as
shown and described.

DESCRIPTION

FIG. 1 is a perspective view of a cable rail system showing
our design;

FIG. 2 is an end view thereof;

FIG. 3 is a bottom plan view thereof, with the top plan view
being identical;

FIG. 4 is rear elevational view thereof; and,

FIG. 5 is a front elevational view thereof.

The broken lines shown in the Figures are included for the
purpose of illustrating environmental features and form no
part of the claimed design.

The claim is shown with a symbolic break in its length. The
appearance of any portion of the article between the break
lines forms no part of the claimed design.

1 Claim, 4 Drawing Sheets

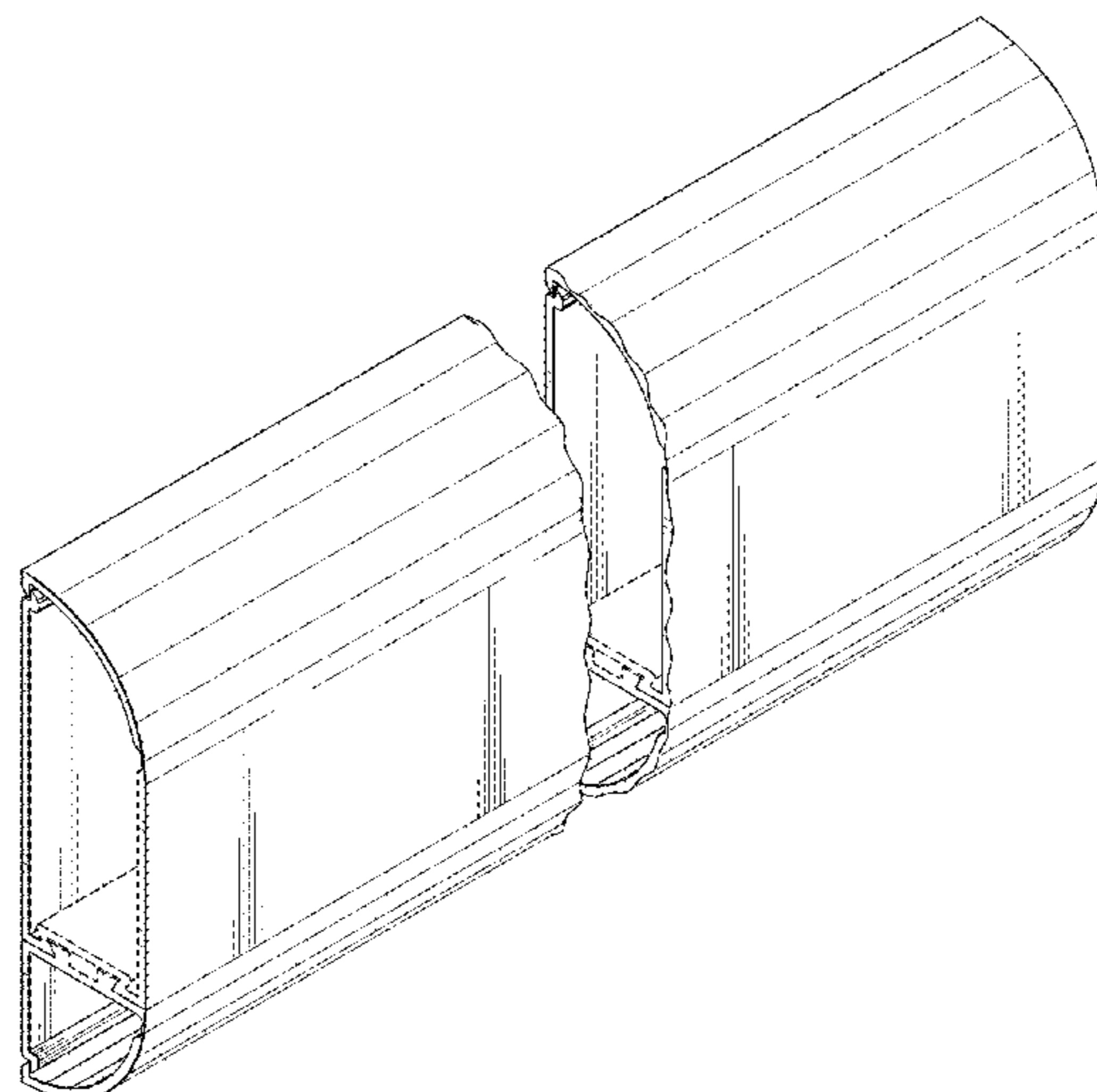

(56)

References Cited

U.S. PATENT DOCUMENTS

D539,752	S	4/2007	Ruddick	
D539,755	S	4/2007	Makwinski	
D541,143	S	4/2007	Ruddick	
7,612,300	B2 *	11/2009	Owens	G02B 6/4459 174/480
7,696,434	B2	4/2010	Ruddick	
7,741,568	B2	6/2010	Makwinski	
D669,035	S	10/2012	Ruddick	
D671,502	S	11/2012	Ruddick	
D683,318	S	5/2013	Ruddick	
8,729,408	B2 *	5/2014	Pawlak	E04F 19/04 174/504
2005/0221646	A1	10/2005	Evilsizer	
2007/0218720	A1	9/2007	Jong	

* cited by examiner

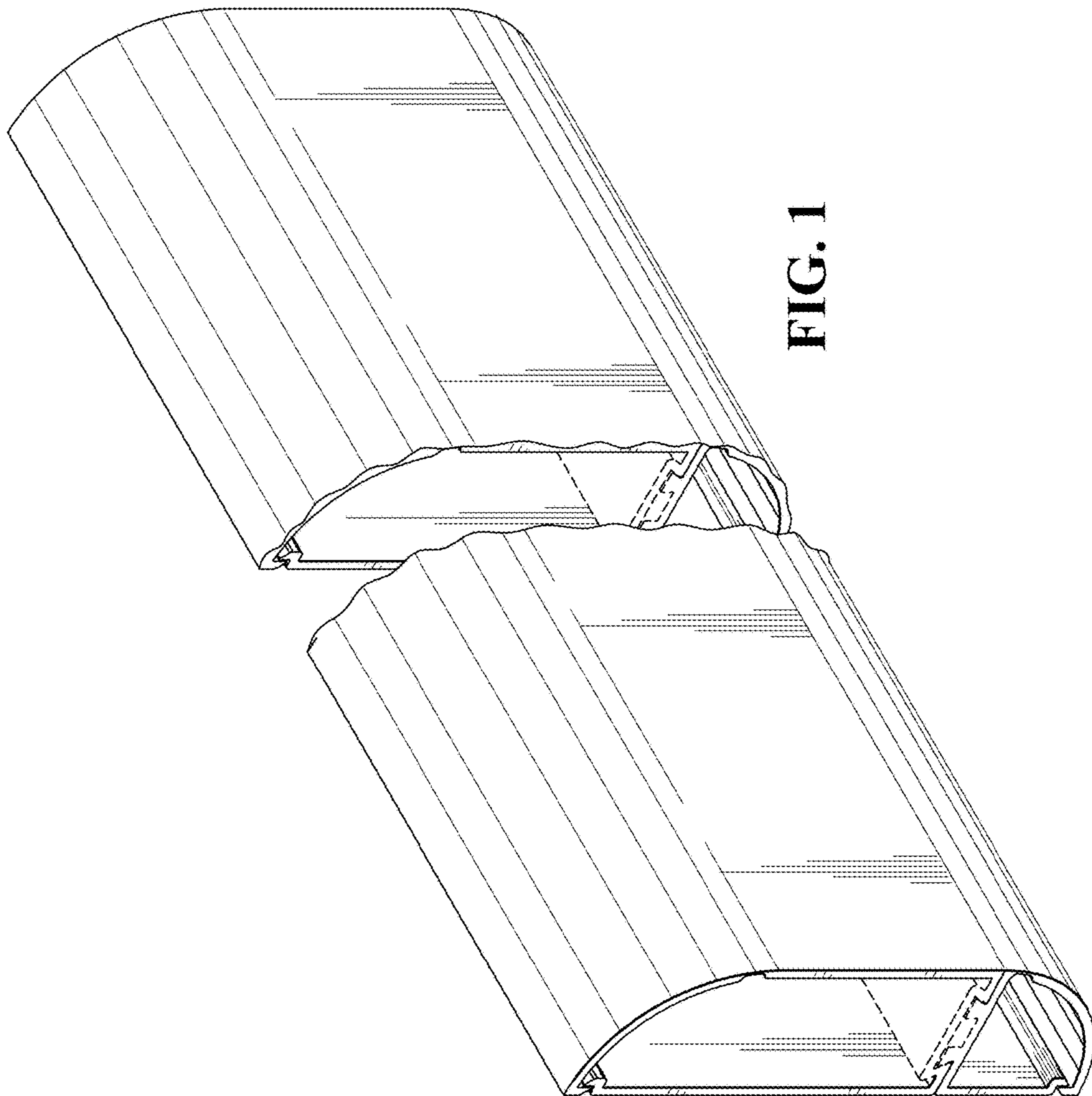

FIG. 1

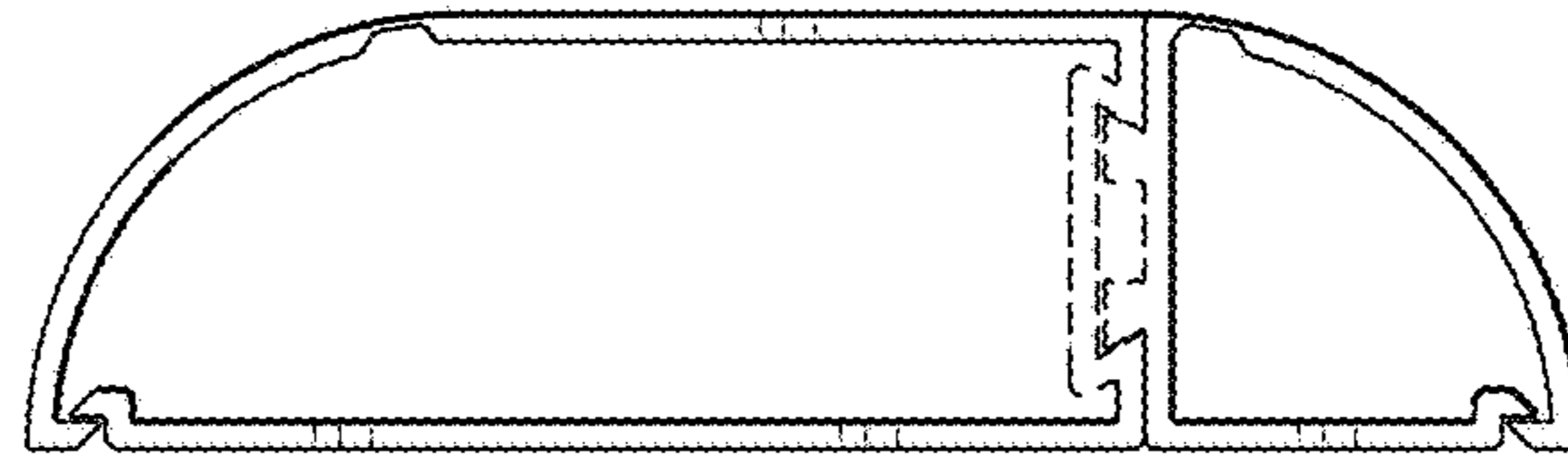

FIG. 2

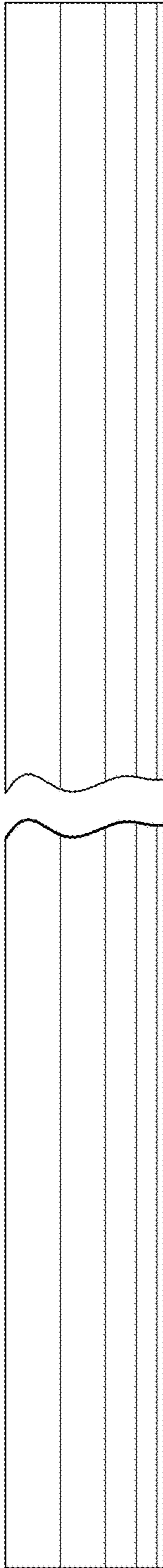

FIG. 3

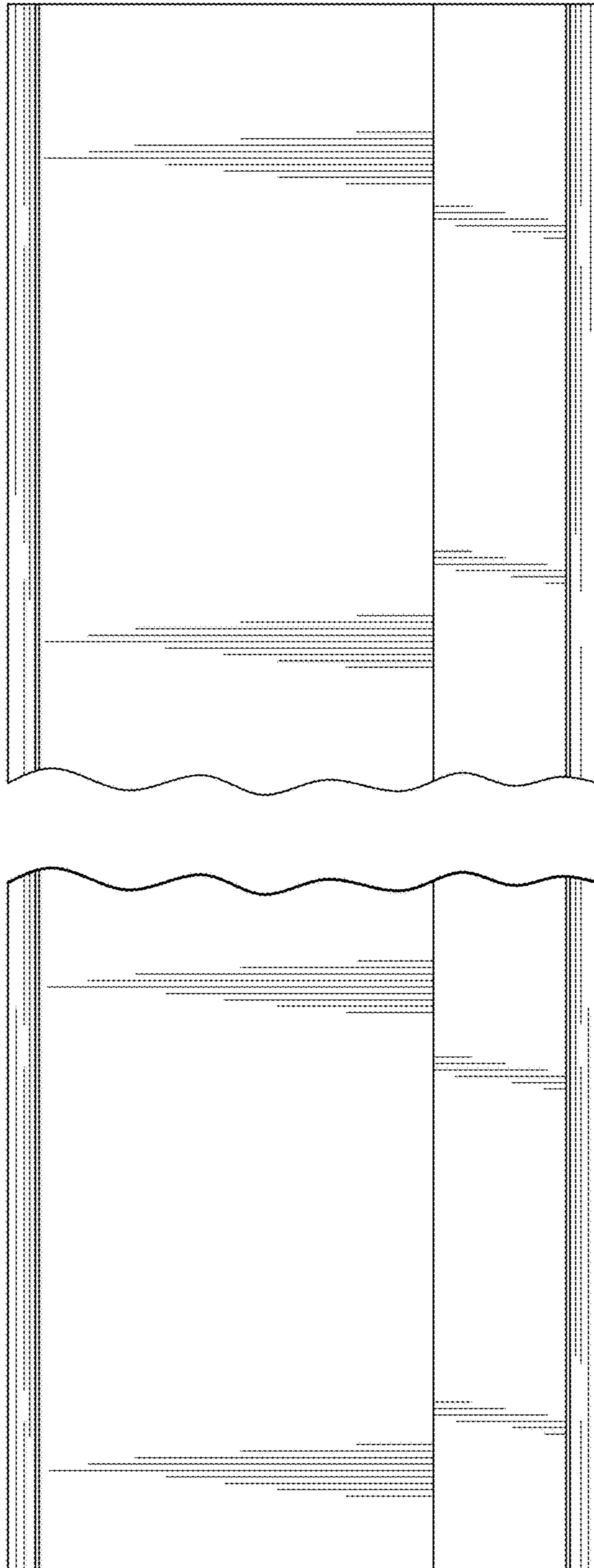

FIG. 4

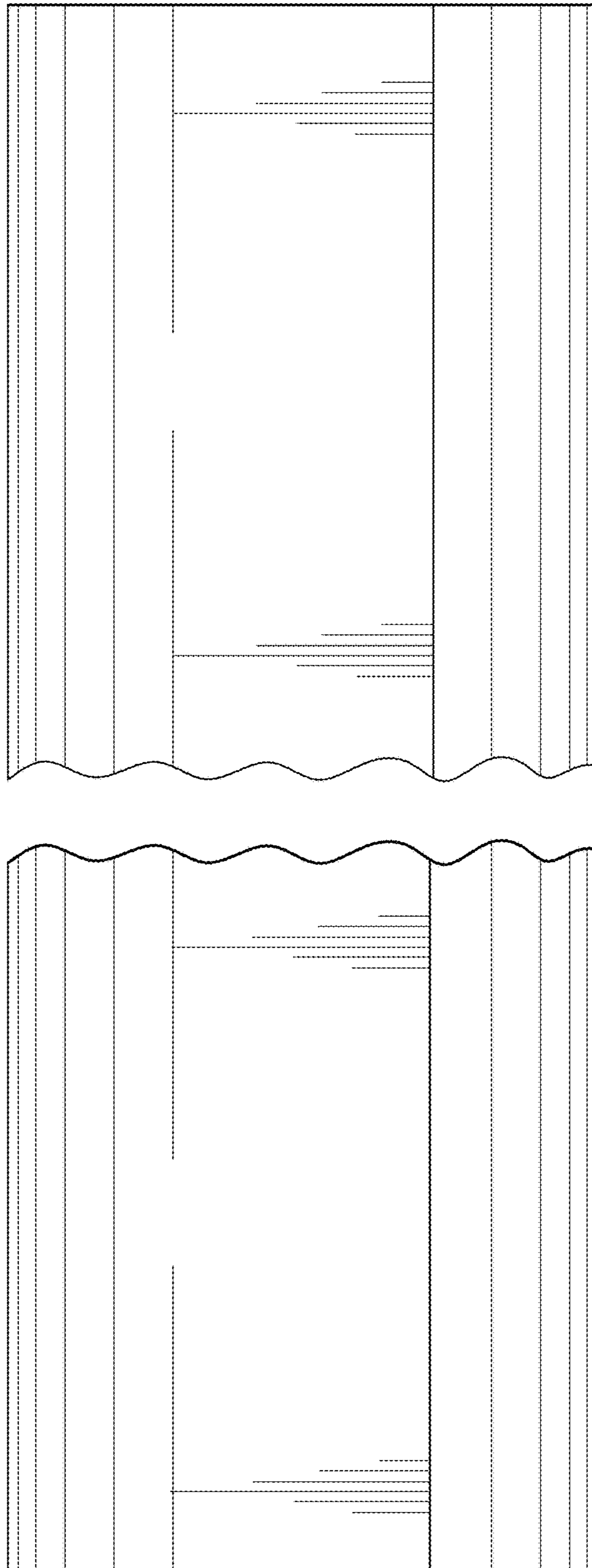

FIG. 5