



US00D804359S

(12) **United States Design Patent**
Ishii

(10) **Patent No.:** **US D804,359 S**
(45) **Date of Patent:** **** Dec. 5, 2017**

(54) **AUTOMOBILE AND/OR REPLICA THEREOF**

D752,481 S * 3/2016 Frascella D12/91
D760,137 S * 6/2016 Galante D12/196
D770,330 S 11/2016 Watanabe

(71) Applicant: **HONDA MOTOR CO., LTD.**, Tokyo
(JP)

(72) Inventor: **Yuki Ishii**, Wako (JP)

(73) Assignee: **HONDA MOTOR CO., LTD.**, Tokyo
(JP)

(**) Term: **15 Years**

(21) Appl. No.: **29/579,599**

(22) Filed: **Sep. 30, 2016**

(30) **Foreign Application Priority Data**

Apr. 1, 2016 (JP) 2016-007289

(51) **LOC (10) Cl.** **12-08**

(52) **U.S. Cl.**
USPC **D12/91**

(58) **Field of Classification Search**
USPC D12/90-92, 164, 169, 196;
296/181.1-181.5; D21/548, 560
CPC B60Y 2306/01; B60K 11/085
See application file for complete search history.

(56) **References Cited**

U.S. PATENT DOCUMENTS

D466,051 S * 11/2002 Stoddard D12/91
D506,955 S * 7/2005 Allen D12/163
D532,717 S * 11/2006 Dolan D12/91
D542,181 S * 5/2007 Dolan D12/91
D586,697 S * 2/2009 Nagode D12/91
D713,308 S * 9/2014 Galante D12/196
D725,550 S * 3/2015 Wolff D12/91
D727,210 S * 4/2015 Grake D12/91
D733,004 S * 6/2015 Huang D12/91
D734,230 S * 7/2015 Wheel D12/196
D751,005 S * 3/2016 Galante D12/164

FOREIGN PATENT DOCUMENTS

JP D1526532 S 6/2015
KR 30-0595214 S 4/2011

OTHER PUBLICATIONS

Japanese magazine, "Car and Driver" (p. 73 of Issue No. 11 published on Nov. 1, 2013) showing "Honda Fit Hybrid S-Package". (1 page).

(Continued)

Primary Examiner — John Windmuller

Assistant Examiner — Melvin L Davis

(74) *Attorney, Agent, or Firm* — Westerman, Hattori, Daniels & Adrian, LLP

(57) **CLAIM**

The ornamental design for an automobile and/or replica thereof, as shown and described.

DESCRIPTION

FIG. 1 is a front view of an automobile and/or replica thereof;

FIG. 2 is a rear view thereof;

FIG. 3 is a plan view thereof;

FIG. 4 is a right side view thereof;

FIG. 5 is a left side view thereof;

FIG. 6 is a front perspective view thereof as seen from the right side; and,

FIG. 7 is a rear perspective view thereof as seen from the right side.

The broken lines form no part of the claimed design.

1 Claim, 6 Drawing Sheets

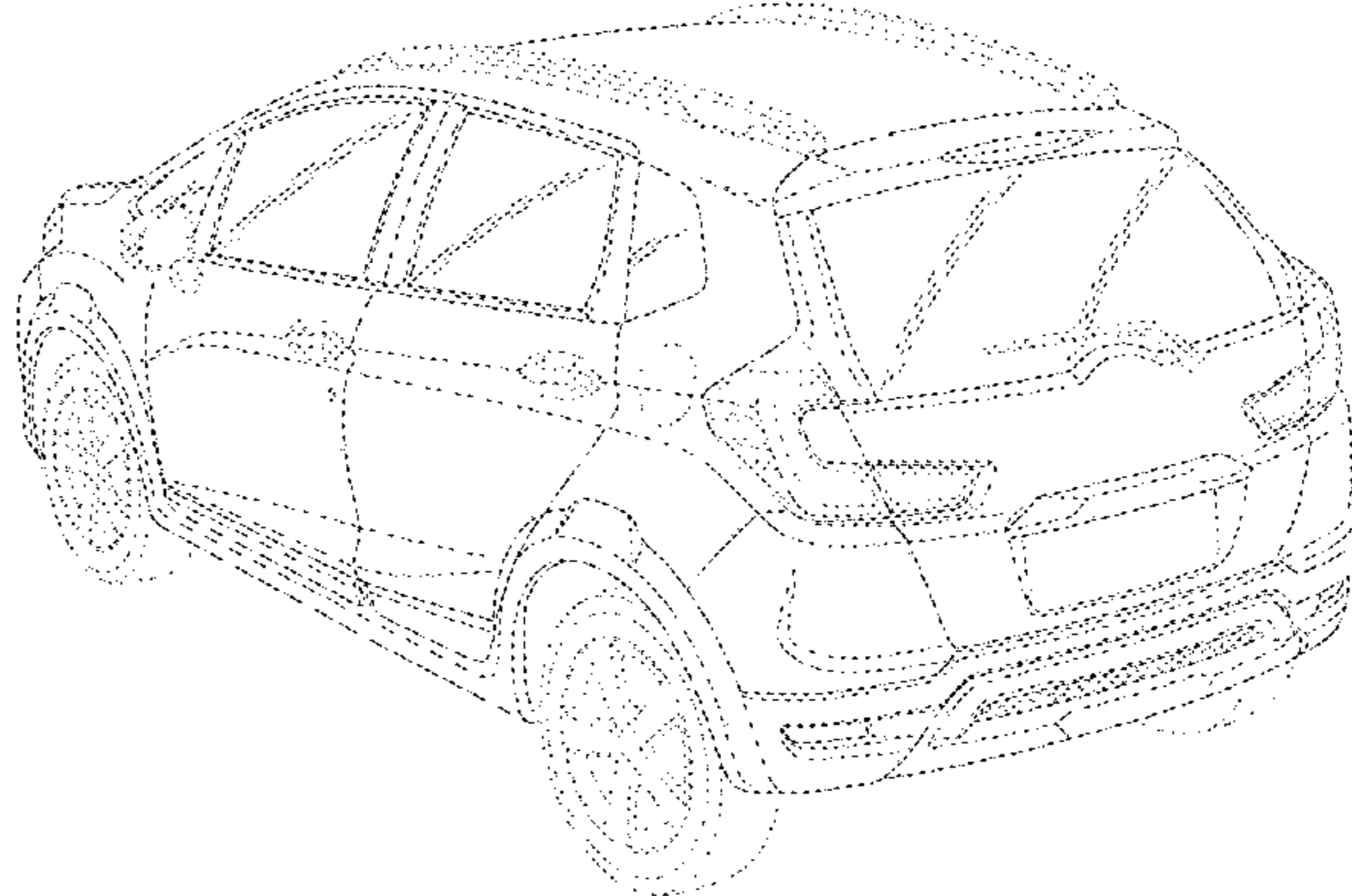
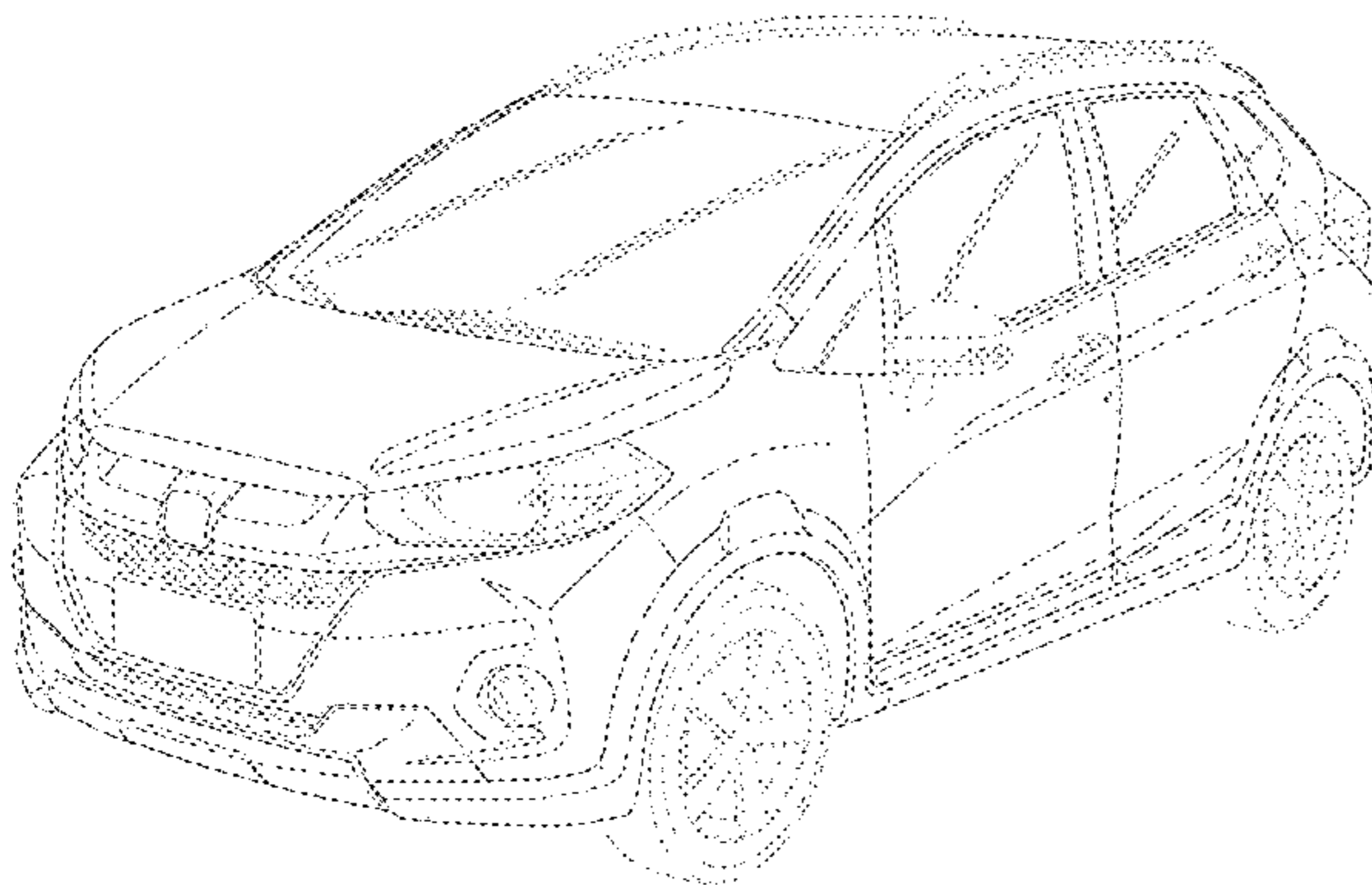

(56)

References Cited

OTHER PUBLICATIONS

Japanese magazine, "Nikkei Automotive Technology" (p. 94 of Issue No. 50 published on Apr. 11, 2015) showing "Hyundai Motor's Tucson". (1 page).

French magazine, "L'Automobile Magazine" (p. 42 of Issued No. 828 published on Apr. 10, 2015) showing "Citroen DS4". (1 page).

Office Action dated Dec. 27, 2016, issued in counterpart Japanese Application No. 2016-007289. (2 pages).

* cited by examiner

FIG.2

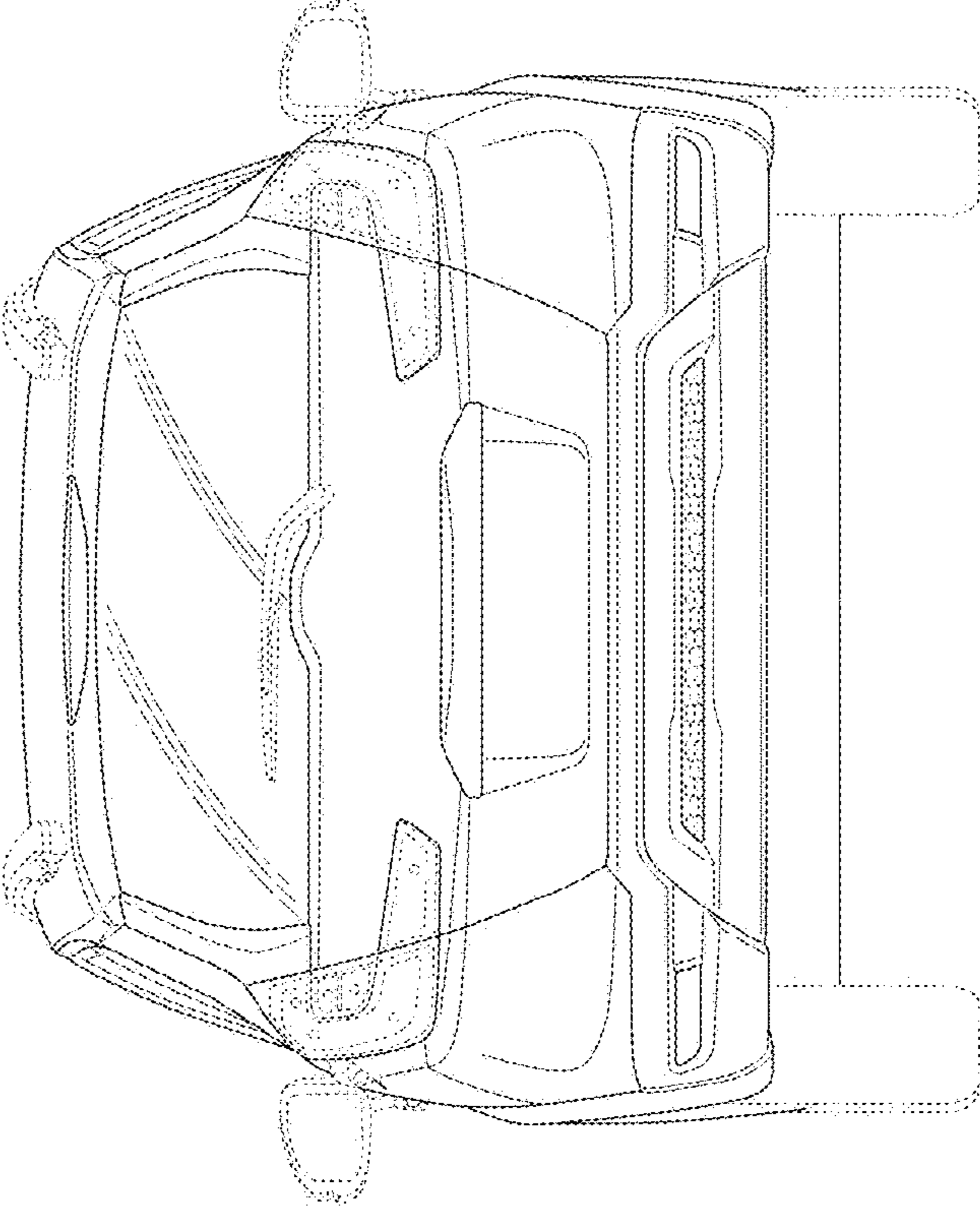

FIG.1

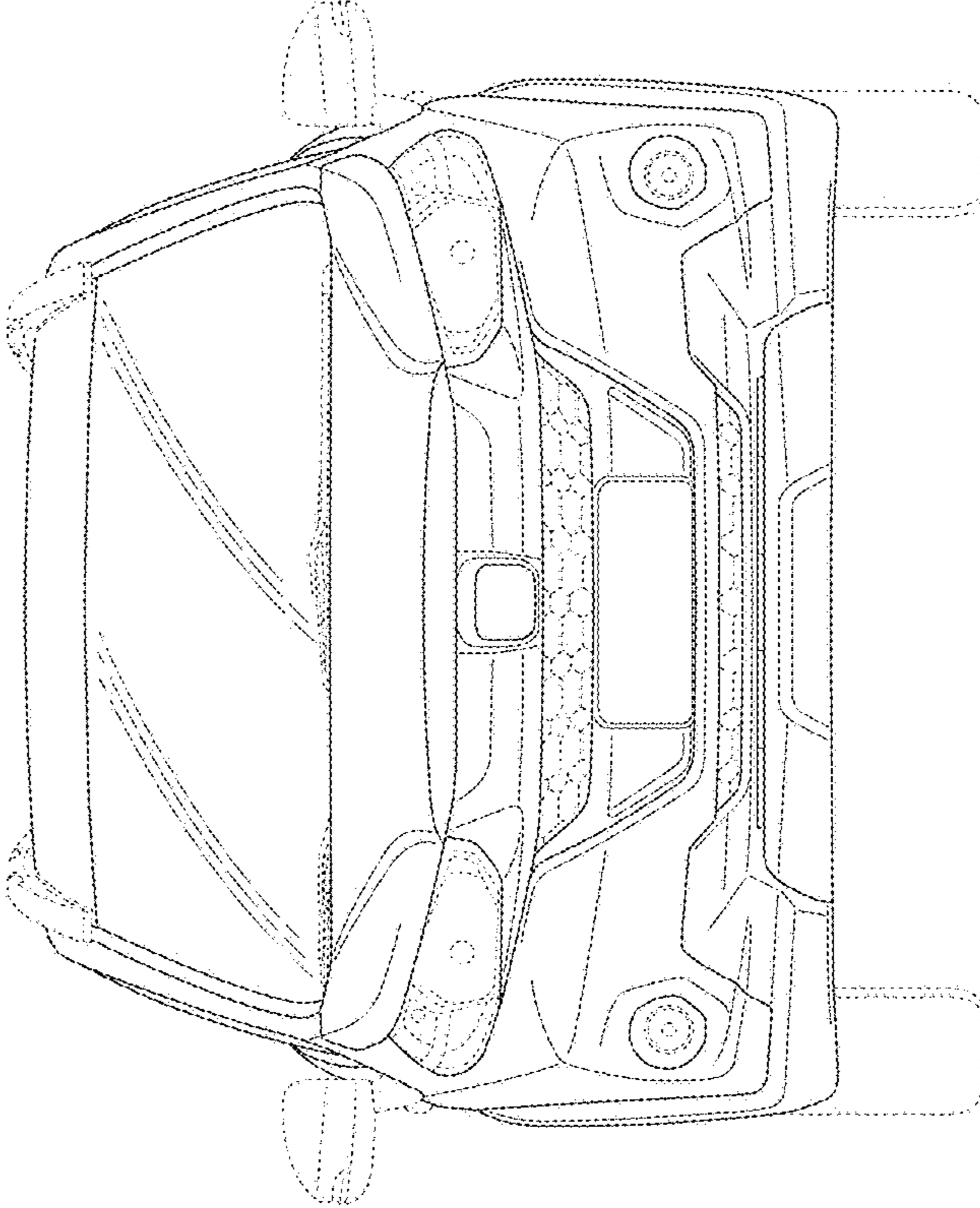

FIG.3

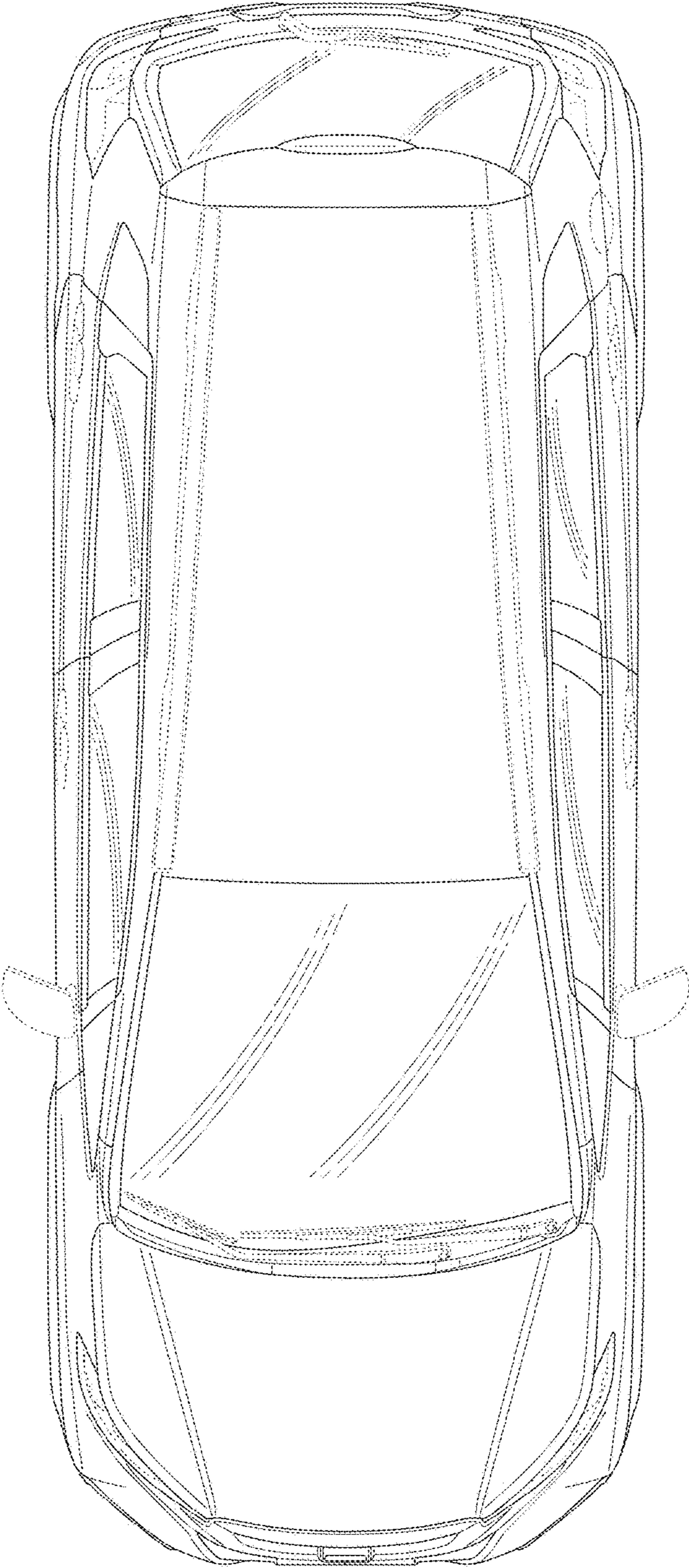

FIG.4

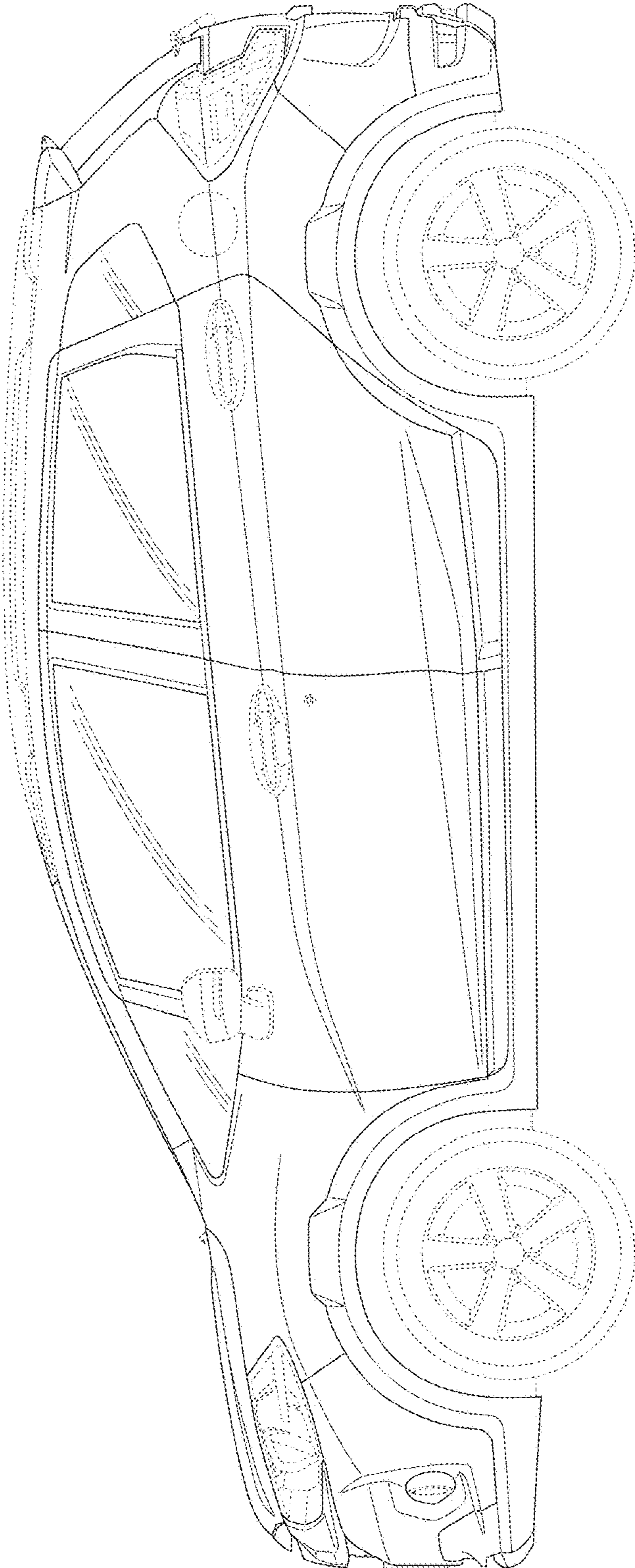

FIG. 5

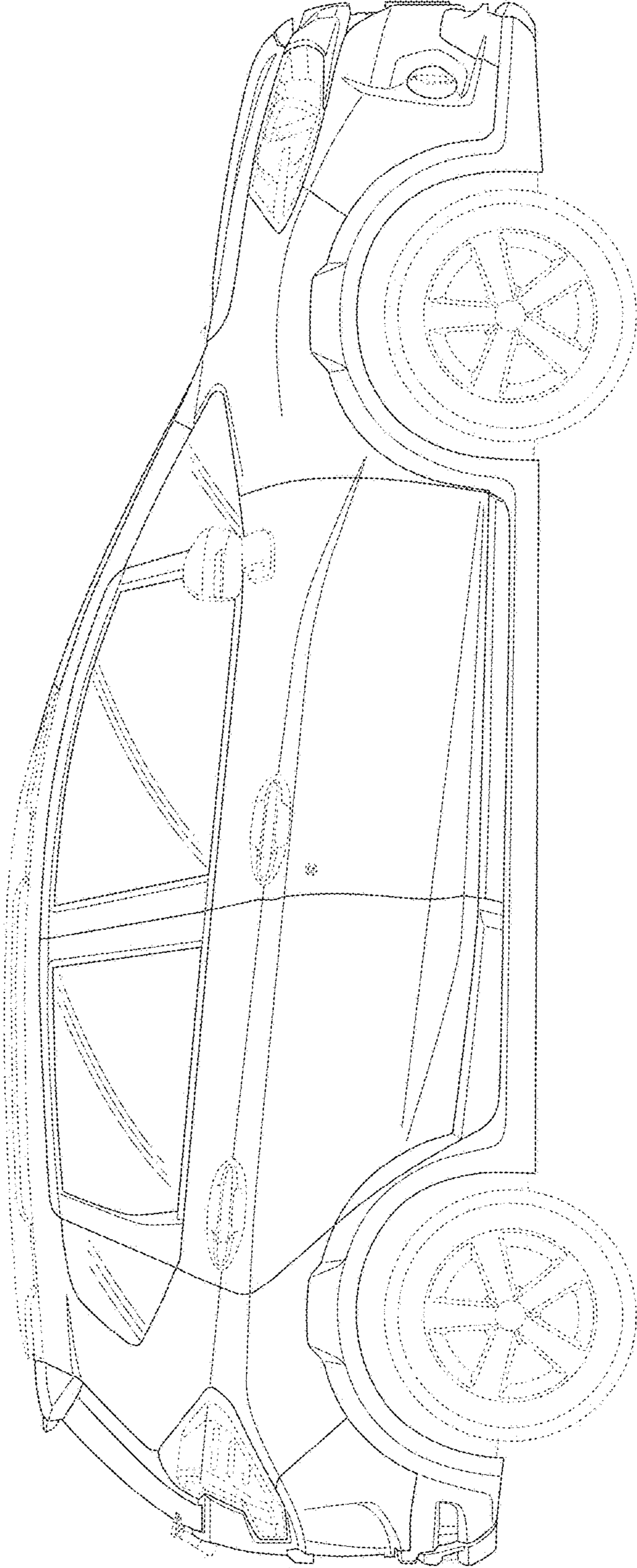
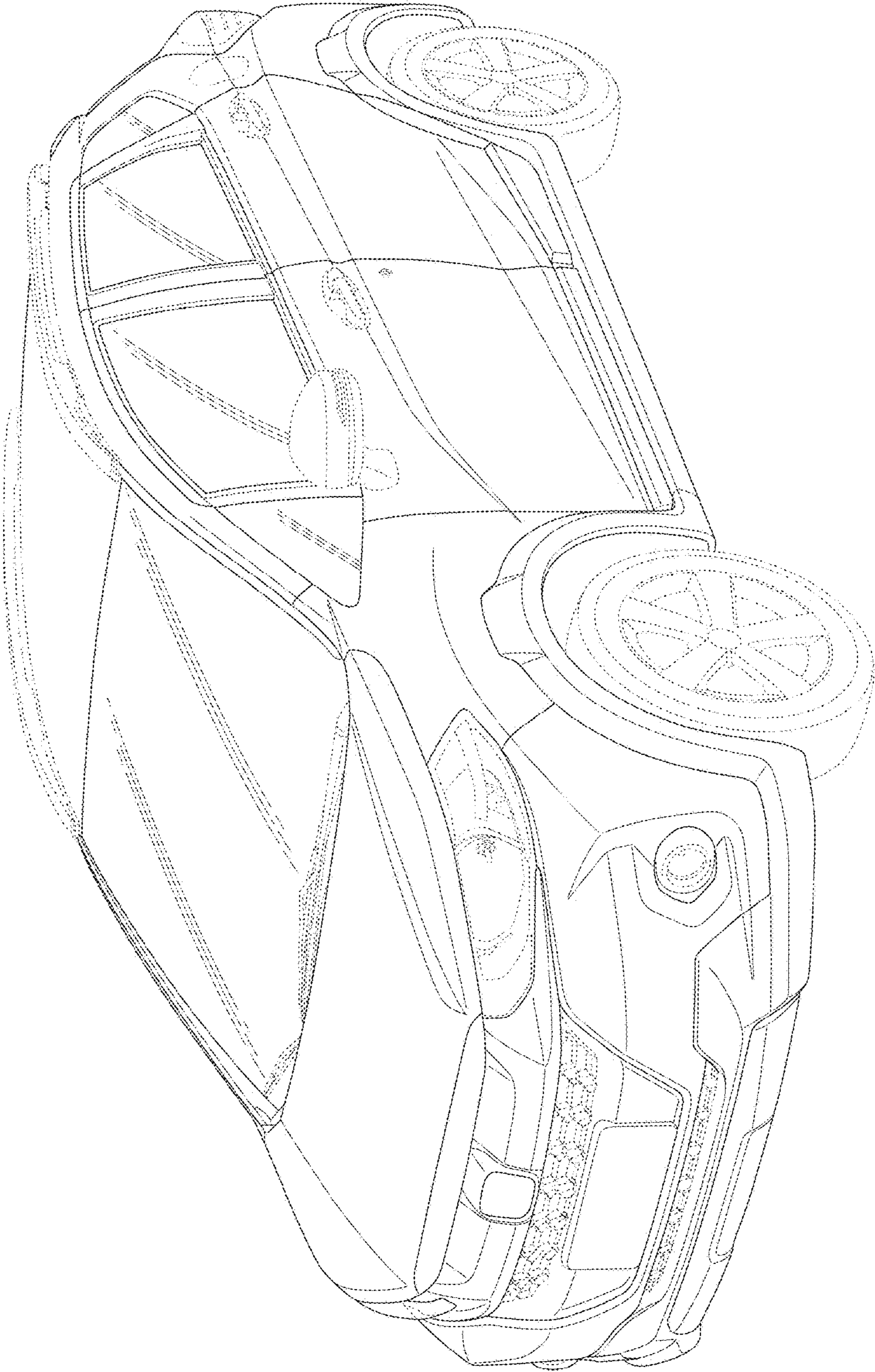

FIG. 6



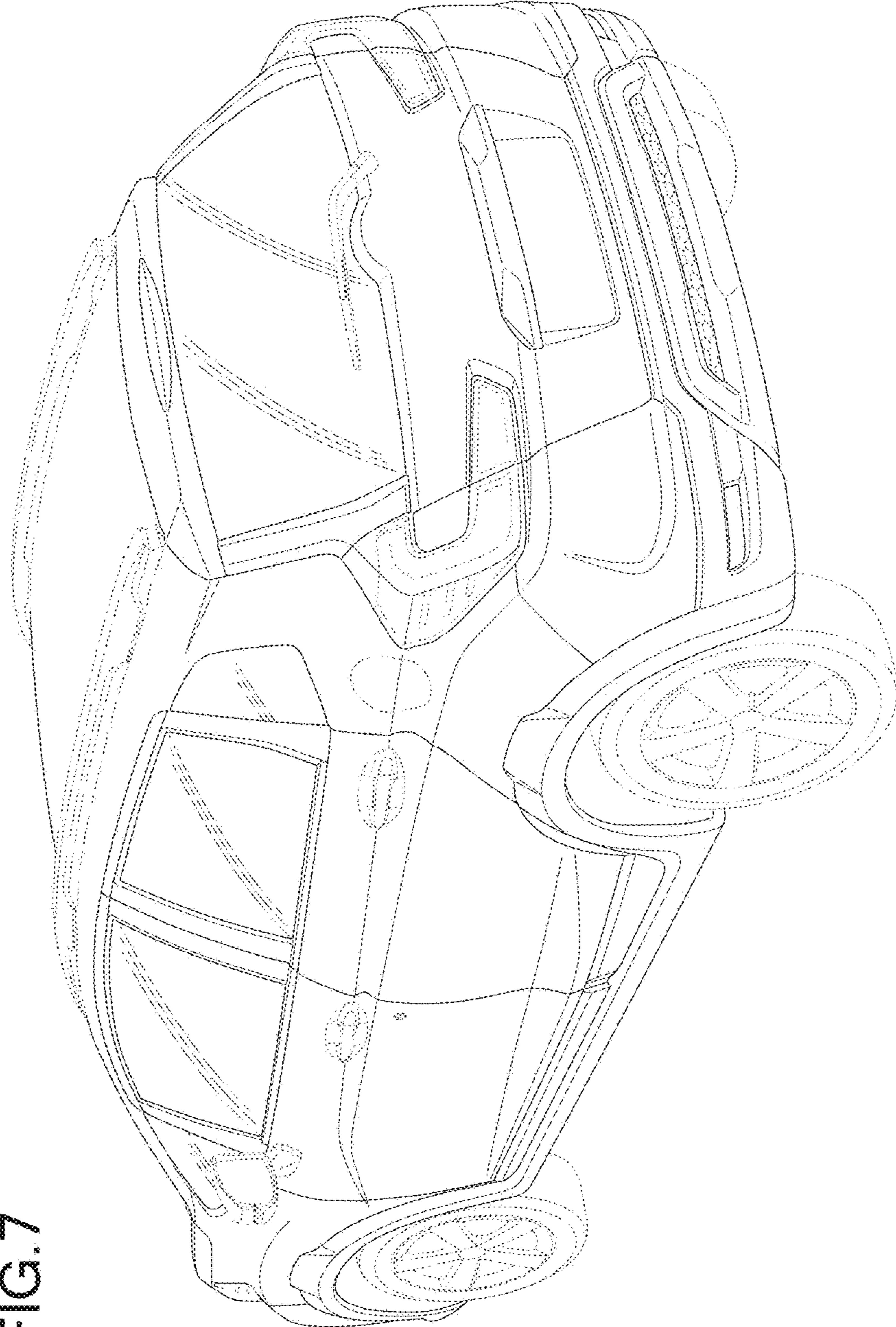

FIG.7