



US00D804136S

(12) **United States Design Patent** (10) **Patent No.:** **US D804,136 S**
Meyers (45) **Date of Patent:** **** Nov. 28, 2017**

- (54) **KEG TRANSPORTER**
- (71) Applicant: **Michael Meyers**, Conshohocken, PA (US)
- (72) Inventor: **Michael Meyers**, Conshohocken, PA (US)
- (**) Term: **15 Years**
- (21) Appl. No.: **29/580,656**
- (22) Filed: **Oct. 11, 2016**
- (51) **LOC (10) Cl.** **12-02**
- (52) **U.S. Cl.**
USPC **D34/26**
- (58) **Field of Classification Search**
USPC D34/12-27; 414/427, 539, 540, 454;
280/79.5, 47.26, 47.27, 79.6, 79.7, 655,
280/47.24, 47.28, 47.19, 47.23
CPC B62B 5/0438; B62B 5/06; B62B 2203/70;
B62B 1/264; B62B 2202/406
See application file for complete search history.

D798,001 S *	9/2017	Seeds	A01K 1/01 D30/161
2006/0071435 A1 *	4/2006	Zwack	B62B 1/264 280/47.27
2009/0014979 A1 *	1/2009	Snook	B62B 1/14 280/200
2015/0001820 A1 *	1/2015	Cormier	B62B 1/14 280/47.26

OTHER PUBLICATIONS

Webstaurantstore, "Bar Maid KPC100 Keg and Pail Truck," web pages, date of publication unknown, Webstaurant Store website <http://www.gotowebstore.com/929KPC100>, pp. 1-6.

* cited by examiner

Primary Examiner — Cynthia Ramirez
(74) *Attorney, Agent, or Firm* — Howson & Howson LLP

(57) **CLAIM**

The ornamental design for a keg transporter, as shown and described.

DESCRIPTION

FIG. 1 is a perspective view of the top, left side, and front of a keg transporter, showing my new design; FIG. 2 is a front elevational view thereof; FIG. 3 is a left side elevational view thereof; FIG. 4 is right side elevational view thereof; FIG. 5 is a top plan view thereof; FIG. 6 is a bottom plan view thereof; FIG. 7 is a rear elevational view thereof; and, FIG. 8 is a perspective view of the top, left side, and rear thereof.

The broken lines in FIG. 8 show environmental structure that forms no part of the claimed design.

1 Claim, 6 Drawing Sheets

(56) **References Cited**
U.S. PATENT DOCUMENTS

2,181,438 A *	11/1939	Peet	B62B 1/264 280/47.27
D192,557 S *	4/1962	Gatewood	D34/26
5,277,439 A *	1/1994	Pipes	B62B 1/002 280/47.2
D523,205 S *	6/2006	Burks	D34/24
D604,024 S *	11/2009	Chitty	D34/24
D635,320 S *	3/2011	Paoletto	D34/26
D642,351 S *	7/2011	Bozzo	D34/24
D762,937 S *	8/2016	Leban	D34/27
D771,895 S *	11/2016	Hsu	D34/24

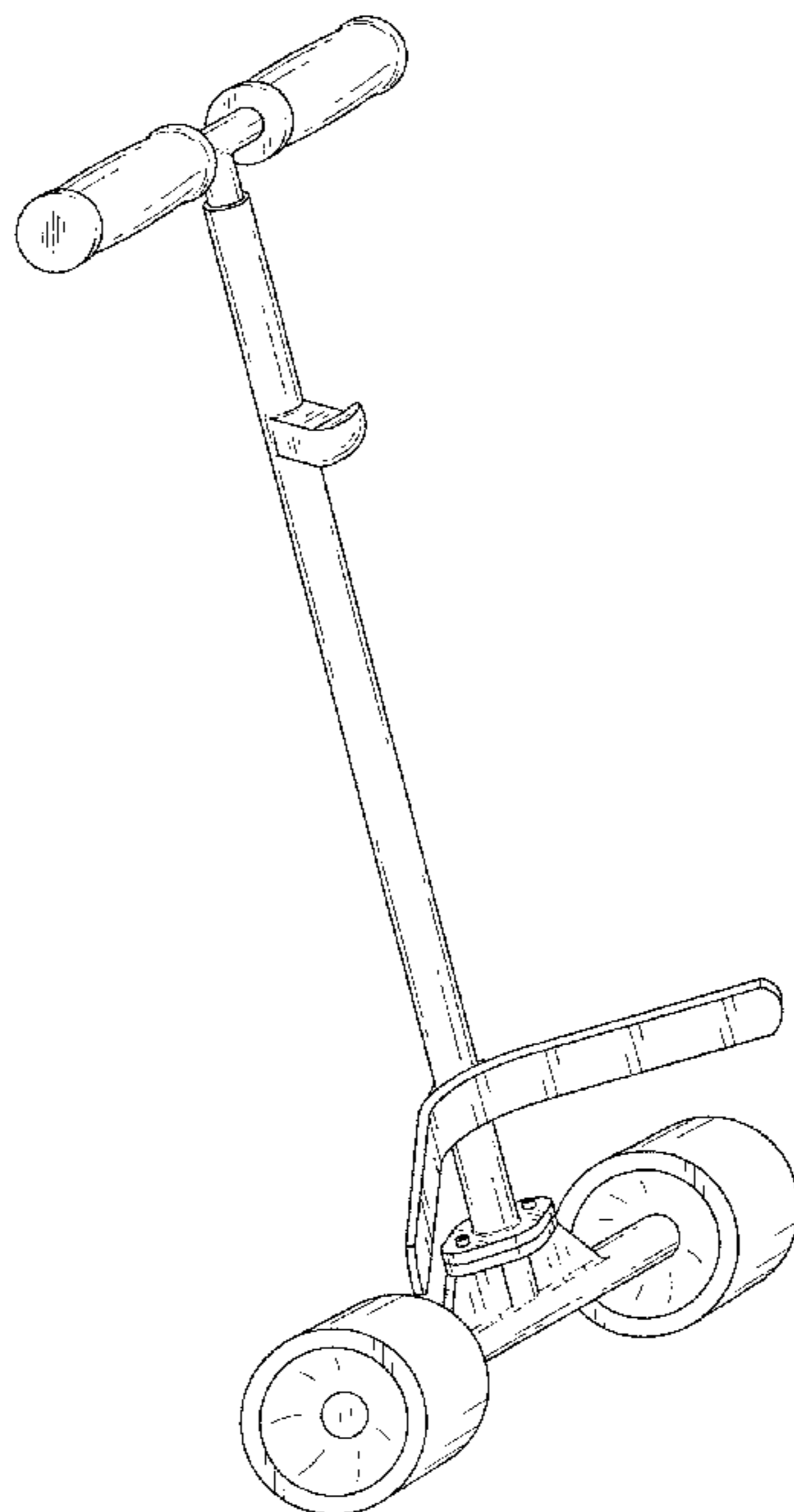

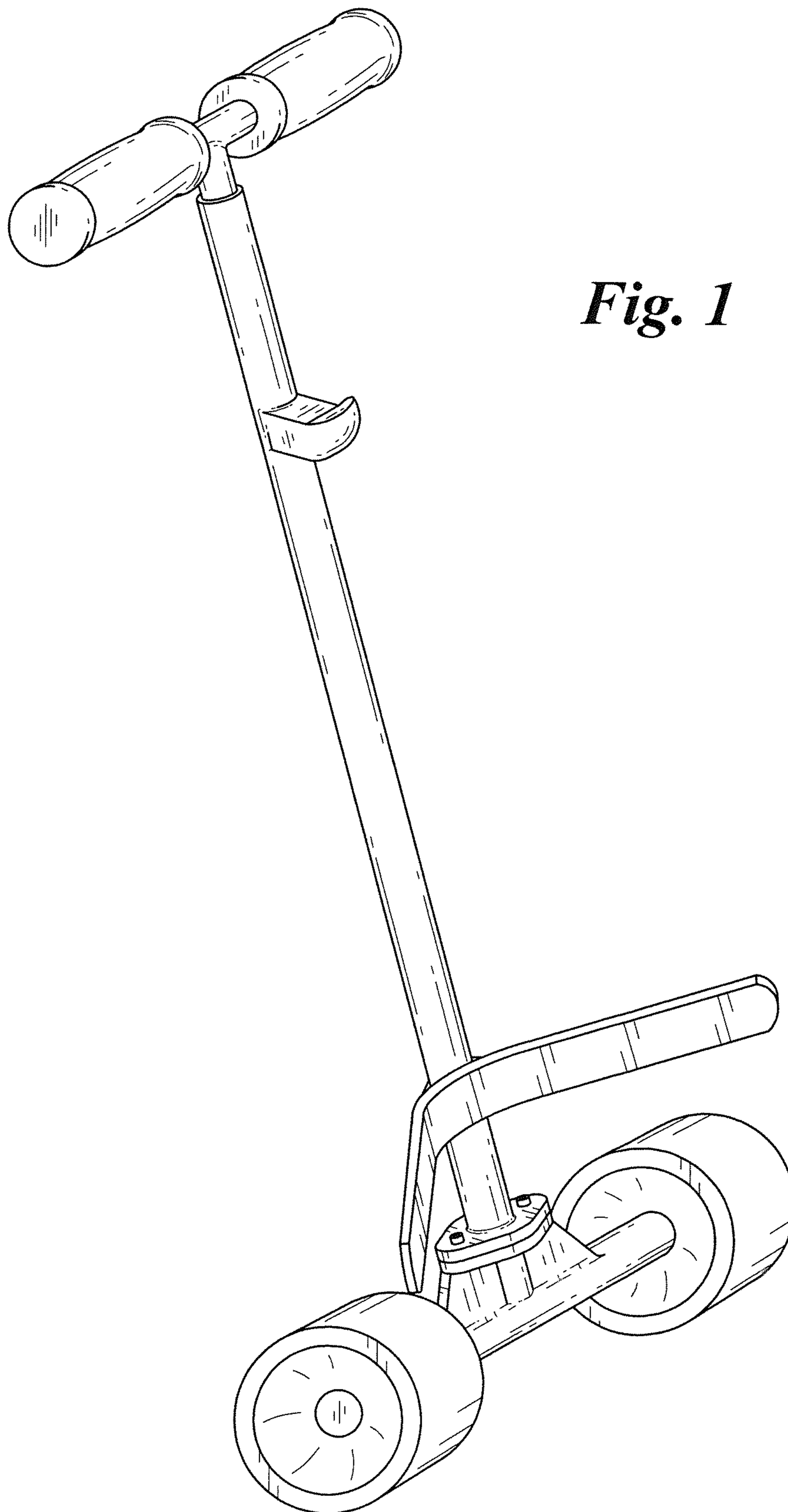

Fig. 1

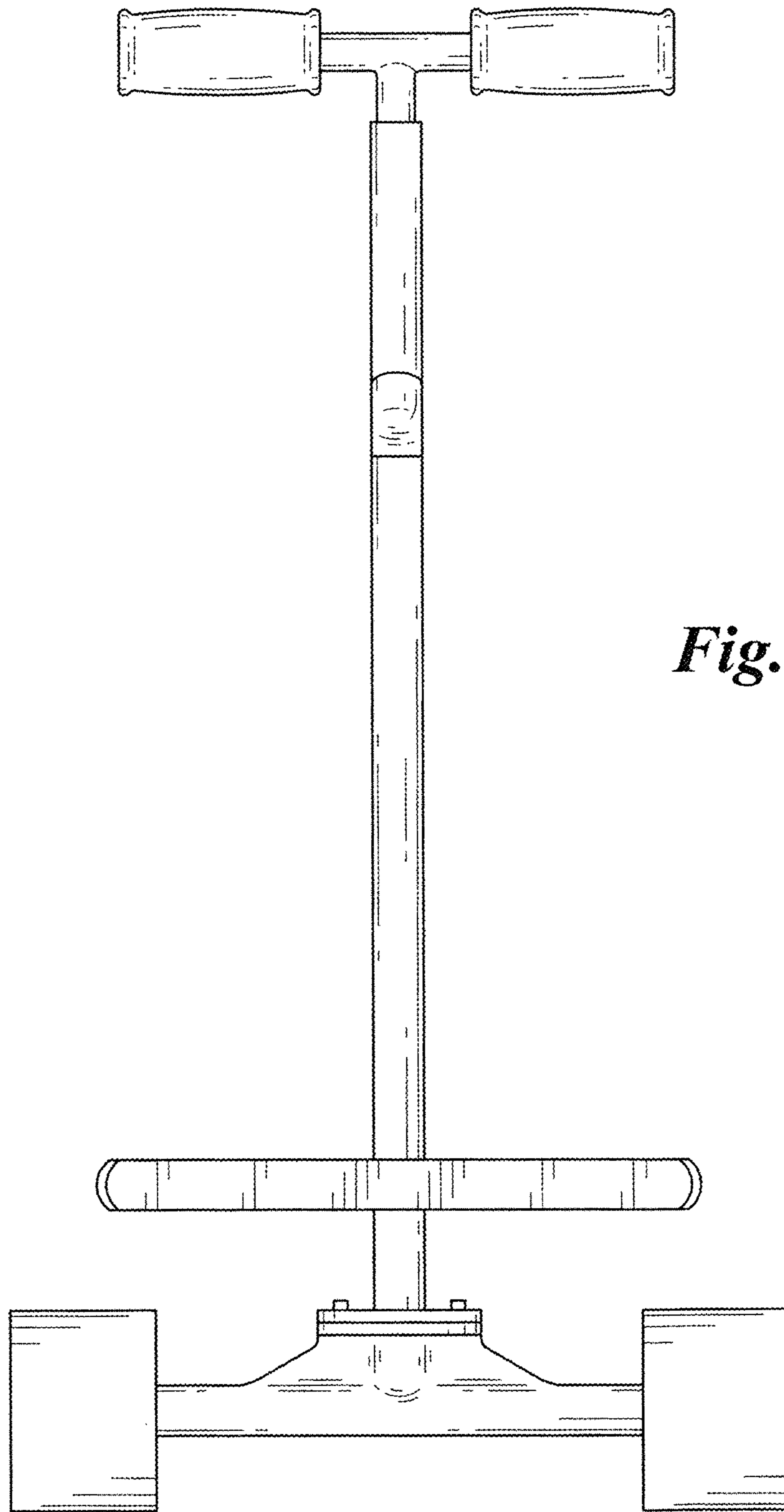

Fig. 2

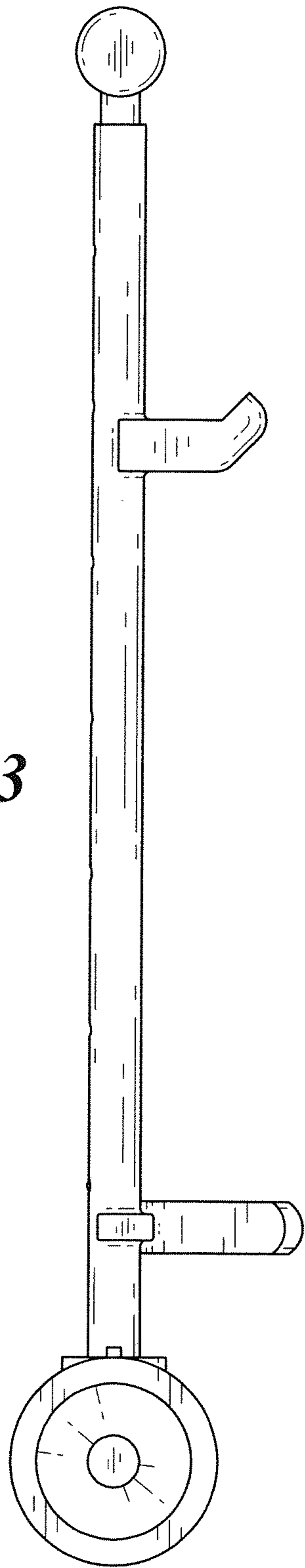

Fig. 3

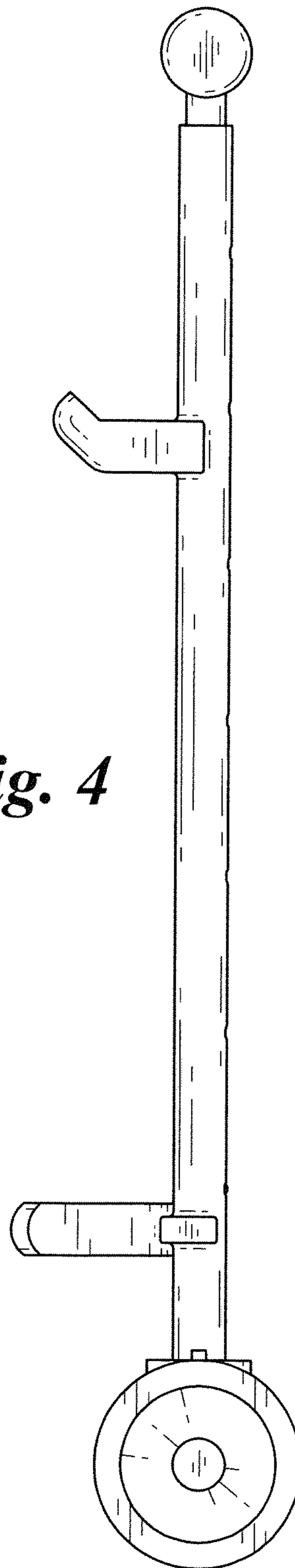

Fig. 4

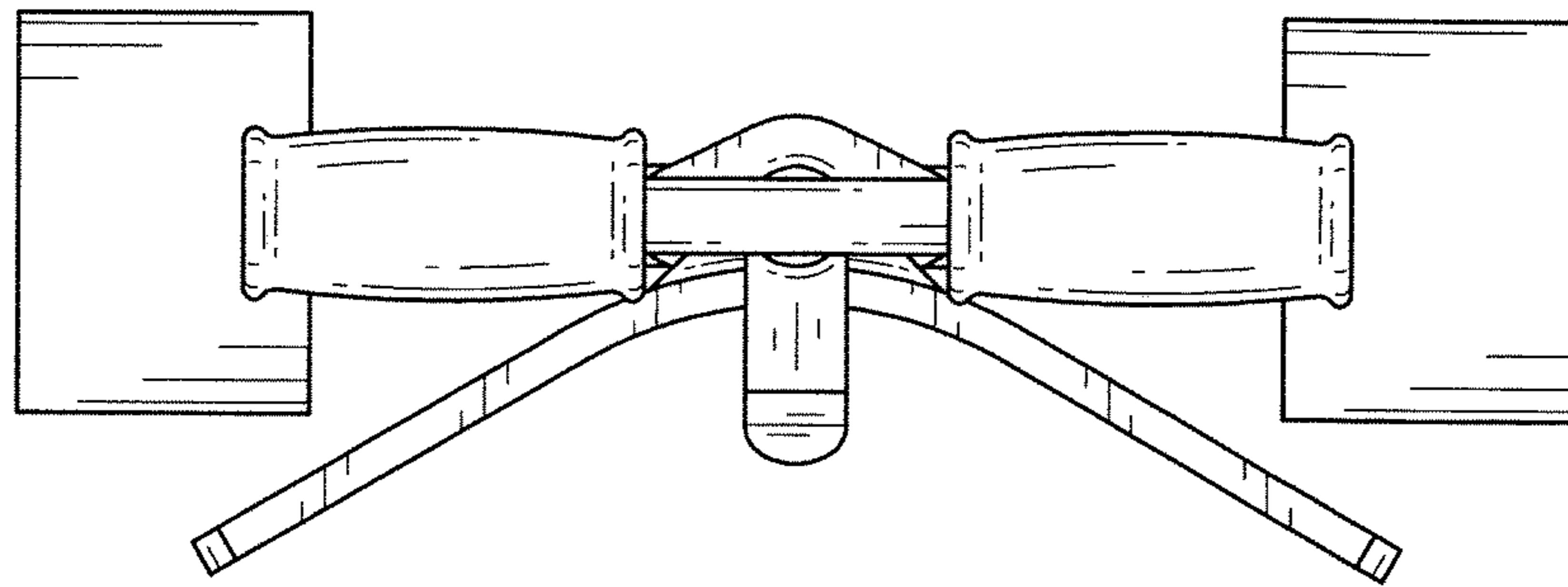

Fig. 5

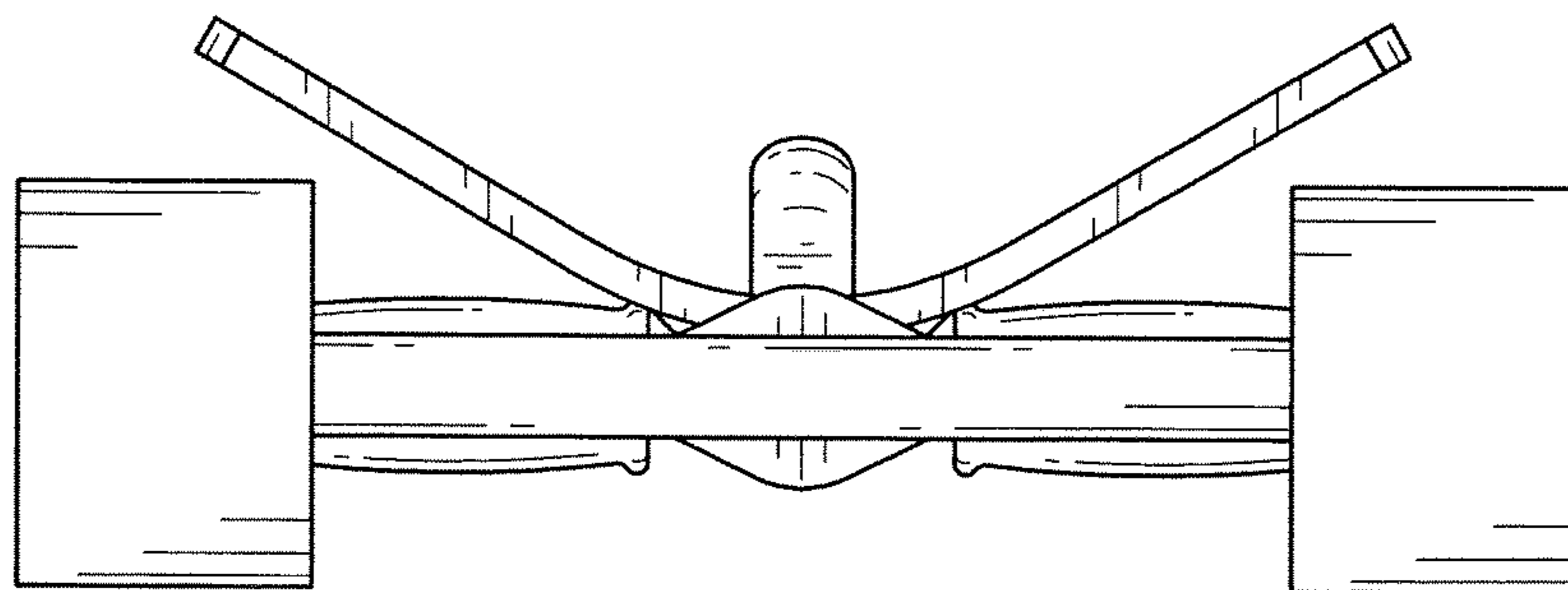

Fig. 6

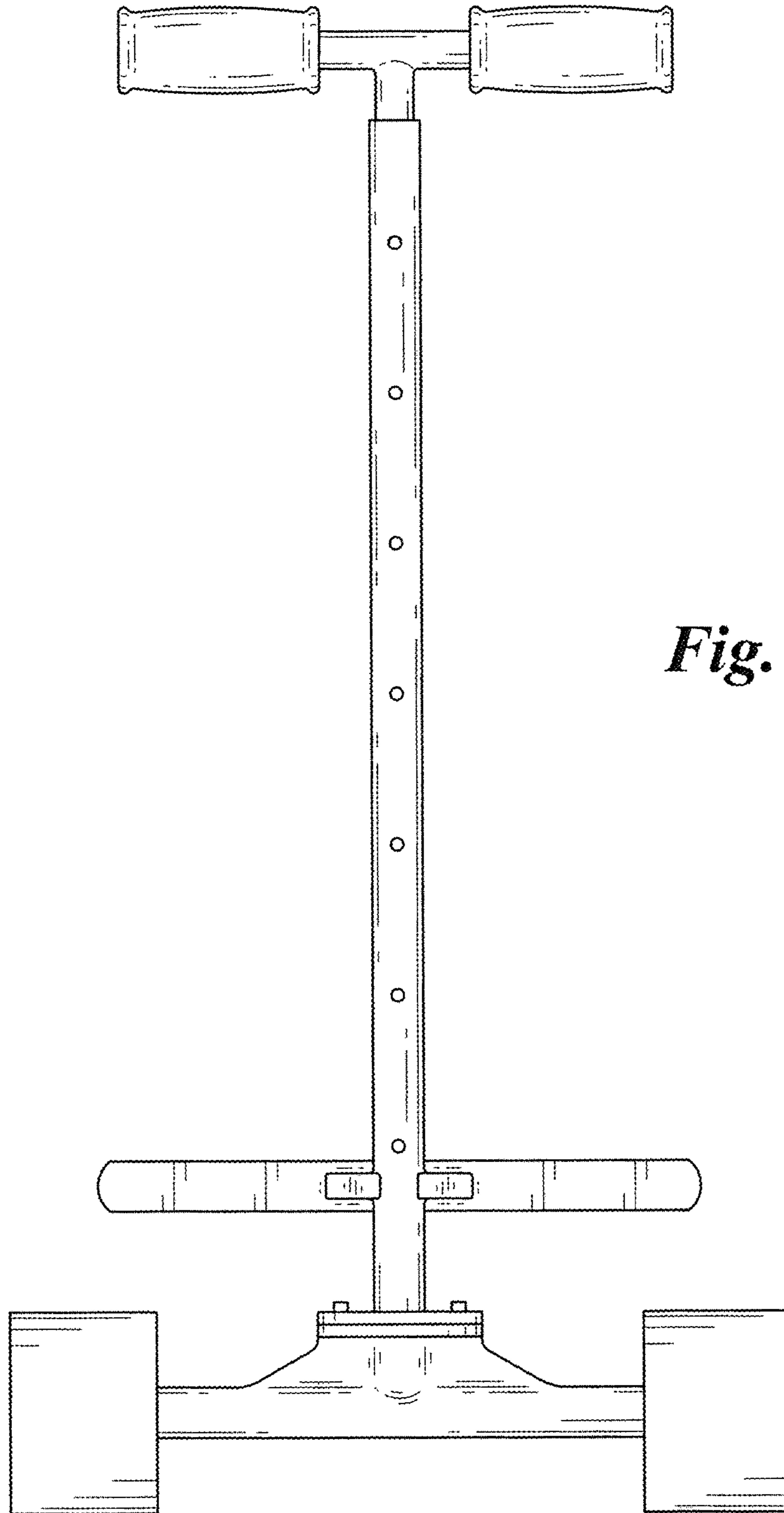

Fig. 7

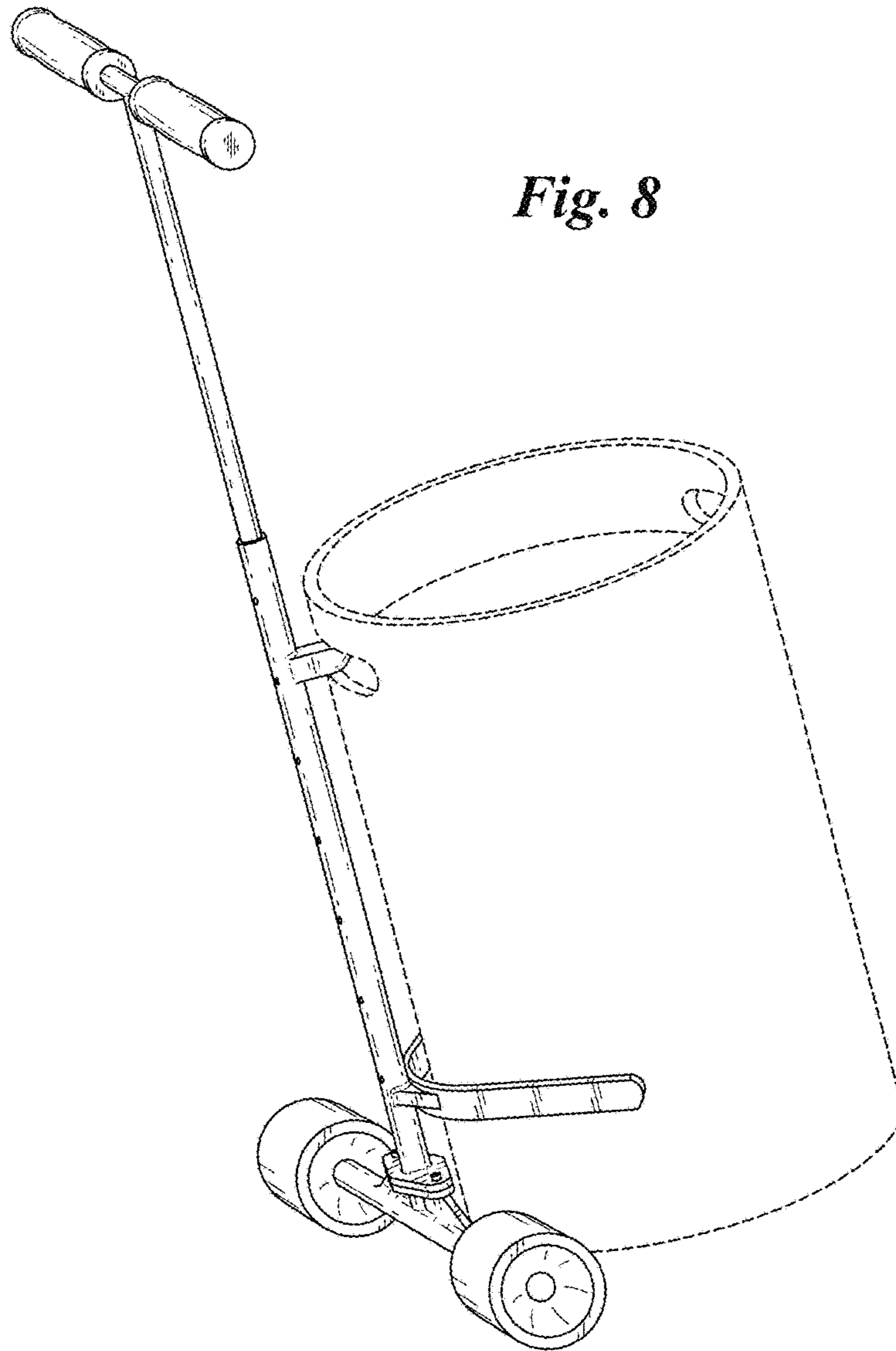

Fig. 8