

US00D804033S

(12) **United States Design Patent** (10) **Patent No.:** **US D804,033 S**
Wightman et al. (45) **Date of Patent:** **** Nov. 28, 2017**

(54) **BLOOD TESTING APPARATUS**

(56) **References Cited**

(71) Applicant: **Roche Diagnostics Operations, Inc.**,
Indianapolis, IN (US)
(72) Inventors: **Craig Ian Wightman**, Bristol (GB);
Johann Florian Wassermann, Horgen
(CH); **Michael John Unwin**,
Bishopston Bristol (GB)
(73) Assignee: **Roche Diagnostics Operations, Inc.**,
Indianapolis, IN (US)
(**) Term: **15 Years**
(21) Appl. No.: **29/583,390**
(22) Filed: **Nov. 4, 2016**

U.S. PATENT DOCUMENTS

5,281,395 A	1/1994	Markart et al.	
D406,895 S *	3/1999	Byrd	D24/169
D545,436 S	6/2007	Padain	
D627,068 S	11/2010	Brauer et al.	
D648,029 S *	11/2011	Presta	D24/169
8,427,817 B2 *	4/2013	Lewis	A61B 5/14532 361/679.02
8,515,775 B2	8/2013	Galley et al.	
D690,422 S *	9/2013	Oka	D24/169
D696,404 S *	12/2013	Golnik	D24/169
D721,177 S *	1/2015	Ahlstrom	D24/169
D724,223 S *	3/2015	Nishiyama	D24/169
9,022,931 B2	5/2015	Brauer et al.	
D734,468 S *	7/2015	Murakami	D24/169
2012/0095316 A1	4/2012	Lewis et al.	
2012/0095318 A1	4/2012	Galley et al.	
2012/0095691 A1	4/2012	Galley et al.	

(Continued)

Primary Examiner — Anhdao Doan

(74) Attorney, Agent, or Firm — Dinsmore & Shohl LLP

(57) **CLAIM**

The ornamental design for a blood testing apparatus, as shown and described.

Related U.S. Application Data

(62) Division of application No. 29/512,655, filed on Dec. 22, 2014.

Foreign Application Priority Data

Jun. 27, 2014 (EP) 002492397-0001
Jun. 27, 2014 (EP) 002492397-0002
(51) **LOC (10) Cl.** **24-01**
(52) **U.S. Cl.**
USPC **D24/169**
(58) **Field of Classification Search**
USPC D24/107, 147, 169, 186, 216, 223, 231;
D10/78, 81
CPC G01N 33/66; G01N 33/49; G01N 33/493;
A61B 5/14532; A61B 2560/0412; A61B
2560/0443; A61B 2560/0462
See application file for complete search history.

DESCRIPTION

FIG. 1 is a right side, front perspective view of a blood testing apparatus illustrating our new design;
FIG. 2 is a left side, rear perspective view of FIG. 1 thereof;
FIG. 3 is a front view of FIG. 1 thereof;
FIG. 4 is a rear view of FIG. 1 thereof;
FIG. 5 is a bottom plan view of FIG. 1 thereof;
FIG. 6 is a top plan view of FIG. 1 thereof; and,
FIG. 7 is a left side view of FIG. 1 thereof, the right side being the same.
The broken lines in the drawing views illustrate portions of the blood testing apparatus that form no part of the claimed design.

1 Claim, 7 Drawing Sheets

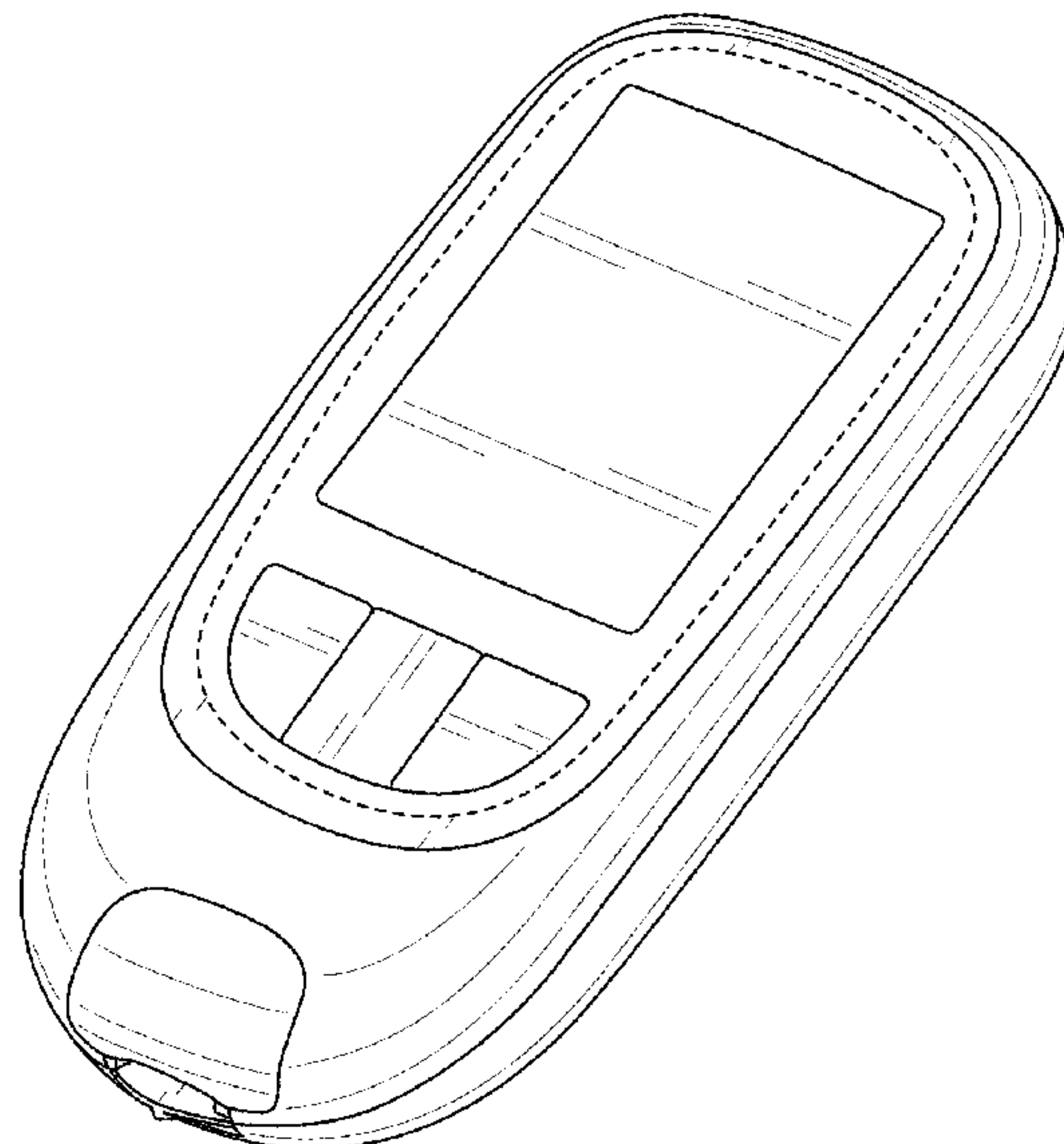

(56)

References Cited

U.S. PATENT DOCUMENTS

2012/0165640 A1 6/2012 Galley et al.
2012/0266251 A1 10/2012 Birtwhistle et al.

* cited by examiner

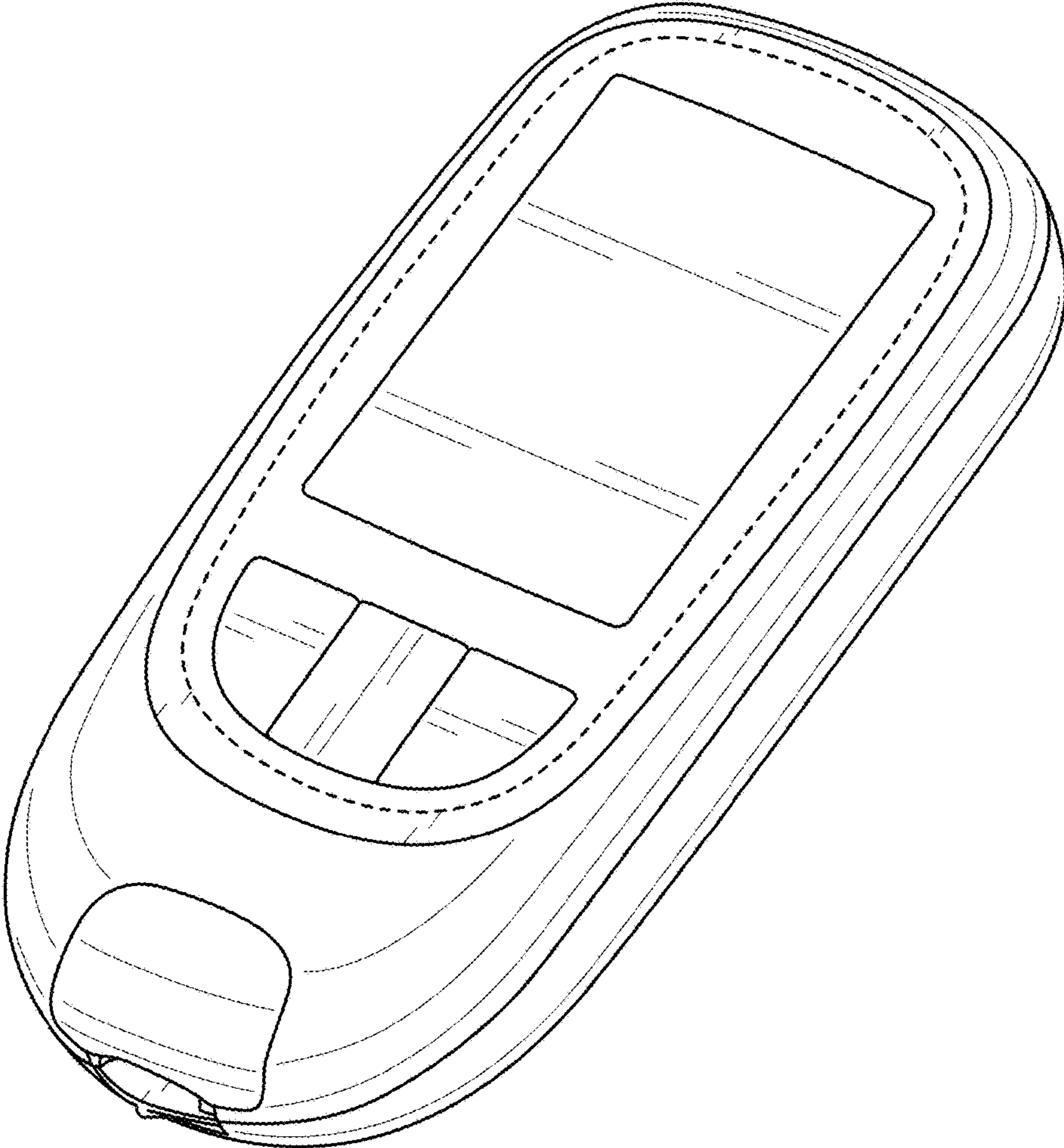

FIG. 1

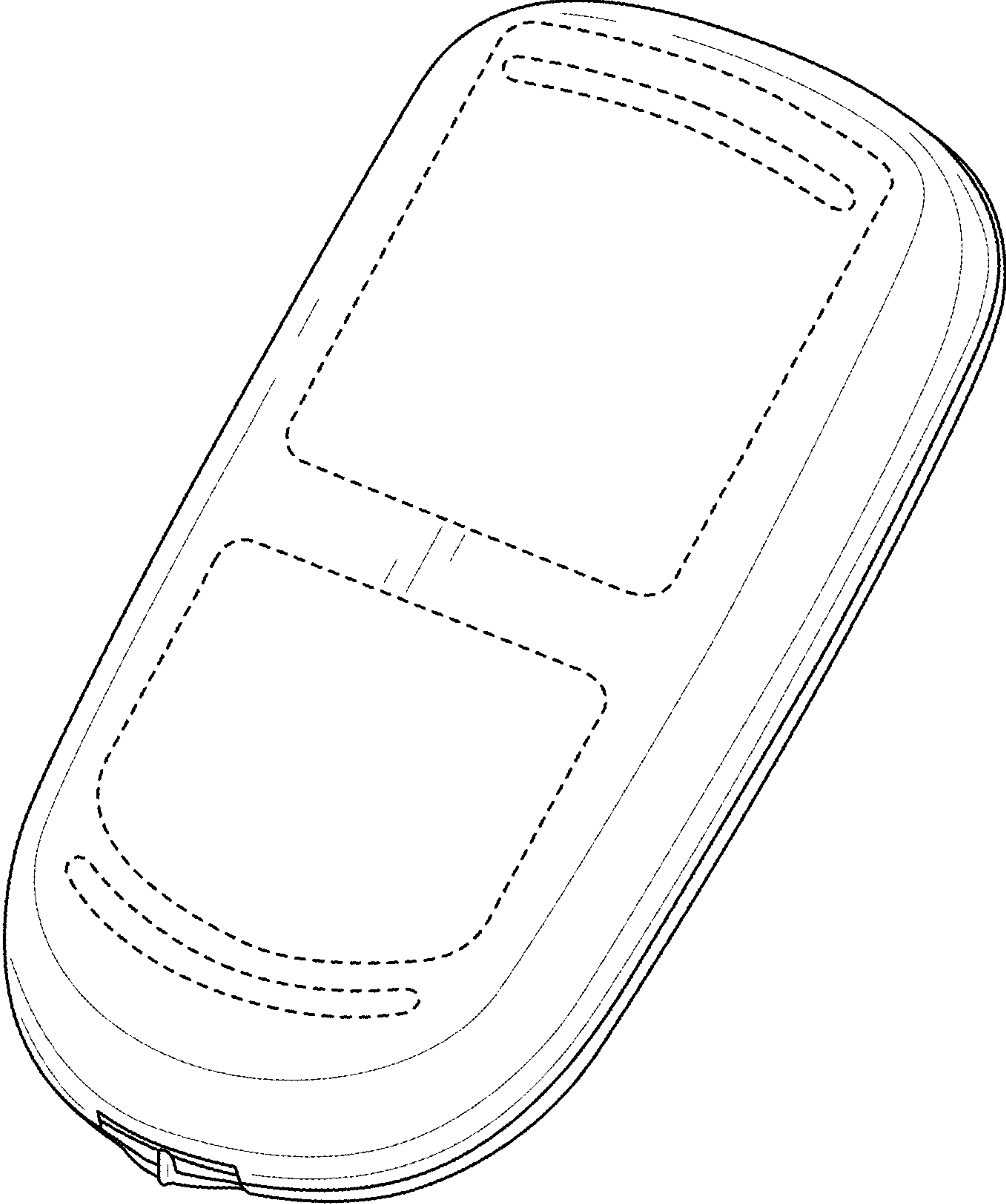

FIG. 2

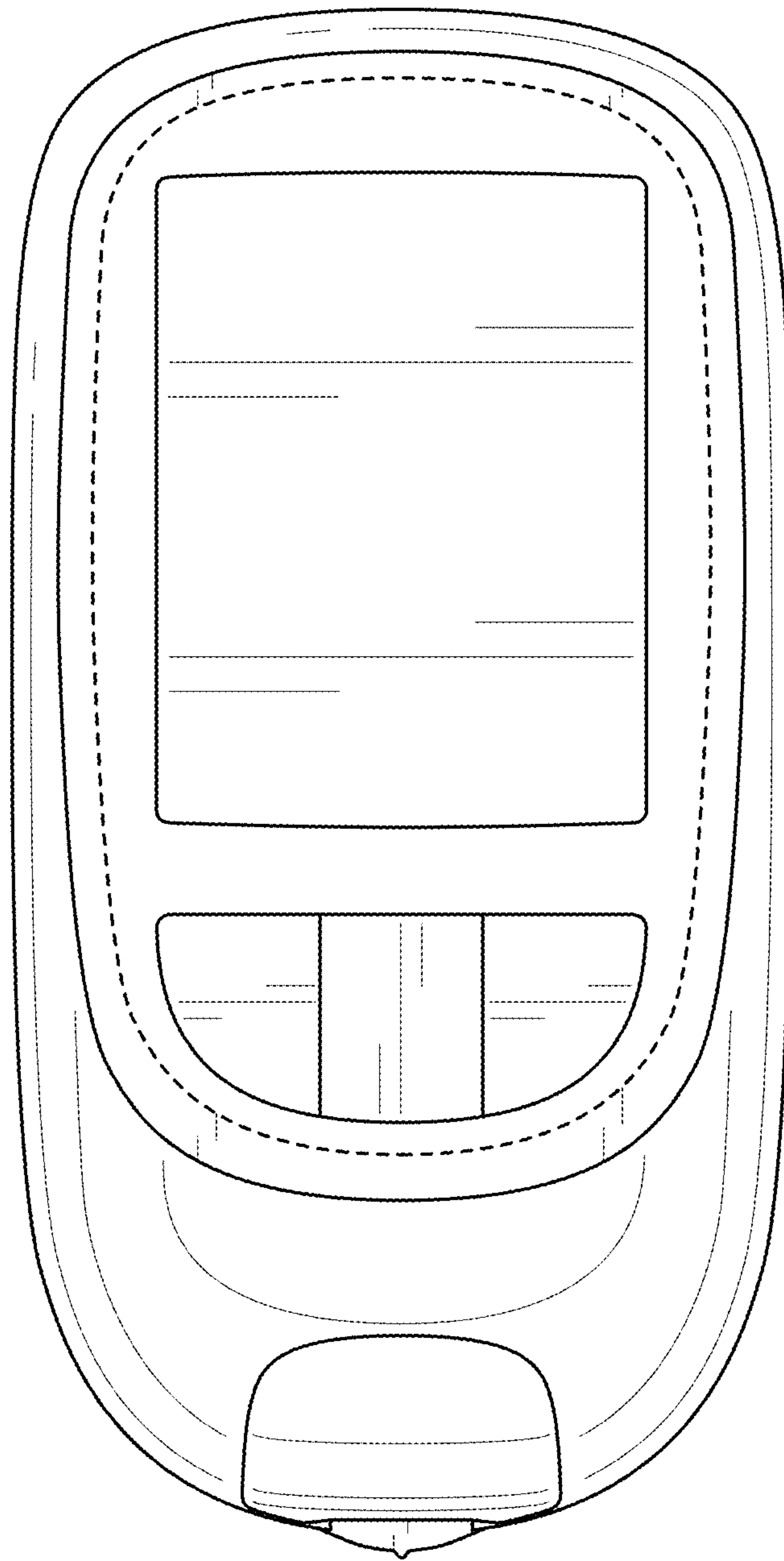

FIG. 3

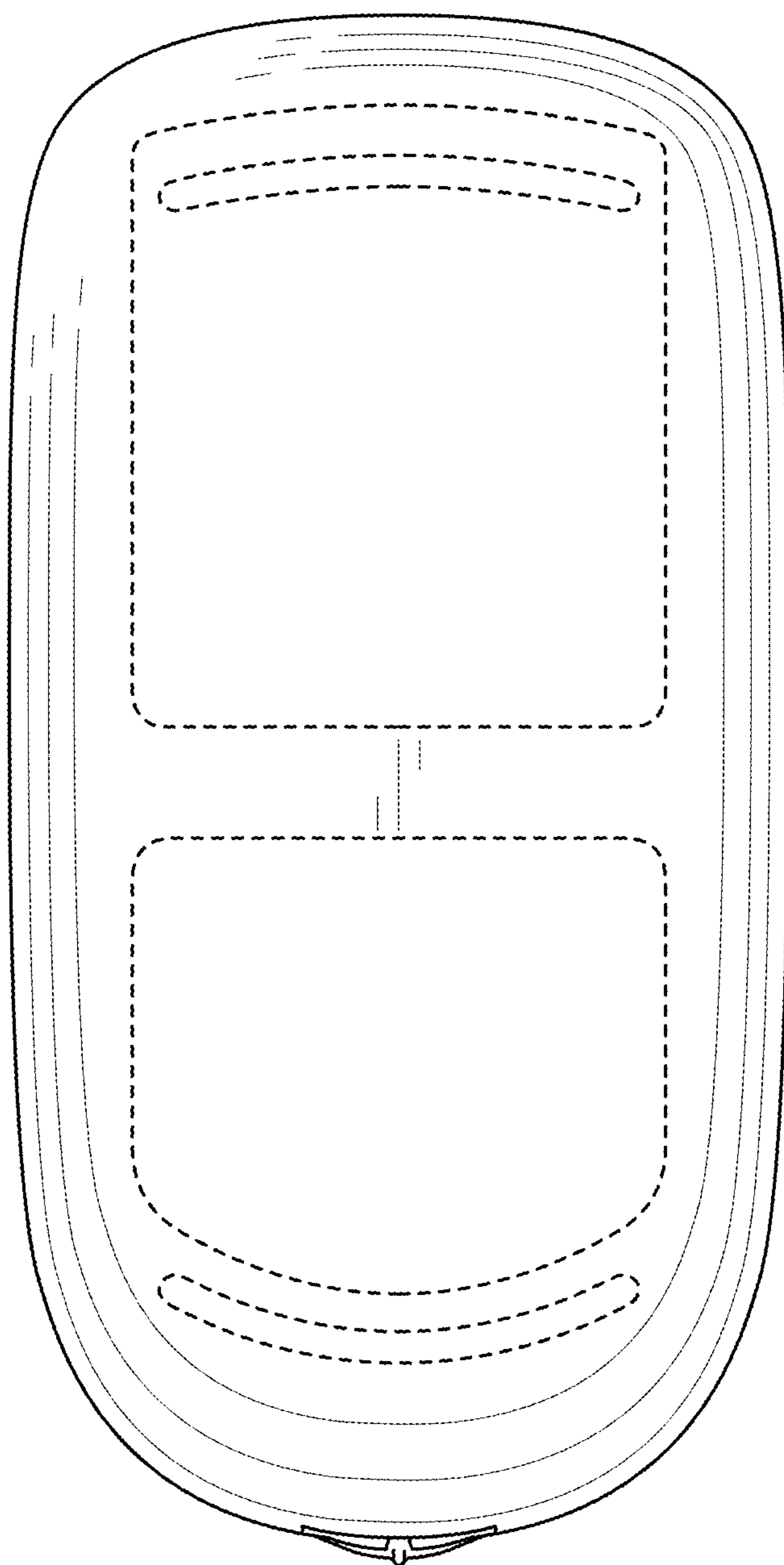

FIG. 4

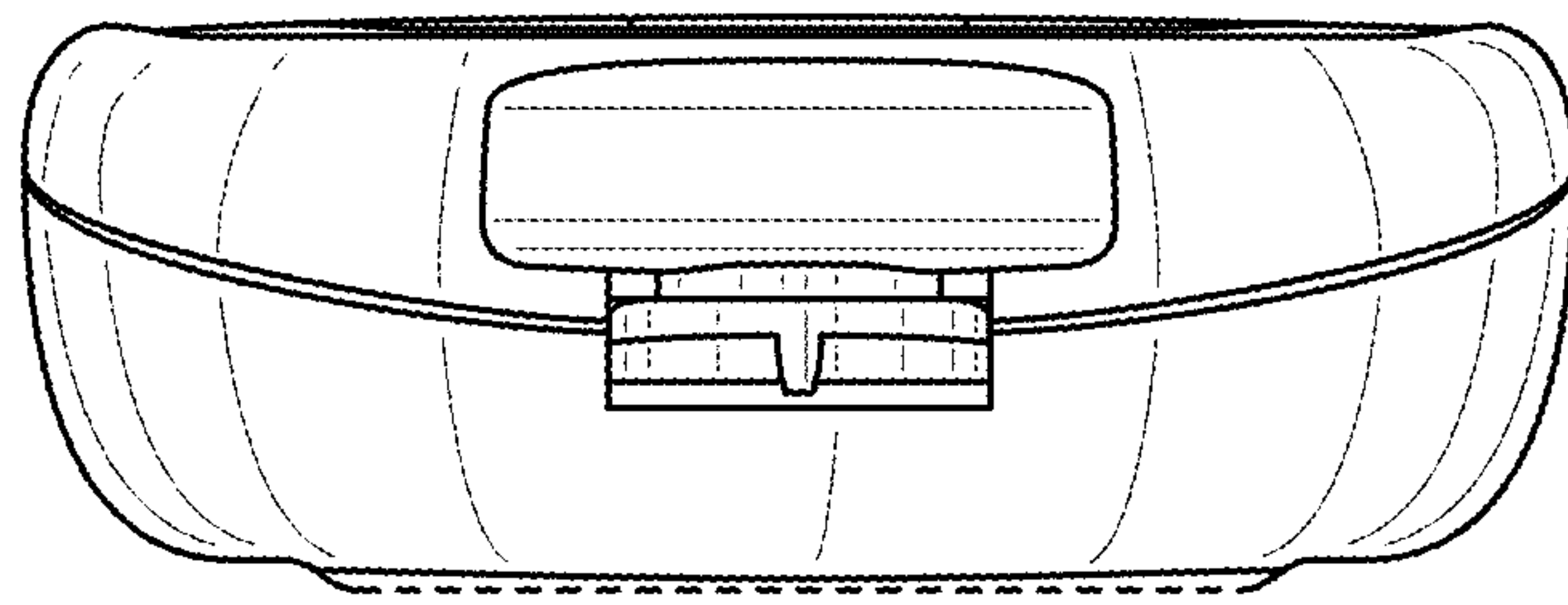

FIG. 5

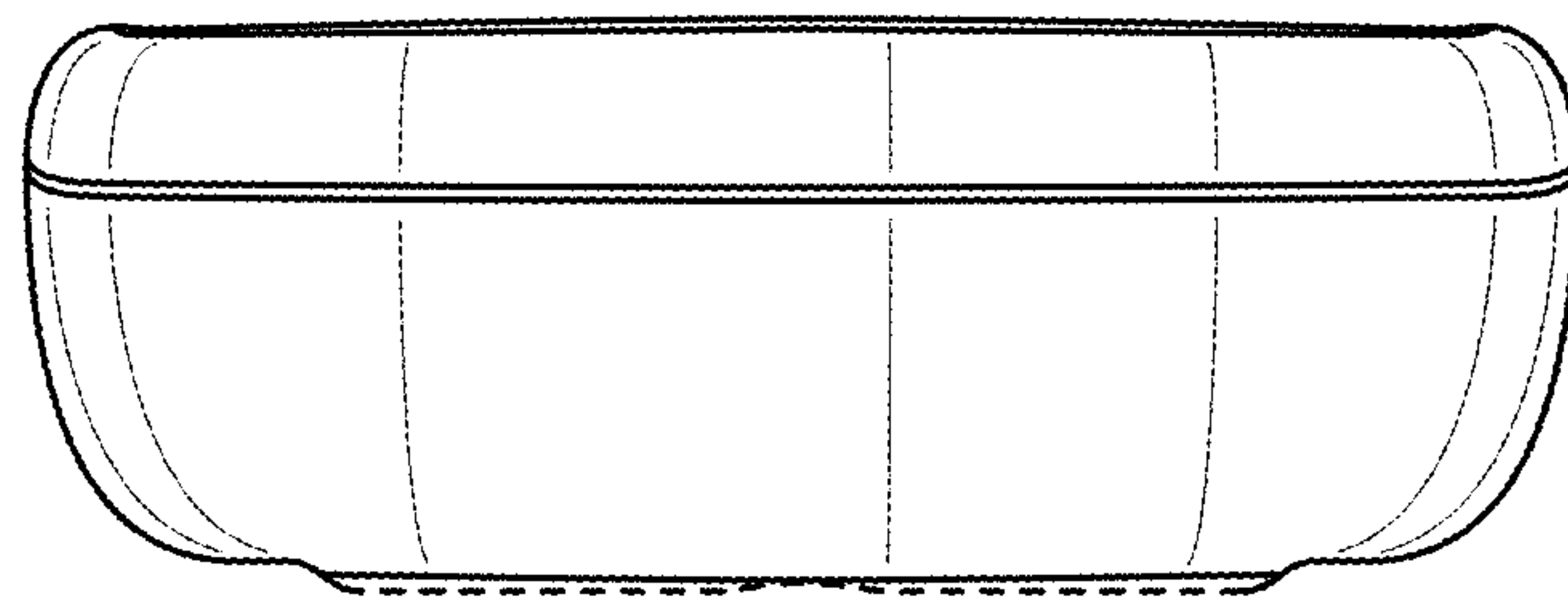

FIG. 6

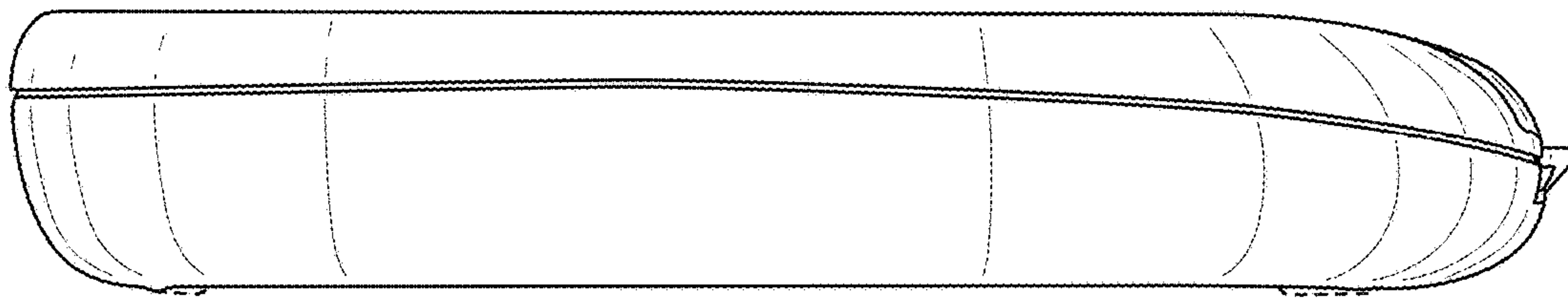

FIG. 7