



US00D803900S

(12) **United States Design Patent** (10) **Patent No.:** **US D803,900 S**
Serrurier et al. (45) **Date of Patent:** **** Nov. 28, 2017**

(54) **TIP FOR A GROUND ENGAGING MACHINE IMPLEMENT**

(71) Applicant: **Caterpillar Inc.**, Peoria, IL (US)

(72) Inventors: **Douglas Serrurier**, Morton, IL (US);
Jason Jura, Peoria, IL (US); **Eric Sinn**,
East Peoria, IL (US); **Mihai Mircea**
Balan, Dunlap, IL (US)

(73) Assignee: **Caterpillar Inc.**, Peoria, IL (US)

(**) Term: **15 Years**

(21) Appl. No.: **29/587,747**

(22) Filed: **Dec. 15, 2016**

(51) **LOC (10) Cl.** **15-03**

(52) **U.S. Cl.**
USPC **D15/29; D15/28**

(58) **Field of Classification Search**
USPC D15/11, 28, 29; 37/456, 452, 450, 446,
37/454, 449, 453, 455, 903; 403/379.5,
403/DIG. 1; 111/152; 172/724, 730,
172/766, 770, 771, 721, 713, 699, 772
CPC Y10T 29/49826; Y10T 403/589; Y10T
403/7018; Y10T 403/7075; E02F 9/28;
E02F 9/2825; E02F 9/2833; E02F 9/2866;
E02F 9/2858; E02F 9/2808; E02F 9/2841
See application file for complete search history.

(56) **References Cited**

U.S. PATENT DOCUMENTS

| | | |
|-------------|---------|---------------|
| 1,220,186 A | 3/1917 | Chambers |
| 1,384,701 A | 7/1921 | McMonegal |
| 1,571,782 A | 2/1926 | Andrews |
| 1,856,930 A | 5/1932 | Robin |
| 2,256,488 A | 9/1941 | Murtaugh |
| 2,427,651 A | 9/1947 | Baer |
| D182,143 S | 2/1958 | Petersen |
| 2,982,035 A | 5/1961 | Stephenson |
| 3,019,537 A | 2/1962 | Stephenson |
| 3,079,710 A | 3/1963 | Larsen et al. |
| 3,312,004 A | 4/1967 | Johnson |
| 3,623,247 A | 11/1971 | Stepe |

| | | |
|-------------|---------|----------------|
| 3,774,324 A | 11/1973 | Lafond |
| 3,823,496 A | 7/1974 | Querci et al. |
| 3,832,077 A | 8/1974 | Von Mehren |
| 4,027,408 A | 6/1977 | Ramella et al. |
| D251,431 S | 3/1979 | Klett et al. |
| D252,461 S | 7/1979 | Korpi |
| 4,182,057 A | 1/1980 | Klett et al. |
| D255,119 S | 5/1980 | Korpi |
| 4,231,173 A | 11/1980 | Davis |
| D275,859 S | 10/1984 | Nilsson |
| 4,481,728 A | 11/1984 | Mulder et al. |
| 4,516,340 A | 5/1985 | Launder |

(Continued)

FOREIGN PATENT DOCUMENTS

| | | |
|----|-----------|---------|
| CL | 2068-1995 | 10/1996 |
| CL | 391-1998 | 11/1998 |

(Continued)

OTHER PUBLICATIONS

Caterpillar Inc., Cat® K Series™ Tooth Systems, brochure (4 pages), 2006.

(Continued)

Primary Examiner — Mark Goodwin
(74) *Attorney, Agent, or Firm* — Saidman DesignLaw Group

(57) **CLAIM**

The ornamental design for a tip for a ground engaging machine implement, as shown and described.

DESCRIPTION

FIG. 1 is a front perspective view of a tip for a ground engaging machine implement showing our new design; FIG. 2 is a front view thereof; FIG. 3 is a rear view thereof; FIG. 4 is a left side view thereof; FIG. 5 is a right side view thereof; FIG. 6 is a top view thereof; and, FIG. 7 is a bottom view thereof. Grayscale shading represents contour.

1 Claim, 3 Drawing Sheets

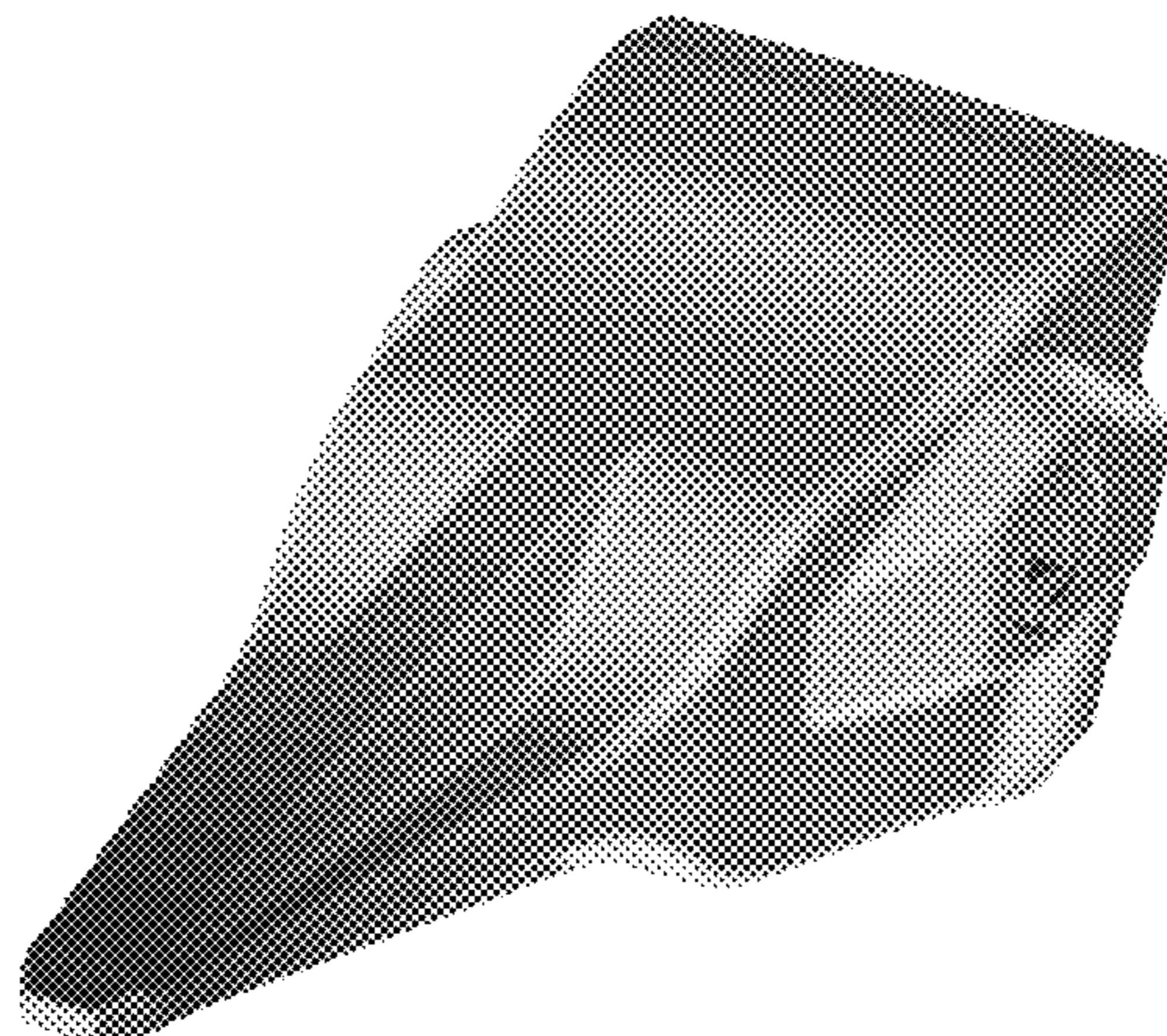

(56)

References Cited

U.S. PATENT DOCUMENTS

D296,442 S 6/1988 Broomhall
 4,761,900 A 8/1988 Emrich
 4,776,113 A 10/1988 Bedford et al.
 4,848,013 A 7/1989 Bowman et al.
 4,932,145 A 6/1990 Reeves
 4,949,481 A 8/1990 Fellner
 4,965,945 A 10/1990 Emrich
 4,980,980 A 1/1991 Schadov et al.
 5,018,283 A 5/1991 Fellner
 5,144,762 A 9/1992 Robinson
 D336,476 S 6/1993 Garman
 D339,592 S 9/1993 Johansson
 D345,364 S 3/1994 Robinson
 D352,044 S 11/1994 Hahn
 5,423,138 A 6/1995 Livesay et al.
 D365,577 S 12/1995 Ruvang
 5,561,925 A 10/1996 Livesay
 D385,286 S 10/1997 Moreno
 5,709,043 A 1/1998 Jones et al.
 D391,583 S 3/1998 Moreno
 D392,292 S 3/1998 Moreno
 D395,661 S 6/1998 Moreno
 5,806,216 A 9/1998 Renski
 D399,511 S 10/1998 Launder et al.
 5,852,888 A 12/1998 Cornelius
 D408,422 S 4/1999 Moreno
 D410,657 S 6/1999 Launder et al.
 D413,338 S 8/1999 Pueyo Molina
 5,937,550 A 8/1999 Emrich
 D414,193 S * 9/1999 Launder D15/29
 D415,173 S 10/1999 Zaun
 5,983,534 A 11/1999 Robinson et al.
 D417,877 S 12/1999 Launder et al.
 6,032,390 A 3/2000 Bierwith
 D429,256 S 8/2000 Zaun
 D429,258 S 8/2000 Zaun
 6,321,471 B2 11/2001 Fernandez Muñoz et al.
 D454,891 S 3/2002 Ketting et al.
 D460,464 S 7/2002 Ketting et al.
 D461,198 S 8/2002 Ketting et al.
 D461,832 S 8/2002 Ketting et al.
 6,477,796 B1 11/2002 Cornelius
 6,735,890 B2 5/2004 Carpenter et al.
 6,745,503 B1 6/2004 Moreno et al.
 6,766,602 B2 7/2004 Cox et al.
 D499,749 S 12/2004 Launder et al.
 6,836,983 B2 1/2005 Moreno et al.
 6,865,828 B1 3/2005 Molino et al.
 6,871,426 B2 3/2005 Keech et al.
 D505,137 S 5/2005 Steinlage et al.
 D512,078 S 11/2005 Poutre
 D527,029 S 8/2006 Launder et al.
 7,100,315 B2 9/2006 Carpenter et al.
 7,168,193 B2 1/2007 Moreno et al.
 D552,632 S 10/2007 De Martiis
 D560,232 S 1/2008 De Martiis
 7,367,144 B2 5/2008 Jones et al.
 D614,206 S 4/2010 Ruvang
 7,739,814 B2 6/2010 Carpenter et al.
 7,762,015 B2 7/2010 Smith et al.
 D624,943 S 10/2010 Gibbon
 8,191,291 B2 6/2012 Vanderpoorten et al.
 D706,307 S 6/2014 Renski et al.
 D706,311 S 6/2014 Renski et al.
 D706,312 S 6/2014 Renski et al.
 D706,839 S 6/2014 Renski et al.
 D706,840 S 6/2014 Renski et al.
 D707,263 S 6/2014 Renski et al.
 D707,264 S 6/2014 Renski et al.
 8,943,717 B2 2/2015 Renski et al.
 D727,367 S 4/2015 Renski et al.
 D727,368 S 4/2015 Renski et al.
 D727,369 S 4/2015 Renski et al.
 D727,979 S 4/2015 Renski et al.
 D727,980 S 4/2015 Renski et al.

D727,981 S 4/2015 Renski et al.
 D727,982 S * 4/2015 Renski D15/28
 D728,635 S 5/2015 Kunz
 D728,636 S * 5/2015 Kunz D15/28
 D728,637 S * 5/2015 Kunz D15/28
 9,057,177 B2 6/2015 Renski et al.
 9,062,436 B2 6/2015 Renski et al.
 9,222,243 B2 12/2015 Cheyne et al.
 D748,681 S 2/2016 Renski et al.
 D748,682 S 2/2016 Renski et al.
 D748,684 S 2/2016 Renski et al.
 D748,685 S 2/2016 Kunz
 D749,146 S 2/2016 Renski et al.
 D749,147 S 2/2016 Kunz
 D761,883 S 7/2016 Kunz
 D769,946 S 10/2016 Kunz
 D774,108 S 12/2016 Balan et al.
 D774,109 S 12/2016 Balan et al.
 D774,110 S 12/2016 Balan et al.
 D774,564 S 12/2016 Balan et al.
 D774,565 S 12/2016 Balan et al.
 D774,566 S 12/2016 Balan et al.
 D774,567 S 12/2016 Balan et al.
 D775,240 S 12/2016 Balan et al.
 D775,241 S 12/2016 Balan et al.
 D775,242 S 12/2016 Balan et al.
 D775,243 S 12/2016 Serrurier et al.
 D775,673 S 1/2017 Balan et al.
 2004/0010949 A1 * 1/2004 Laguarda E02F 9/2858
 37/452
 2008/0028644 A1 * 2/2008 Lopez
 Almendros E02F 9/2825
 37/457
 2012/0131821 A1 * 5/2012 Brufau Guinovart . B2D 19/06
 37/452
 2012/0260540 A1 10/2012 Guimaraes et al.
 2012/0297649 A1 11/2012 Gomar
 2013/0086825 A1 4/2013 Renski et al.
 2013/0185964 A1 * 7/2013 Anisy E02F 9/2825
 37/453
 2013/0333254 A1 * 12/2013 Wallis E02F 9/2825
 37/456
 2014/0173948 A1 6/2014 Ok et al.
 2014/0259806 A1 * 9/2014 Rimmey E02F 9/2891
 37/455
 2014/0259808 A1 * 9/2014 Lahood E02F 9/2841
 37/455
 2014/0352182 A1 12/2014 Lahood et al.
 2015/0167278 A1 * 6/2015 Rivera E02F 9/2875
 37/452
 2016/0083935 A1 3/2016 Edmonds

FOREIGN PATENT DOCUMENTS

CL 1193-1999 9/1999
 CL 223-1999 11/1999
 CL 1457-1999 11/1999
 CL 1583-1999 6/2000
 CL 2671-2005 7/2006
 CL 3115-2005 9/2006
 CL 3116-2005 9/2006
 CL 173-2008 8/2008
 CL 174-2008 8/2008
 CL 2524-2008 1/2009
 CL 1764-2008 7/2009
 CL 618-2010 11/2010
 CL 739-2010 12/2010
 CL 291-2012 11/2012
 EM 000089099-0001-0003 10/2003
 EM 000877477-0001-0009 1/2008
 EM 000895396-0001-0015 3/2008
 EP 0 411 486 A1 2/1991
 EP 1 174 547 B1 8/2006
 EP 2 011 927 A2 1/2009
 GB 1049195 3/1988
 GB 1050103 4/1988
 GB 2010025 4/1990
 GB 2010026 4/1990

(56)

References Cited

FOREIGN PATENT DOCUMENTS

| | | |
|----|-------------------|---------|
| GB | 2057051 | 12/1995 |
| GB | 2057052 | 12/1995 |
| GB | 2057053 | 12/1995 |
| GB | 2060104 | 4/1996 |
| GB | 2060105 | 4/1996 |
| GB | 2057055 | 5/1996 |
| GB | 2091441 | 10/1999 |
| GB | 2091502 | 10/1999 |
| GB | 2095654 | 3/2000 |
| GB | 2097590 | 3/2000 |
| GB | 2097591 | 4/2000 |
| GB | 2097592 | 4/2000 |
| GB | 2097593 | 5/2000 |
| GB | 2104929 | 3/2001 |
| GB | 2106421 | 4/2001 |
| WO | WO 2015/165505 A1 | 11/2015 |

OTHER PUBLICATIONS

Caterpillar Inc., "Cat Backhoe Loader Options," published Jan. 1, 2005.

U.S. Appl. No. 14/824,655, filed Aug. 12, 2015. (Unpublished).

U.S. Appl. No. 14/824,749, filed Aug. 12, 2015. (Unpublished).

- U.S. Appl. No. 29/580,224, filed Oct. 6, 2016. (Unpublished).
- U.S. Appl. No. 29/579,884, filed Oct. 4, 2016. (Unpublished).
- U.S. Appl. No. 29/580,075, filed Oct. 5, 2016. (Unpublished).
- U.S. Appl. No. 29/580,340, filed Oct. 7, 2016. (Unpublished).
- U.S. Appl. No. 29/580,338, filed Oct. 7, 2016. (Unpublished).
- U.S. Appl. No. 29/580,305, filed Oct. 7, 2016. (Unpublished).
- U.S. Appl. No. 29/580,327, filed Oct. 7, 2016. (Unpublished).
- U.S. Appl. No. 29/580,314, filed Oct. 7, 2016. (Unpublished).
- U.S. Appl. No. 29/587,746, filed Dec. 15, 2016. (Unpublished).
- U.S. Appl. No. 29/587,749, filed Dec. 15, 2016. (Unpublished).
- U.S. Appl. No. 29/587,739, filed Dec. 15, 2016. (Unpublished).
- U.S. Appl. No. 29/587,750, filed Dec. 15, 2016. (Unpublished).
- U.S. Appl. No. 29/587,757, filed Dec. 15, 2016. (Unpublished).
- U.S. Appl. No. 29/587,754, filed Dec. 15, 2016. (Unpublished).
- U.S. Appl. No. 29/587,762, filed Dec. 15, 2016. (Unpublished).
- U.S. Appl. No. 29/587,759, filed Dec. 15, 2016. (Unpublished).
- U.S. Appl. No. 29/587,758, filed Dec. 15, 2016. (Unpublished).
- U.S. Appl. No. 29/587,765, filed Dec. 15, 2016. (Unpublished).
- U.S. Appl. No. 29/587,767, filed Dec. 15, 2016. (Unpublished).
- U.S. Appl. No. 29/587,779, filed Dec. 15, 2016. (Unpublished).
- U.S. Appl. No. 29/587,776, filed Dec. 15, 2016. (Unpublished).
- U.S. Appl. No. 29/587,783, filed Dec. 15, 2016. (Unpublished).
- U.S. Appl. No. 29/587,785, filed Dec. 15, 2016. (Unpublished).
- U.S. Appl. No. 29/587,744, filed Dec. 15, 2016. (Unpublished).

* cited by examiner

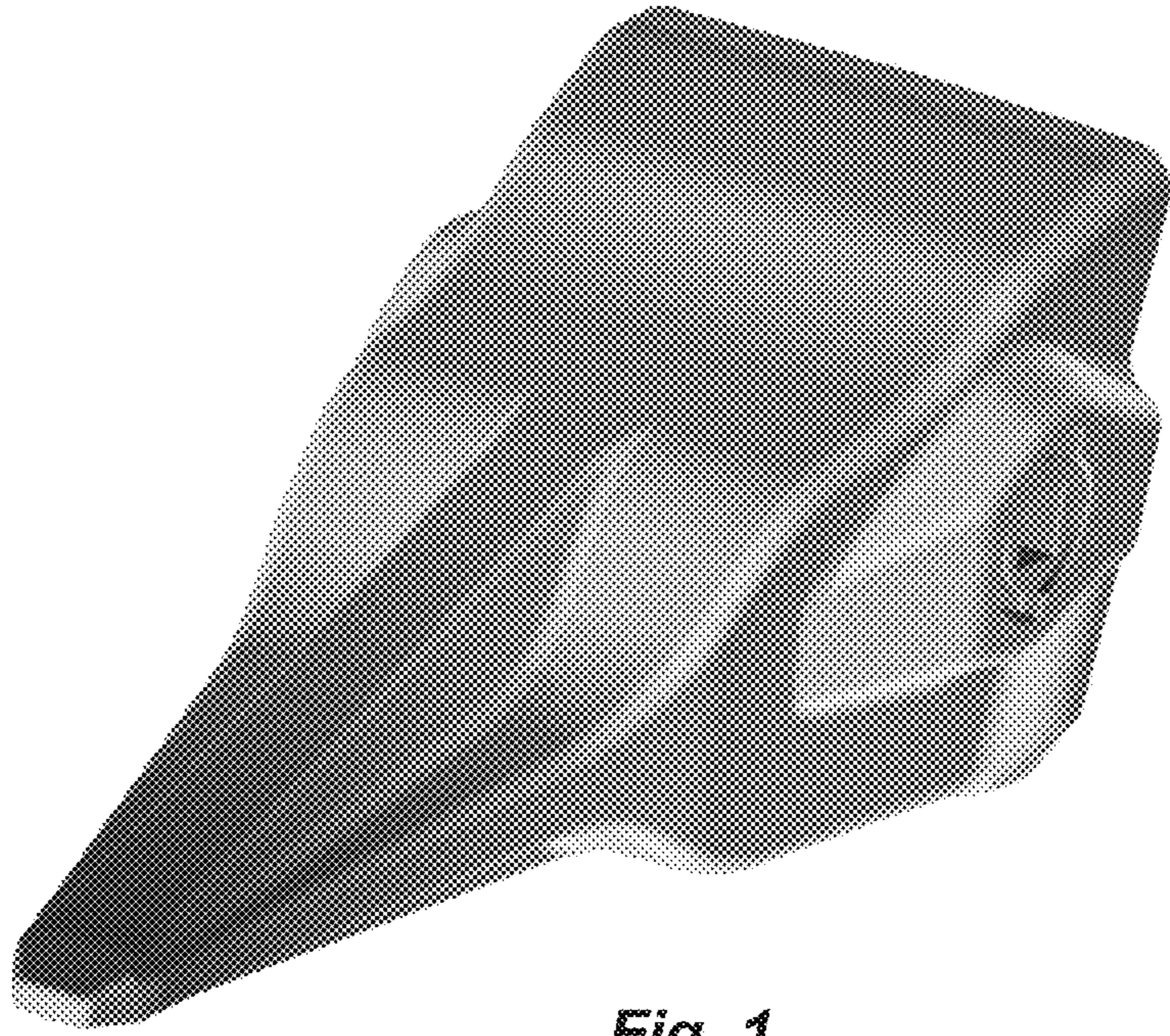

Fig. 1

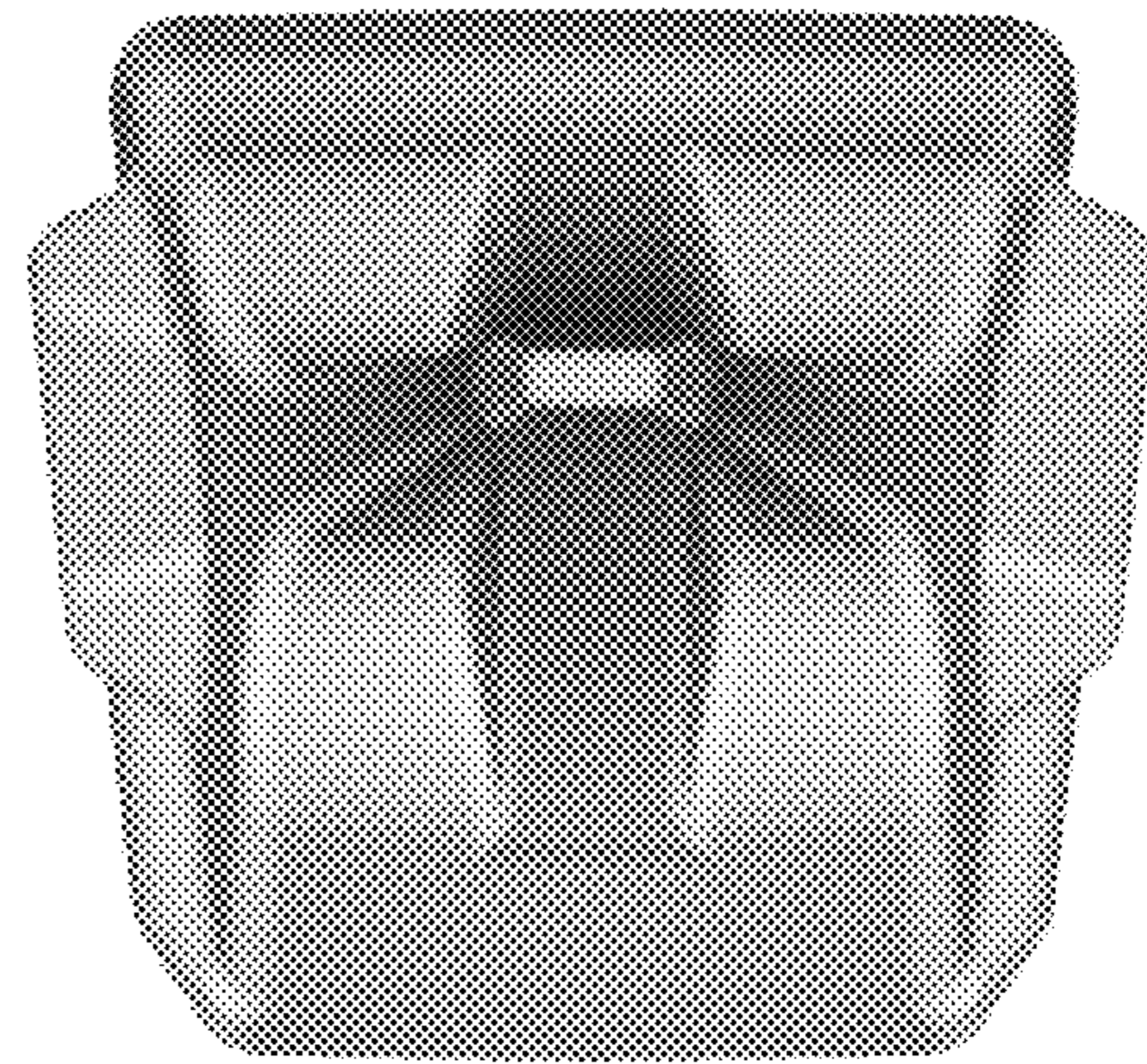

Fig. 2

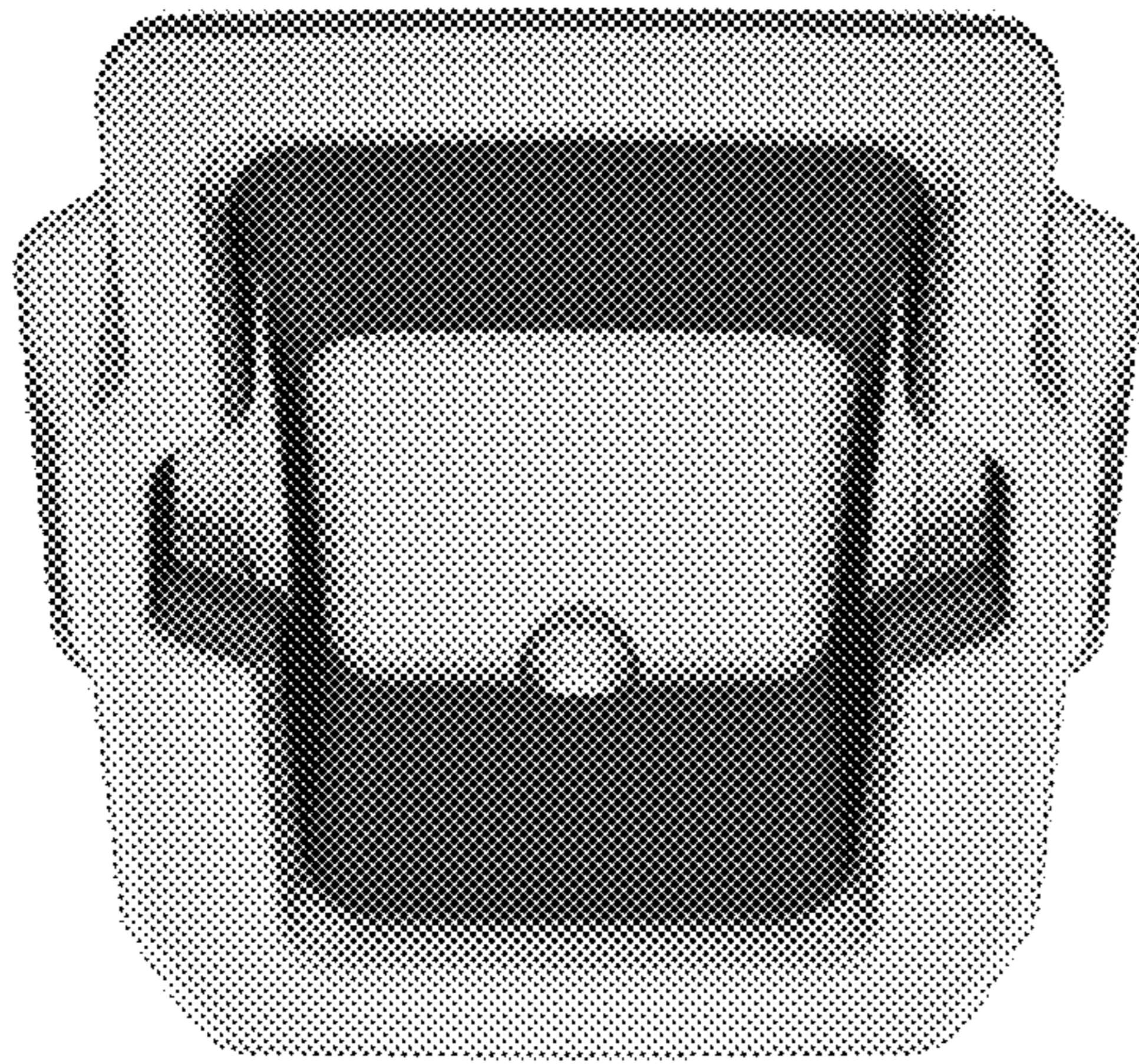

Fig. 3

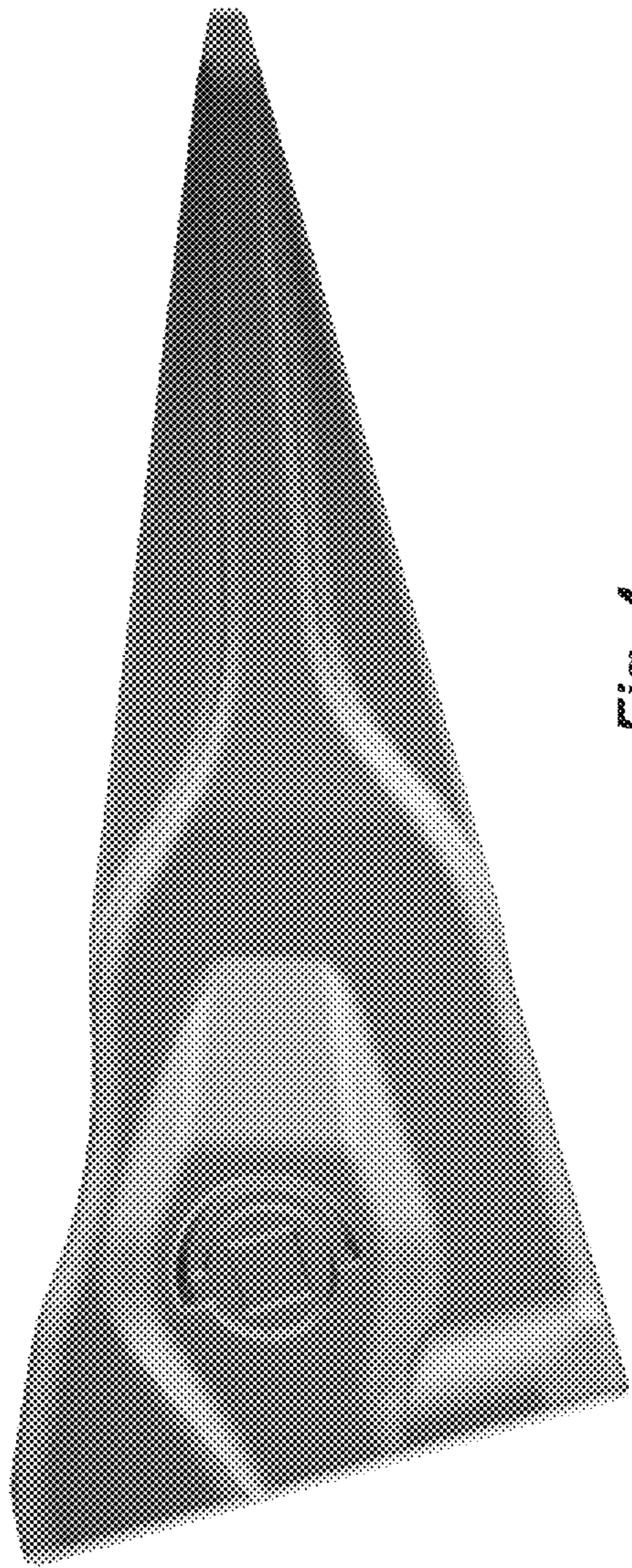

Fig. 4

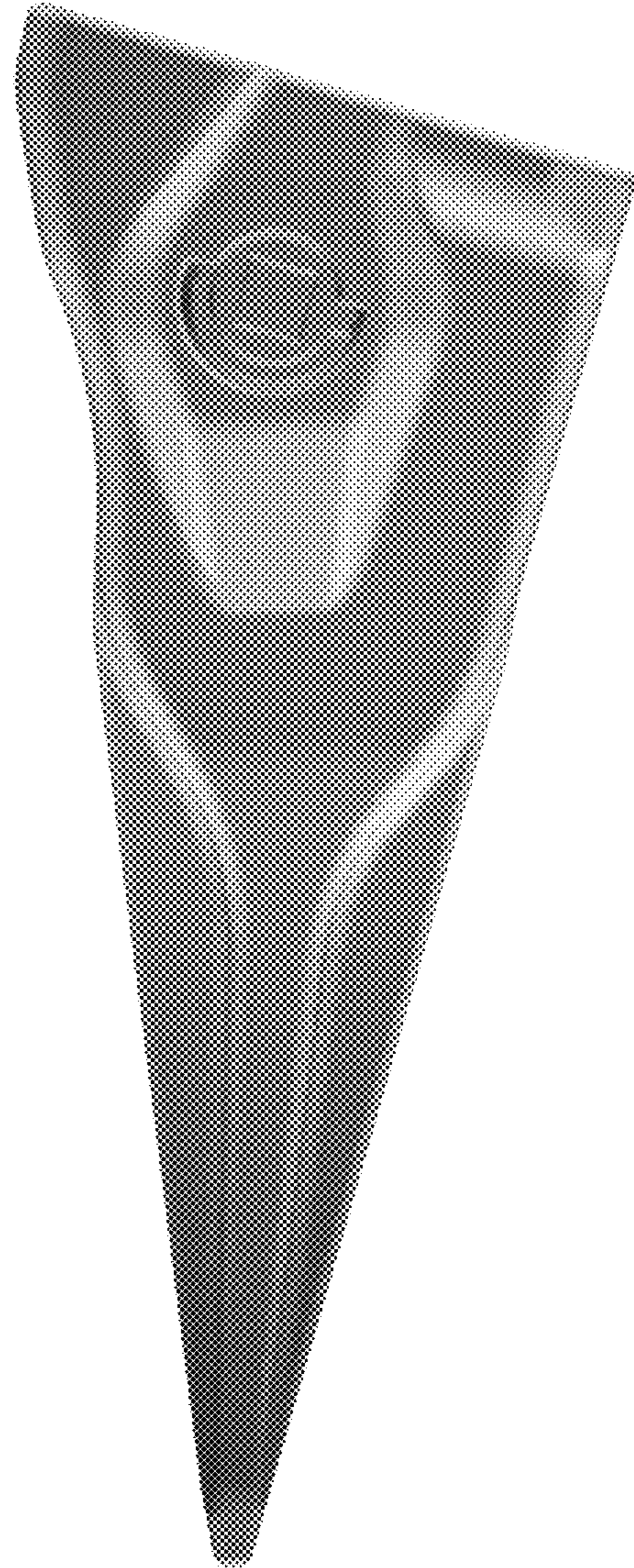

Fig. 5

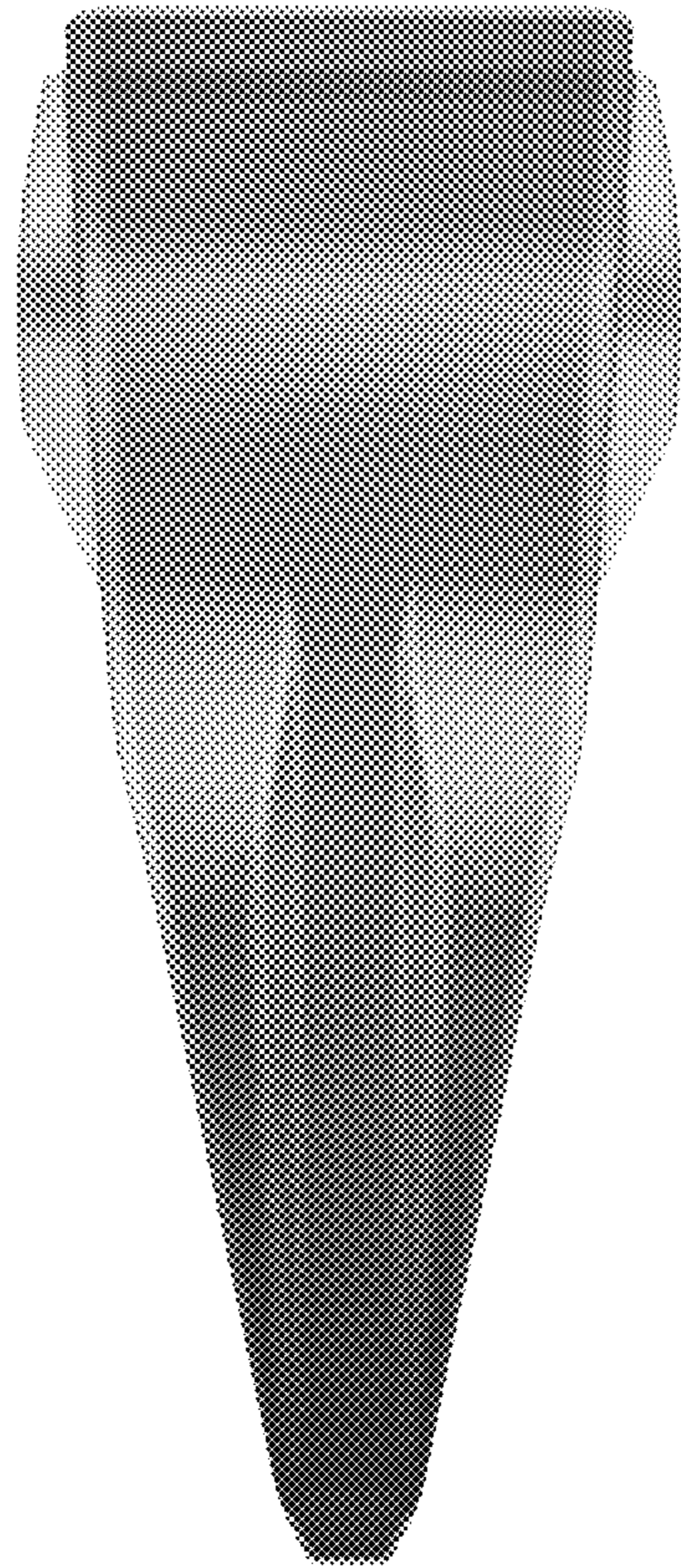

Fig. 6

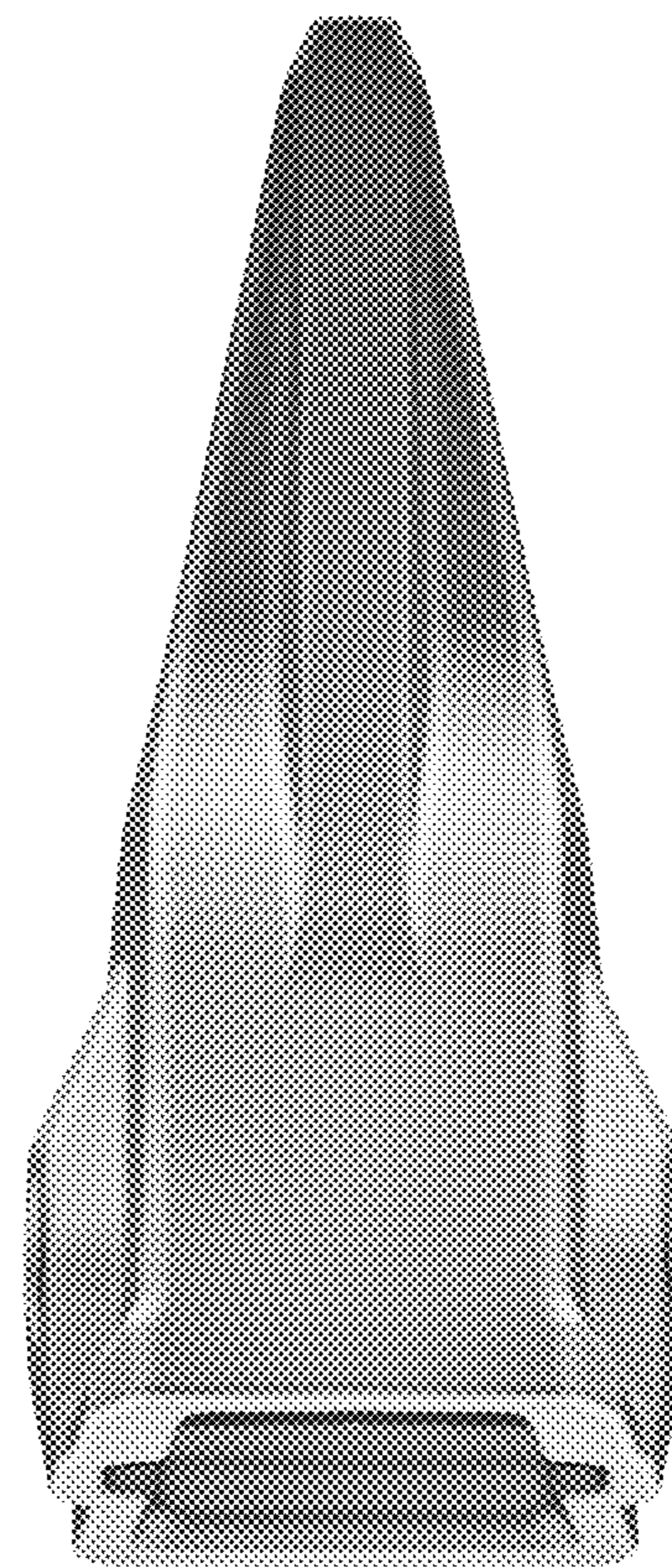

Fig. 7