



US00D803725S

(12) **United States Design Patent**  
**Suzuki**

(10) **Patent No.:** **US D803,725 S**

(45) **Date of Patent:** **\*\* Nov. 28, 2017**

(54) **AUTOMOBILE**

(71) Applicant: **HONDA MOTOR CO., LTD.**, Tokyo  
(JP)

(72) Inventor: **Takahiro Suzuki**, Wako (JP)

(73) Assignee: **HONDA MOTOR CO., LTD.**, Tokyo  
(JP)

(\*\*) Term: **15 Years**

(21) Appl. No.: **29/573,018**

(22) Filed: **Aug. 2, 2016**

(30) **Foreign Application Priority Data**

Feb. 4, 2016 (JP) ..... 2016-002328

(51) **LOC (10) Cl.** ..... **12-08**

(52) **U.S. Cl.**  
USPC ..... **D12/91**

(58) **Field of Classification Search**  
USPC ..... D12/90-92, 164, 169, 196;  
296/181.1-181.5; D21/548, 560  
CPC ..... B60Y 2306/01; B60K 11/085  
See application file for complete search history.

(56) **References Cited**

**U.S. PATENT DOCUMENTS**

D505,359 S \* 5/2005 Suzuki ..... D12/91  
D512,000 S \* 11/2005 Suzuki ..... D12/91

D626,040 S \* 10/2010 Sakae ..... D12/164  
D626,886 S \* 11/2010 Sakae ..... D12/91  
D651,942 S \* 1/2012 Cho ..... D12/91  
D689,795 S \* 9/2013 Takei ..... D12/91  
D731,923 S \* 6/2015 Tanaka ..... D12/91  
D765,545 S \* 9/2016 Oh ..... D12/91  
D779,378 S \* 2/2017 Kim ..... D12/91  
D780,065 S \* 2/2017 Suzuki ..... D12/91  
D781,181 S \* 3/2017 Giolito ..... D12/91  
D784,857 S \* 4/2017 Ishii ..... D12/91  
D788,644 S \* 6/2017 Mueller ..... D12/91

\* cited by examiner

*Primary Examiner* — John Windmuller

*Assistant Examiner* — Melvin L Davis

(74) *Attorney, Agent, or Firm* — Westerman, Hattori,  
Daniels & Adrian, LLP

(57) **CLAIM**

The design for an automobile, as shown and described.

**DESCRIPTION**

FIG. 1 is a front left side perspective view of an automobile;  
FIG. 2 is a rear left side perspective view thereof;  
FIG. 3 is a left side view thereof;  
FIG. 4 is a right side view thereof;  
FIG. 5 is a front view thereof;  
FIG. 6 is a rear view thereof; and,  
FIG. 7 is a top plan view thereof.  
The broken lines in the drawings illustrate portions of the  
automobile that forms no part of the claimed design.

**1 Claim, 7 Drawing Sheets**

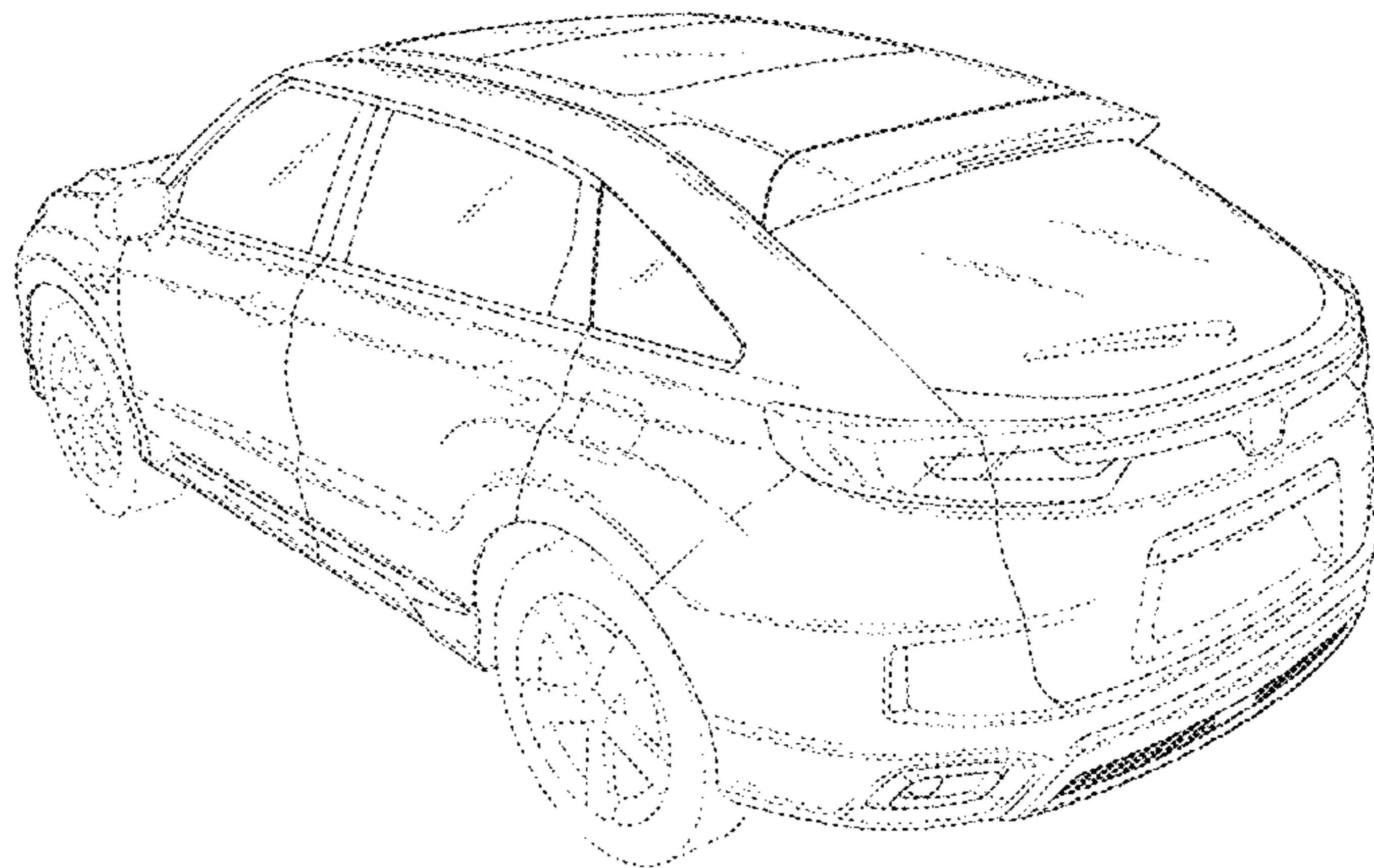
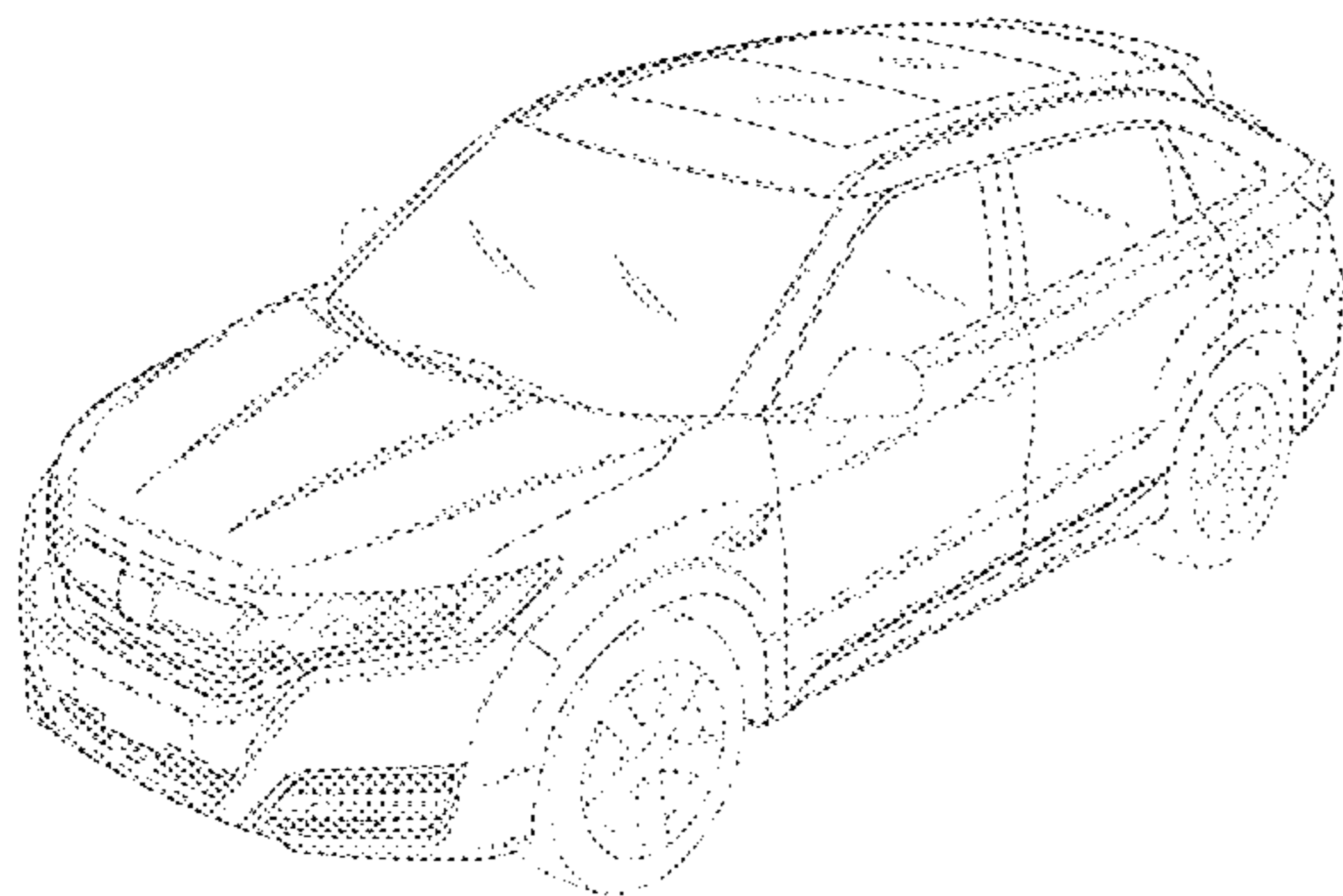

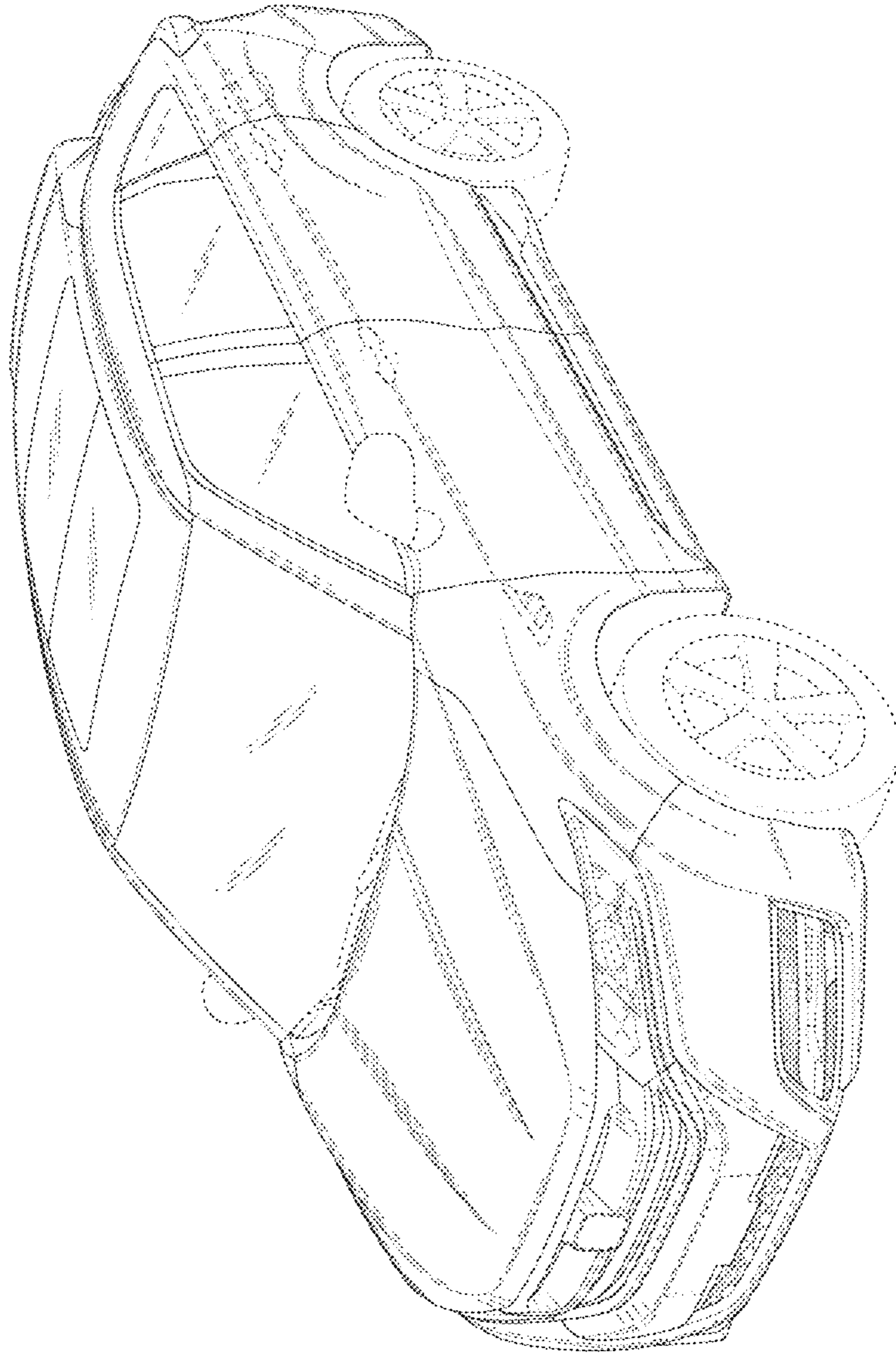

FIG.1

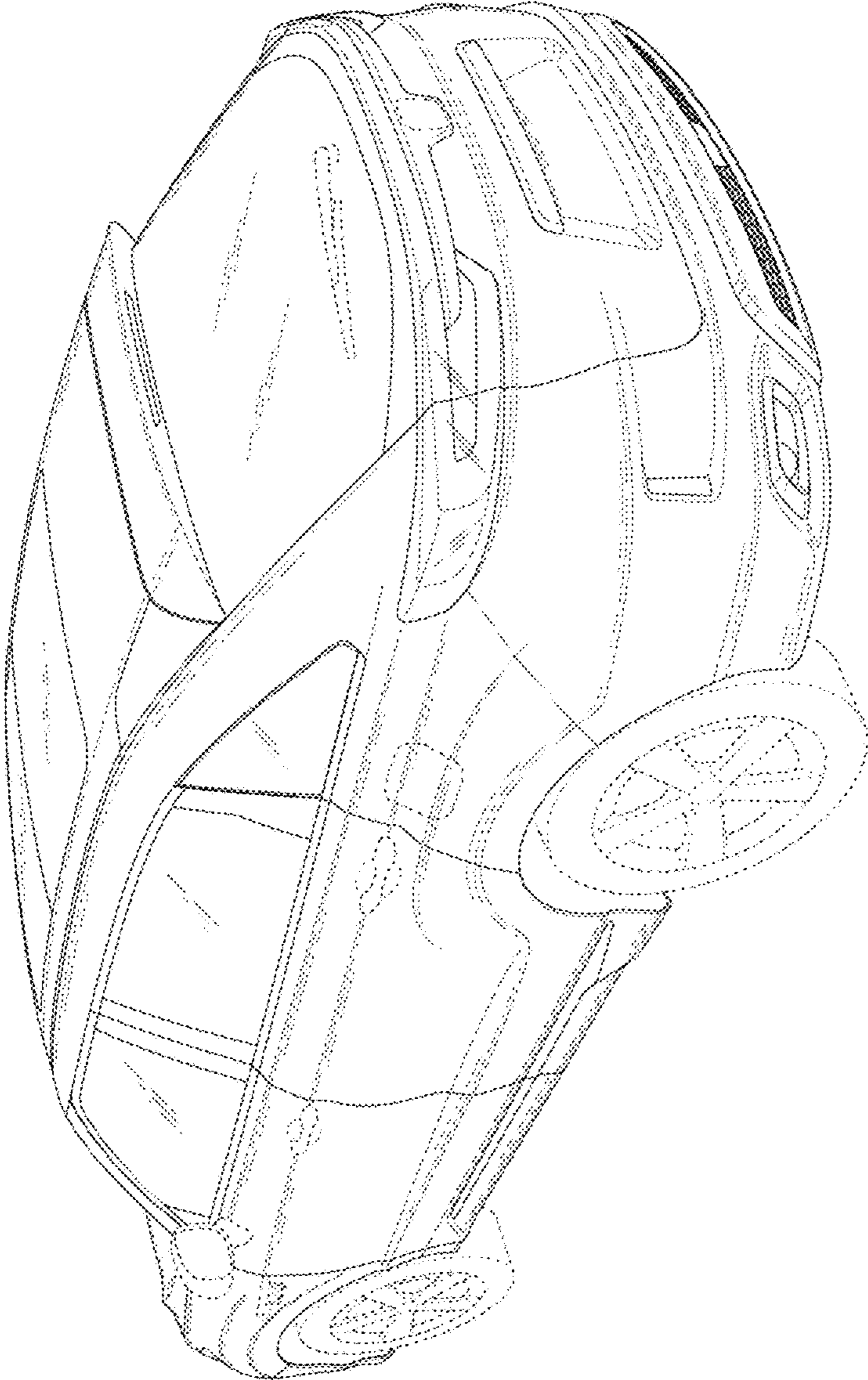

FIG.2



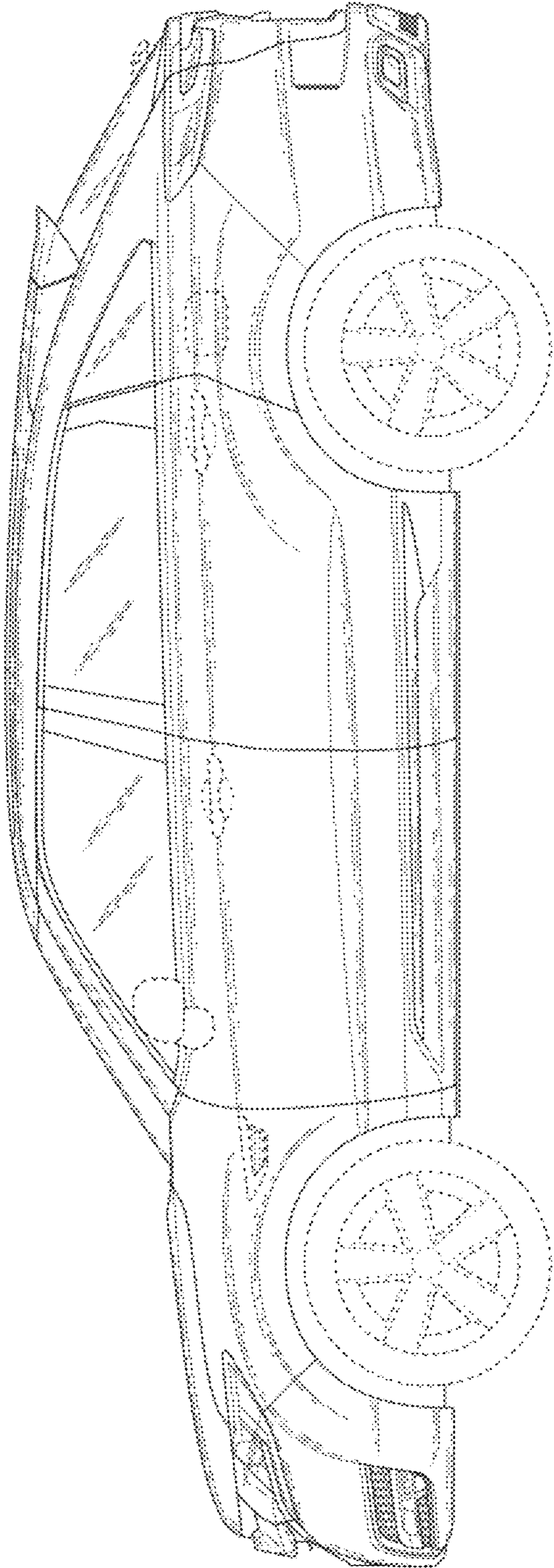

FIG.3

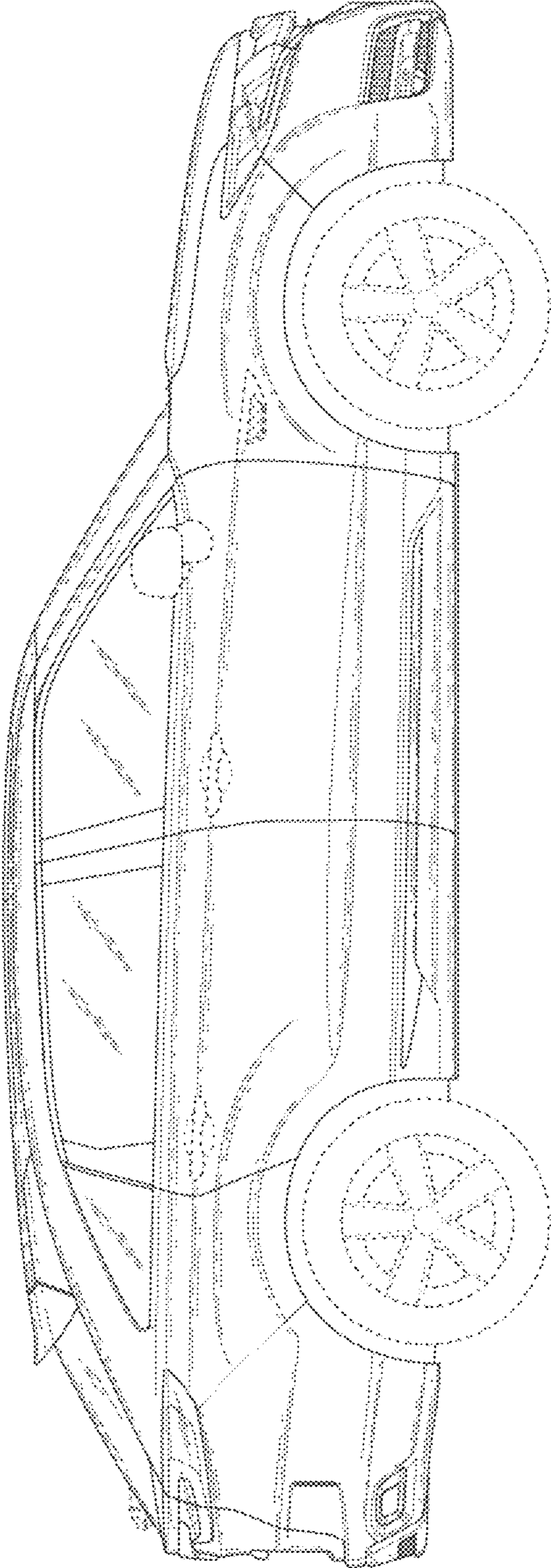

FIG.4

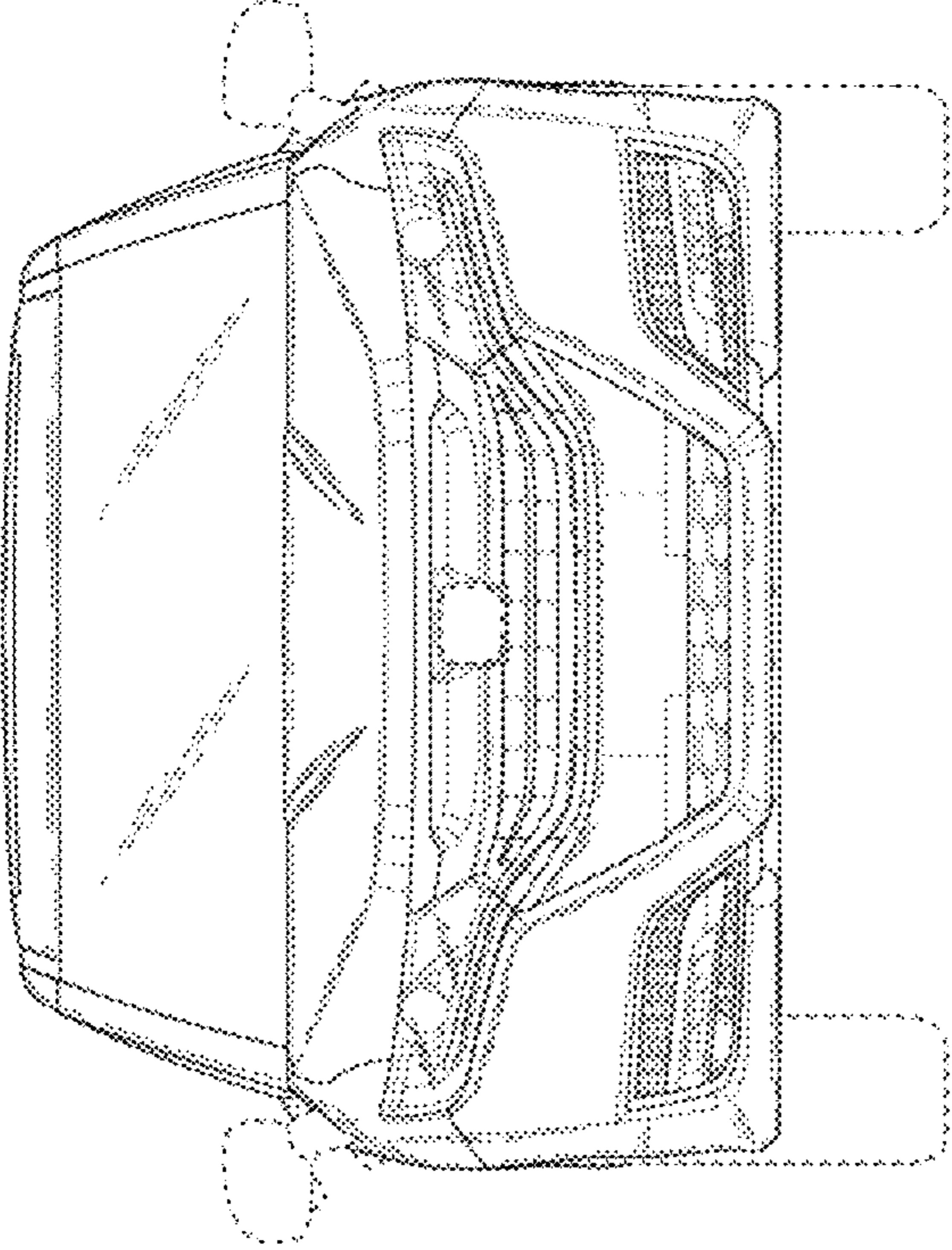

FIG.5

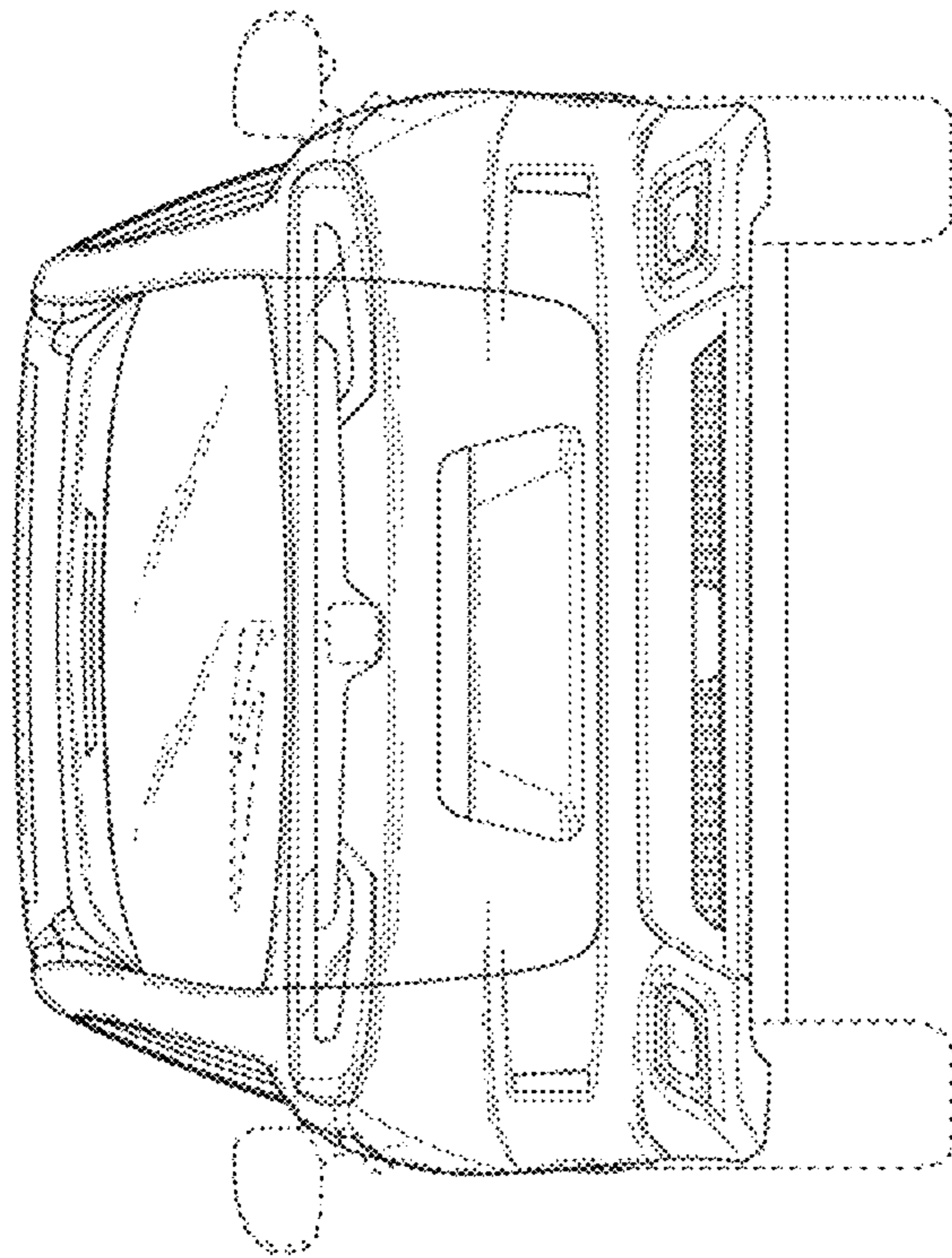

FIG.6



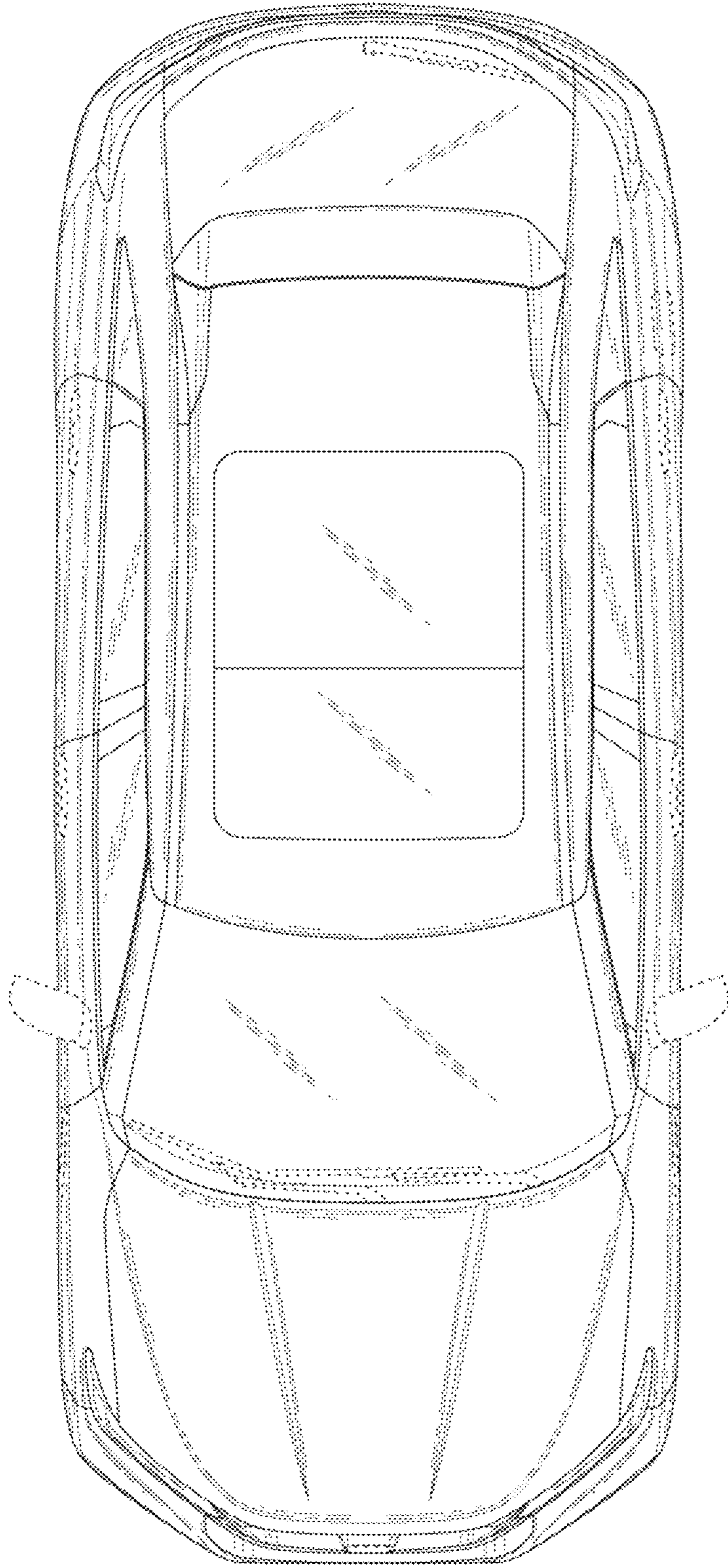

FIG.7