



US00D803108S

(12) **United States Design Patent**
Liu

(10) **Patent No.:** **US D803,108 S**
(45) **Date of Patent:** **** Nov. 21, 2017**

(54) **BIKE TRAILER CONNECTOR**

(71) Applicant: **Cheh-Kang Liu**, Taipei (TW)

(72) Inventor: **Cheh-Kang Liu**, Taipei (TW)

(**) Term: **15 Years**

(21) Appl. No.: **29/578,363**

(22) Filed: **Sep. 21, 2016**

(51) **LOC (10) Cl.** **12-16**

(52) **U.S. Cl.**
USPC **D12/162**

(58) **Field of Classification Search**
USPC D12/159, 160, 161, 162, 203, 223, 400;
D8/349, 363, 373, 382, 394, 396
CPC . B60D 1/065; B60D 1/00; B60D 1/60; B60D
1/06
See application file for complete search history.

(56) **References Cited**

U.S. PATENT DOCUMENTS

5,109,931	A *	5/1992	Goll	B60D 1/07 172/248
D415,986	S *	11/1999	Stech	D12/162
6,755,589	B2 *	6/2004	Friesen	A01B 59/042 280/494
6,764,092	B1 *	7/2004	Greaves, Jr.	B60D 1/00 280/402
D526,252	S *	8/2006	Lambros	D12/162
D526,602	S *	8/2006	Sparkes	D12/162
D554,029	S *	10/2007	Roll	D12/162
D609,139	S *	2/2010	Luckey	D12/162
D615,006	S *	5/2010	Goodman	D12/162
D695,652	S *	12/2013	In	D12/162
D737,734	S *	9/2015	McGinnes	D12/162
2002/0140206	A1 *	10/2002	Lloyd	B60D 1/04 280/491.5
2008/0252042	A1 *	10/2008	Sparkes	B60D 1/00 280/491.3

OTHER PUBLICATIONS

Amazon.com. "Tag Along Spare Hitch Bracket Ammaco TR90B." First reviewed Jun. 16, 2016. Retrieved Jun. 2, 2017. (<https://www.amazon.co.uk/d/BikesCyclingEquipment/ALONGSPAREHITCHBRACKETAMMACOTRAILEROTHERS/B00J5NLG3S>).*

* cited by examiner

Primary Examiner — Karen S Acker

Assistant Examiner — Jerry Shiuan-Hua Hsu

(74) *Attorney, Agent, or Firm* — Jackson IPG PLLC;
Demian K. Jackson

(57) **CLAIM**

The ornamental design for bike trailer connector, as shown and described.

DESCRIPTION

FIG. 1 is a perspective view of a bike trailer connector showing my new design;

FIG. 2 is a front elevational view thereof;

FIG. 3 is a rear elevational view thereof;

FIG. 4 is a left side elevational view thereof;

FIG. 5 is a right side elevational view thereof;

FIG. 6 is a top plan view thereof;

FIG. 7 is a bottom plan view thereof; and,

FIG. 8 is a front elevational view of the bike trailer connector of FIG. 1 shown in a position of use with an unclaimed bike trailer.

The broken lines illustrating holes, nuts, and bolts in the figures depict portions of the bike trailer connector that form no part of the claimed design. The remaining broken lines in FIG. 8 illustrate environmental matter that forms no part of the claimed design.

1 Claim, 7 Drawing Sheets

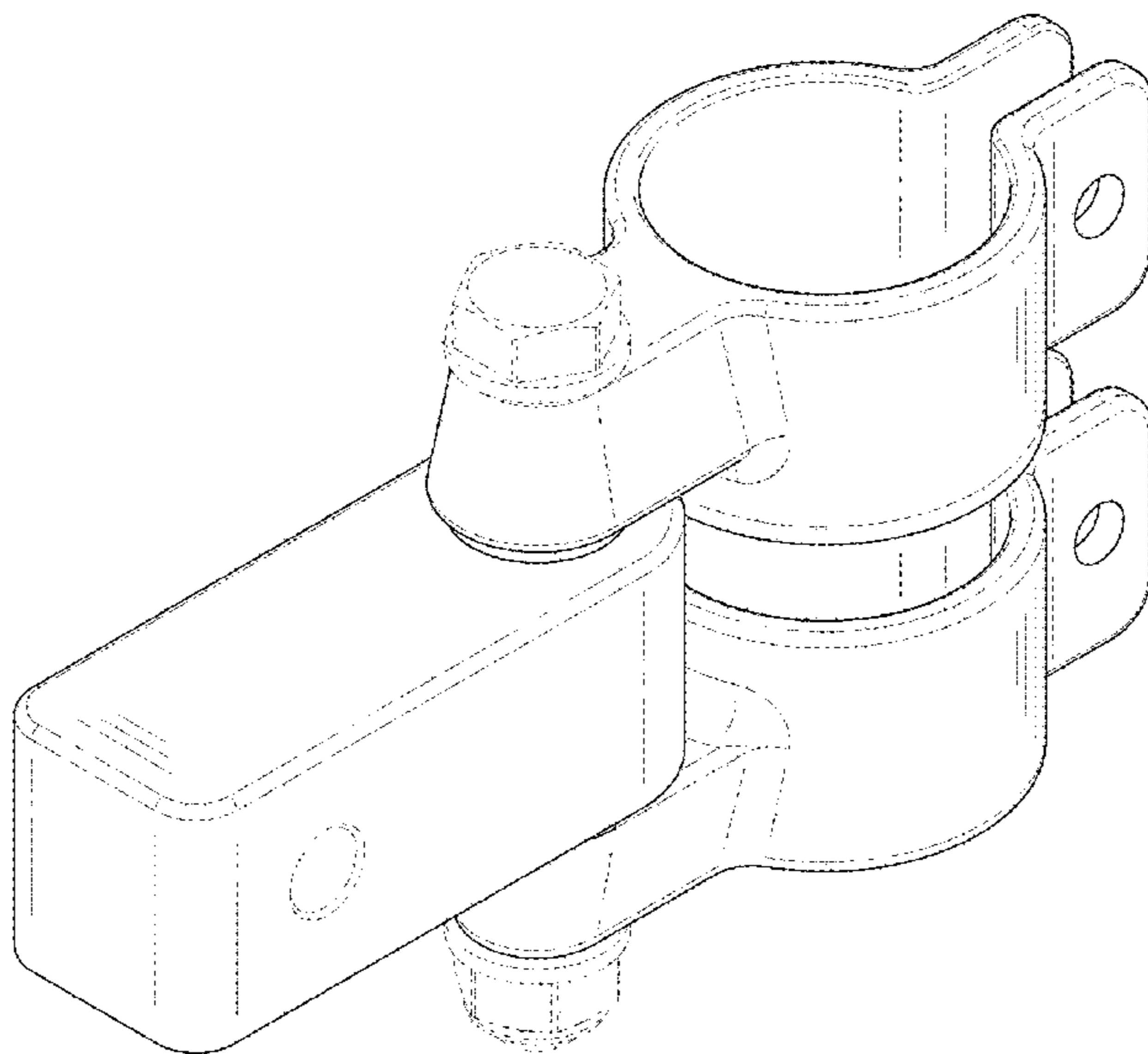

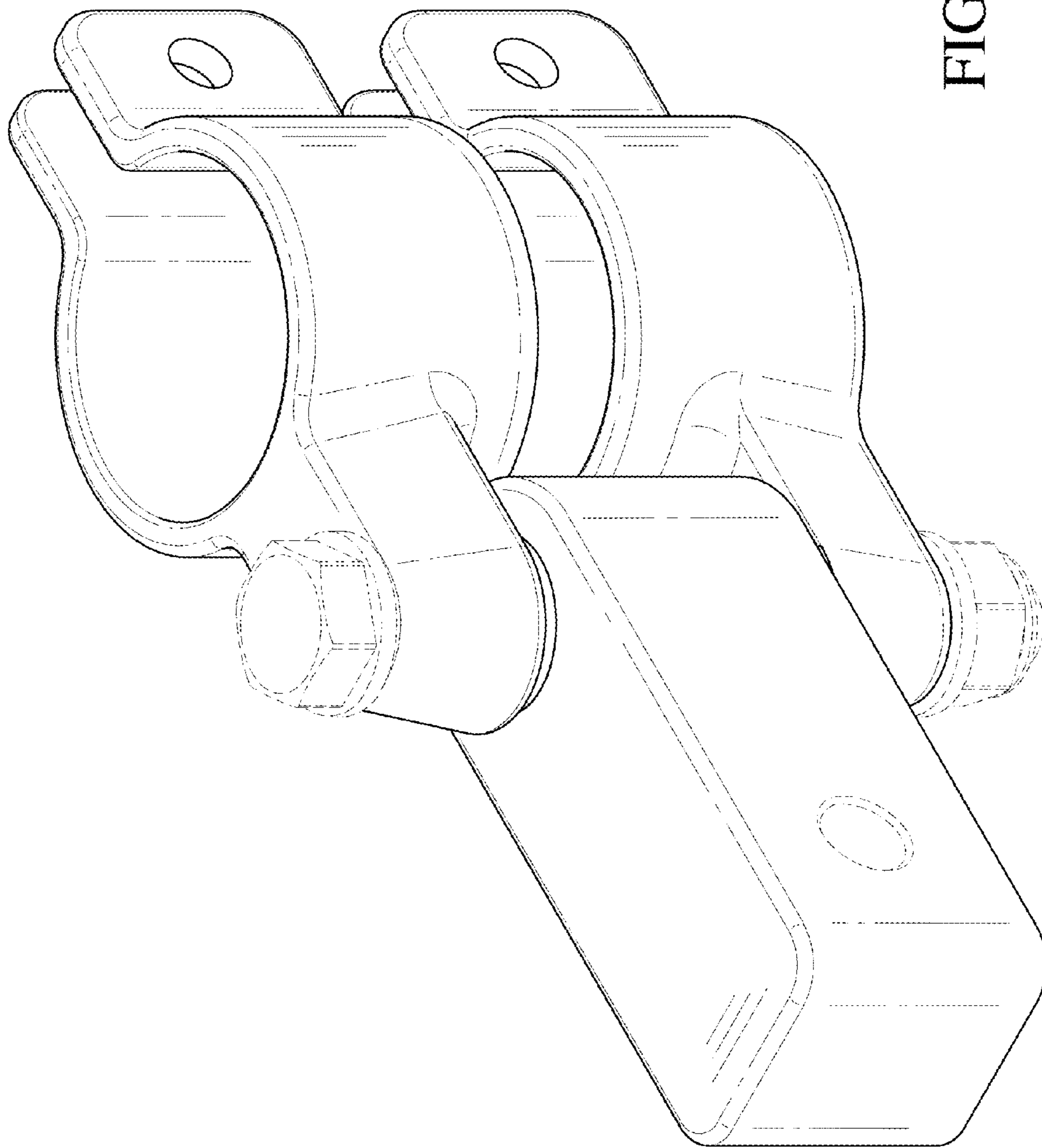

FIG. 1

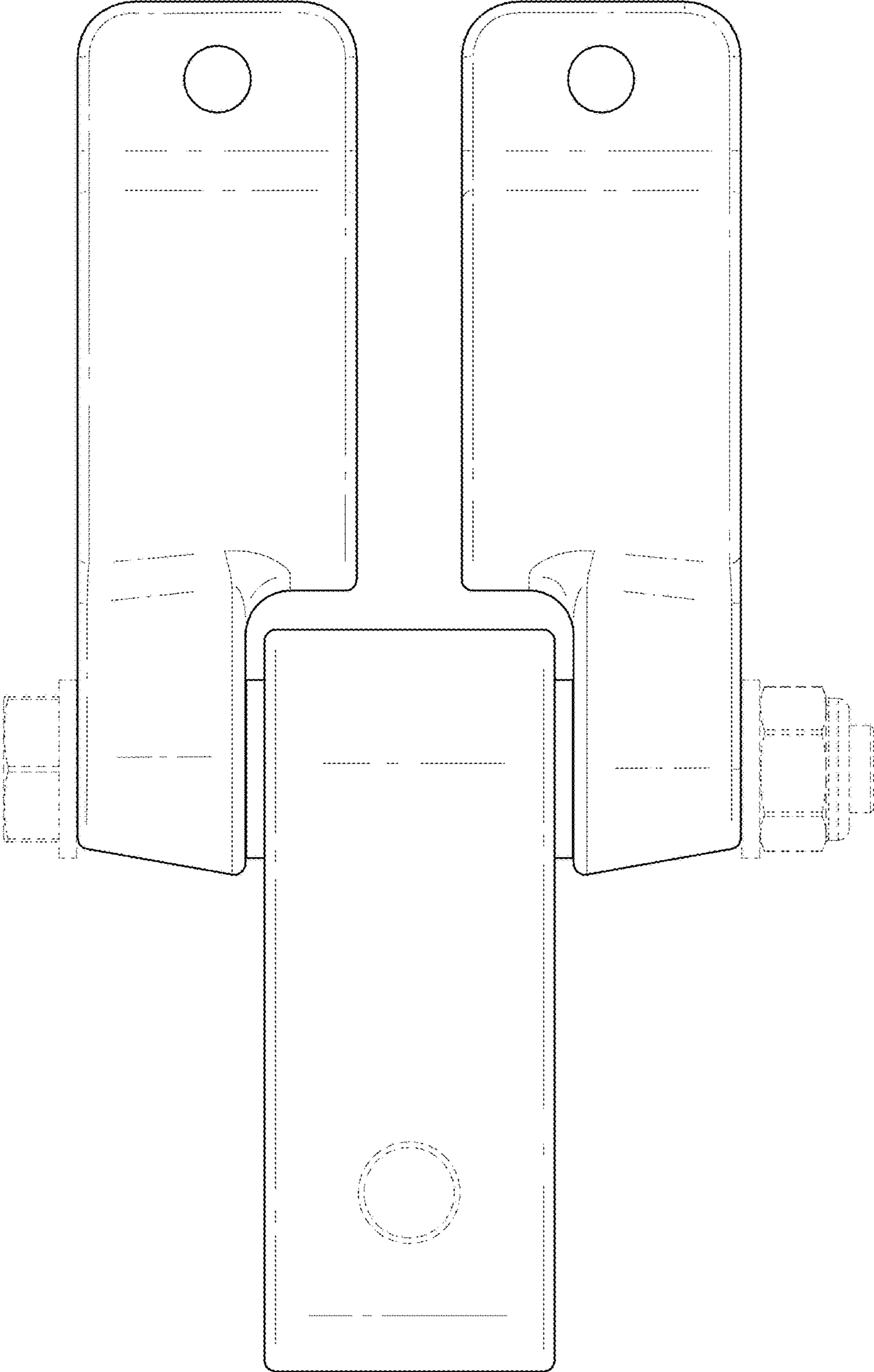

FIG. 2

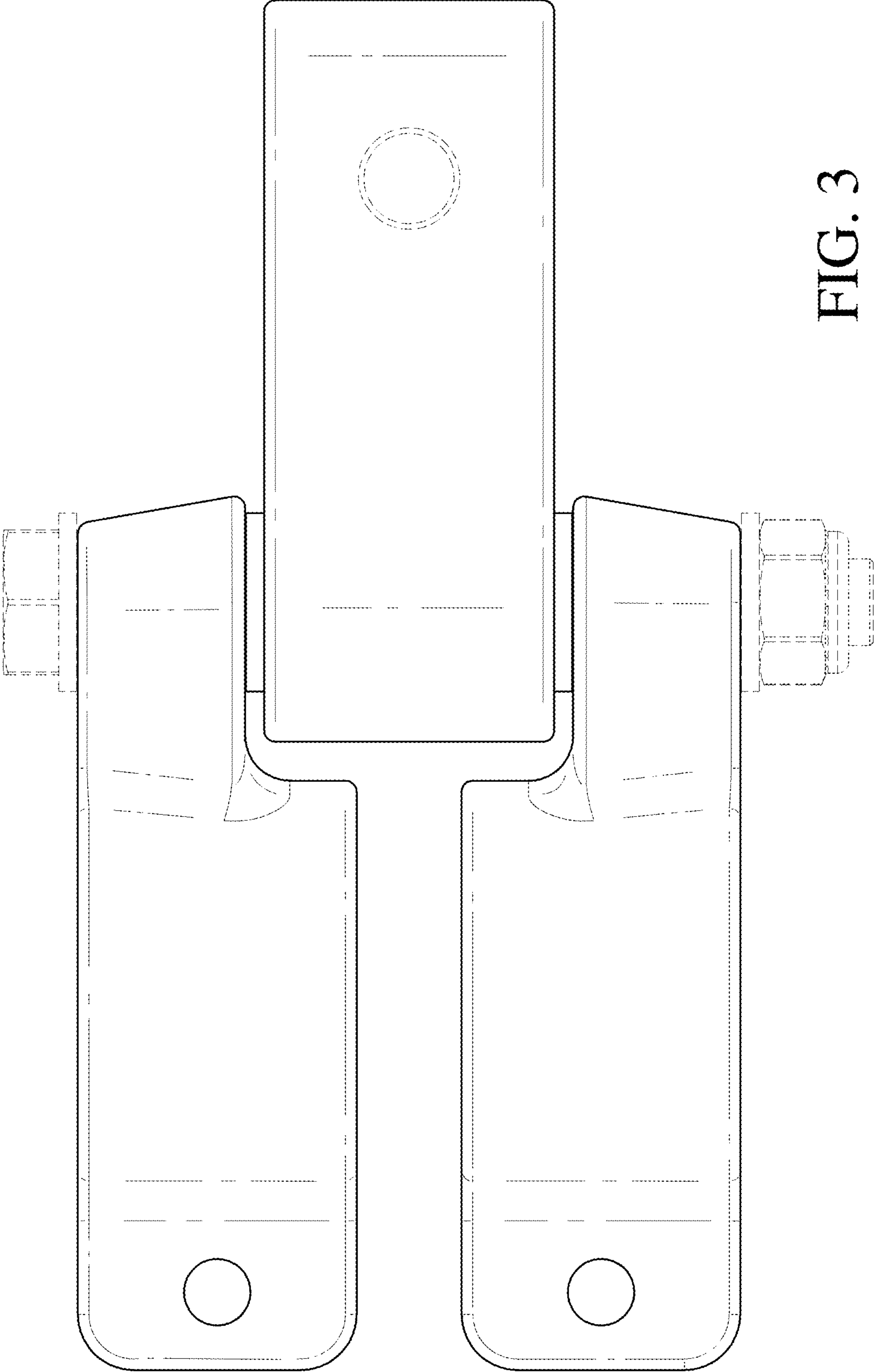

FIG. 3

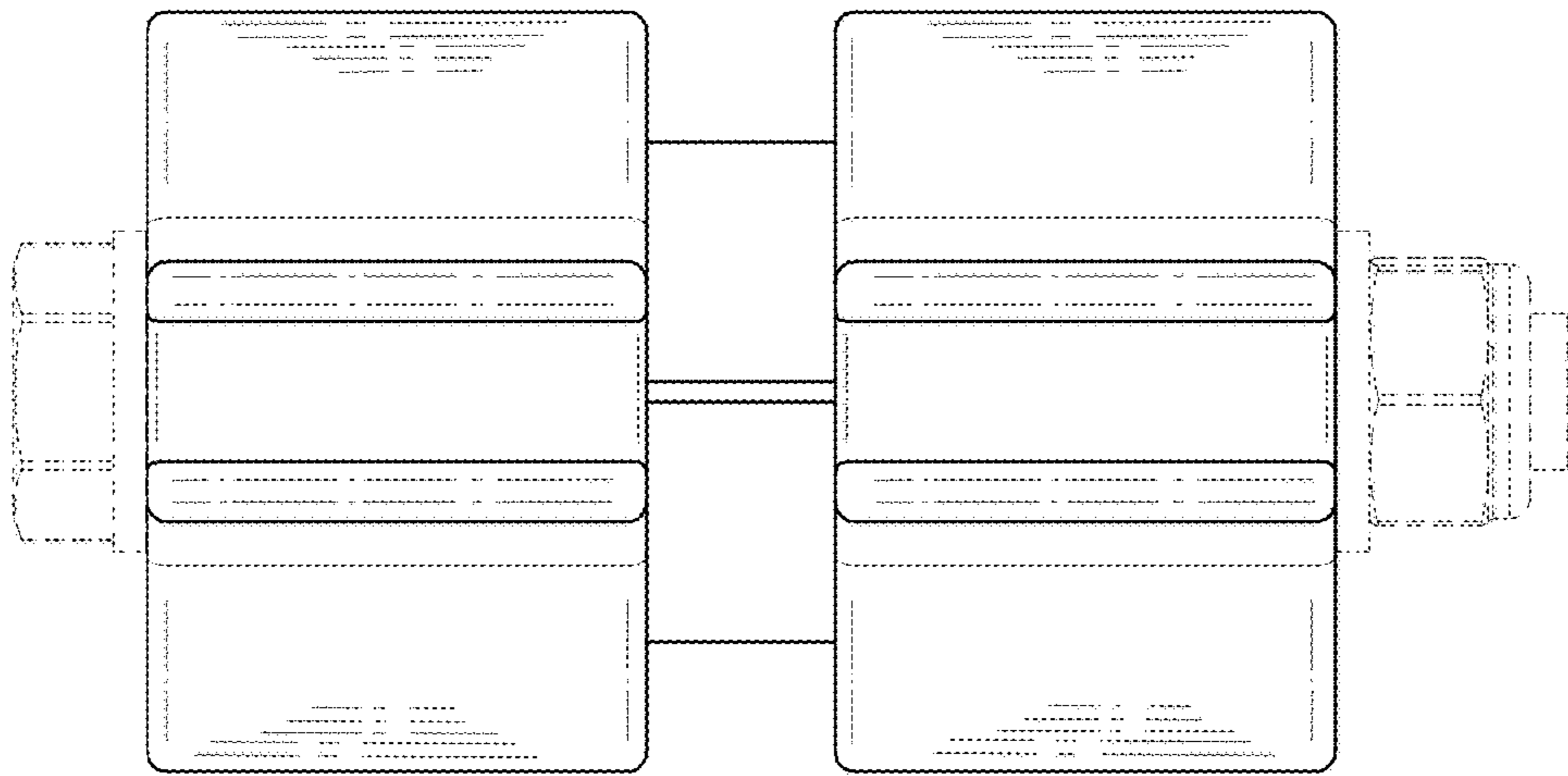

FIG. 5

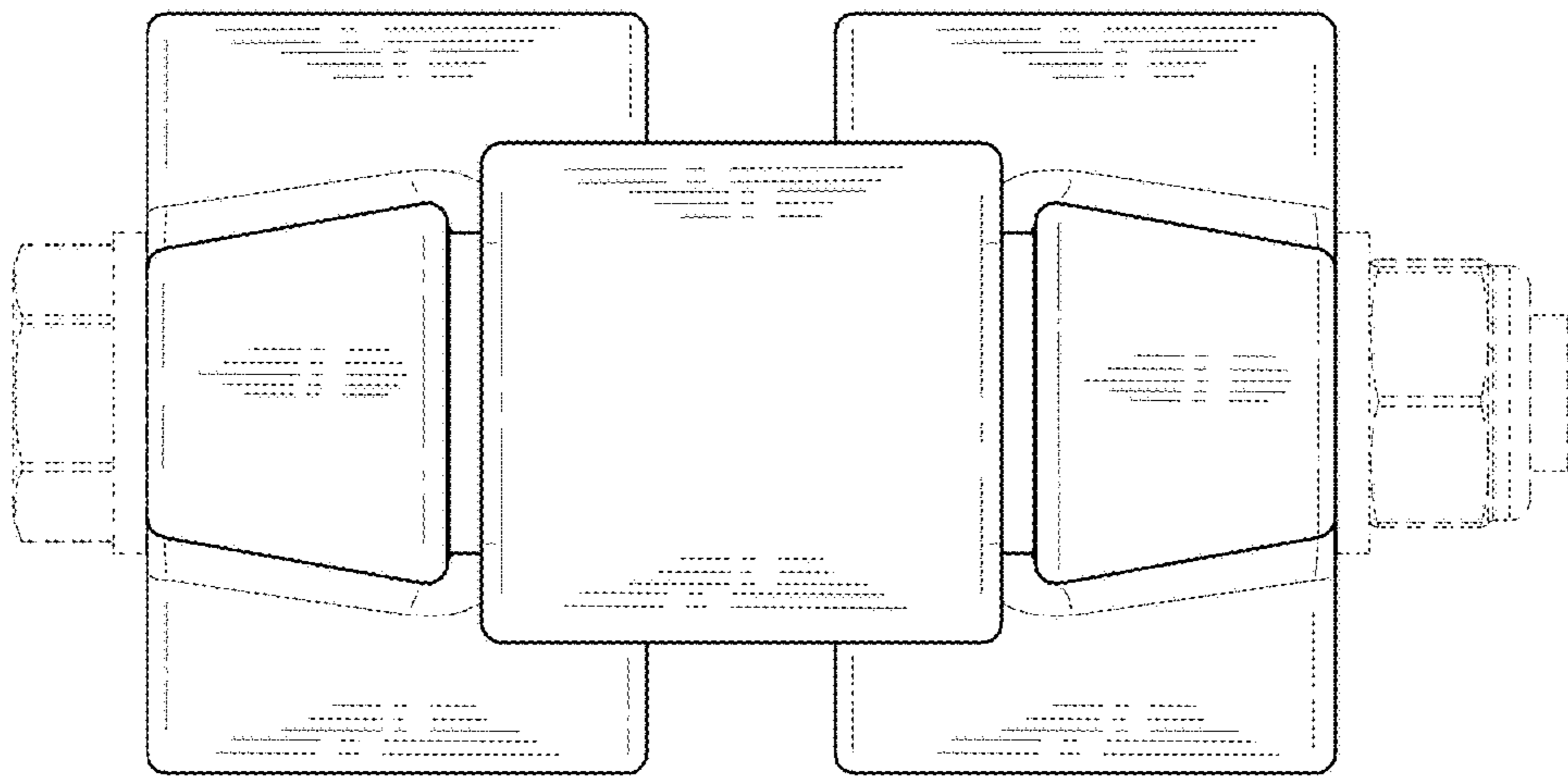

FIG. 4

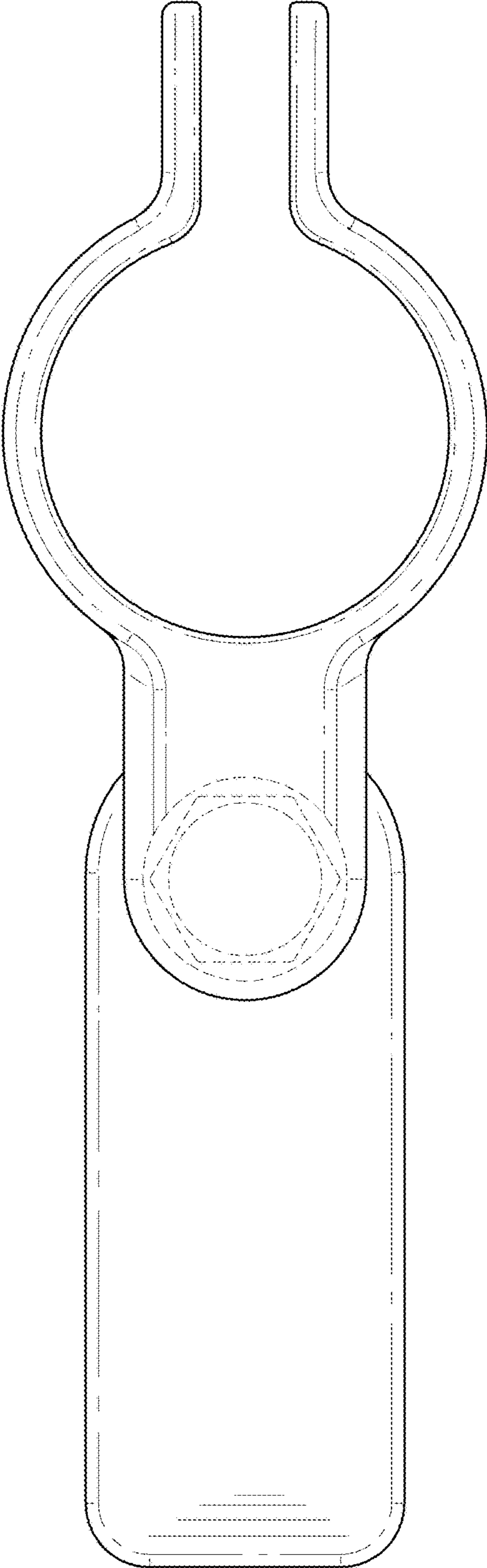

FIG. 6

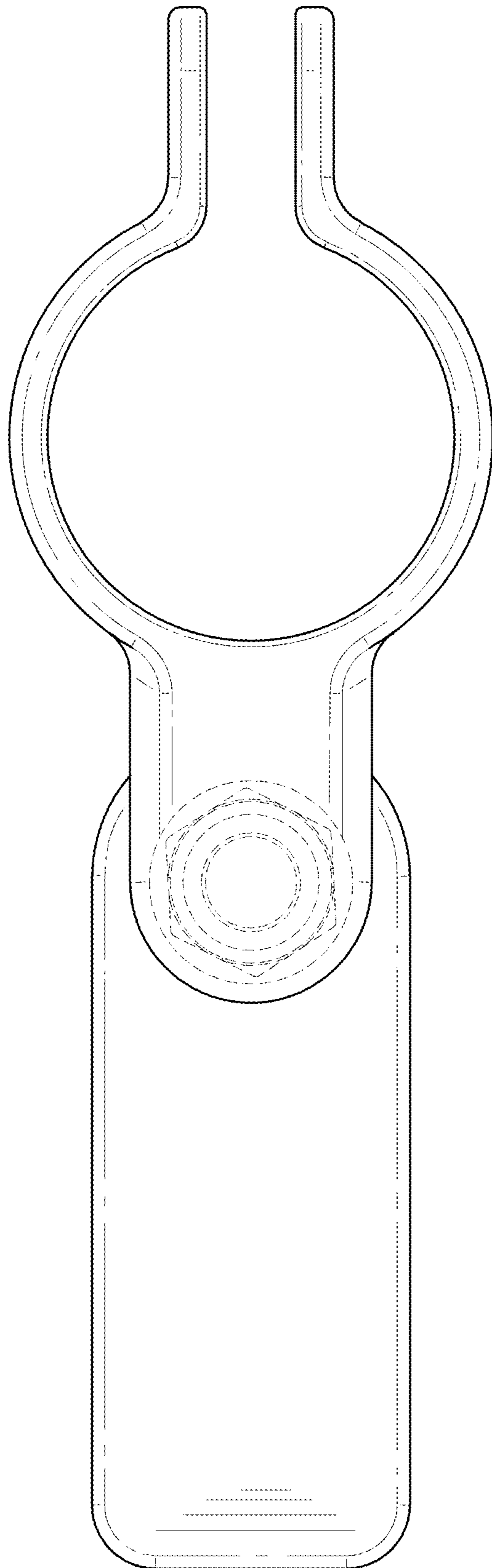

FIG. 7

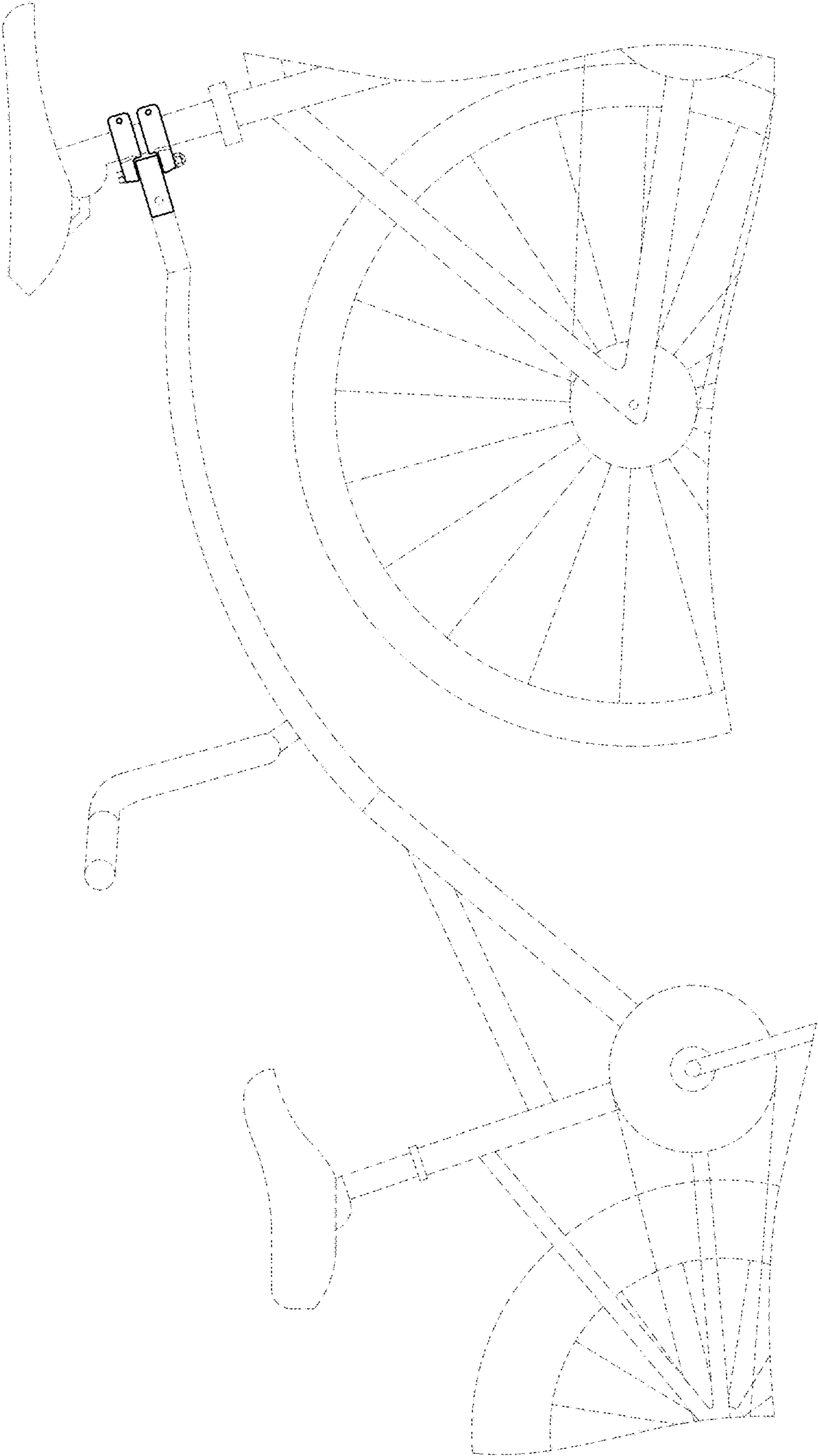

FIG. 8