



US00D803098S

(12) **United States Design Patent** (10) **Patent No.:** **US D803,098 S**
Lee (45) **Date of Patent:** **** Nov. 21, 2017**

(54) **AERIAL VEHICLE**

(74) *Attorney, Agent, or Firm* — Fenwick & West LLP

(71) Applicant: **GoPro, Inc.**, San Mateo, CA (US)

(57) **CLAIM**

(72) Inventor: **Seung Heon Lee**, Cupertino, CA (US)

The ornamental design for an aerial vehicle, as shown and described.

(73) Assignee: **GoPro, Inc.**, San Mateo, CA (US)

DESCRIPTION

(**) Term: **15 Years**

(21) Appl. No.: **29/578,014**

(22) Filed: **Sep. 16, 2016**

Related U.S. Application Data

(63) Continuation of application No. 29/535,225, filed on Aug. 4, 2015, now Pat. No. Des. 768,539.

(51) **LOC (10) Cl.** **12-07**

(52) **U.S. Cl.**

USPC **D12/16.1; D21/441**

(58) **Field of Classification Search**

USPC D12/16.1, 319–345; D21/436, 438, 440, D21/442, 443, 446–451, 453, 441

(Continued)

(56) **References Cited**

U.S. PATENT DOCUMENTS

D189,462 S 12/1960 Vogt
D197,038 S 12/1963 Howard

(Continued)

OTHER PUBLICATIONS

Office Action for Canadian Patent Application No. CA 169042, dated Jan. 12, 2017, 5 Pages.

(Continued)

Primary Examiner — Robert M Spear

Assistant Examiner — Marissa J Cash

FIG. 1 is a front, top and left side perspective view of the aerial vehicle with folded propeller arms, folded landing gear, and without propellers;

FIG. 2 is a rear, top and right side perspective view of the aerial vehicle with folded propeller arms, folded landing gear, and without propellers;

FIG. 3 is a front, bottom and right side perspective view of the aerial vehicle with folded propeller arms, folded landing gear, and without propellers;

FIG. 4 is a rear, bottom and left side perspective view of the aerial vehicle with folded propeller arms, folded landing gear, and without propellers;

FIG. 5 is a front elevational view of the aerial vehicle with folded propeller arms, folded landing gear, and without propellers;

FIG. 6 is a rear elevational view of the aerial vehicle with folded propeller arms, folded landing gear, and without propellers;

FIG. 7 is a left side elevational view of the aerial vehicle with folded propeller arms, folded landing gear, and without propellers;

FIG. 8 is a right side elevational view of the aerial vehicle with folded propeller arms, folded landing gear, and without propellers;

FIG. 9 is a top plan view of the aerial vehicle with folded propeller arms, folded landing gear, and without propellers;

FIG. 10 is a bottom plan view of the aerial vehicle with folded propeller arms, folded landing gear, and without propellers.

FIG. 11 is a front, top and left side perspective view of an aerial vehicle;

FIG. 12 is a rear, top and right side perspective view of the aerial vehicle;

FIG. 13 is a front, bottom and right side perspective view of the aerial vehicle;

(Continued)

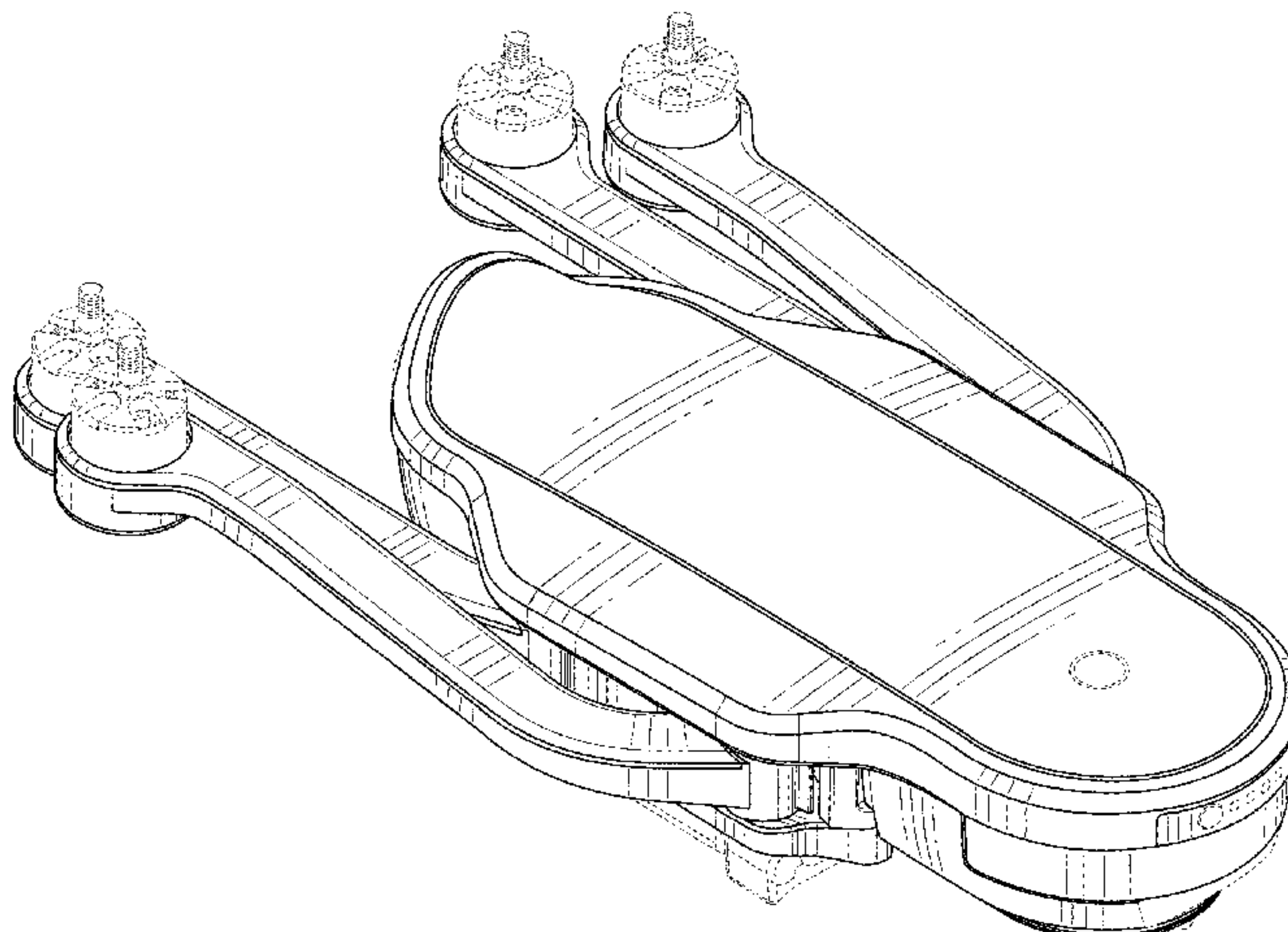

FIG. 14 is a rear, bottom and left side perspective view of the aerial vehicle;
 FIG. 15 is a front elevational view of the aerial vehicle;
 FIG. 16 is a rear elevational view of the aerial vehicle;
 FIG. 17 is a left side elevational view of the aerial vehicle;
 FIG. 18 is a right side elevational view of the aerial vehicle;
 FIG. 19 is a top plan view of the aerial vehicle; and,
 FIG. 20 is a bottom plan view of the aerial vehicle.
 The broken lines in the drawings showing portions of the aerial vehicle are included for the purpose of illustrating environmental structure and form no part of the claimed design.

1 Claim, 20 Drawing Sheets

(58) **Field of Classification Search**

CPC . B64C 39/024; B64C 27/32; B64C 2201/024;
 B64C 27/12; B64C 39/00; B64C 27/08
 See application file for complete search history.

(56) **References Cited**

U.S. PATENT DOCUMENTS

D465,196 S	11/2002	Dammar
D628,658 S	12/2010	Wurm
8,292,215 B2	10/2012	Olm et al.
D691,514 S	10/2013	Wang et al.
D710,452 S	8/2014	Barajas et al.
D710,453 S	8/2014	Barajas et al.
D710,454 S	8/2014	Barajas et al.

8,967,029 B1	3/2015	Calvert	
8,973,861 B2	3/2015	Zhou et al.	
9,061,763 B1	6/2015	Christensen et al.	
9,099,902 B2	8/2015	Chen	
D741,751 S	10/2015	Klaptocz et al.	
D741,779 S	10/2015	Hsiao et al.	
D768,539 S	10/2016	Lee	
9,501,061 B2 *	11/2016	Canoy	G05D 1/0816
2011/0001001 A1	1/2011	Bryant	
2014/0263823 A1	9/2014	Wang et al.	
2014/0339355 A1	11/2014	Olm et al.	
2015/0051755 A1	2/2015	Erhart et al.	
2015/0060606 A1	3/2015	Wang et al.	
2015/0129711 A1	5/2015	Caubel	
2015/0210388 A1	7/2015	Criado et al.	
2015/0259066 A1	9/2015	Johannesson et al.	
2015/0321755 A1	11/2015	Martin et al.	
2015/0336670 A1	11/2015	Zhang	
2016/0001879 A1	1/2016	Johannesson et al.	
2016/0031275 A1	2/2016	Monroe et al.	
2016/0068261 A1	3/2016	Niederberger	
2017/0001721 A1	1/2017	Saika et al.	
2017/0036771 A1	2/2017	Woodman et al.	

OTHER PUBLICATIONS

Office Action for Russian Design Application No. RU 2016502372, dated Mar. 10, 2017, 4 Pages (With English Translation).
 Office Action for U.S. Appl. No. 15/331,707, filed Jun. 5, 2017, 10 Pages.
 Dronepro.org, "Best Drone for GoPro," Date Unknown, four pages. [Online] [Retrieved Apr. 27, 2016] Retrieved from the internet <<http://dronepro.org/>>.

* cited by examiner

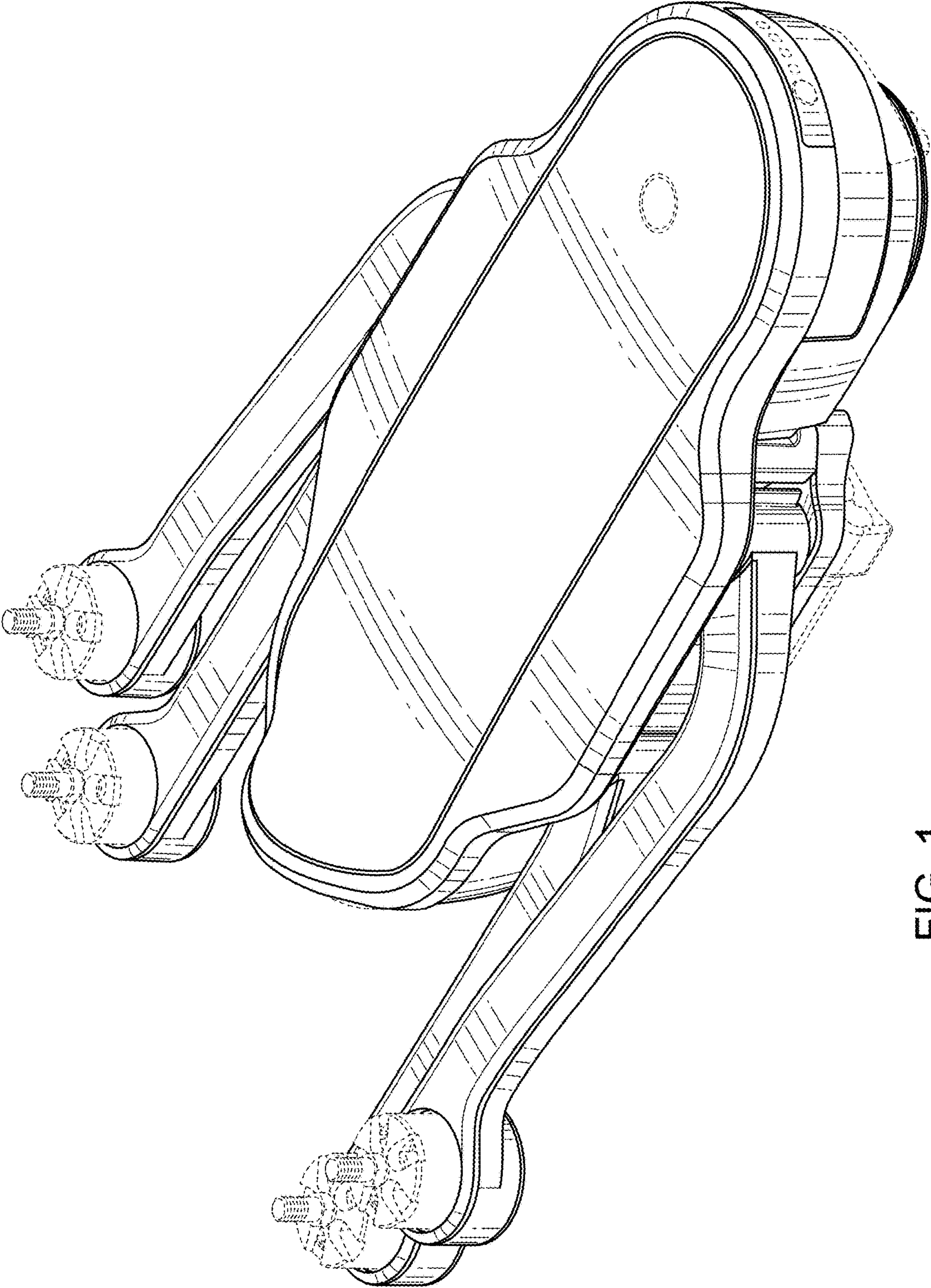

FIG. 1

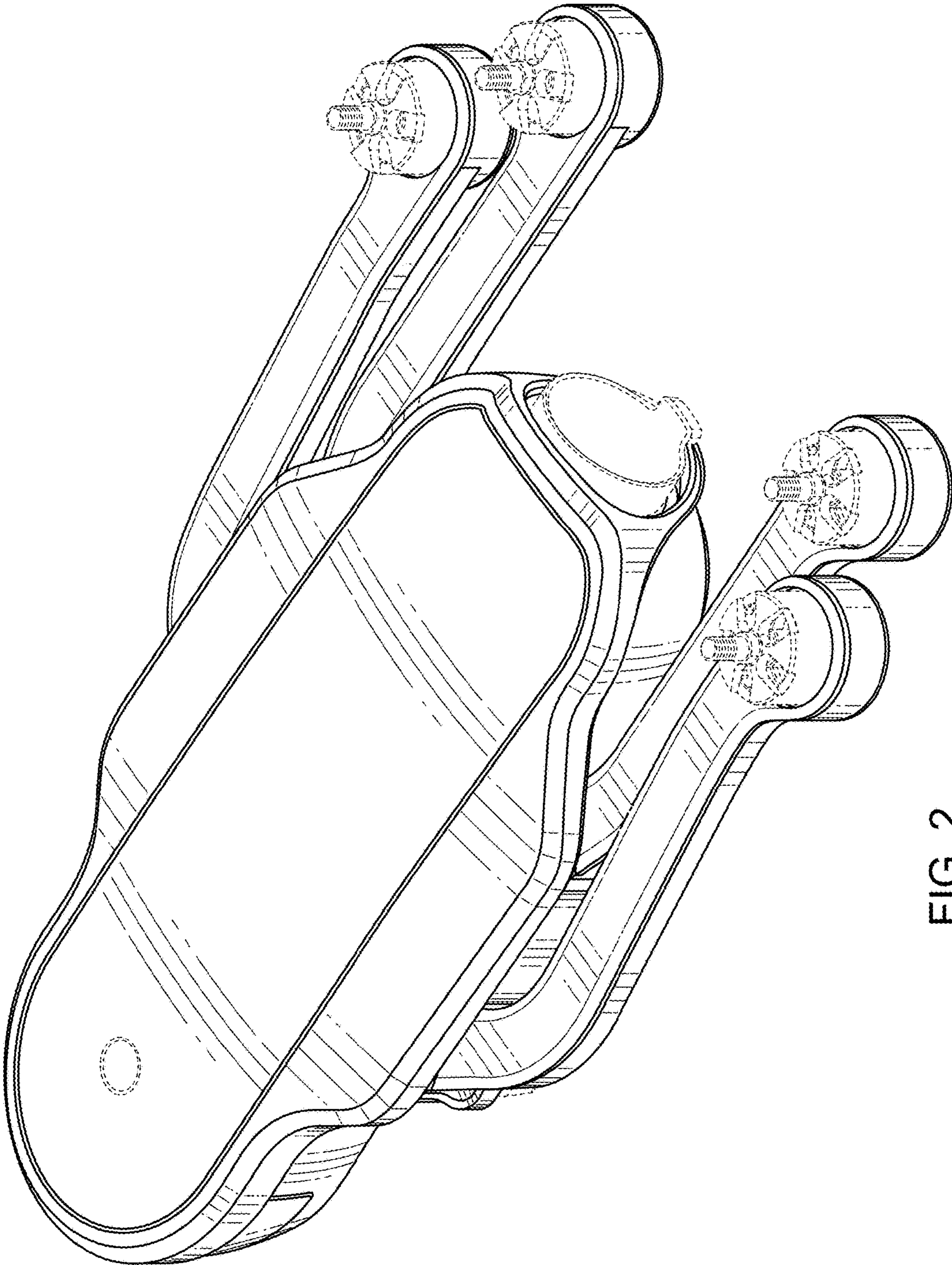

FIG. 2

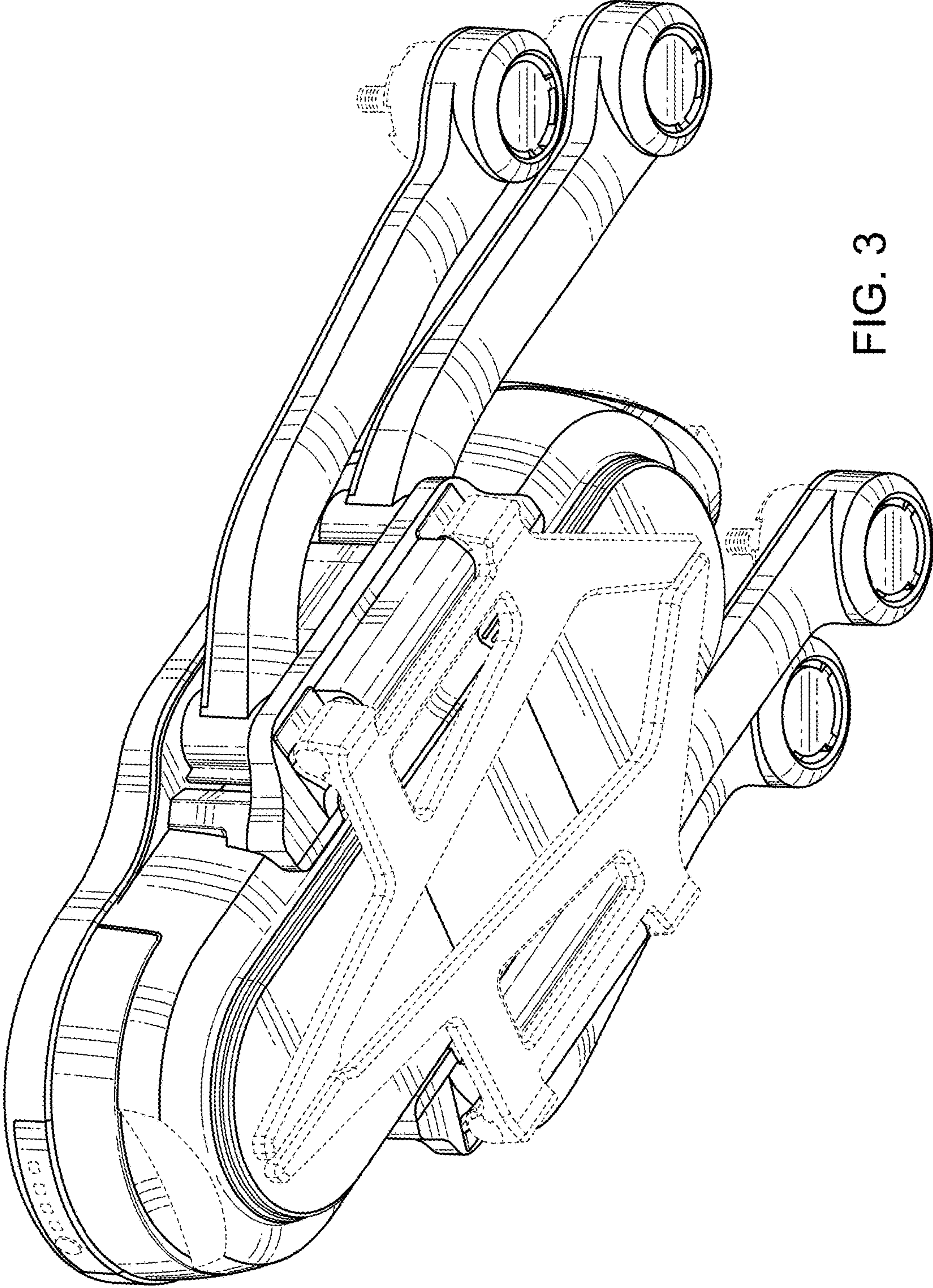

FIG. 3

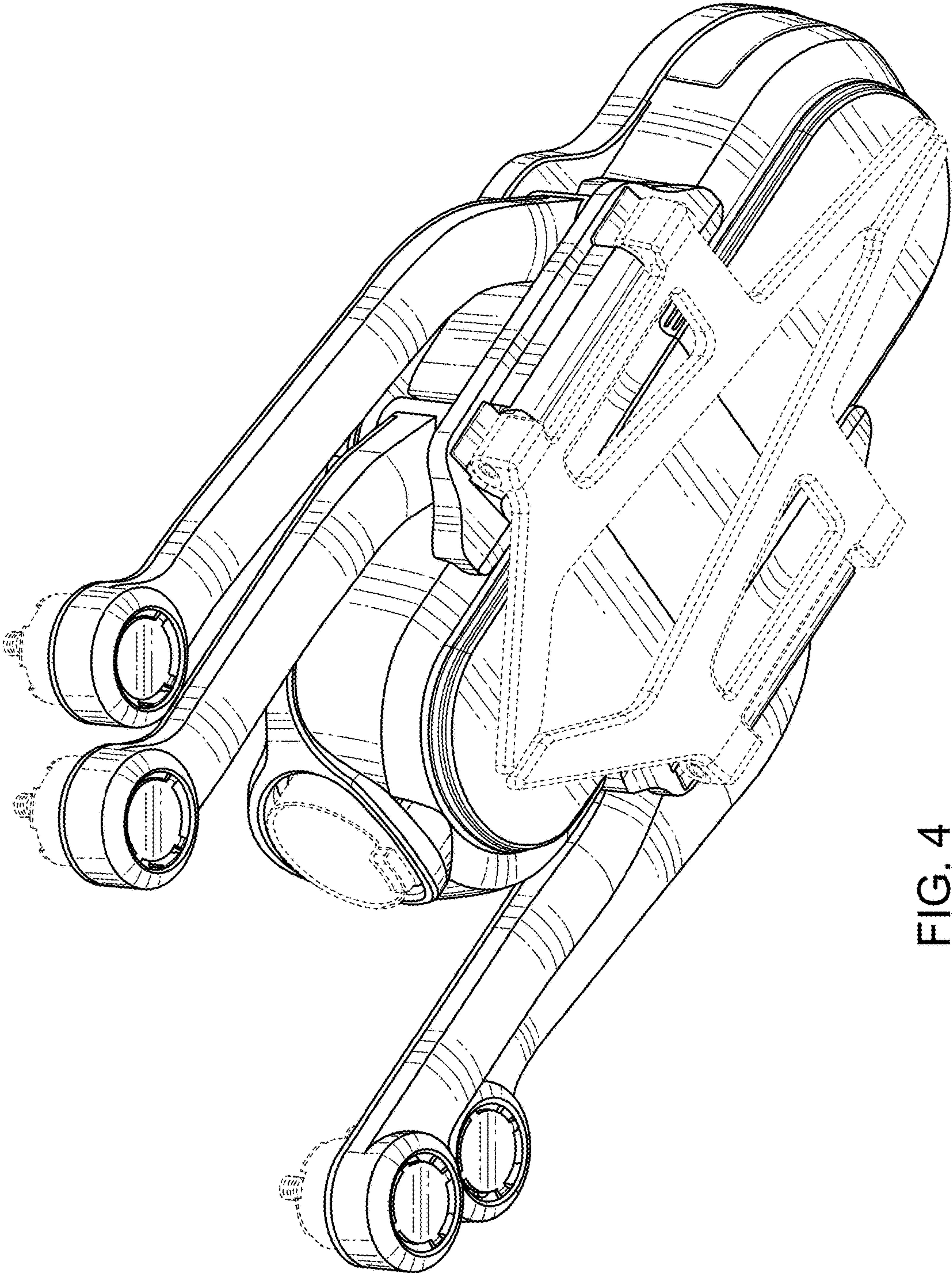

FIG. 4

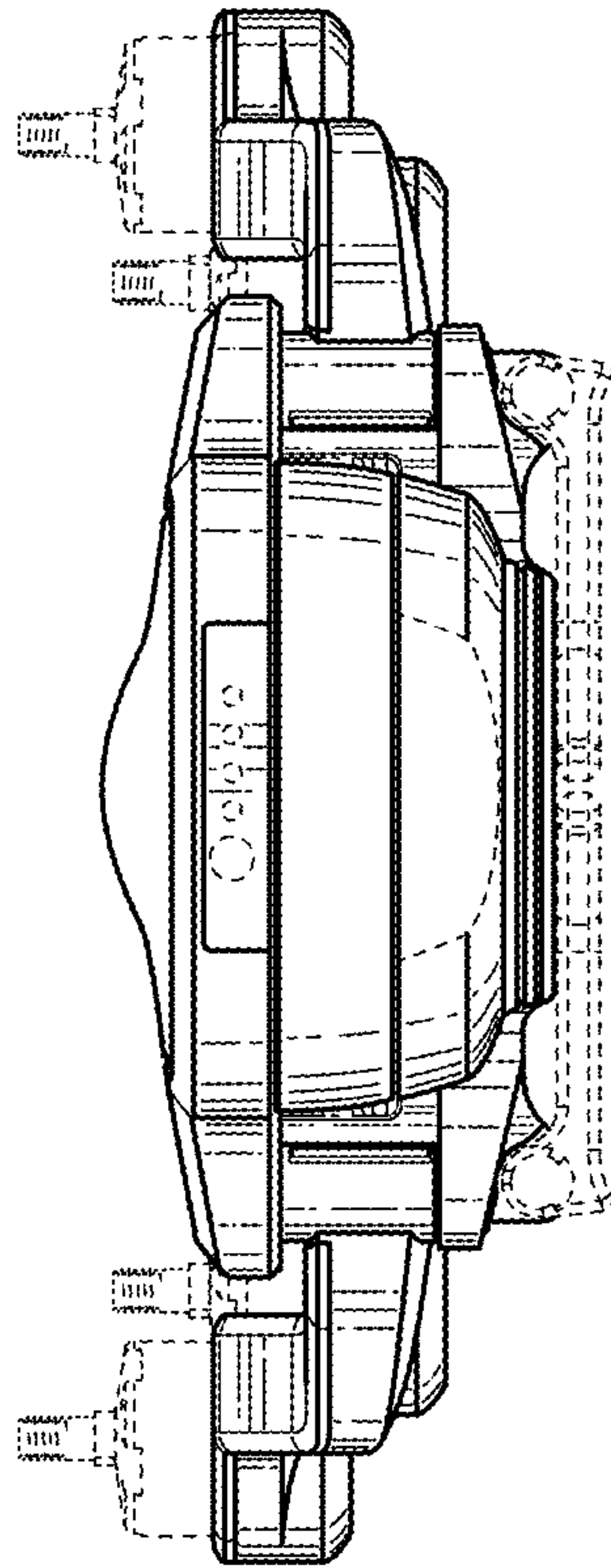

FIG. 5

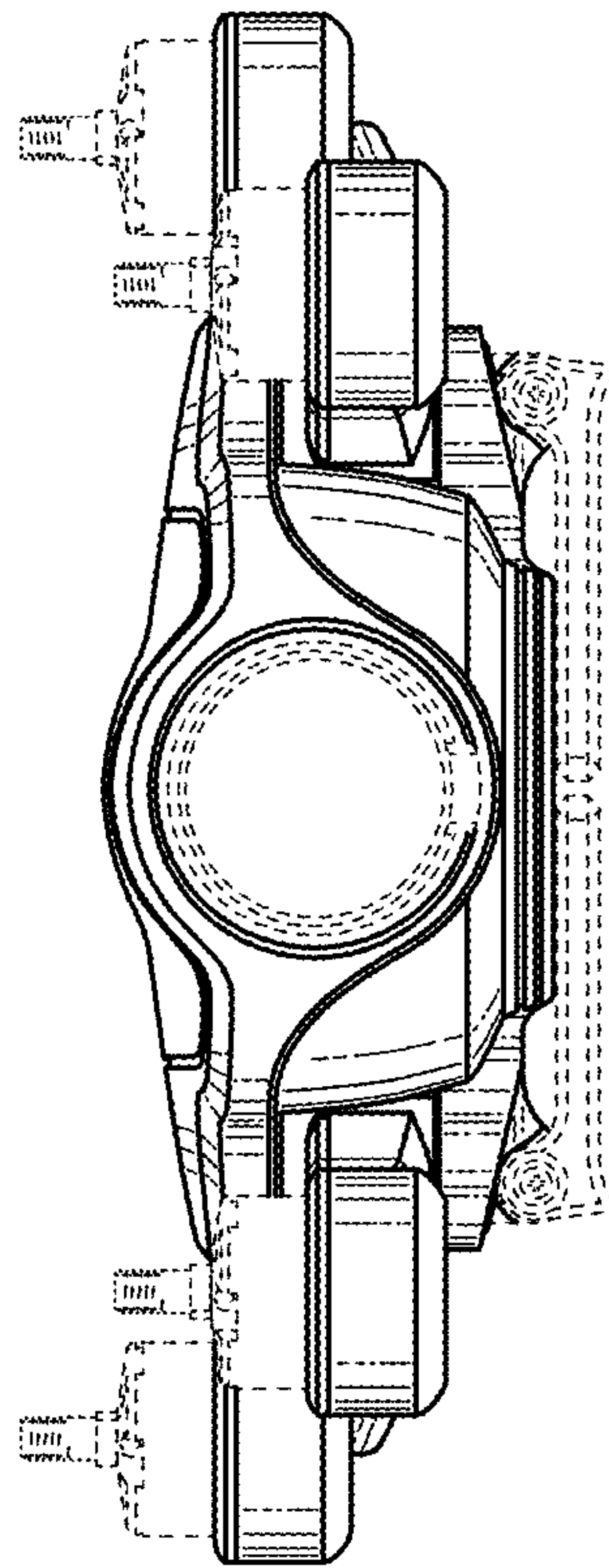

FIG. 6

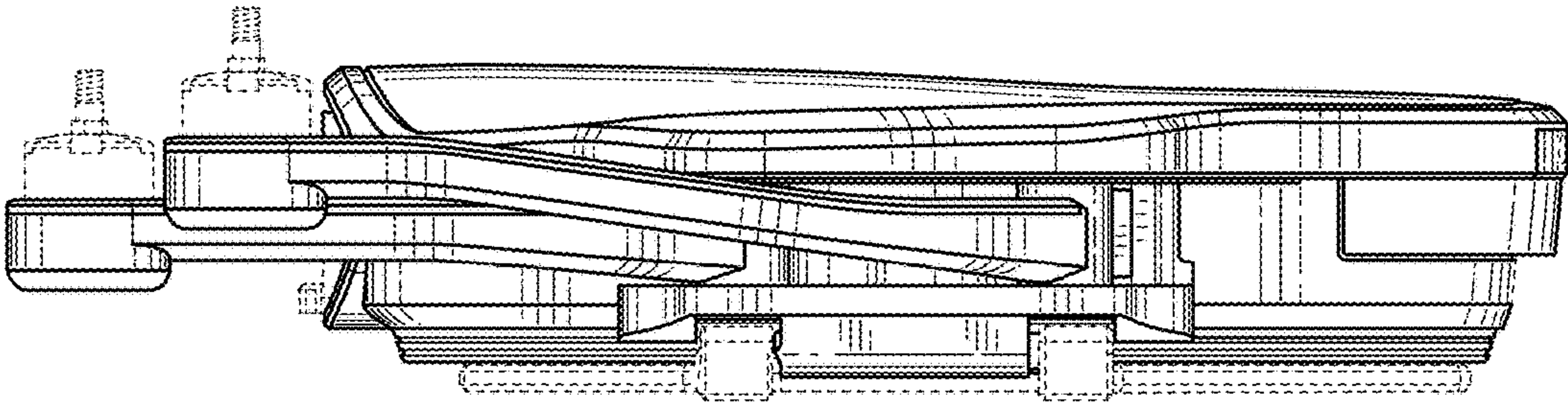

FIG. 7

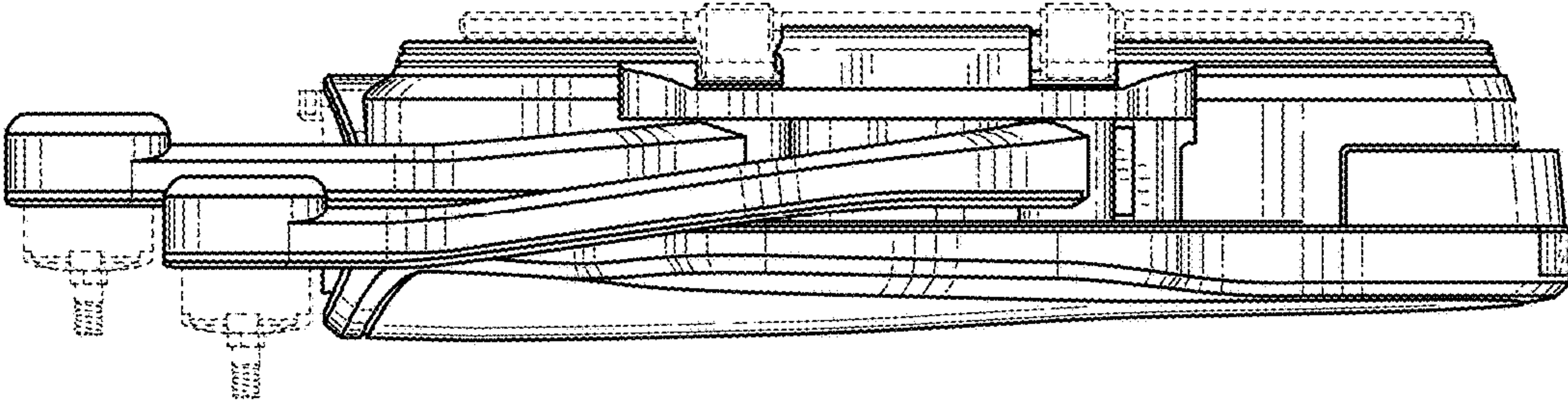

FIG. 8

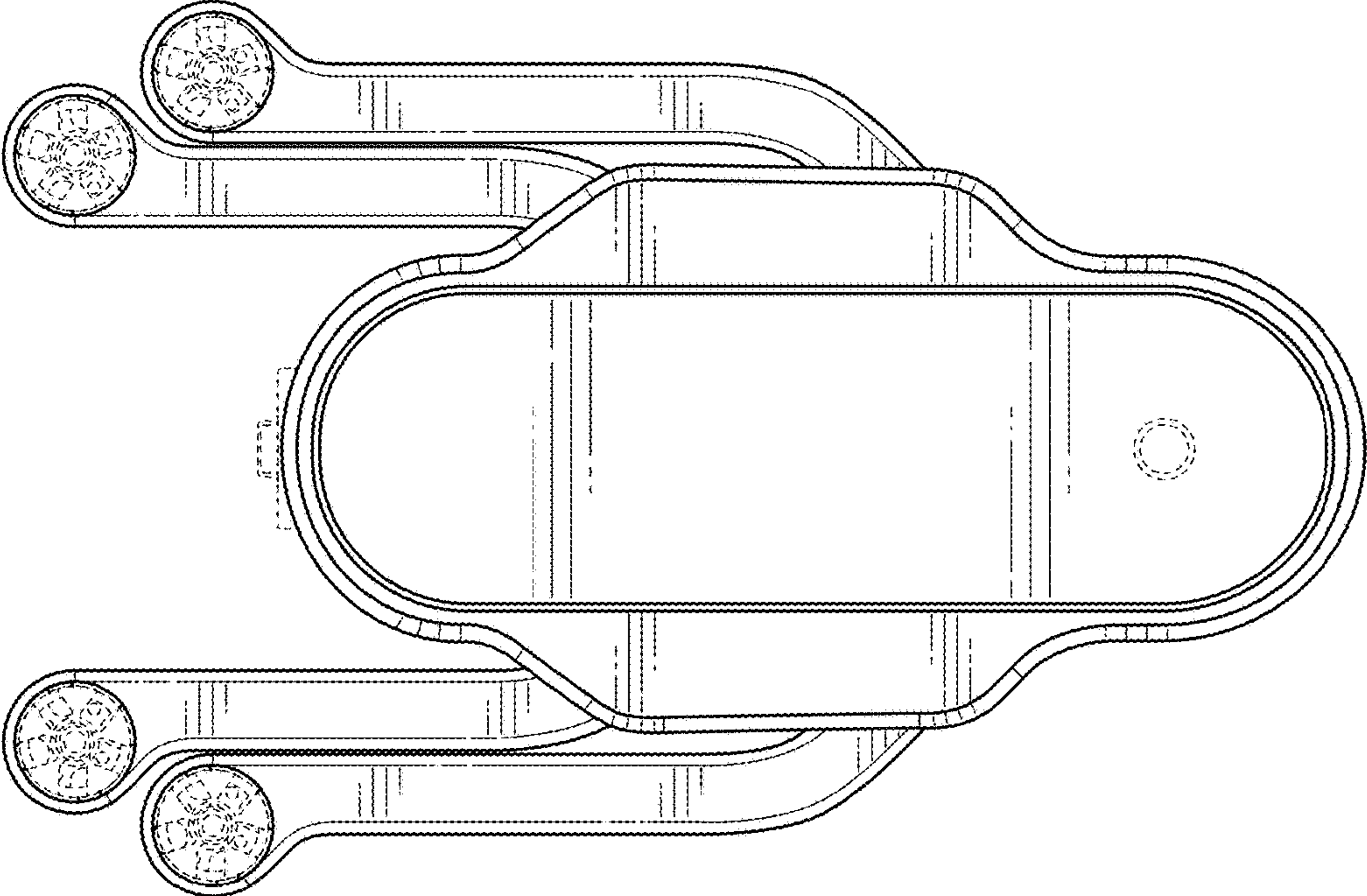

FIG. 9

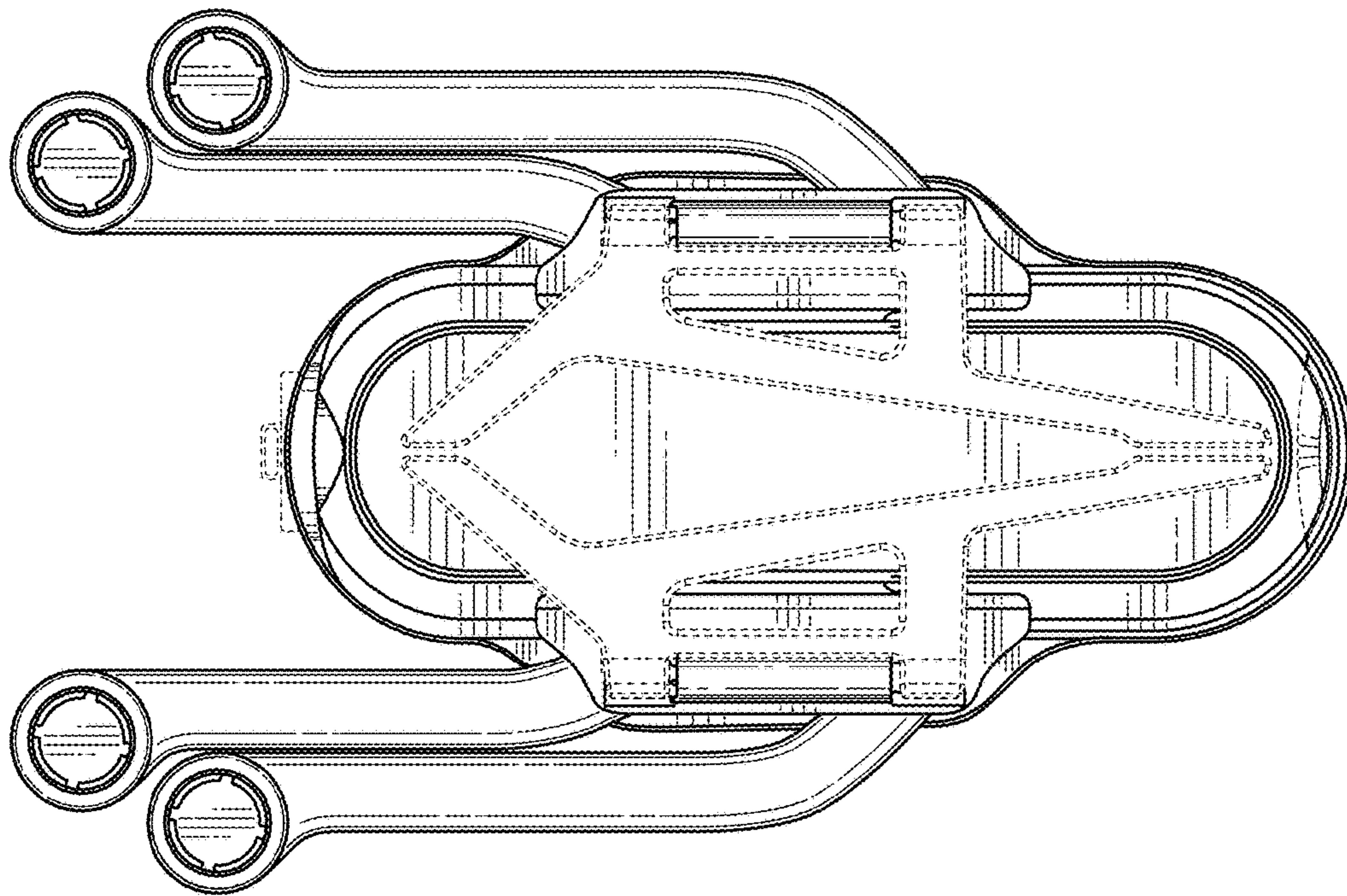

FIG. 10

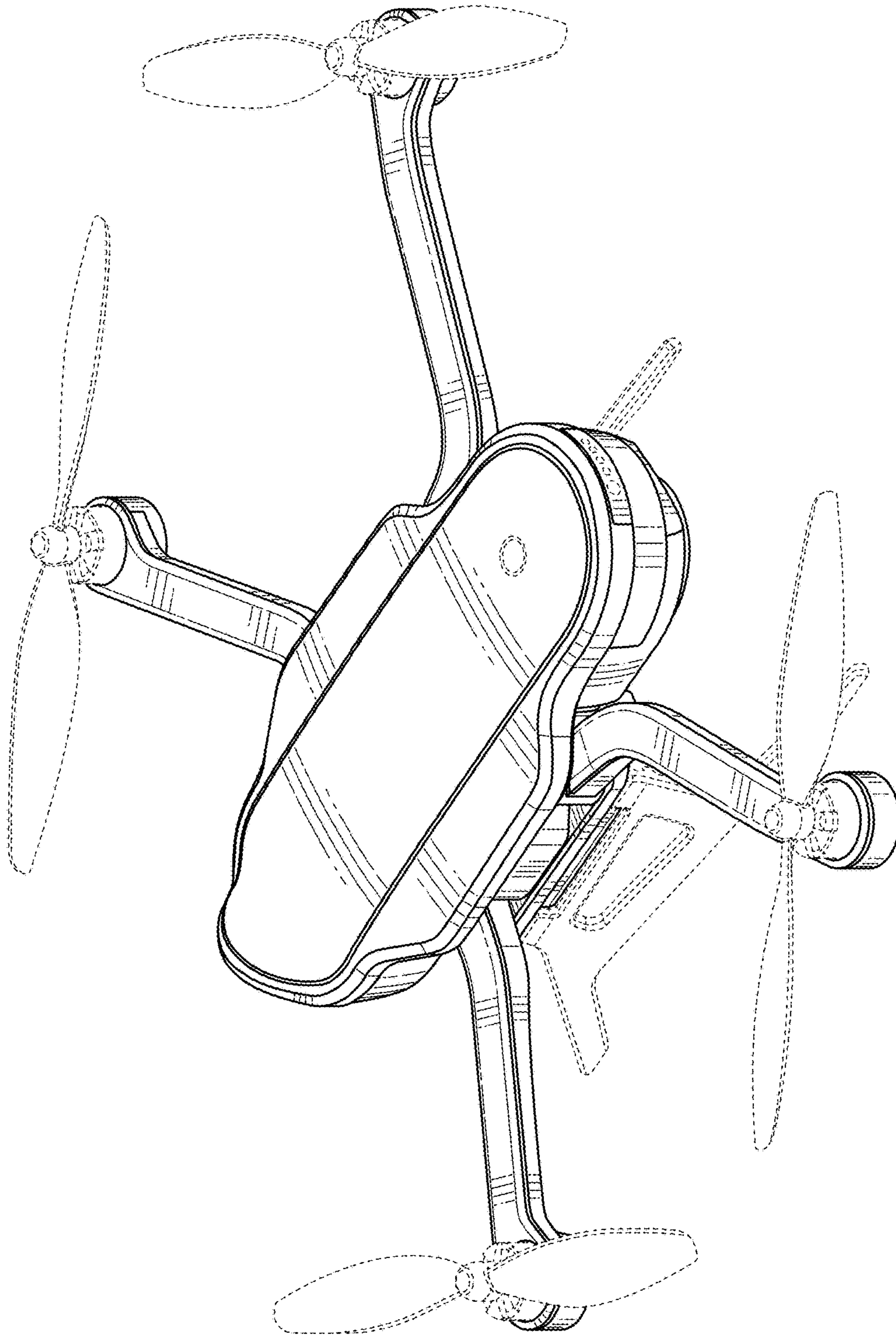

FIG. 11

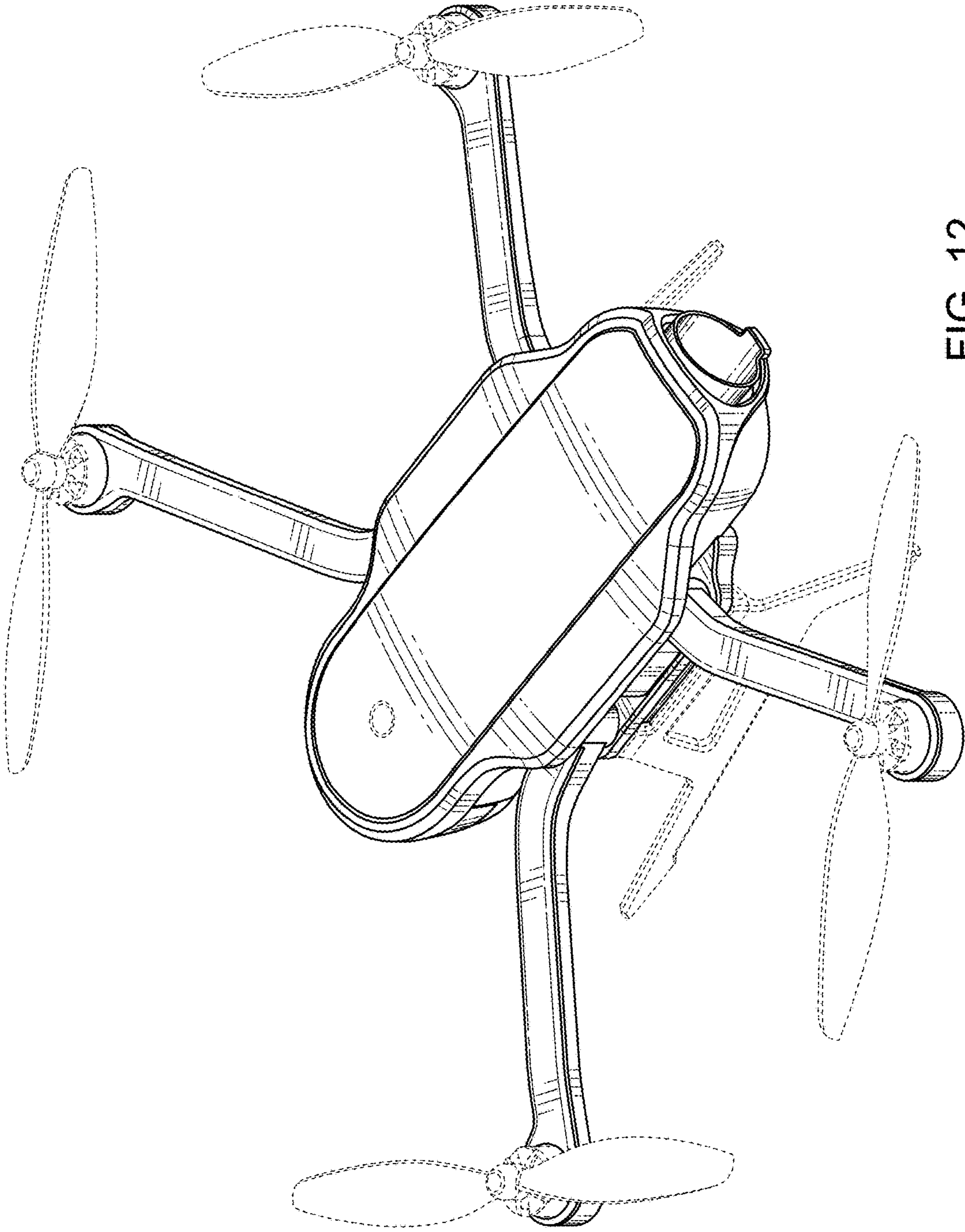

FIG. 12

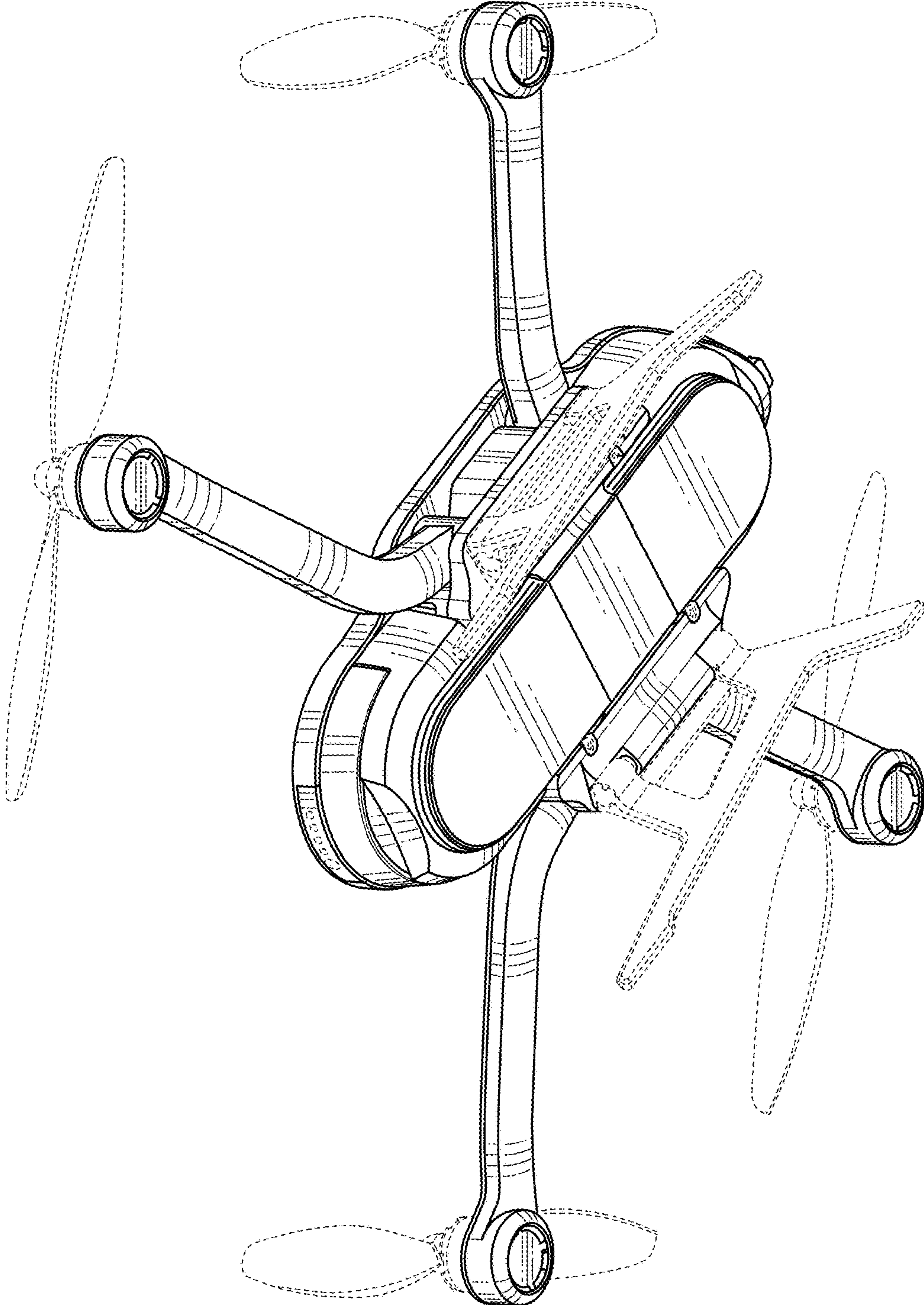

FIG. 13

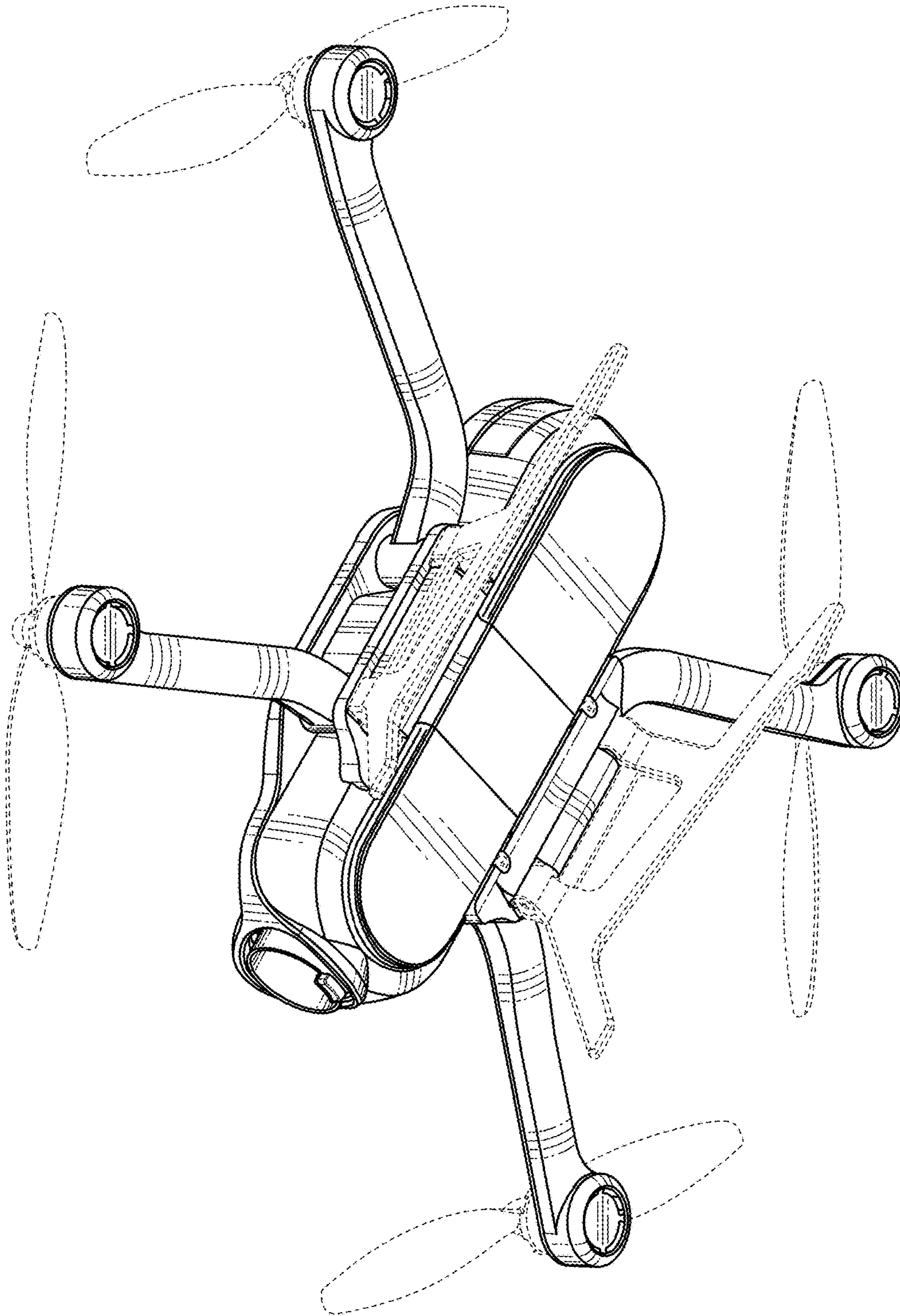

FIG. 14

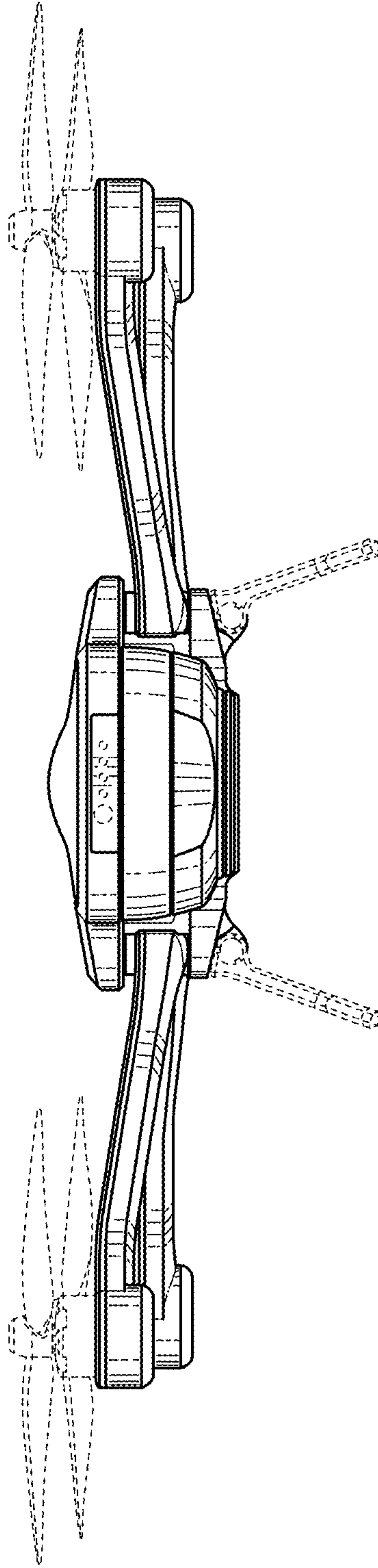

FIG. 15

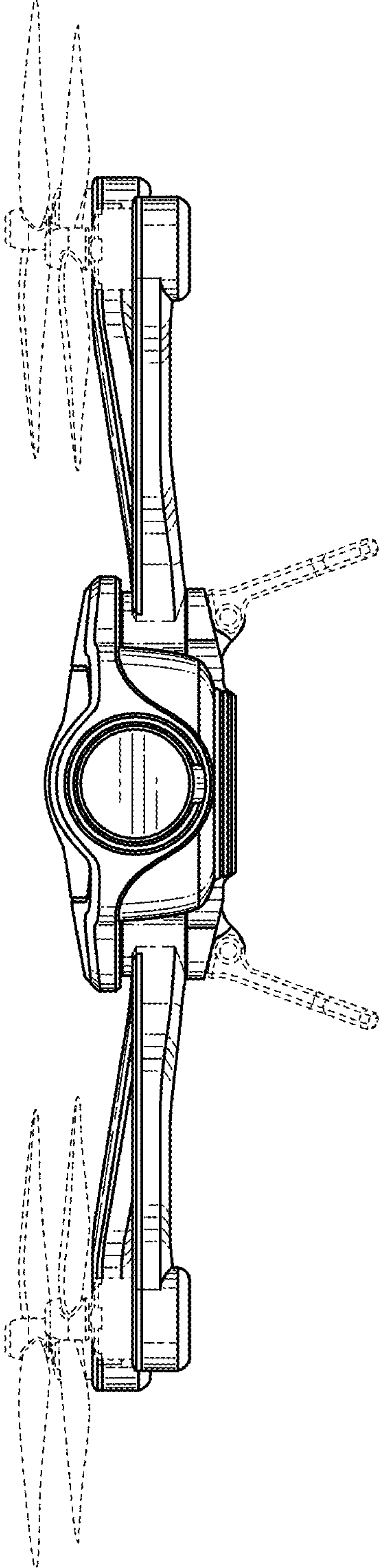

FIG. 16

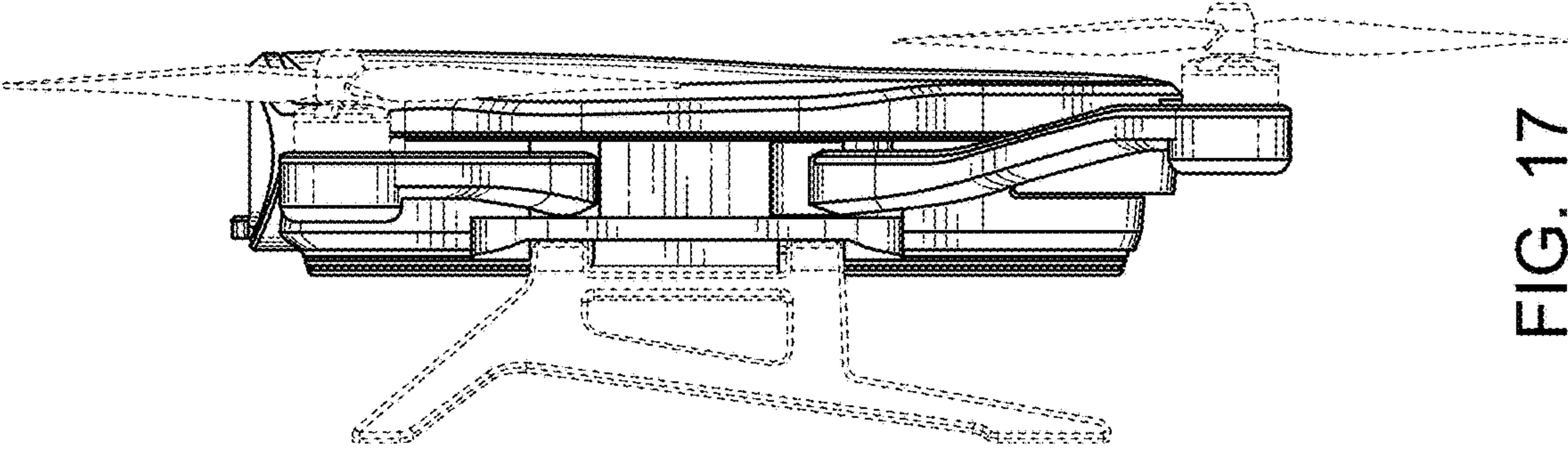

FIG. 17

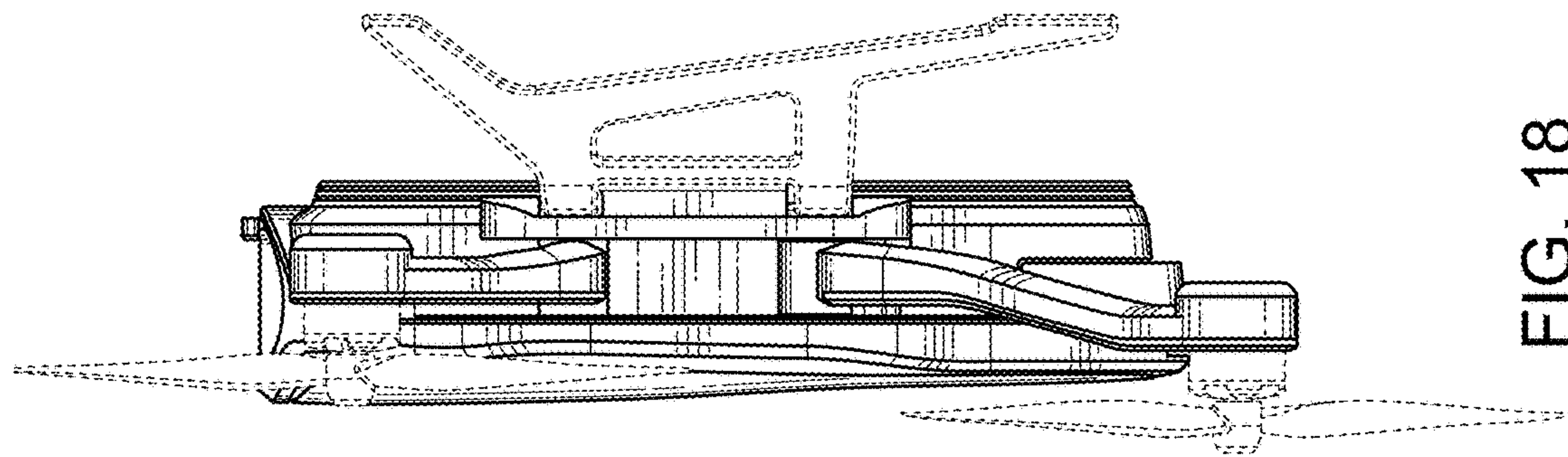

FIG. 18

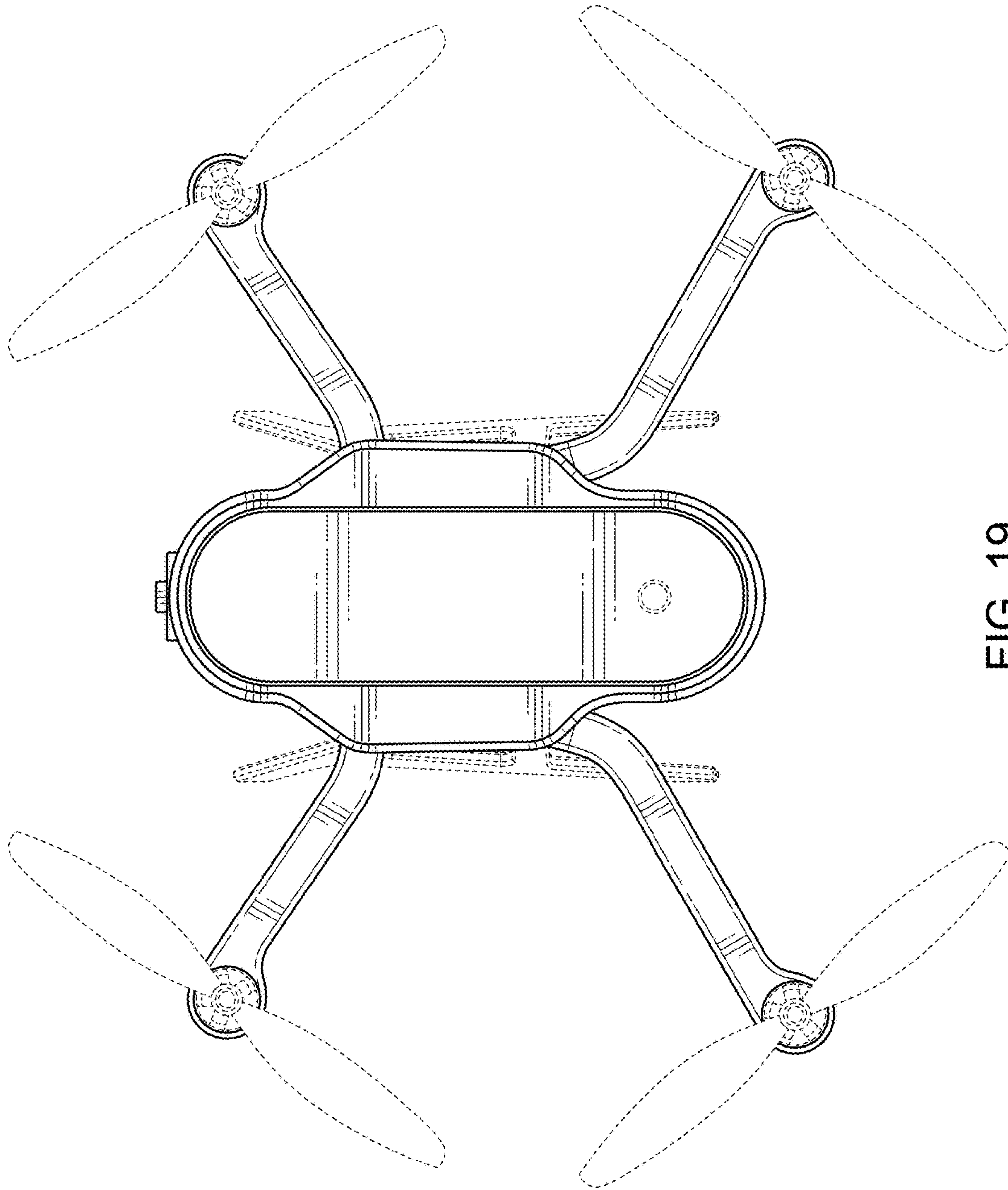

FIG. 19

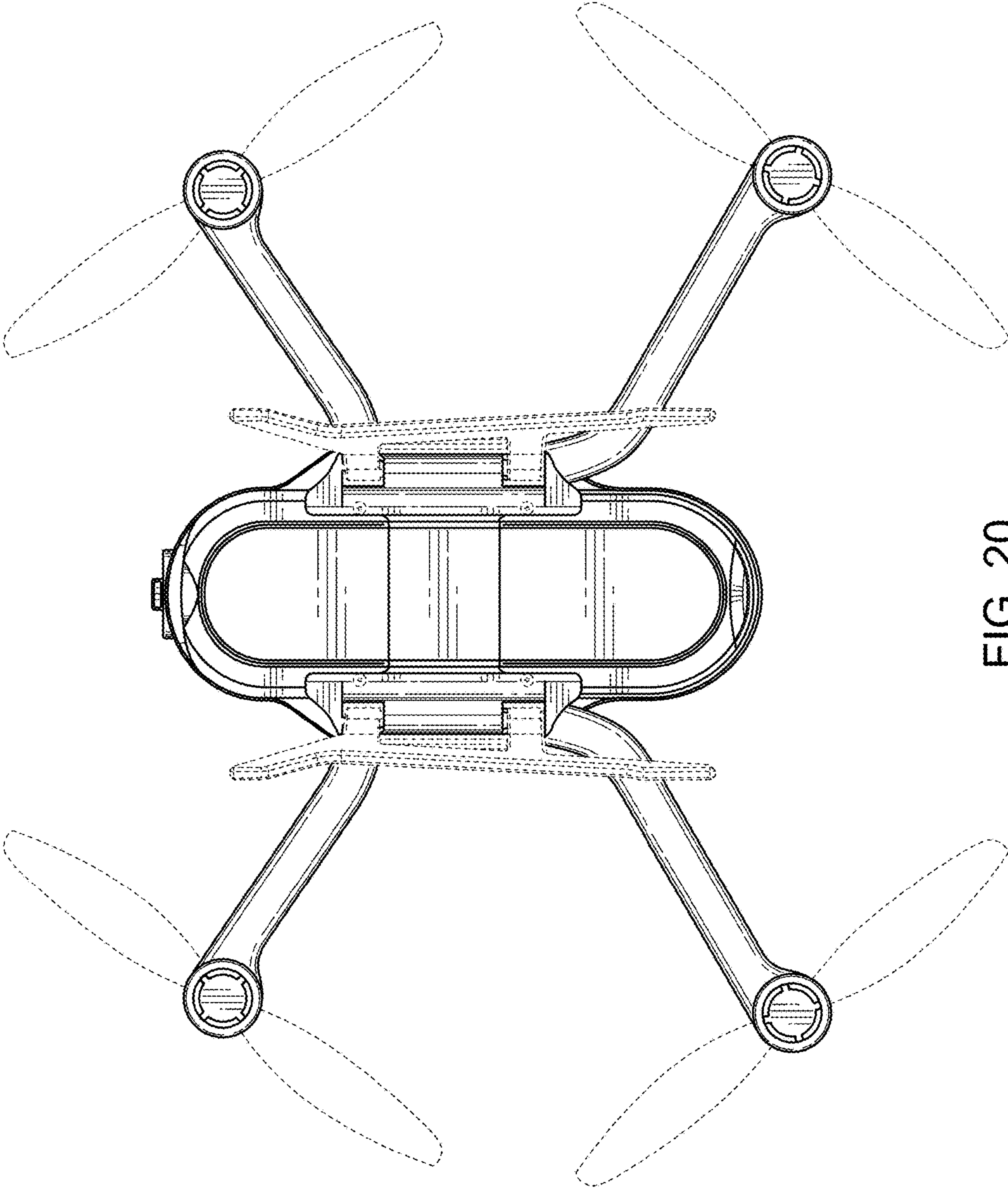

FIG. 20