



US00D802810S

(12) **United States Design Patent** (10) **Patent No.:** **US D802,810 S**
Johns et al. (45) **Date of Patent:** **** Nov. 14, 2017**

- (54) **VEHICLE LIGHT GUARD**
- (71) Applicant: **Omix-Ada, Inc.**, Suwanee, GA (US)
- (72) Inventors: **Taylor E. Johns**, Atlanta, GA (US);
Patrick W. Bennett, Gainesville, GA (US)
- (73) Assignee: **Omix-ADA, Inc.**, Suwanee, GA (US)
- (**) Term: **15 Years**
- (21) Appl. No.: **29/580,359**
- (22) Filed: **Oct. 7, 2016**
- (51) **LOC (10) Cl.** **26-06**
- (52) **U.S. Cl.**
USPC **D26/28**
- (58) **Field of Classification Search**
USPC D26/28-36; 362/80-83, 267-269,
362/459-468, 475-478, 485-487
CPC F21S 48/00; F21S 48/10; F21S 48/115;
F21S 48/1233; F21S 48/1266; F21S
48/1388; F21S 48/2268; F21V 21/04
See application file for complete search history.

- D390,821 S 2/1998 Thorne et al.
- D425,240 S * 5/2000 Goeckeritz D26/139
- D432,064 S 10/2000 Hartog
- 7,314,245 B1 1/2008 Shymkiw
- D676,599 S * 2/2013 Davidson D26/139
- D721,454 S 1/2015 King et al.

* cited by examiner

Primary Examiner — Marcus Jackson
 (74) *Attorney, Agent, or Firm* — Womble Carlyle
 Sandridge & Rice LLP

(57) **CLAIM**

The ornamental design for a vehicle light guard, as shown and described.

DESCRIPTION

FIG. 1 is a perspective view of a vehicle light guard that embodies our ornamental design;
 FIG. 2 is a front view thereof.
 FIG. 3 is a back view thereof.
 FIG. 4 is a left side view thereof.
 FIG. 5 is a right side view thereof.
 FIG. 6 is a top view thereof.
 FIG. 7 is a bottom view thereof; and,
 FIG. 8 is a perspective view of the vehicle light guard shown covering a vehicle light.
 The broken lines in the drawings illustrate elements that form no part of the claimed design.

(56) **References Cited**

U.S. PATENT DOCUMENTS

- D316,460 S * 4/1991 Neece D26/120
- D364,704 S 11/1995 Alger

1 Claim, 6 Drawing Sheets

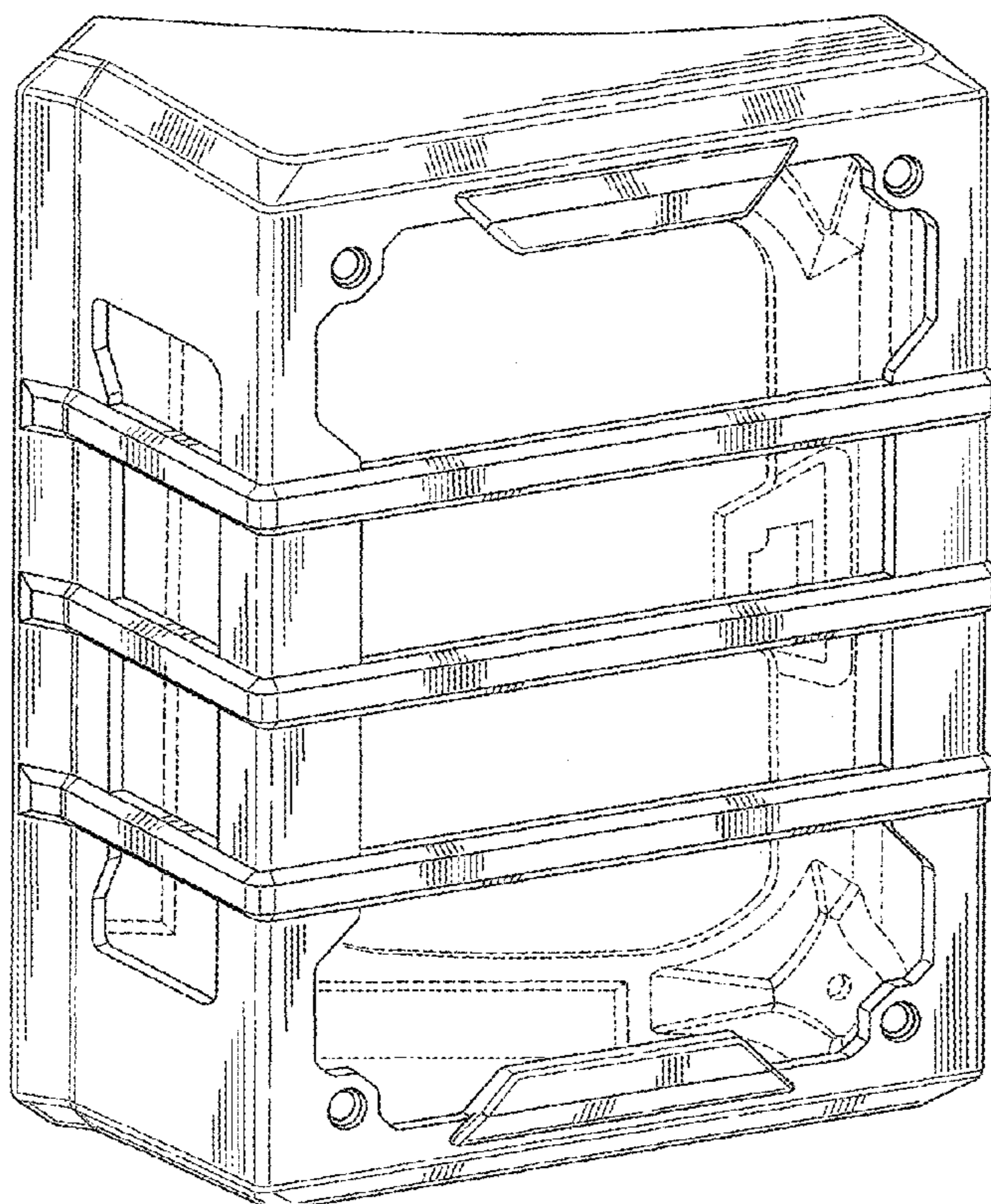

FIG. 1

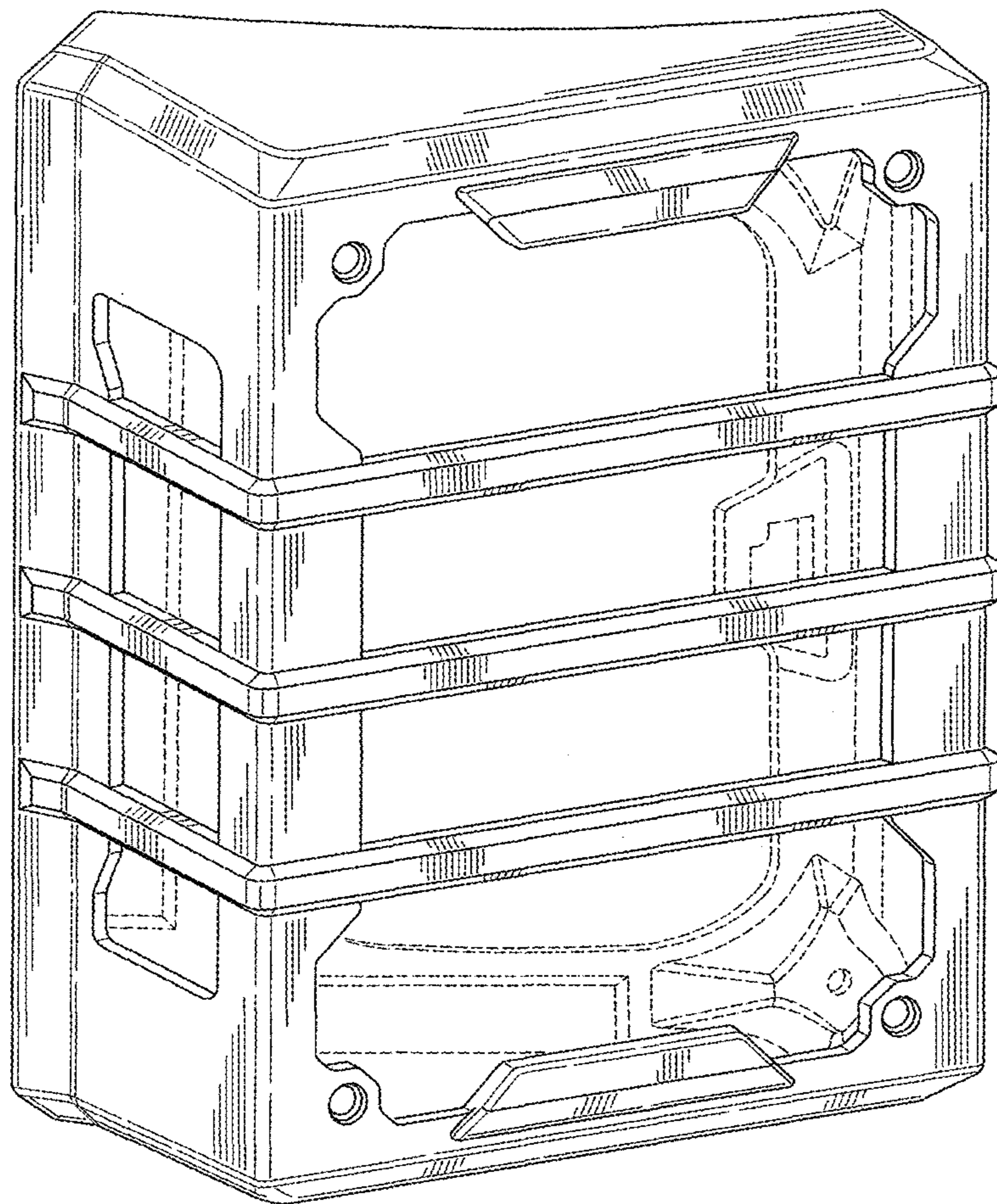

FIG. 2

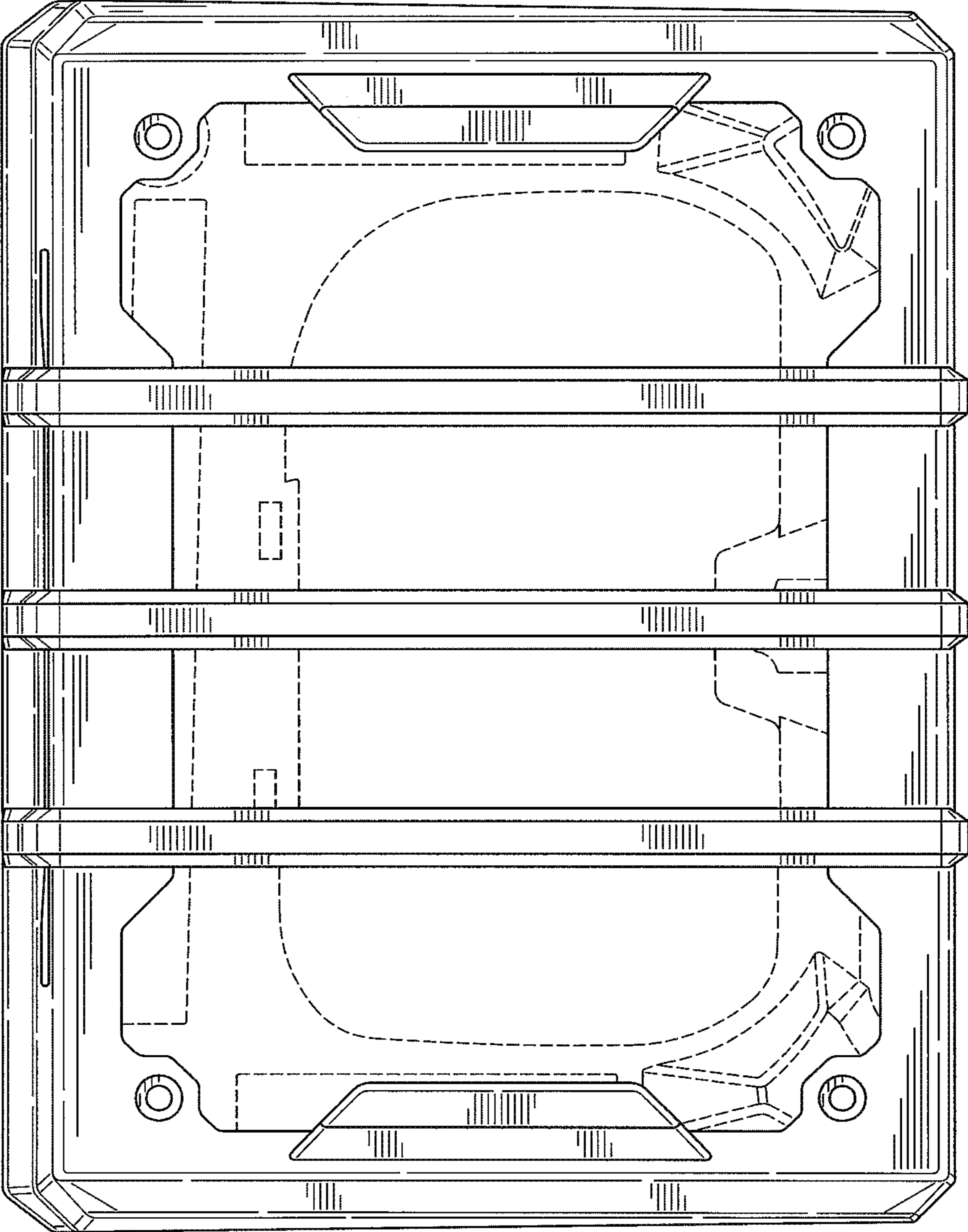

FIG. 3

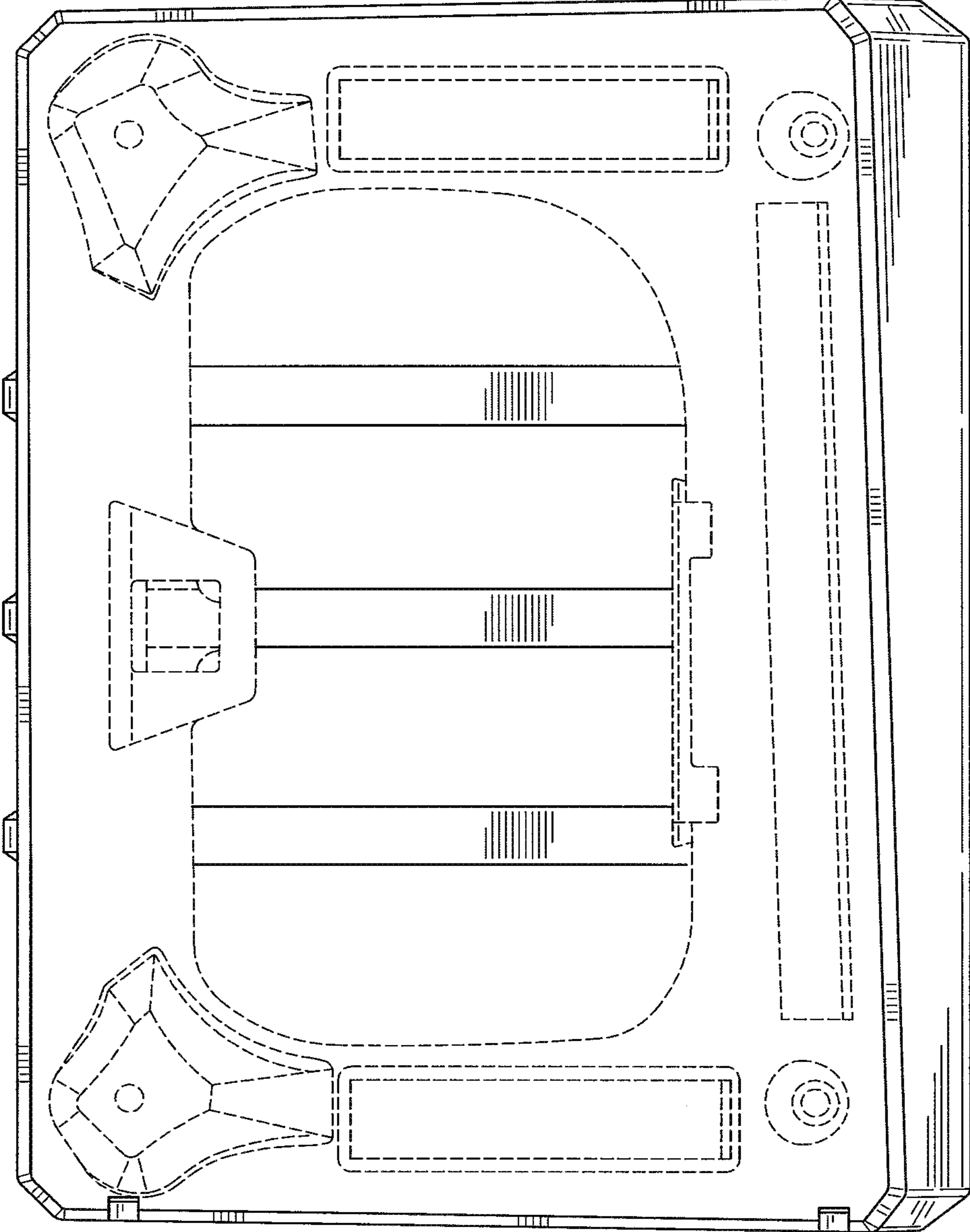

FIG. 4

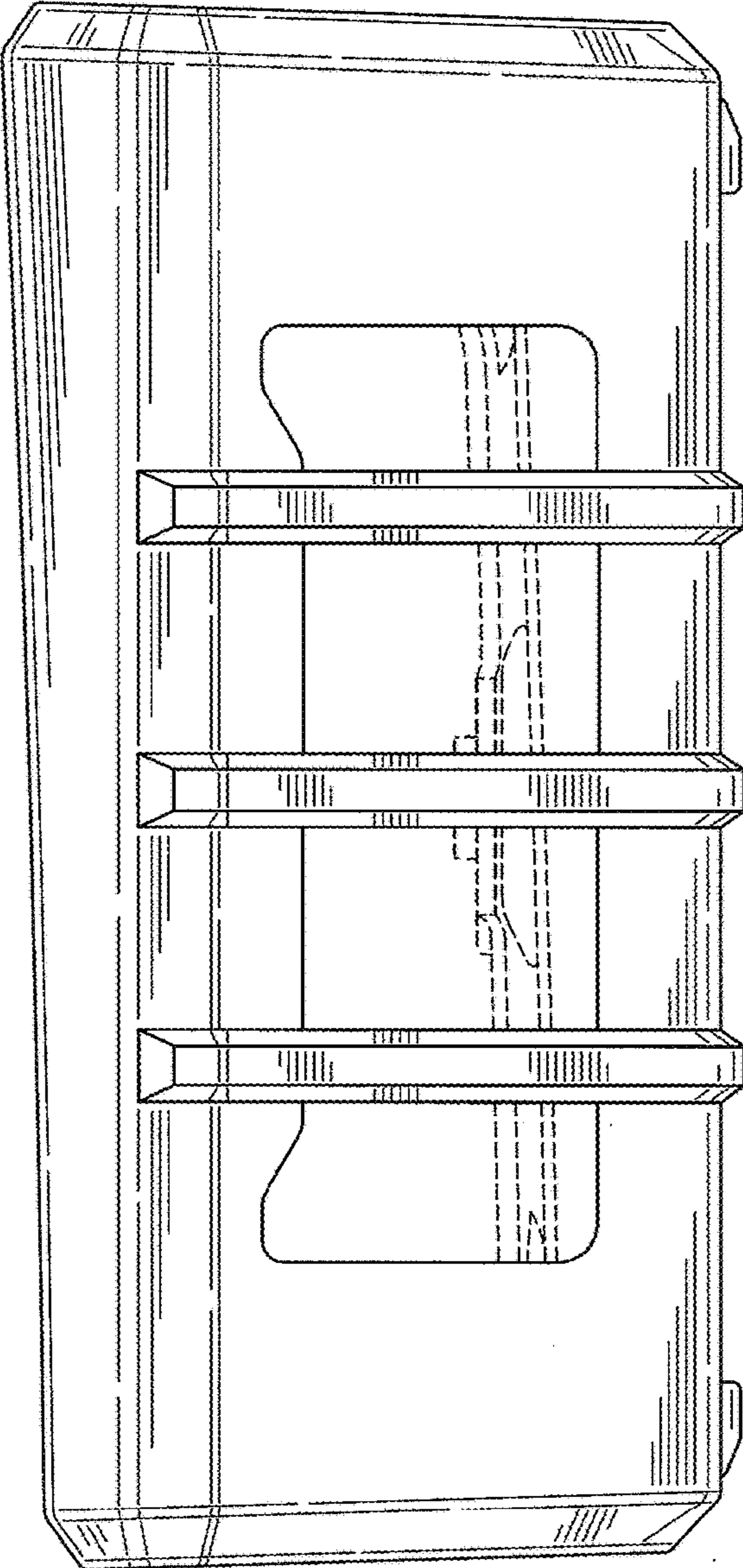
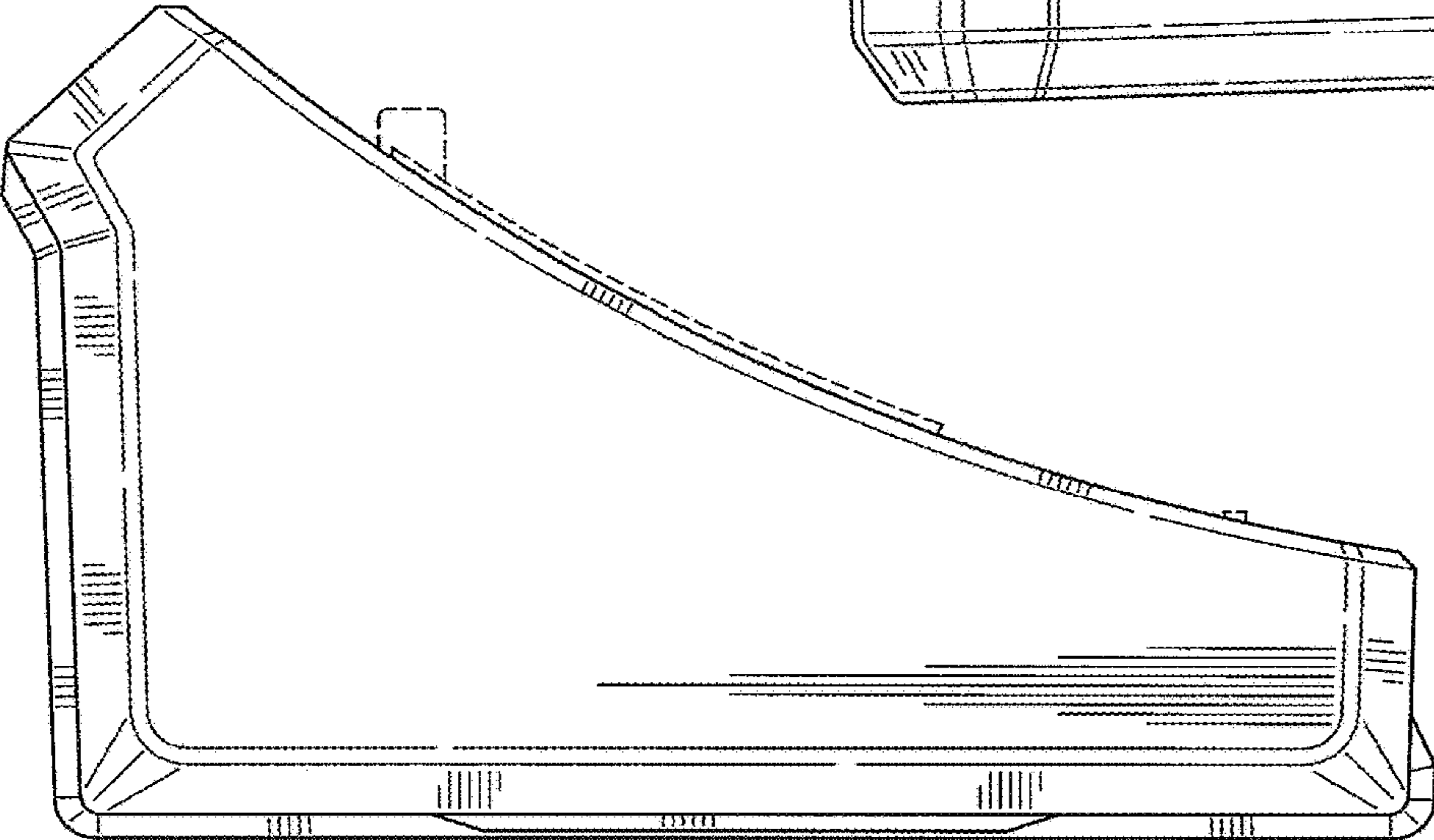

FIG. 6



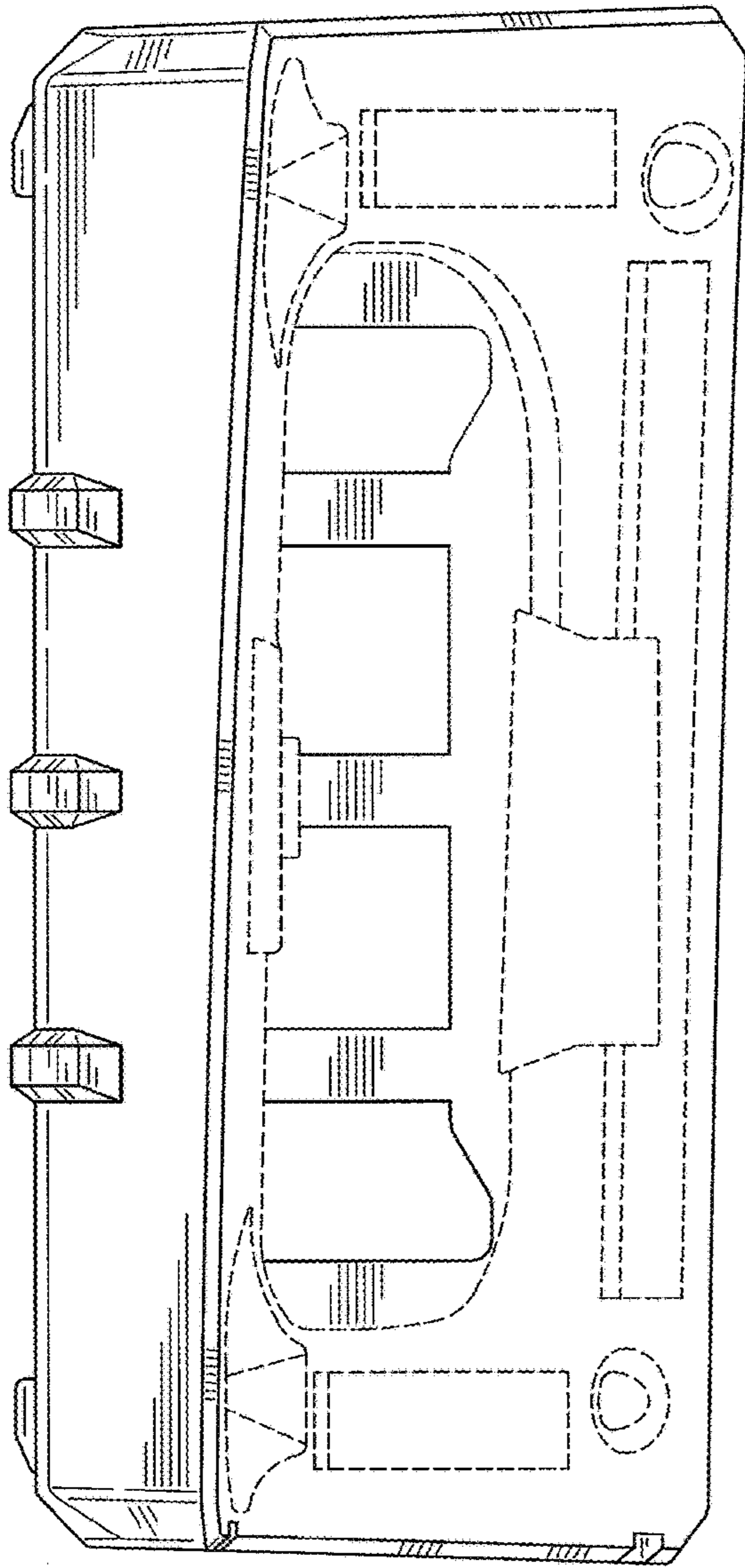
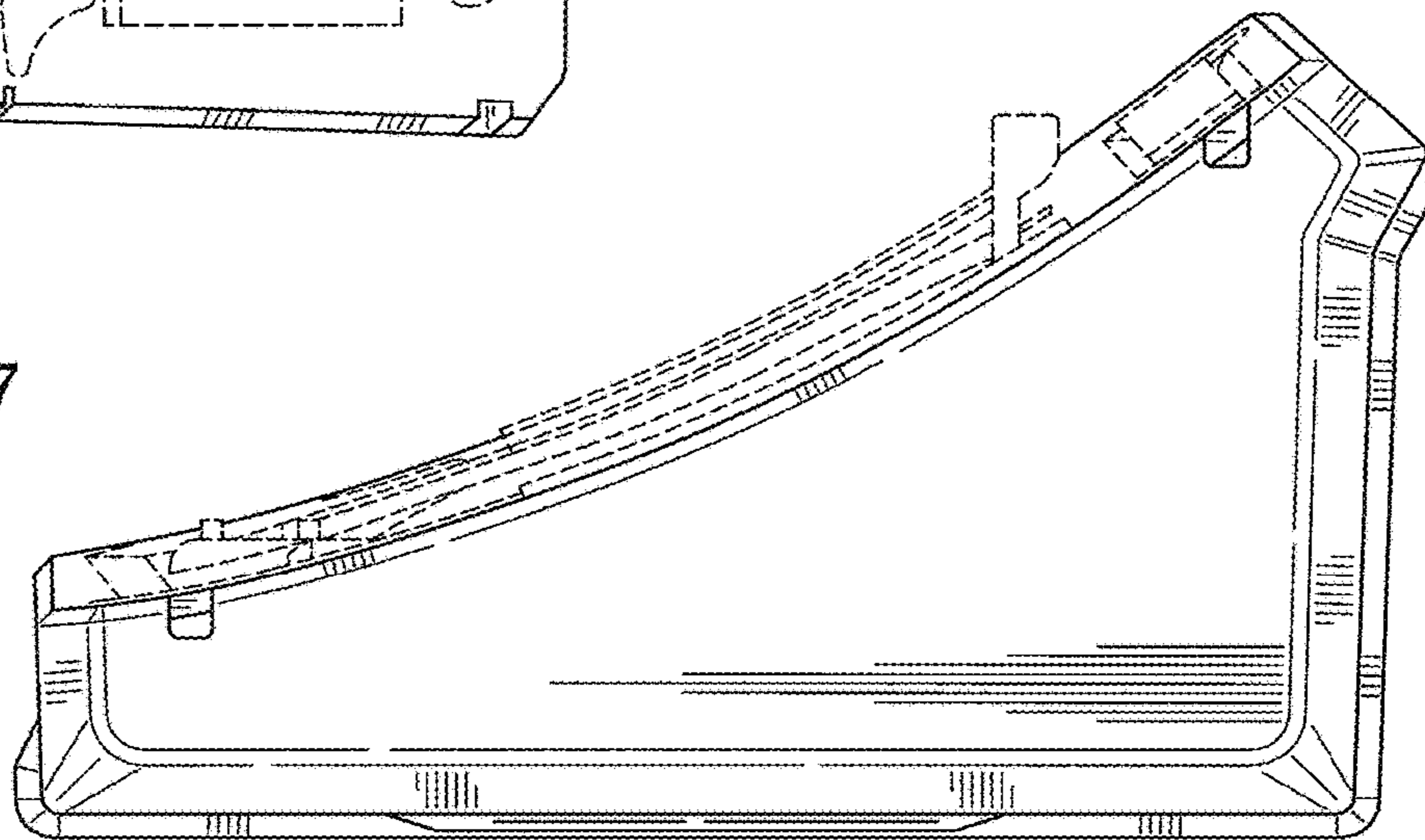

FIG. 5

FIG. 7



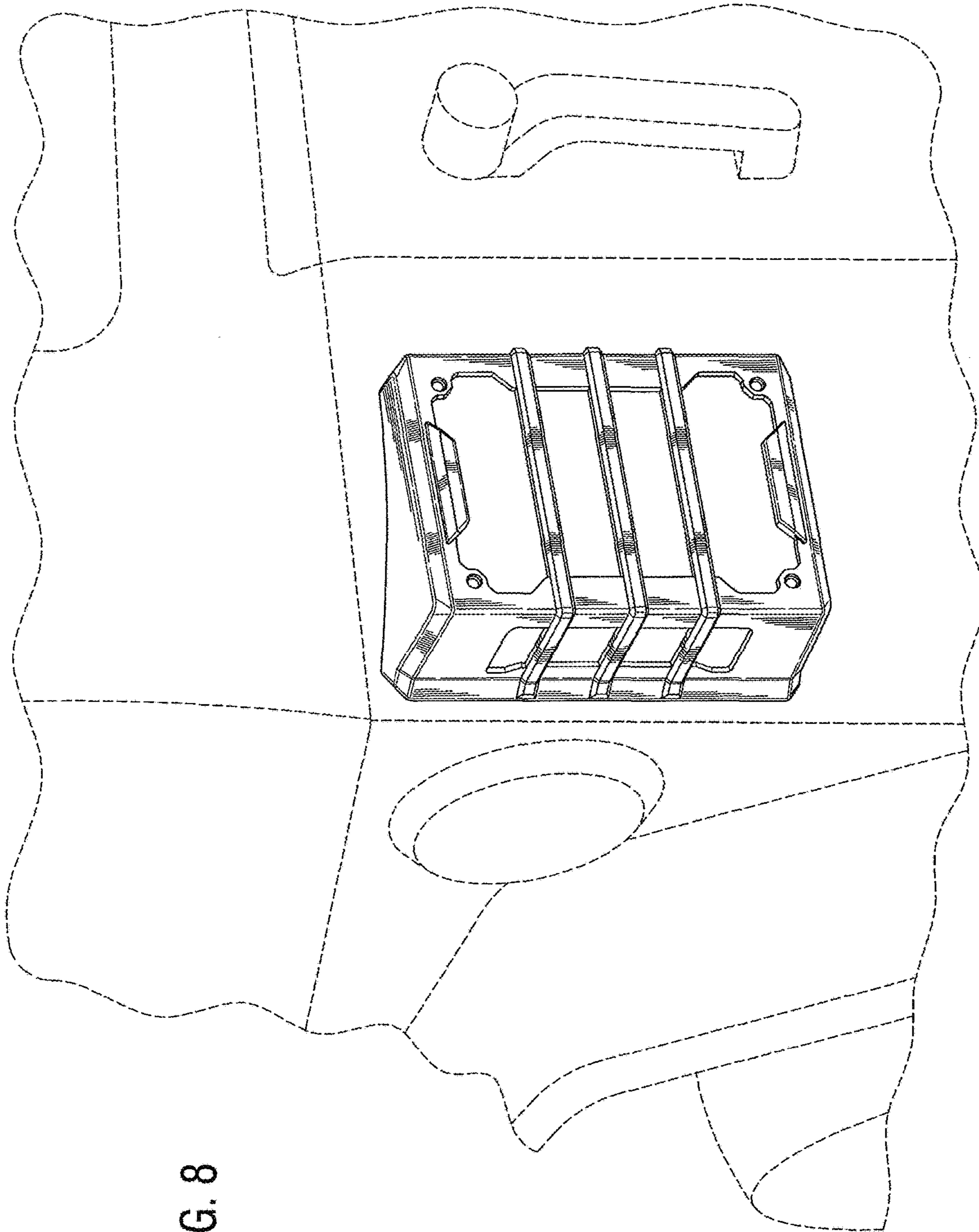

FIG. 8