



US00D802531S

(12) **United States Design Patent**  
**Liao et al.**

(10) **Patent No.:** **US D802,531 S**

(45) **Date of Patent:** **\*\* Nov. 14, 2017**

(54) **TURBOCHARGER ADAPTER**

7,984,934 B1 \* 7/2011 Blaton ..... F16L 13/08  
285/13

(71) Applicants: **Ying-Chieh Liao**, Taichung (TW);  
**Yu-Kuo Liao**, Taichung (TW)

D681,159 S \* 4/2013 Ben-Horin ..... D23/209  
D690,336 S \* 9/2013 Gjertsen ..... D15/144  
2010/0180592 A1 \* 7/2010 Williams ..... F01D 17/165  
60/602

(72) Inventors: **Ying-Chieh Liao**, Taichung (TW);  
**Yu-Kuo Liao**, Taichung (TW)

(\*\*) Term: **14 Years**

**OTHER PUBLICATIONS**

Amazon.com: Gates Turbocharger Intercooler Hose Kit, Jul. 2017.\*

(21) Appl. No.: **29/521,482**

\* cited by examiner

(22) Filed: **Mar. 24, 2015**

*Primary Examiner* — Derrick Holland

(51) **LOC (10) Cl.** ..... **13-01**

(74) *Attorney, Agent, or Firm* — Muncy, Geissler, Olds & Lowe, P.C.

(52) **U.S. Cl.**

USPC ..... **D13/122; D15/5**

(58) **Field of Classification Search**

(57) **CLAIM**

USPC ..... D13/118, 122, 133, 149, 150, 151, 155,  
D13/199; D15/5, 9, 144, 148, 199;  
D23/259, 262; D12/194, 400

We claim the ornamental design for a turbocharger adapter,  
as shown and described.

CPC ..... F01D 25/00; F01D 25/24; F01D 25/26;  
F01D 25/30; F01D 25/243; F01D 25/246;  
F01D 25/265; F01D 21/045; F02B  
37/004; F02B 37/013; F02B 37/10; F02B  
37/14; F02B 37/16; F02B 37/18; F02B  
37/22; F02B 37/24; F02B 37/183; F02C  
6/12; Y02T 10/144; Y02T 10/163

**DESCRIPTION**

See application file for complete search history.

FIG. 1 is a right, front, top perspective view of a turbo-  
charger adapter showing our new design;  
FIG. 2 is a front elevational view thereof;  
FIG. 3 is a rear elevational view thereof;  
FIG. 4 is a left side view thereof; the right side being a mirror  
image;  
FIG. 5 is a top plan view thereof;  
FIG. 6 is a bottom plan view thereof; and,  
FIG. 7 is a perspective view thereof, shown in an alternative  
environmental use.

(56) **References Cited**

**U.S. PATENT DOCUMENTS**

4,893,474 A \* 1/1990 Miller ..... F02B 37/18  
60/602  
D374,647 S \* 10/1996 Capra ..... D12/194

The broken lines in the drawings illustrate portions of the  
turbocharger adapter which form no part of the claimed  
design.

**1 Claim, 5 Drawing Sheets**

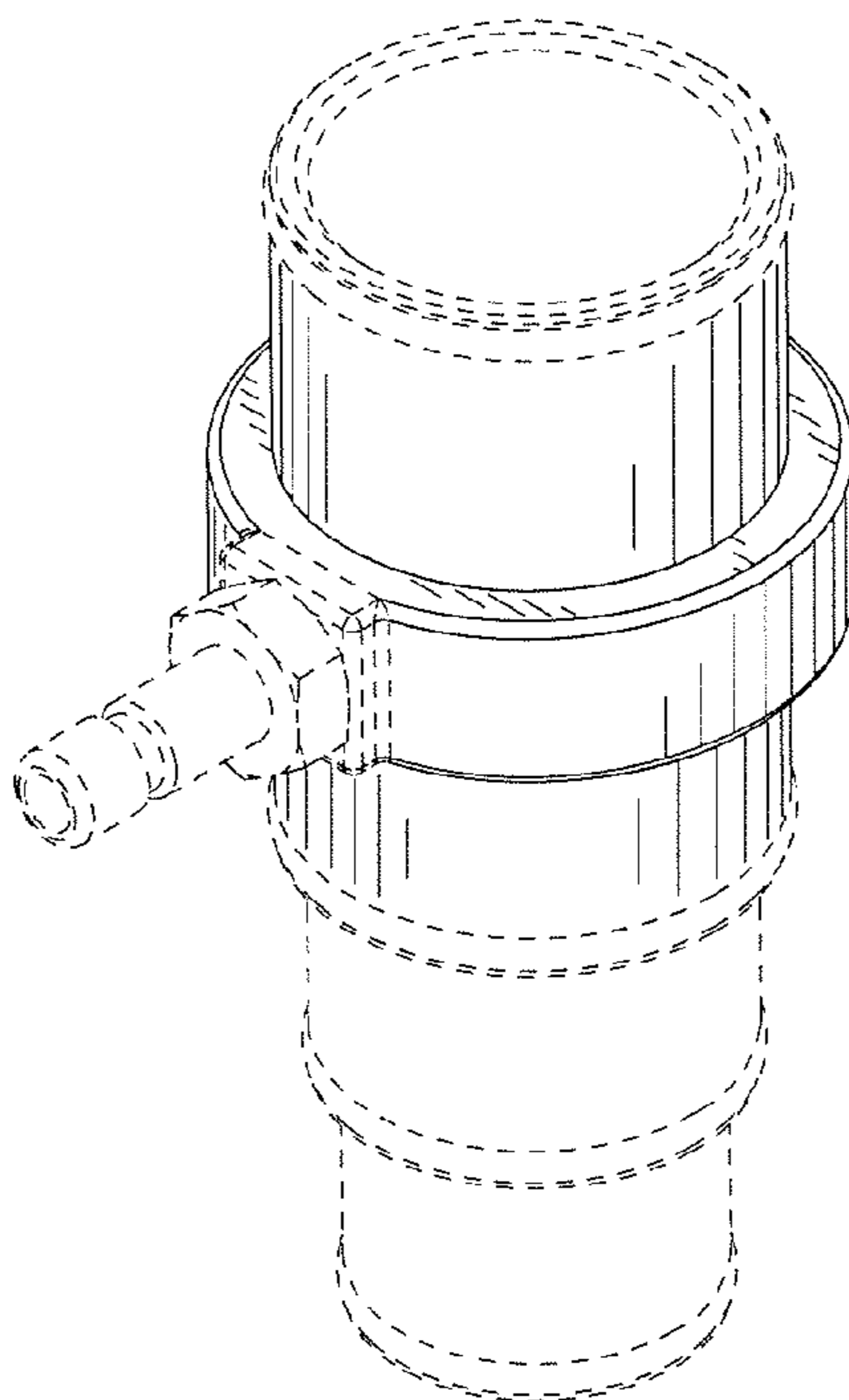

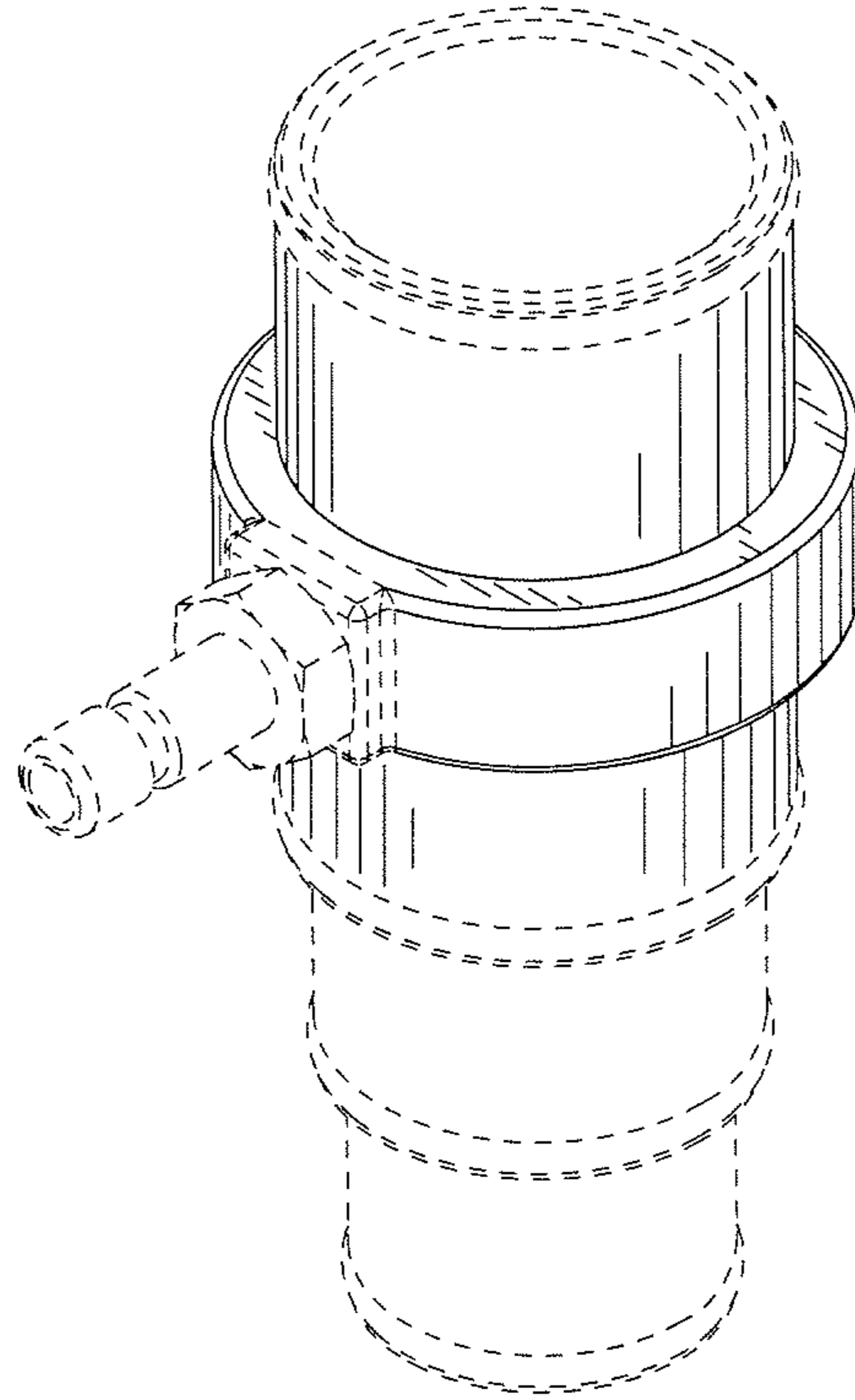

FIG. 1

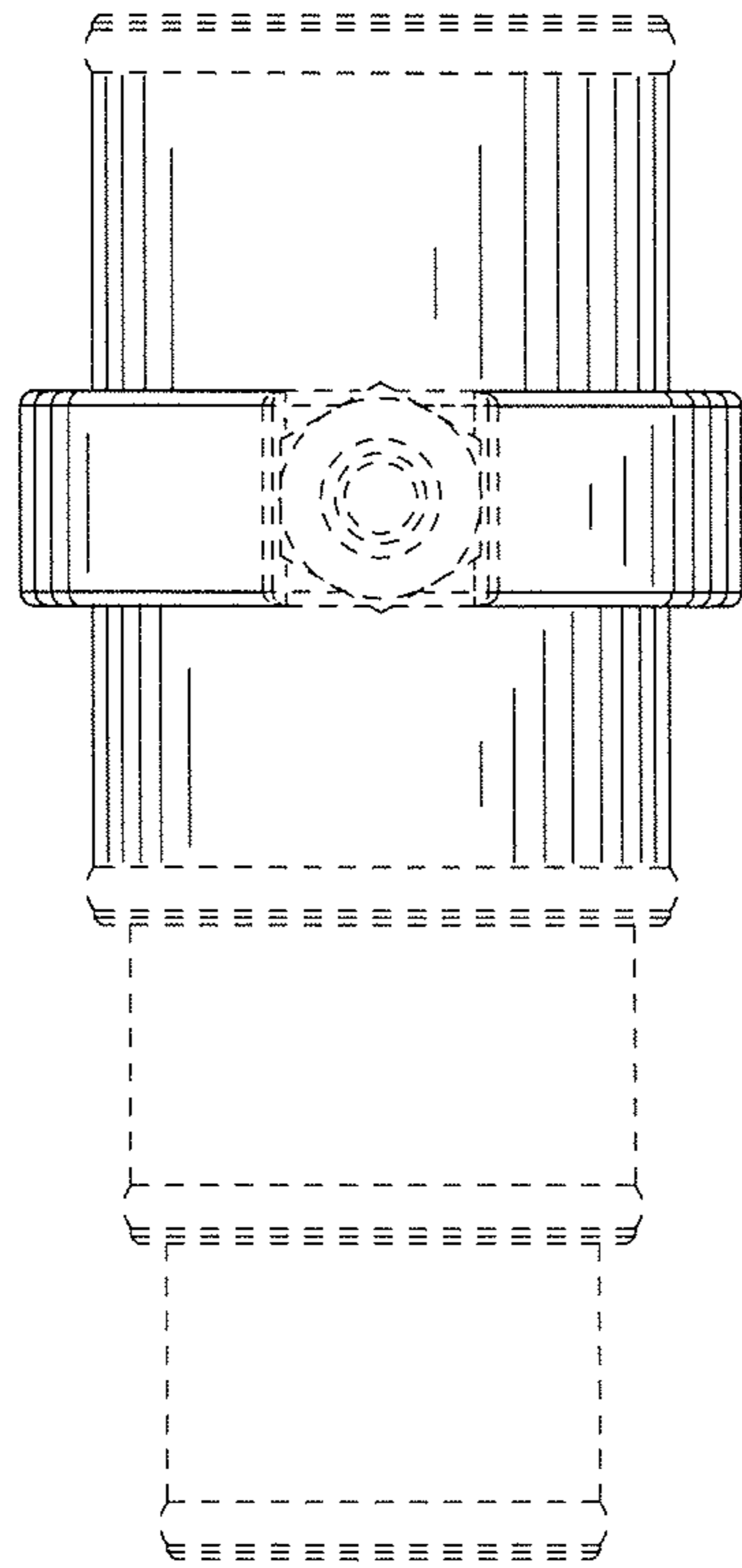

FIG. 2

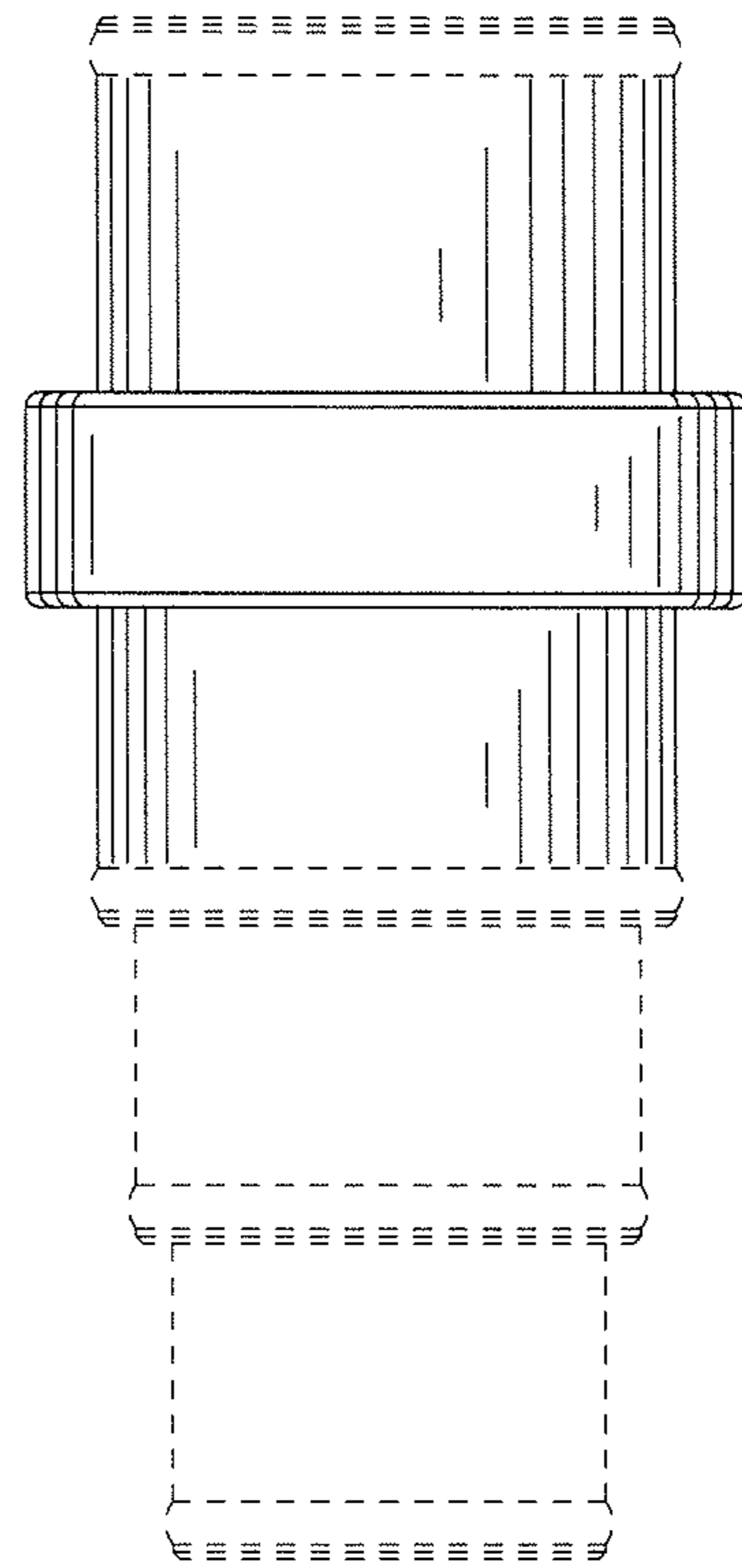

FIG. 3

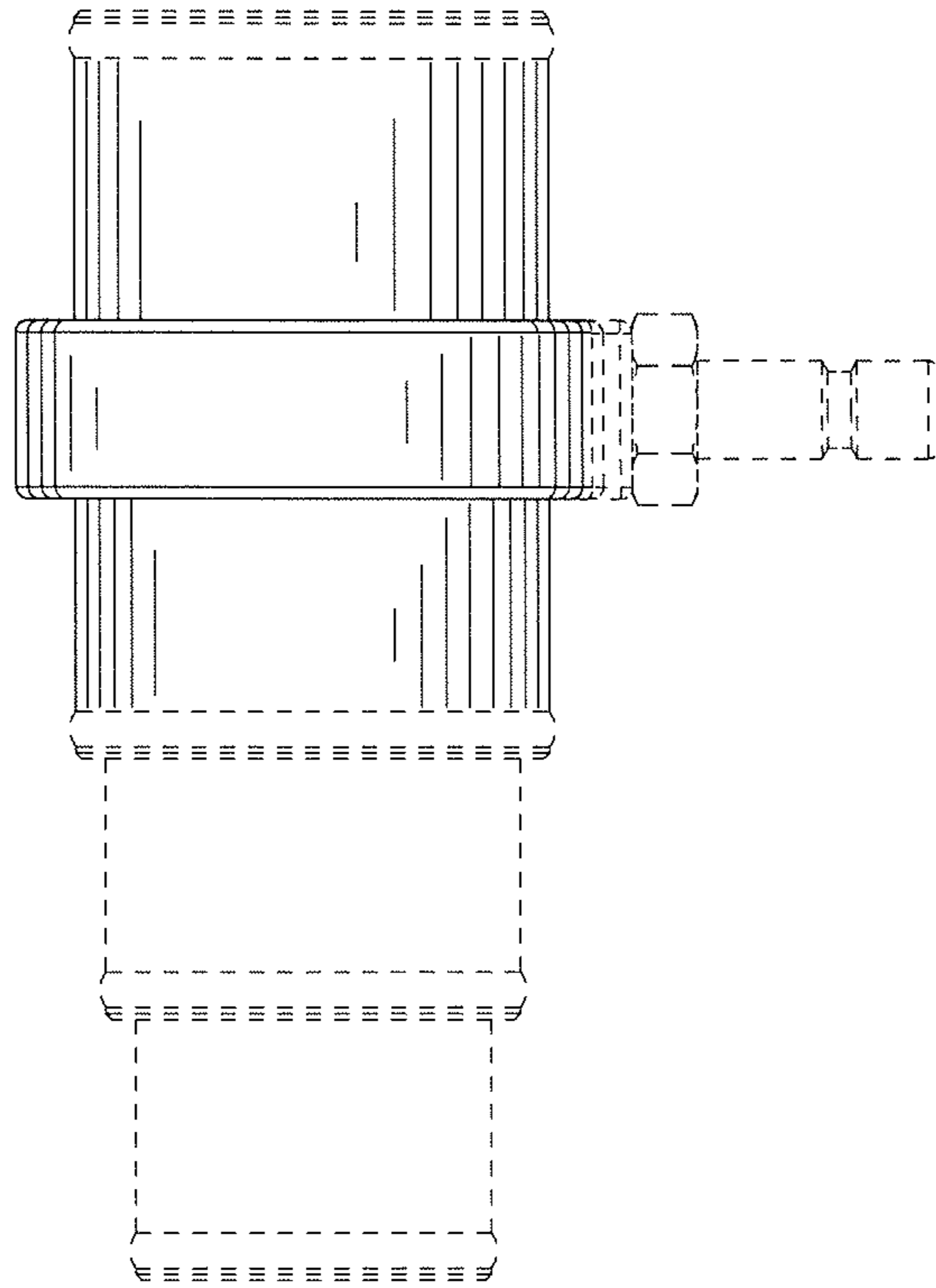

FIG. 4

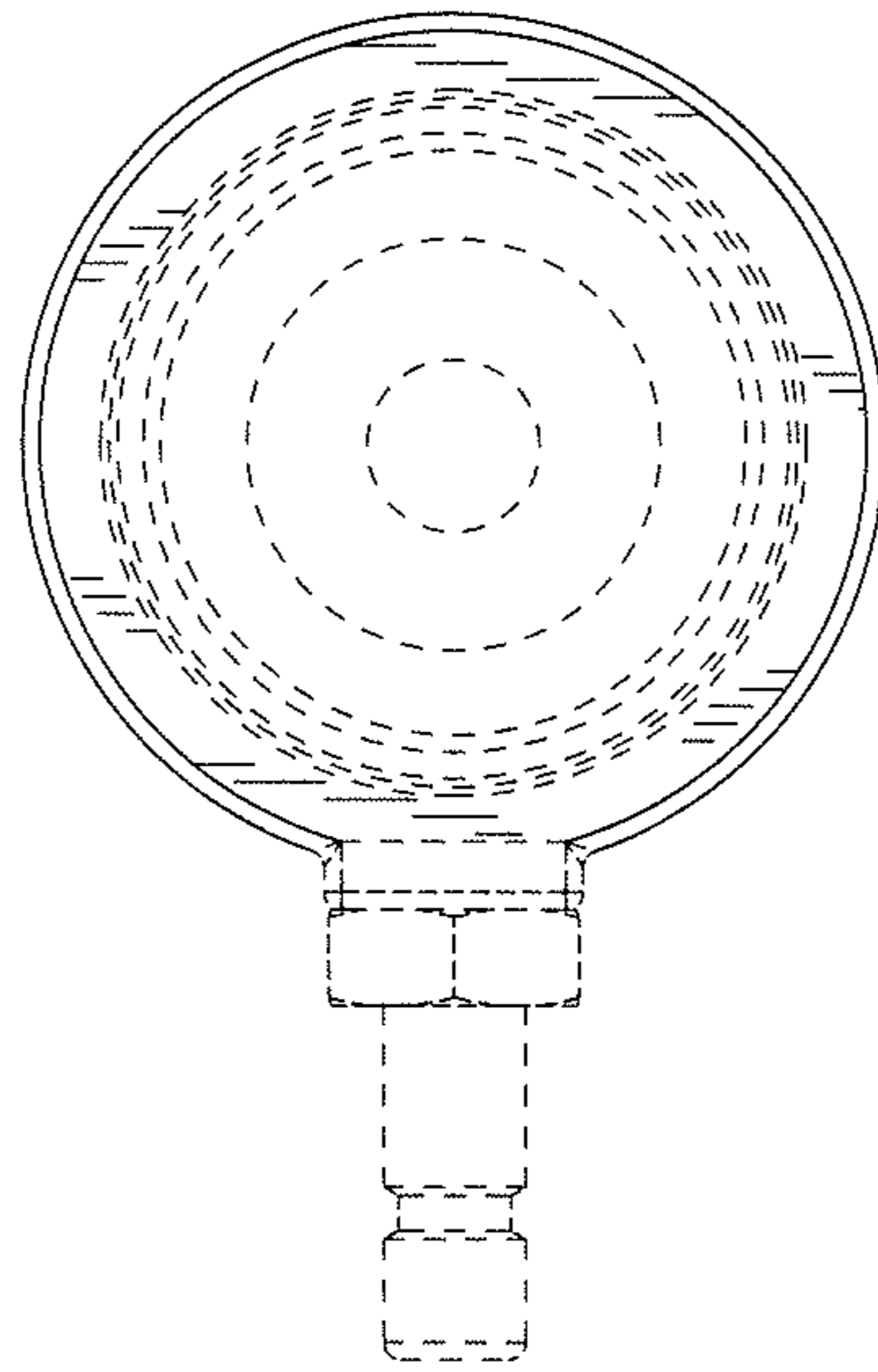

FIG. 5

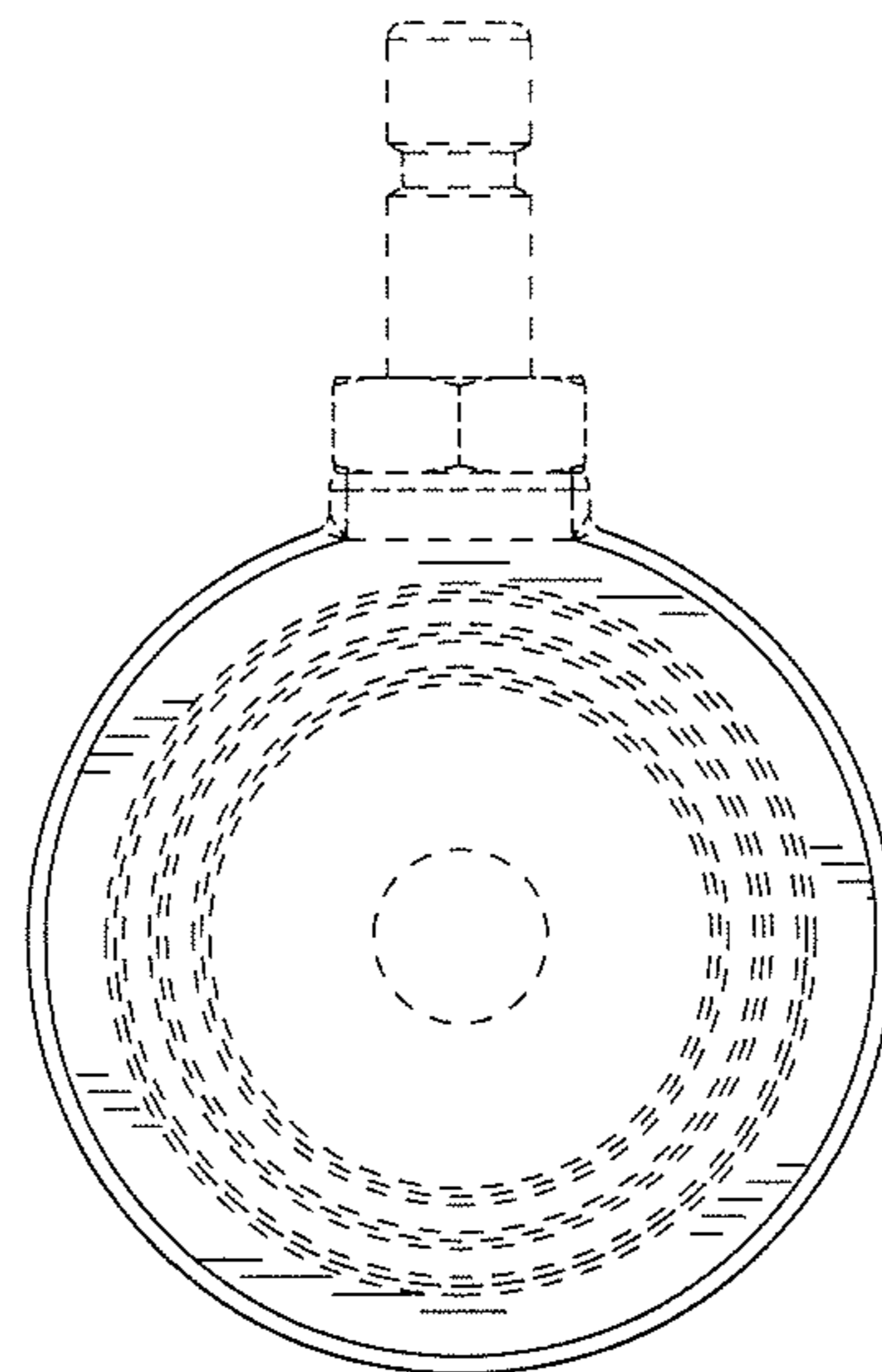

FIG. 6

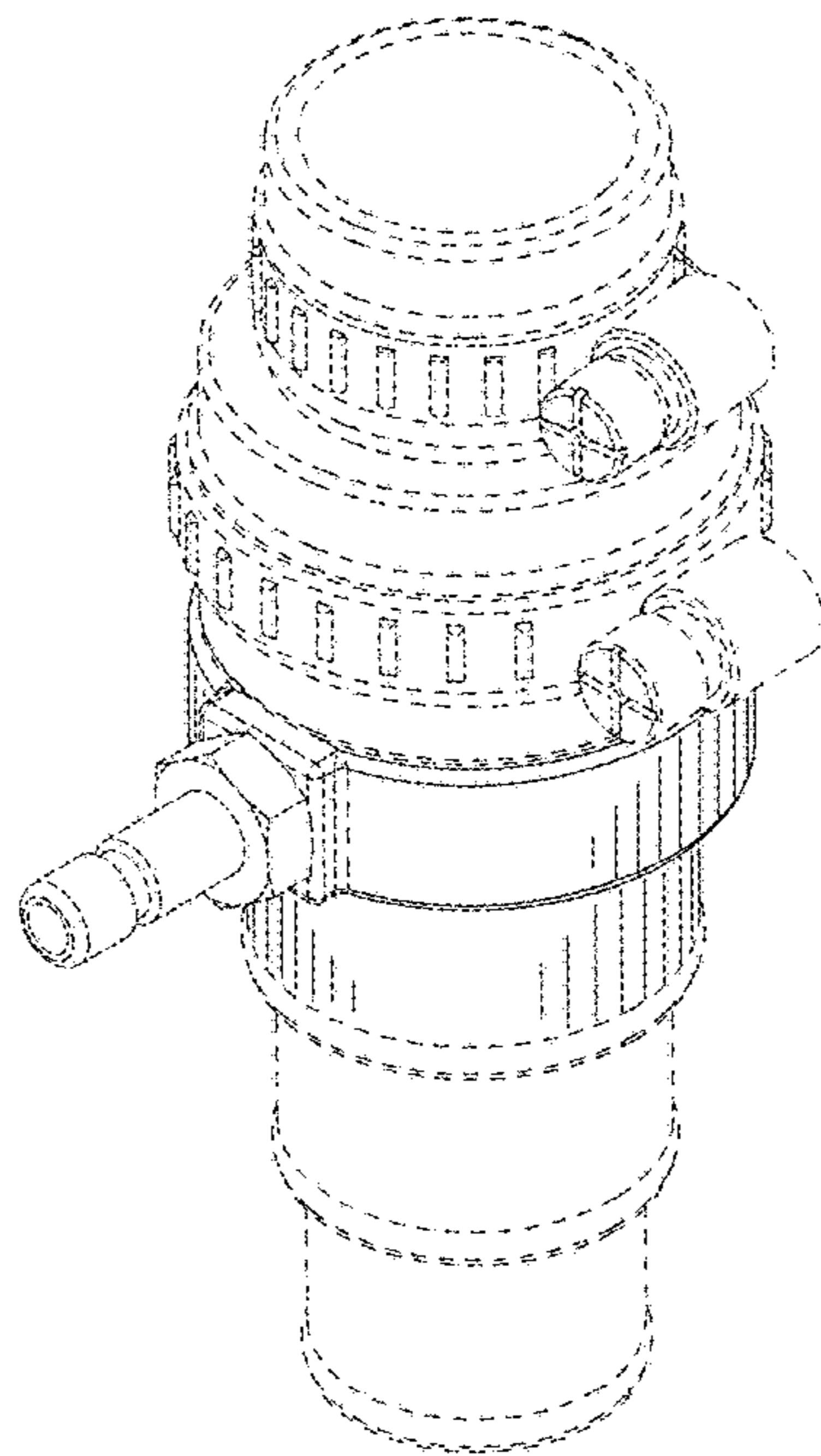

FIG. 7