



US00D802459S

(12) **United States Design Patent** (10) **Patent No.:** **US D802,459 S**
Lemke (45) **Date of Patent:** **** Nov. 14, 2017**

(54) **FLUID FLOW METER**
(71) Applicant: **Agilent Technologies, Inc.**, Santa Clara, CA (US)

5,460,038 A 10/1995 Woodward
5,463,906 A 11/1995 Spani et al.
5,511,416 A 4/1996 Shambayati
(Continued)

(72) Inventor: **Gilbert Lemke**, Los Gatos, CA (US)

FOREIGN PATENT DOCUMENTS

(73) Assignee: **Agilent Technologies, Inc.**, Santa Clara, CA (US)

DE 4319562 A1 2/1995
GB 2353353 A 2/2001
JP 2007086033 A 4/2007

(**) Term: **15 Years**

OTHER PUBLICATIONS

(21) Appl. No.: **29/565,944**

Agilent Flowmeter ADM1000; Operating Instructions; Agilent Technologies, Inc., Third edition, Jun. 2003.

(22) Filed: **May 25, 2016**

(Continued)

(51) **LOC (10) Cl.** **10-04**

Primary Examiner — Antoine D Davis

(52) **U.S. Cl.**

(57) **CLAIM**

USPC **D10/96**

I claim the ornamental design for a fluid flow meter, as shown and described.

(58) **Field of Classification Search**

DESCRIPTION

USPC D10/96

CPC G01F 1/40; G01F 1/42; G01F 1/44; G01F 1/46; G01F 1/74; G01F 11/003; G01F 11/006; G01N 21/03; G01N 21/05; G01N 2021/0378; G01N 2021/0382; G01N 2021/052; G01N 2021/054; G01N 2021/056; G01N 2021/058

FIG. 1 is a front perspective view of a fluid flow meter according to an embodiment.

FIG. 2 is a rear perspective view of the fluid flow meter illustrated in FIG. 1.

FIG. 3 is a top plan view of the fluid flow meter illustrated in FIG. 1.

FIG. 4 is a front elevation view of the fluid flow meter illustrated in FIG. 1.

FIG. 5 is a rear elevation view of the fluid flow meter illustrated in FIG. 1.

FIG. 6 is a bottom plan view of the fluid flow meter illustrated in FIG. 1.

FIG. 7 is a left side view of the fluid flow meter illustrated in FIG. 1; and,

FIG. 8 is a right side view of the fluid flow meter illustrated in FIG. 1.

The dashed lines in various figures are for illustrative purposes only and form no part of the claimed design.

See application file for complete search history.

(56) **References Cited**

U.S. PATENT DOCUMENTS

D215,562 S * 10/1969 Sato D10/78
3,925,692 A 12/1975 Leschek et al.
4,303,376 A 12/1981 Siekmann
4,487,062 A 12/1984 Olin et al.
4,800,754 A 1/1989 Korpi
4,979,641 A * 12/1990 Turner B67D 1/0855
222/153.03
5,022,557 A * 6/1991 Turner B67D 1/0855
222/54
5,297,427 A 3/1994 Shambayati
5,447,073 A 9/1995 Kalinoski

1 Claim, 5 Drawing Sheets

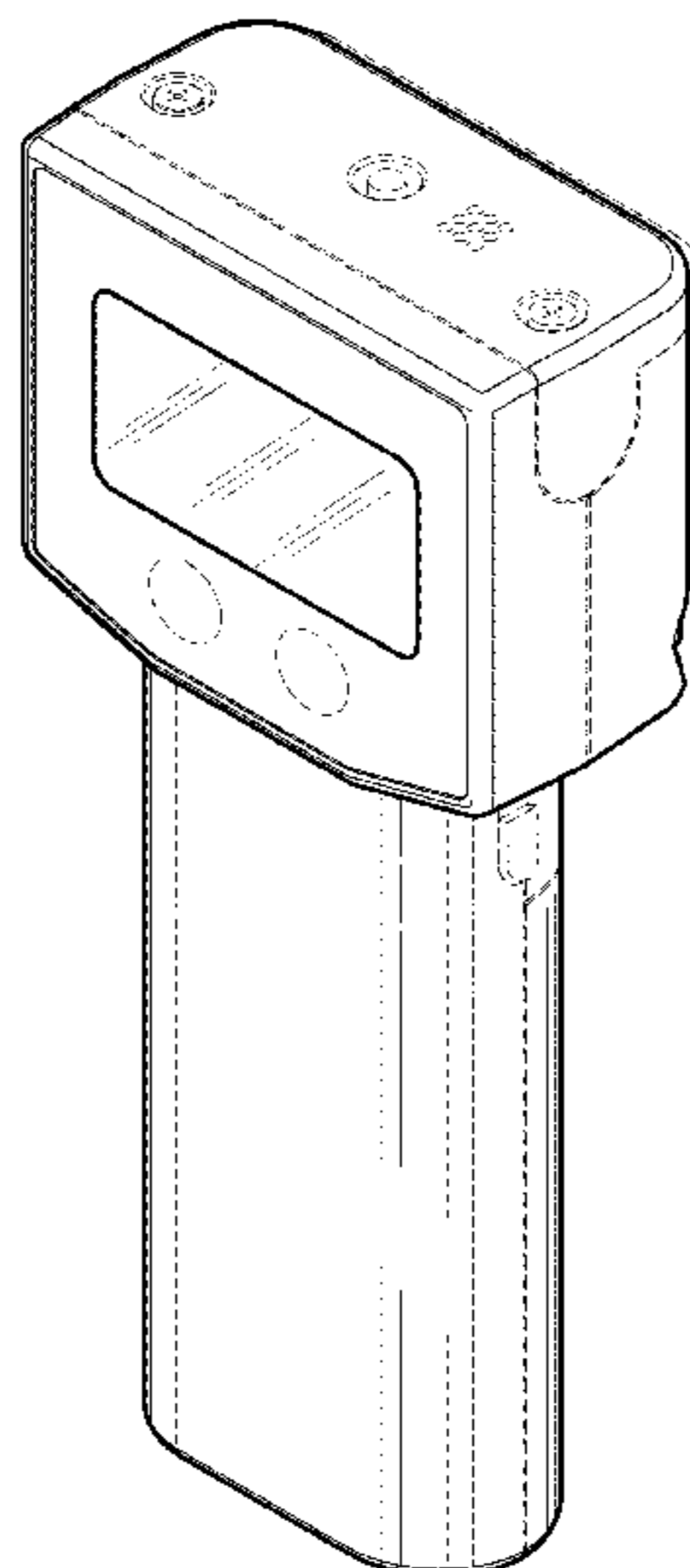

(56)

References Cited

U.S. PATENT DOCUMENTS

5,526,674	A	6/1996	Korpi
5,684,246	A	11/1997	Korpi
5,723,783	A	3/1998	Woodward
5,780,736	A	7/1998	Russell
7,845,239	B1	12/2010	Lam
8,048,022	B2	11/2011	Moy et al.
8,262,992	B2	9/2012	Kontschieder et al.
8,438,933	B2	5/2013	Grove et al.
2008/0195020	A1	8/2008	Cabuz et al.
2010/0300213	A1	12/2010	Fink et al.
2013/0124131	A1	5/2013	Murakami

OTHER PUBLICATIONS

Agilent Flowmeter ADM2000; Operating Instructions; Agilent Technologies Inc., Third edition, Jun. 2003.

Restek's ProFLOW 6000 Electronic Flowmeter; Users Manual Version 5.6 for cat.#22656; Restek; Apr. 2014.

International Search Report and Written Opinion dated Jun. 13, 2017 from related International Application No. PCT/US2017/023219.

* cited by examiner

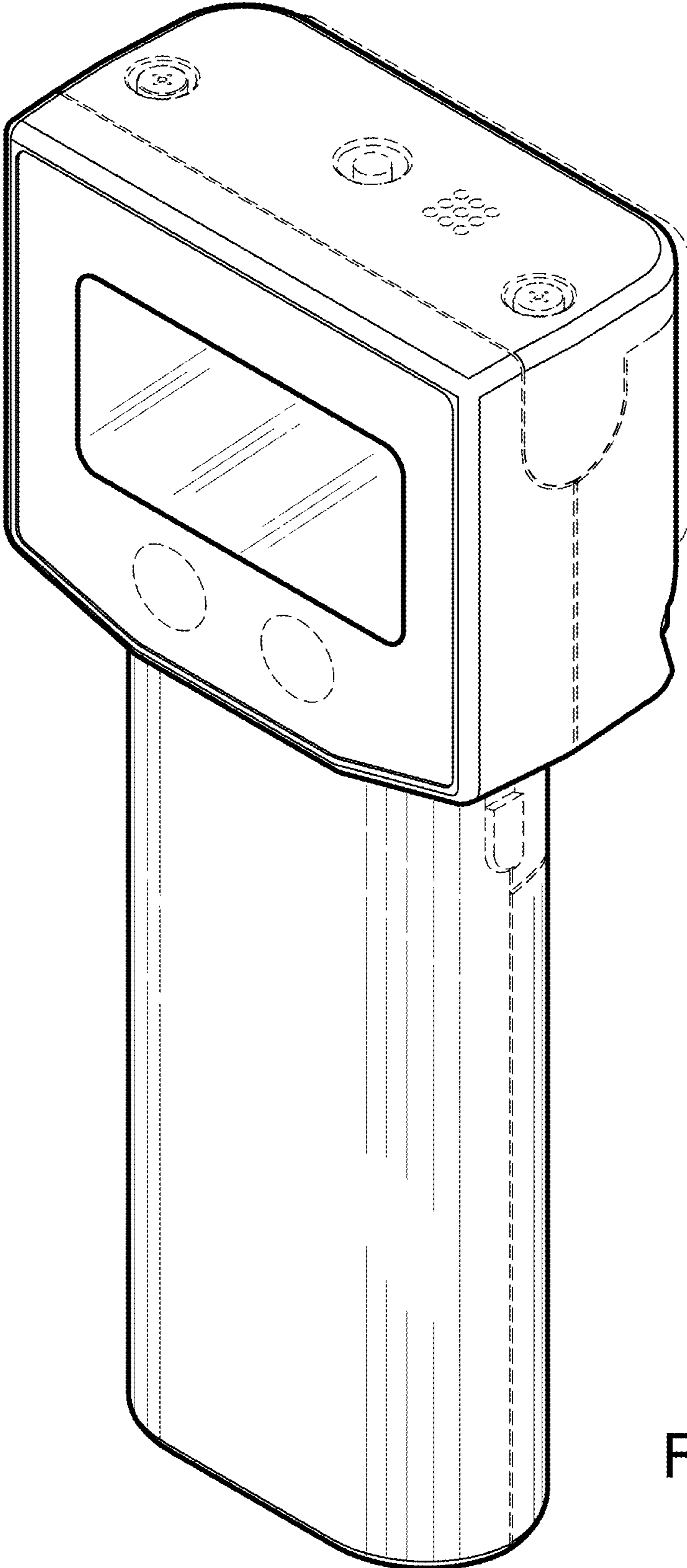

FIG. 1

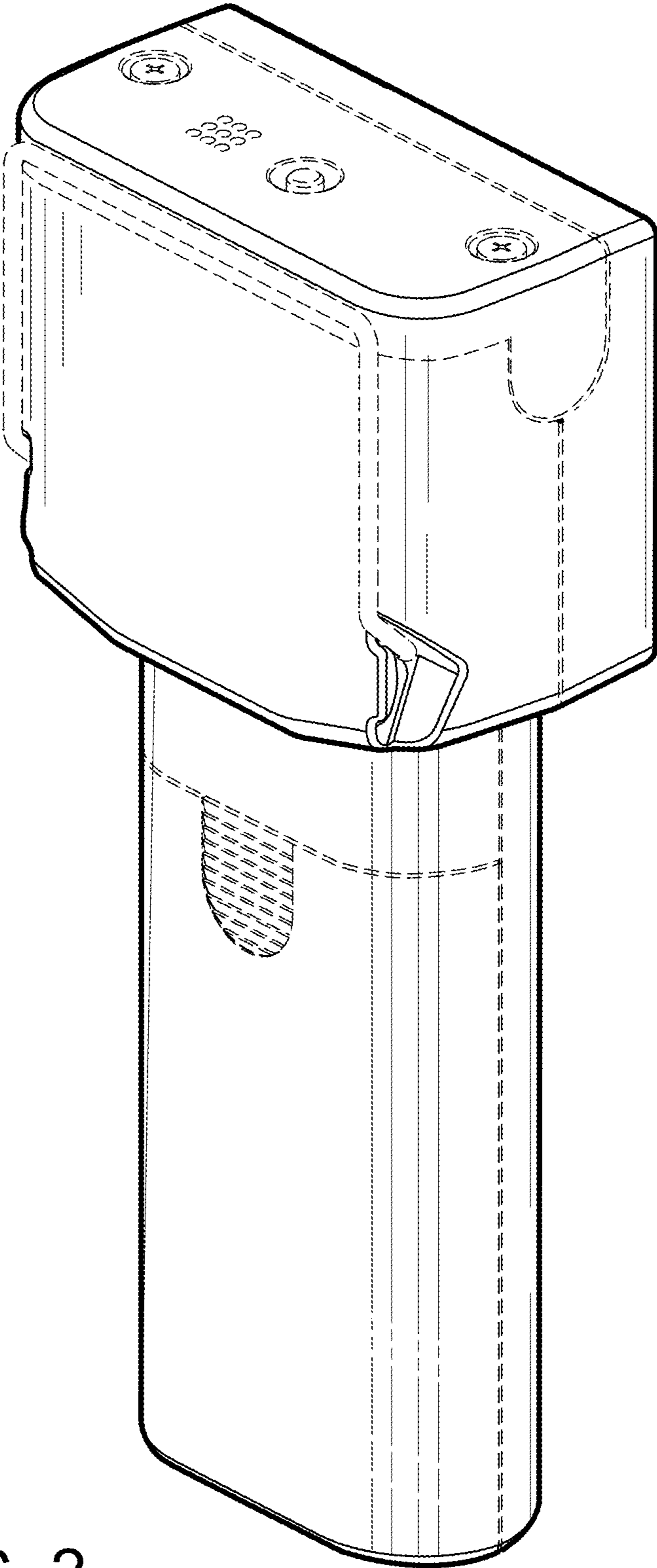

FIG. 2

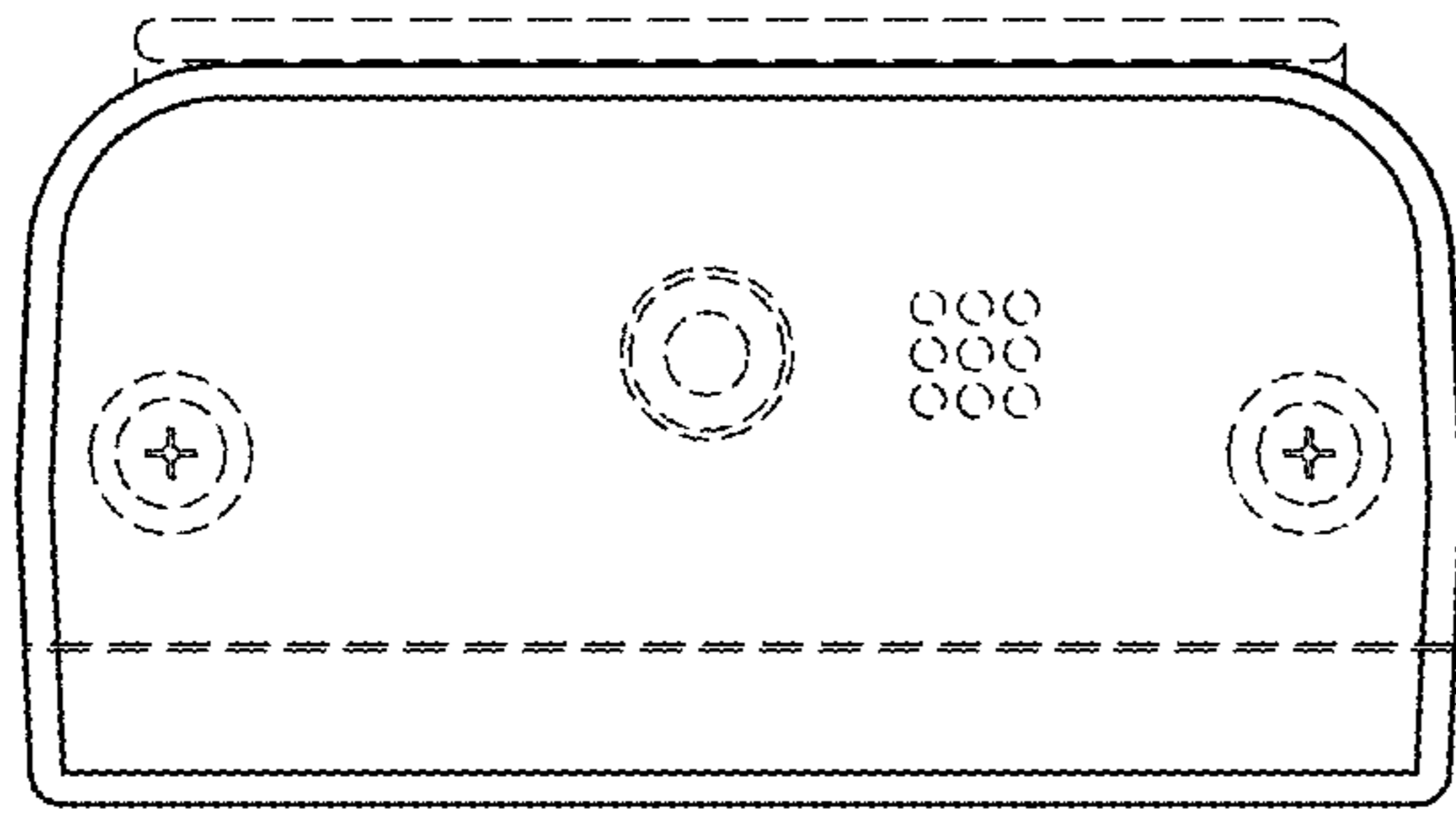

FIG. 3

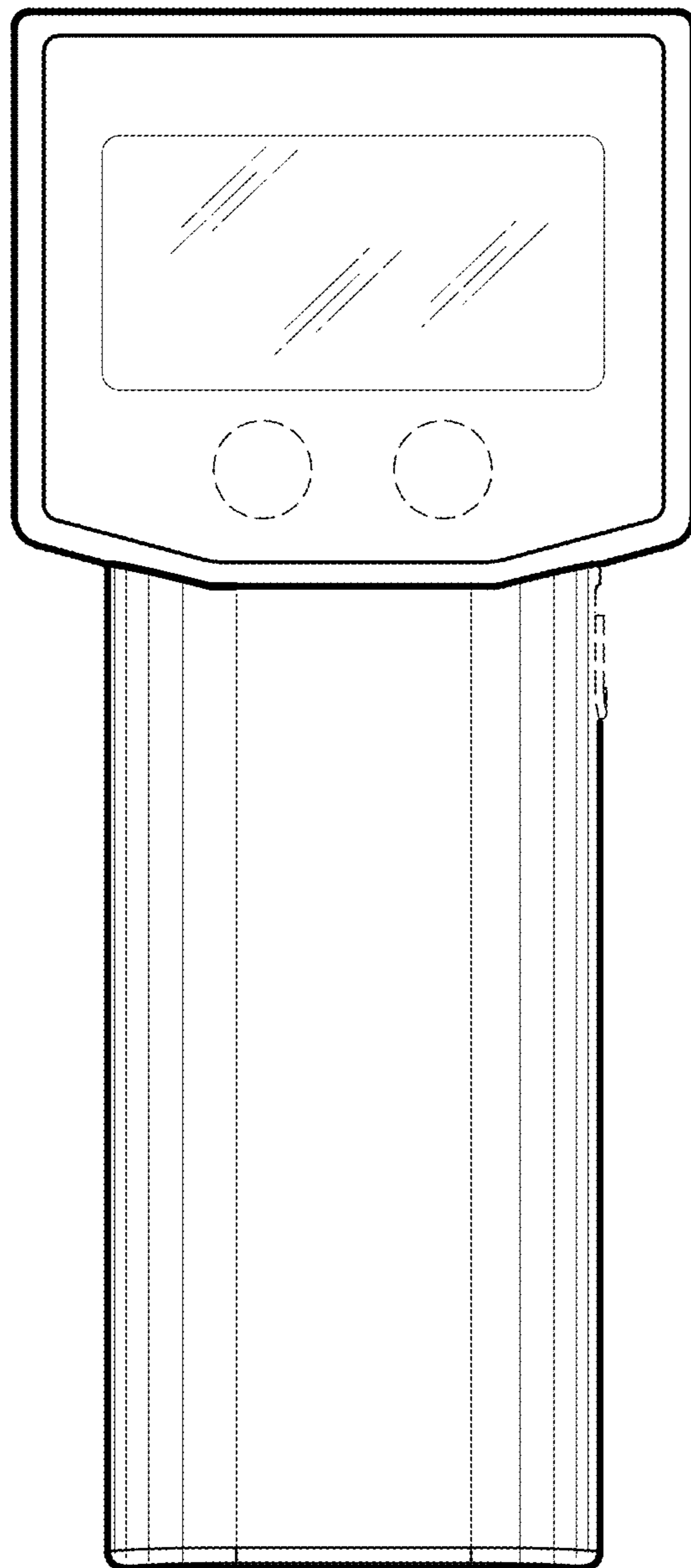

FIG. 4

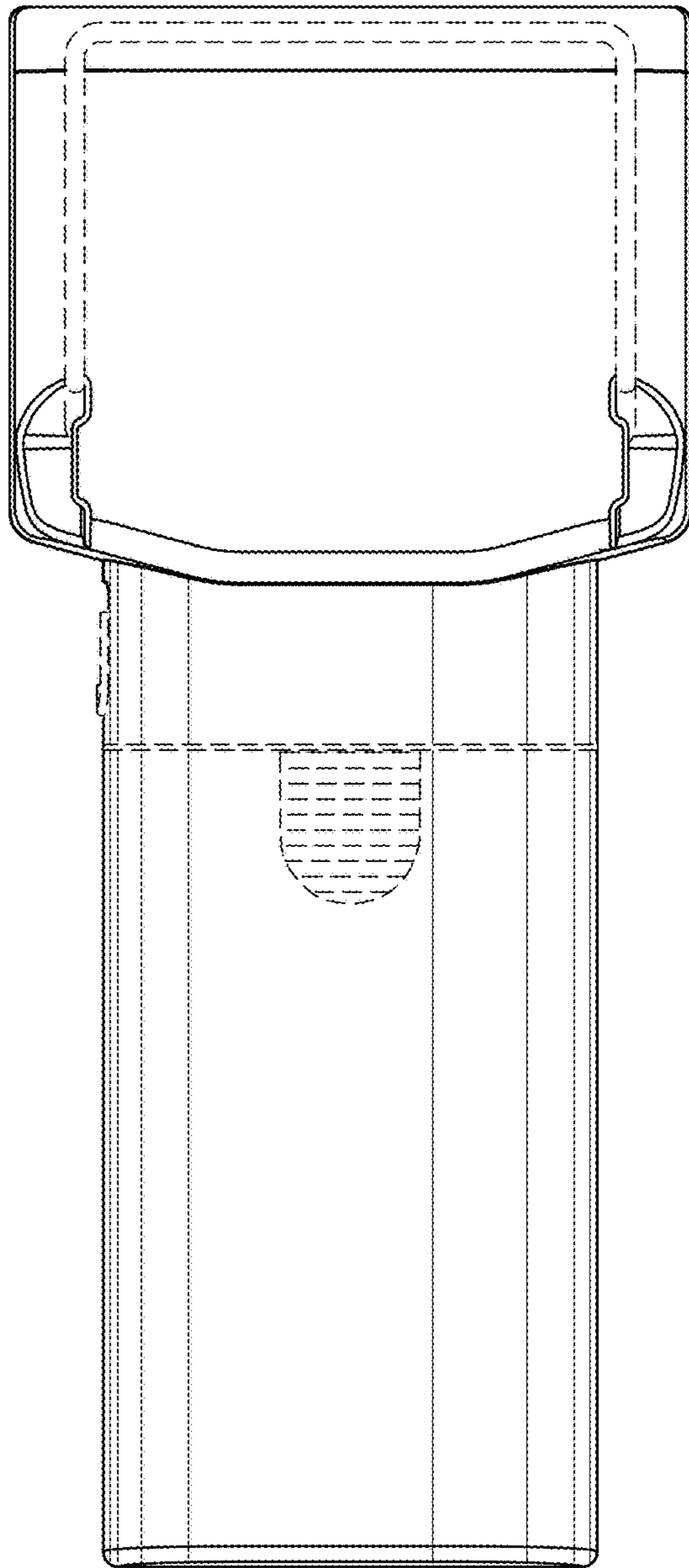

FIG. 5

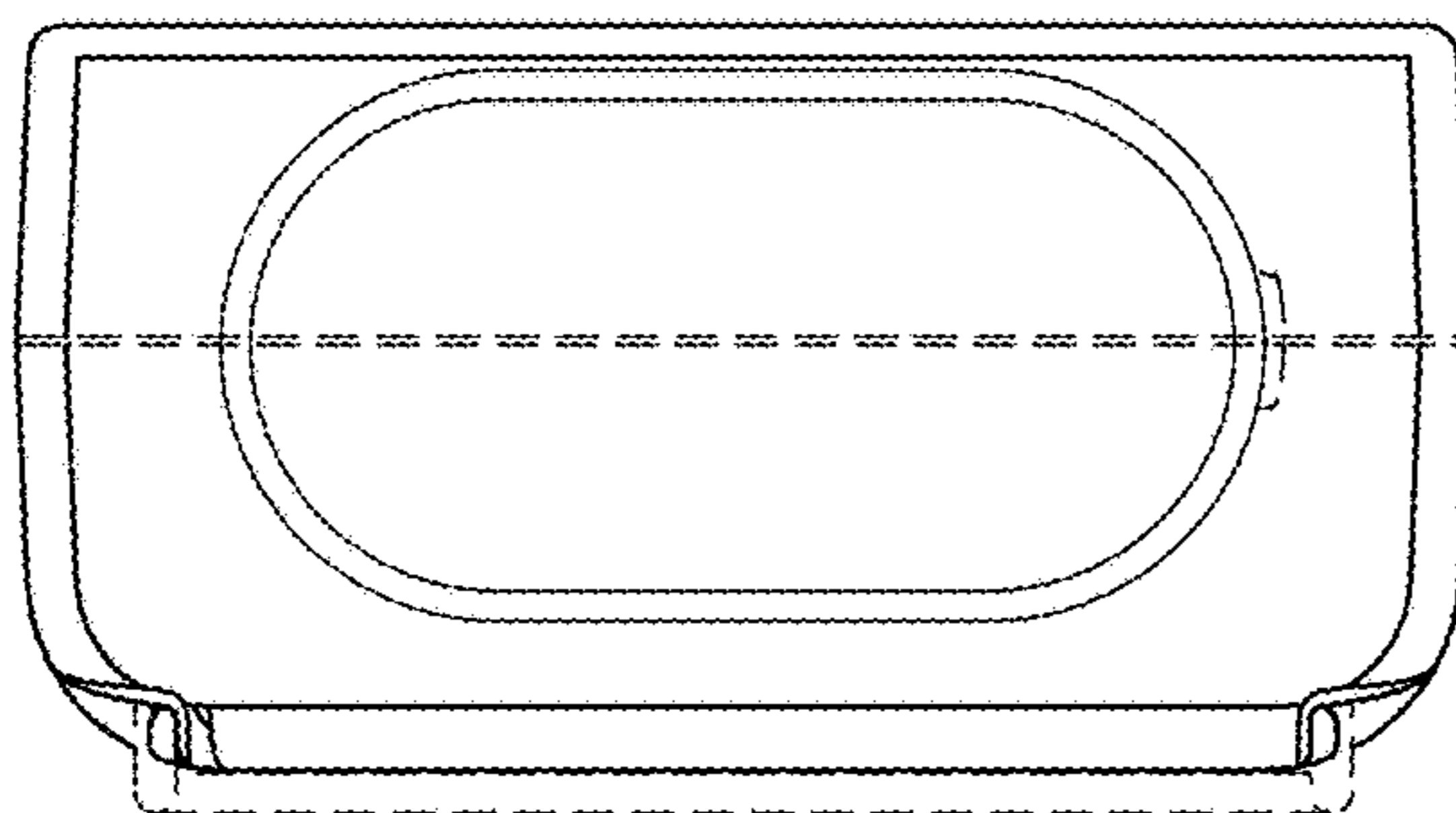

FIG. 6

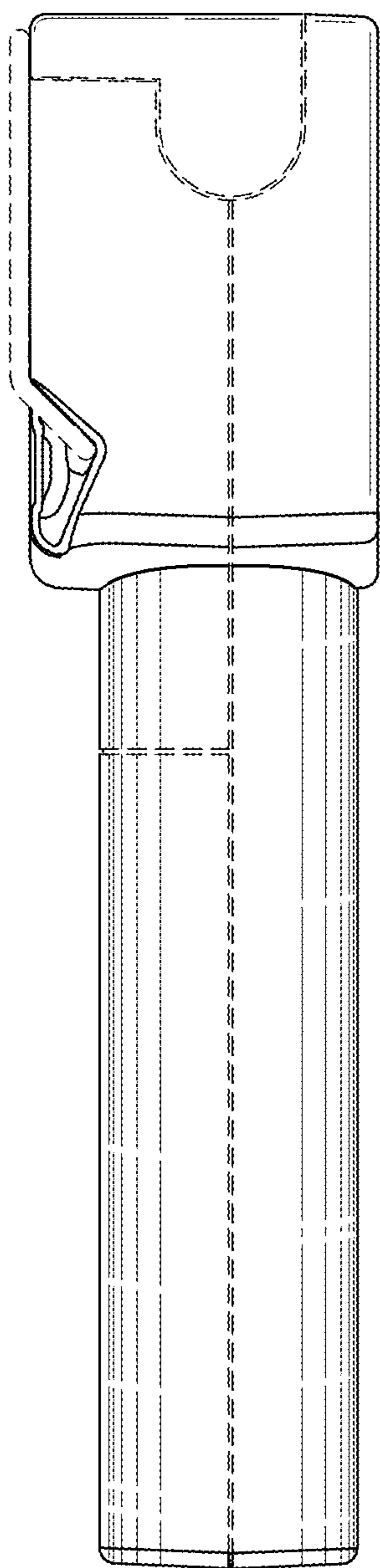

FIG. 7

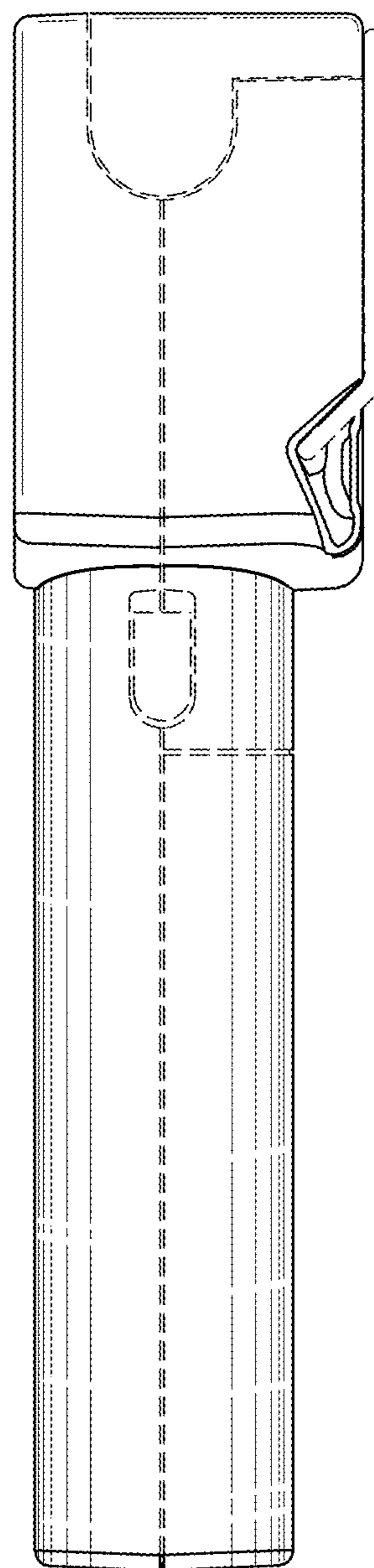

FIG. 8