



US00D802419S

(12) **United States Design Patent** (10) **Patent No.:** **US D802,419 S**  
**Seiders et al.** (45) **Date of Patent:** **\*\* Nov. 14, 2017**

(54) **LID**  
(71) Applicant: **YETI Coolers, LLC**, Austin, TX (US)  
(72) Inventors: **Roy Joseph Seiders**, Austin, TX (US);  
**John Alan Tolman**, Austin, TX (US);  
**Steve Nichols**, Austin, TX (US)  
(73) Assignee: **YETI Coolers, LLC**, Austin, TX (US)  
(\*\*) Term: **15 Years**

D279,346 S 6/1985 Ruxton  
D281,567 S 12/1985 Zimmermann  
D286,604 S 11/1986 Bierlein et al.  
(Continued)

FOREIGN PATENT DOCUMENTS

CN 301110494 1/2010  
CN 303528321 12/2015  
(Continued)

OTHER PUBLICATIONS

“First Look: YETI Rambler One Gallon ‘Jug’ Review”. Found online Jun. 12, 2017 at gearjunkie.com. Page dated May 2, 2017. Retrieved from <https://gearjunkie.com/yeti-rambler-one-gallon-jug-review>.\*

(Continued)

*Primary Examiner* — Robert M Spear  
*Assistant Examiner* — Kendra L Hamilton  
(74) *Attorney, Agent, or Firm* — Banner & Witcoff, Ltd.

(21) Appl. No.: **29/546,309**  
(22) Filed: **Nov. 20, 2015**  
(51) **LOC (10) Cl.** ..... **09-07**  
(52) **U.S. Cl.**  
USPC ..... **D9/447**; D7/392.1  
(58) **Field of Classification Search**  
USPC ..... D7/391, 392, 392.1, 396.1, 396.2, 397,  
D7/398, 509, 510, 511, 543; D9/435,  
D9/436, 438, 447, 449, 450  
CPC ..... B65D 47/122; B65D 41/04; B65D  
2543/0092  
See application file for complete search history.

(57) **CLAIM**  
The ornamental design for a lid, as shown and described.

**DESCRIPTION**

FIG. 1 is a top, front, left perspective view of a lid showing our new design;  
FIG. 2 is a front view thereof;  
FIG. 3 is a rear view thereof;  
FIG. 4 is a right side view thereof;  
FIG. 5 is a left side view thereof;  
FIG. 6 is a top view thereof; and,  
FIG. 7 is a bottom view thereof.  
The broken lines immediately adjacent to the shaded area represent unclaimed boundaries of the design. The broken lines showing the remainder of the lid are for environmental purposes only and form no part of the claimed design.

(56) **References Cited**  
U.S. PATENT DOCUMENTS

1,477,936 A	12/1923	Bott
D109,331 S	4/1938	McManus et al.
D154,378 S	7/1949	Fuller
D177,761 S	5/1956	Reinhardt
2,957,596 A	10/1960	Rehborg
2,963,187 A	12/1960	Bramming
3,089,603 A	5/1963	Leslie-Smith
3,239,090 A	3/1966	Bramming
D224,646 S	8/1972	Vollquartz
3,752,347 A	8/1973	Bell
D235,303 S	6/1975	Boucher
D248,373 S	7/1978	Allen
D256,651 S	9/1980	Leung et al.

**1 Claim, 4 Drawing Sheets**

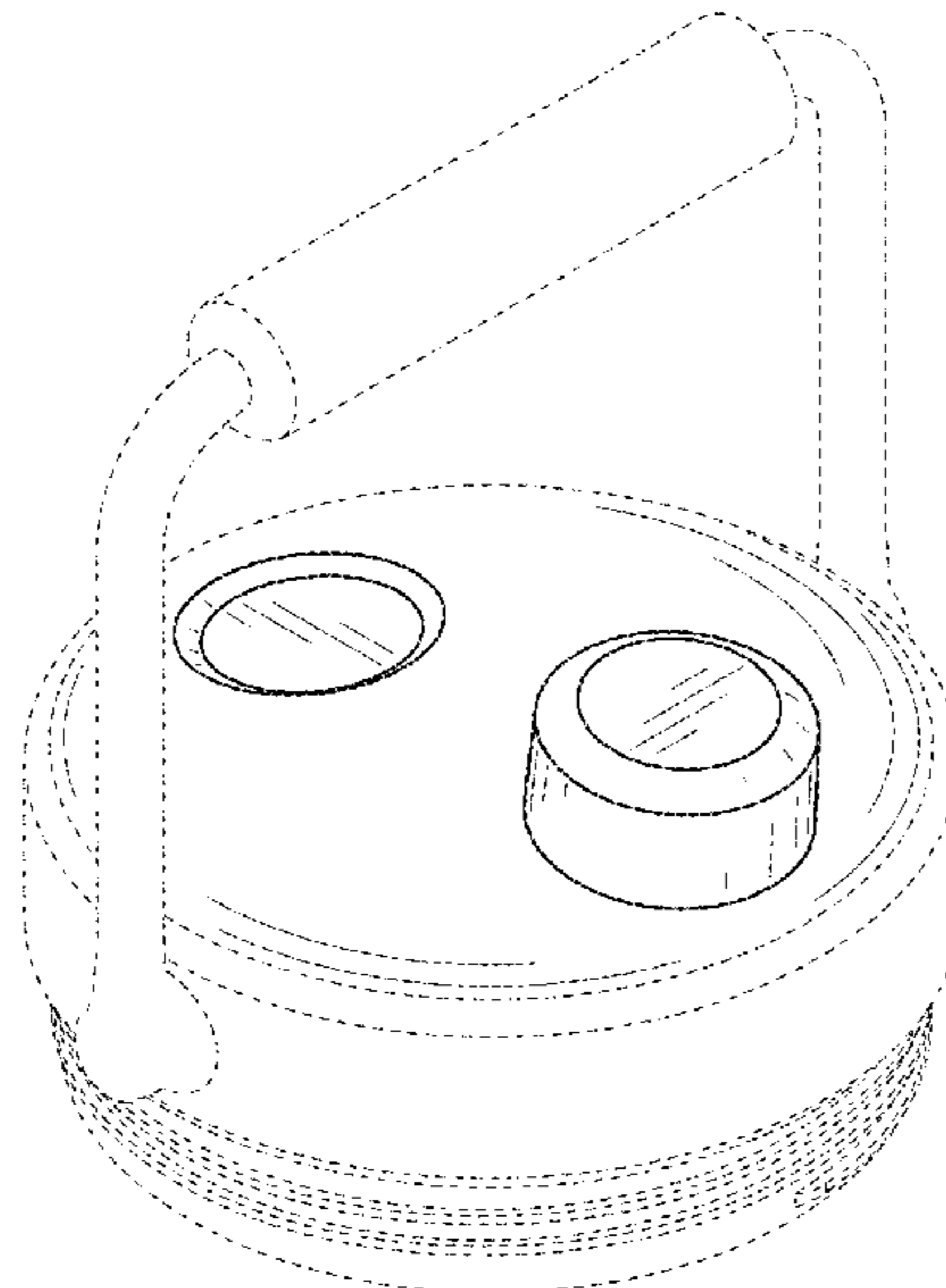

(56)

References Cited

U.S. PATENT DOCUMENTS

D286,847 S	11/1986	Zimmermann	D629,691 S	12/2010	Cresswell et al.
D287,211 S	12/1986	Weiss	D630,474 S	1/2011	Gilbert
D321,628 S	11/1991	Kobayashi et al.	D630,475 S	1/2011	Lu
D332,379 S *	1/1993	Murphy ..... D7/391	D631,666 S	2/2011	Lim et al.
5,232,112 A	8/1993	Howard	D633,338 S	3/2011	Rosbach et al.
D354,915 S	1/1995	Schneider et al.	D633,794 S	3/2011	Cresswell et al.
D368,224 S *	3/1996	Arndt ..... D9/436	D633,795 S	3/2011	Cresswell et al.
D384,280 S *	9/1997	Kuczer ..... D9/436	D633,796 S	3/2011	Cresswell et al.
D398,193 S	9/1998	Sanchez	D633,797 S	3/2011	Cresswell et al.
5,813,557 A	9/1998	Oratz	D634,160 S	3/2011	Cetera
D405,650 S	2/1999	Meier	D635,457 S	4/2011	Lane
D415,395 S	10/1999	Hunt et al.	D635,856 S	4/2011	Lauret
D422,916 S	4/2000	Herrmann	D638,695 S	5/2011	Woodrow et al.
6,264,072 B1	7/2001	Johannes	D638,708 S	5/2011	Walsh
6,332,557 B1	12/2001	Moran	D639,164 S	6/2011	Walsh
D456,669 S	5/2002	Munari	D639,661 S	6/2011	Llerena
D458,133 S	6/2002	Berish et al.	D639,663 S	6/2011	Llerena
D458,134 S	6/2002	Berish et al.	D641,591 S	7/2011	Tsukida
D466,814 S	12/2002	Hurlburt	D643,693 S	8/2011	Jama
D479,800 S	9/2003	McRae	D648,984 S	11/2011	Gullickson et al.
D482,607 S	11/2003	McRae	D651,847 S *	1/2012	Gilbert ..... D7/392.1
D494,425 S	8/2004	Segura	D652,255 S	1/2012	Carland
D524,909 S	7/2006	Bakke et al.	D652,682 S	1/2012	Eyal
D525,518 S	7/2006	Baldwin	D654,762 S	2/2012	Gilbert
D530,141 S	10/2006	Wilgus et al.	D655,134 S	3/2012	Gilbert
D536,929 S	2/2007	Kingsley	D655,581 S	3/2012	Kotani
7,172,101 B2	2/2007	Find	D657,196 S	4/2012	Beyers, III
D548,082 S	8/2007	Kingsley	D658,064 S	4/2012	Barnes et al.
D549,444 S	8/2007	Schnackenberg	D658,445 S	5/2012	Carreno
7,270,244 B1	9/2007	Liu	D659,007 S	5/2012	Pape
D553,914 S	10/2007	Wahl	D660,084 S	5/2012	Gilbert
D554,000 S	10/2007	Walsh	D662,360 S	6/2012	George
D564,363 S	3/2008	Rhea	8,210,572 B2	7/2012	Davis
D572,585 S	7/2008	Perrin et al.	8,215,511 B1	7/2012	Lin
D574,237 S *	8/2008	Yates, III ..... D9/447	D664,809 S	8/2012	Eyal
D584,623 S	1/2009	Chupak	D665,621 S	8/2012	Eyal
D586,183 S	2/2009	Junkel	8,245,600 B2	8/2012	Beard
D587,533 S	3/2009	Carreno	D668,913 S	10/2012	Mayer
D601,436 S	10/2009	Stephens et al.	D671,372 S	11/2012	Zou
D603,331 S	11/2009	Schupp	D672,238 S	12/2012	Aziz et al.
D603,722 S	11/2009	Reimer	D672,609 S	12/2012	Aziz et al.
D604,181 S	11/2009	Reimer	D675,100 S	1/2013	Herbst
D604,561 S	11/2009	Chisholm	D676,764 S	2/2013	Moore et al.
D605,040 S	12/2009	Fry et al.	D678,729 S	3/2013	Peeters et al.
D605,060 S	12/2009	Reimer	D678,772 S	3/2013	Johnson et al.
D610,871 S	3/2010	Alviar et al.	D680,389 S	4/2013	Zemel et al.
D611,346 S	3/2010	Camomile	8,443,993 B1	5/2013	Desselle
D612,235 S	3/2010	Cresswell et al.	8,443,994 B1	5/2013	Desselle
D614,918 S	5/2010	Chisholm	D684,059 S	6/2013	Johnson et al.
D615,360 S	5/2010	Joy et al.	D686,078 S	7/2013	Johnson et al.
D615,361 S	5/2010	Goble	D688,093 S	8/2013	Roth et al.
D615,816 S	5/2010	Joy et al.	8,505,787 B2	8/2013	Fox et al.
D616,703 S	6/2010	Joy et al.	D690,987 S *	10/2013	Gallen ..... D7/392.1
D616,743 S	6/2010	Cresswell et al.	D693,698 S	11/2013	Miller, Jr.
D616,744 S	6/2010	Cresswell et al.	D695,138 S	12/2013	Ball
D619,457 S	7/2010	Walsh	8,613,369 B2	12/2013	Kitto
D619,458 S	7/2010	Walsh	D696,945 S	1/2014	Newman
D619,459 S	7/2010	Walsh	D697,404 S	1/2014	Johnson et al.
D620,798 S	8/2010	Cresswell et al.	D697,802 S	1/2014	Lane
D621,257 S	8/2010	Gullickson et al.	D698,668 S	2/2014	Vaughn
D621,258 S	8/2010	Gullickson et al.	D701,464 S	3/2014	Ogata et al.
D622,089 S	8/2010	Daniel et al.	D702,092 S	4/2014	Mettler et al.
D622,145 S	8/2010	Walsh	D702,506 S	4/2014	Mettler et al.
D623,475 S	9/2010	Aarnoudse et al.	8,701,881 B2	4/2014	Gibson et al.
D623,480 S	9/2010	Moran	8,701,924 B2	4/2014	Dalbec
D625,560 S	10/2010	Olson et al.	D708,954 S	7/2014	Barnes et al.
D626,414 S	11/2010	Cresswell et al.	D709,734 S	7/2014	Kotani
D626,416 S	11/2010	Cresswell et al.	D712,254 S	9/2014	Geis et al.
D627,601 S	11/2010	Eyal	D712,255 S	9/2014	Geis et al.
D627,602 S	11/2010	Eyal	D713,268 S	9/2014	Jones et al.
D627,604 S	11/2010	Eyal	D713,365 S	9/2014	Green
D628,018 S	11/2010	Gilbert	D717,102 S	11/2014	Taketani et al.
D628,486 S	12/2010	Lane	8,905,252 B2 *	12/2014	Latham ..... B65D 51/18 215/228
D629,689 S	12/2010	Cresswell et al.	D724,385 S	3/2015	Hurley et al.
D629,690 S	12/2010	Cresswell et al.	D728,315 S	5/2015	Bo
			D728,995 S	5/2015	Barberi
			D729,579 S	5/2015	Molayem
			D729,584 S	5/2015	Weston et al.

(56)

References Cited

U.S. PATENT DOCUMENTS

D732,402	S	6/2015	Jones et al.	
D734,154	S	7/2015	Johnson et al.	
D735,578	S	8/2015	Mazurkiewicz et al.	
D741,655	S	10/2015	Whelan et al.	
D743,742	S	11/2015	Rummel et al.	
D744,781	S	12/2015	Rummel et al.	
D754,472	S	4/2016	Munari	
D755,561	S *	5/2016	Eyal .....	D7/392.1
D758,790	S	6/2016	Boroski	
D758,791	S *	6/2016	Hanna .....	D7/392.1
D762,418	S *	8/2016	Sorensen .....	D7/511
D763,076	S	8/2016	Lane et al.	
2010/0089151	A1	4/2010	Mantilla et al.	
2011/0186585	A1	8/2011	Lu	
2012/0199548	A1	8/2012	Kitto	
2014/0069917	A1 *	3/2014	Meyers .....	B65D 21/022 220/23.88
2014/0251938	A1 *	9/2014	Rose .....	B65D 51/28 215/6
2014/0353275	A1	12/2014	Hung	
2015/0191293	A1	7/2015	Forcella	
2015/0251812	A1	9/2015	Gillie	
2015/0314929	A1	11/2015	Tebbe et al.	
2016/0176587	A1	6/2016	Heraud	
2016/0318693	A1 *	11/2016	Hein .....	B65D 41/0442

FOREIGN PATENT DOCUMENTS

FR	2786465	6/2000
JP	2001315831 A	11/2001
JP	1363566	6/2009
JP	1530358	8/2015
KR	300295354	4/2002
KR	300303813.0000	8/2002
KR	300751936.0000	7/2014
KR	300764889.0000	10/2014
WO	2005028317 A2	3/2005
WO	2006023238 A2	3/2006
WO	0088688-002	1/2016

OTHER PUBLICATIONS

“Lifefactory Water Bottle with Flip Cap”. Found online Oct. 26, 2016 at amazon.com. Page dated Jan. 21, 2012. Retrieved from [https://www.amazon.com/Lifefactory-22-Ounce-BPA-Free-Bottle-Silicone/dp/B01JIHJYOI/ref=pd\\_day0\\_79\\_22?\\_encoding=UTF8&refRID=YW47QZQ73YFSYXXEHXG2](https://www.amazon.com/Lifefactory-22-Ounce-BPA-Free-Bottle-Silicone/dp/B01JIHJYOI/ref=pd_day0_79_22?_encoding=UTF8&refRID=YW47QZQ73YFSYXXEHXG2).\*

“Igloo Sport Beverage Cooler”. Found online Jun. 7, 2017 at amazon.com. Page dated Mar. 9, 2013. Retrieved from [https://www.amazon.com/Igloo-Beverage-Cooler-Majestic-2-Gallon/dp/B0088AYPOG/ref=cm\\_cr\\_ar\\_p\\_d\\_product\\_top?ie=UTF8](https://www.amazon.com/Igloo-Beverage-Cooler-Majestic-2-Gallon/dp/B0088AYPOG/ref=cm_cr_ar_p_d_product_top?ie=UTF8).\*

“Klear Loop Cap Hangle Lids for Klear Bottle and Hydro Flask”. Found online Jun. 7, 2017 at amazon.com. Page dated Jul. 4, 2016.

Retrieved from [https://www.amazon.com/Klear-Handle-Bottle-Hydro-Flask/dp/B01EXKSRLQ/ref=cm\\_cr\\_ar\\_p\\_d\\_product\\_top?ie=UTF8](https://www.amazon.com/Klear-Handle-Bottle-Hydro-Flask/dp/B01EXKSRLQ/ref=cm_cr_ar_p_d_product_top?ie=UTF8).\*

Liquid Hardware, Insulated Aqua Silver Sidewinder Vacuum Bottle 20oz./592ml. Powder Coated in USA!, product description, retrieved from internet on Aug. 12, 2015, 3 pages.

Nov. 2, 2016—(WO) International Search Report and Written Opinion—App. No. PCT/US2016/047043—12 pages.

Oct. 18, 2016—(JP) Office Action—App. 2016-010799, English Translation, 3 Pages.

Oct. 18, 2016—(JP) Office Action—App. 2016-010800, English Translation, 3 Pages.

YETI 36 oz. Rambler: Announced Jan. 11, 2016 [online], site visited [May 10, 2016]. Available from Internet URL: <http://yeticoolers.com/rambler-bottle-36-oz/>.

KOLD Vacuum Insulated Stainless Steel Sports Bottle: Announced Dec. 8, 2015 [online], site visited [May 11, 2016]. Available from Internet URL: <http://www.amazon.com/KOLD-Sports-Water-Bottles-Insulated/dp/B018YH K79E/ref=cm>.

“Hydro Flask Insulated Stainless Steel Water Bottle” published on Dec. 29, 2014, retrieved from [http://web.archive.org/web/\\*/https://www.amazon.com/dp/B004X55L9I/ref=twister\\_B00GA03LG4?\\_encoding=UTF8&psc=1](http://web.archive.org/web/*/https://www.amazon.com/dp/B004X55L9I/ref=twister_B00GA03LG4?_encoding=UTF8&psc=1) on Sep. 22, 2016.

“UA Beyond 18 oz. Vacuum Insulated Water Bottle” published on Mar. 29, 2015, retrieved from [http://web.archive.org/web/\\*/https://www.underarmour.com/en-us/beyond-18-oz-vacuum-insulated-ss-bottle-with-flip-top-lid/pid1232014](http://web.archive.org/web/*/https://www.underarmour.com/en-us/beyond-18-oz-vacuum-insulated-ss-bottle-with-flip-top-lid/pid1232014) on Sep. 22, 2016.

“Klean Kanteen Insulated Classic with Polypropylene” published on Jul. 7, 2015, retrieved from [http://web.archive.org/web/\\*/https://www.lifewithoutplastic.com/store/klean-kanteen-insulated-classic-with-polypropylene-loop-cap-0-95-1-32-oz.html](http://web.archive.org/web/*/https://www.lifewithoutplastic.com/store/klean-kanteen-insulated-classic-with-polypropylene-loop-cap-0-95-1-32-oz.html) on Sep. 22, 2016.

“Eco Vessel 64 ounce Growler” published on Jan. 28, 2015, retrieved from [http://web.archive.org/web/\\*/http://www.snewsnet.com/press-release/eco-vessel-launches-the-boss-insulated-growler/](http://web.archive.org/web/*/http://www.snewsnet.com/press-release/eco-vessel-launches-the-boss-insulated-growler/) on Sep. 22, 2016.

“64 oz Double-Wall Vacuum-Insulated Growler” published on Nov. 14, 2014, retrieved from [https://web.archive.org/web/\\*/http://www.fiftyfiftybottles.com/64oz-growler/](https://web.archive.org/web/*/http://www.fiftyfiftybottles.com/64oz-growler/) on Sep. 22, 2016.

“2015 Boulder Insulated Water Bottle with Tea, Fruit, Ice Strainer” published on Jun. 28, 2015, retrieved from [http://web.archive.org/web/\\*/http://www.ecovessel.com/boulder-insulated-water-bottle-with-tea-fruit-ice-strainer-20-oz/](http://web.archive.org/web/*/http://www.ecovessel.com/boulder-insulated-water-bottle-with-tea-fruit-ice-strainer-20-oz/) on Sep. 22.

“KB8 20 oz. Double Wall Stainless Bottle,” published on May 22, 2015, retrieved from <https://web.archive.org/web/20150807054814/http://thermo-steel.com/work/keen-kb8> on Sep. 27, 2016.

Nov. 1, 2016—(JP) Office Action—App. 2016-9606, English Translation, 2 Pages.

Oct. 4, 2016—(JP) Office Action—App 2016-9607, English Translation, 2 pages.

Oct. 4, 2016—(JP) Office Action—App. 2016-9608, English Translation, 2 Pages.

\* cited by examiner

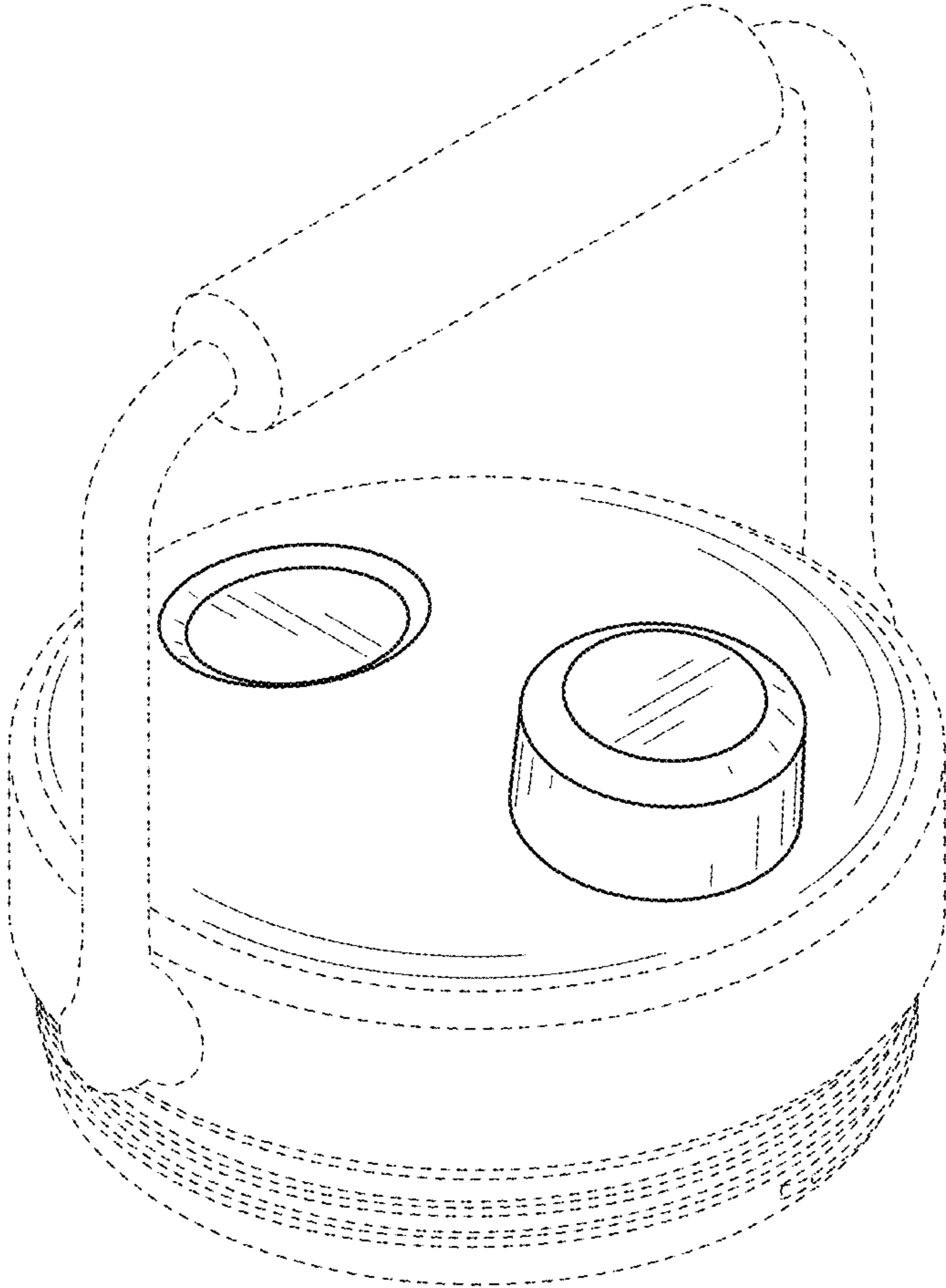

FIG. 1

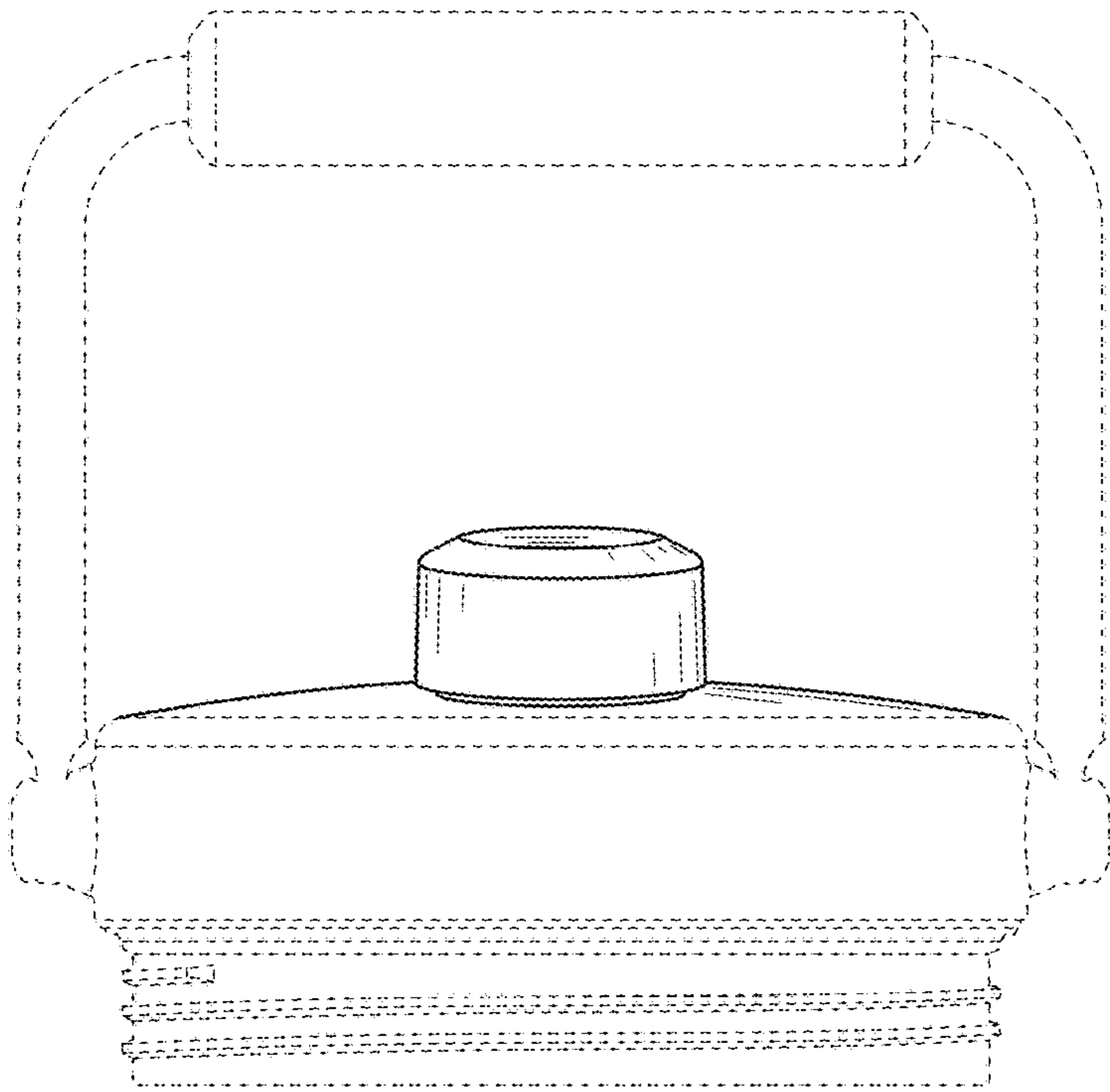

FIG. 2

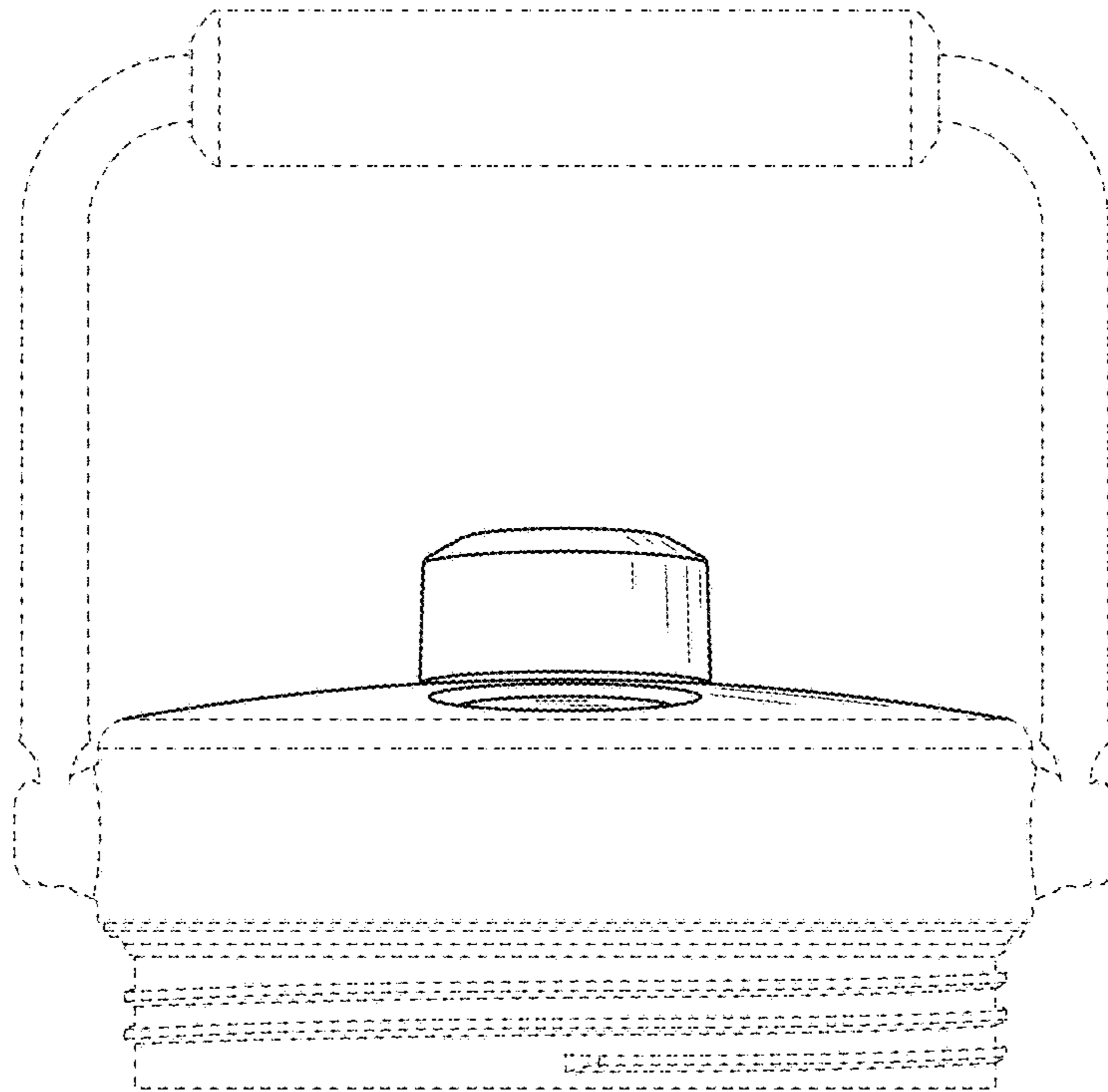

FIG. 3

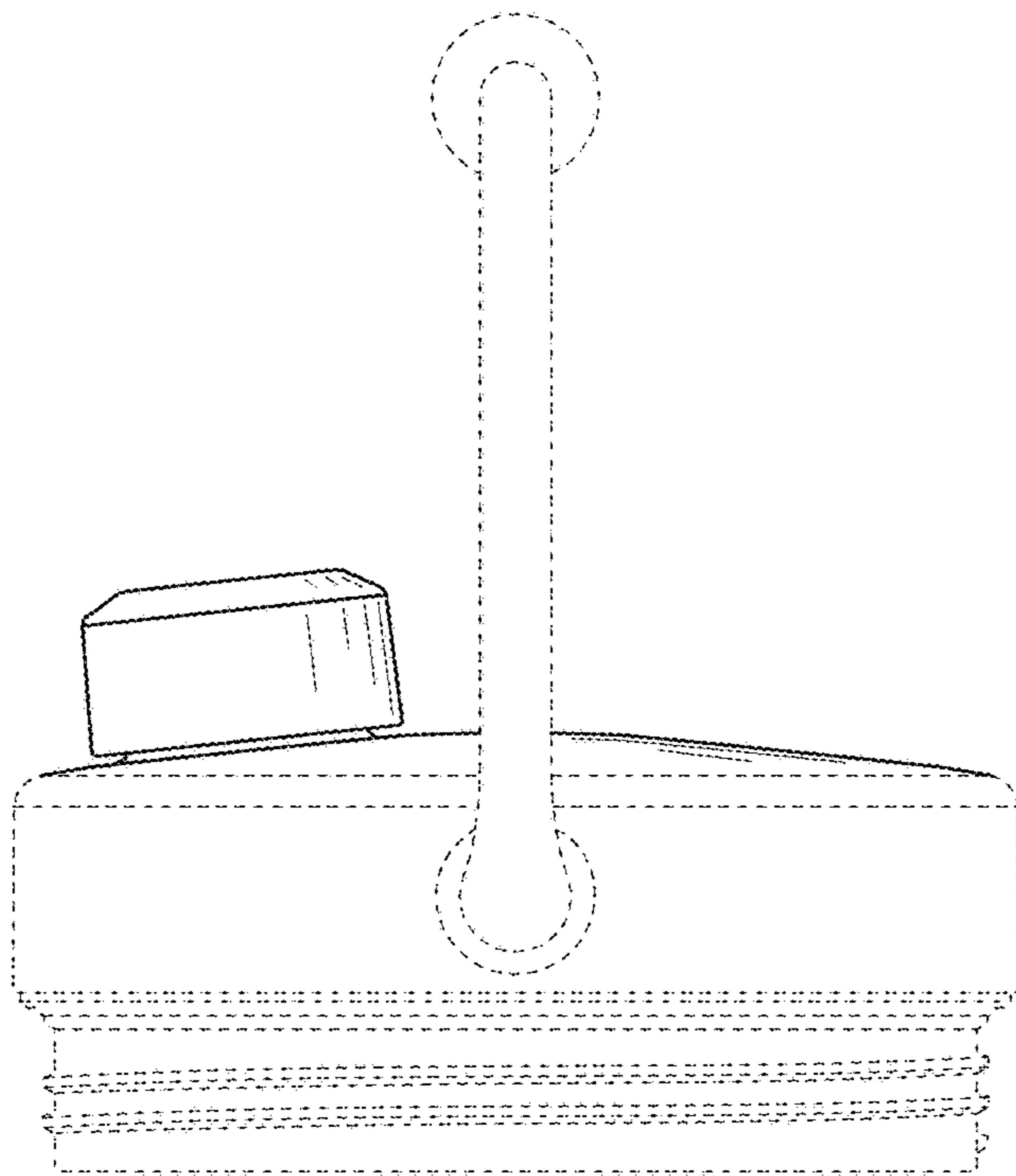

FIG. 4

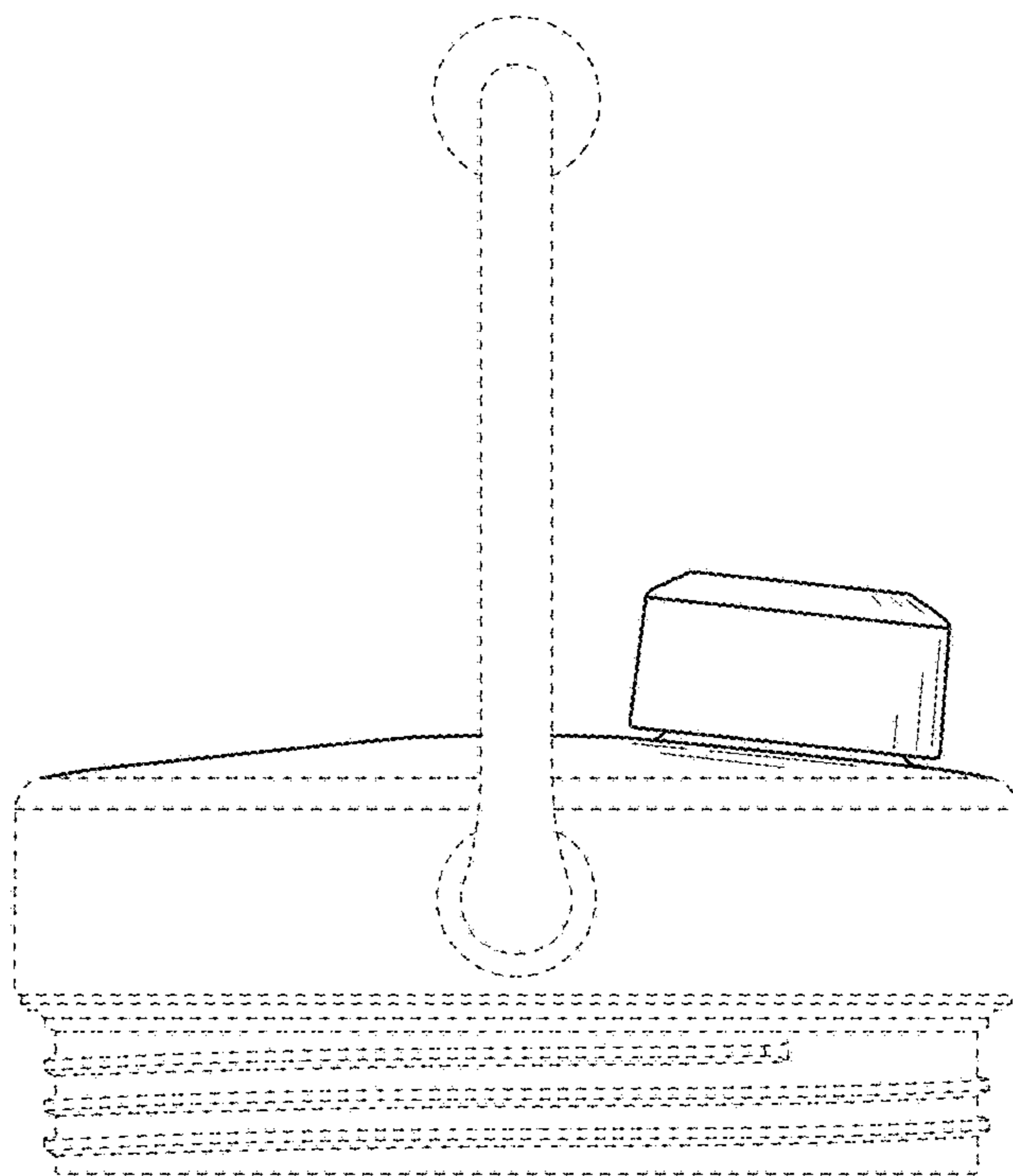

FIG. 5

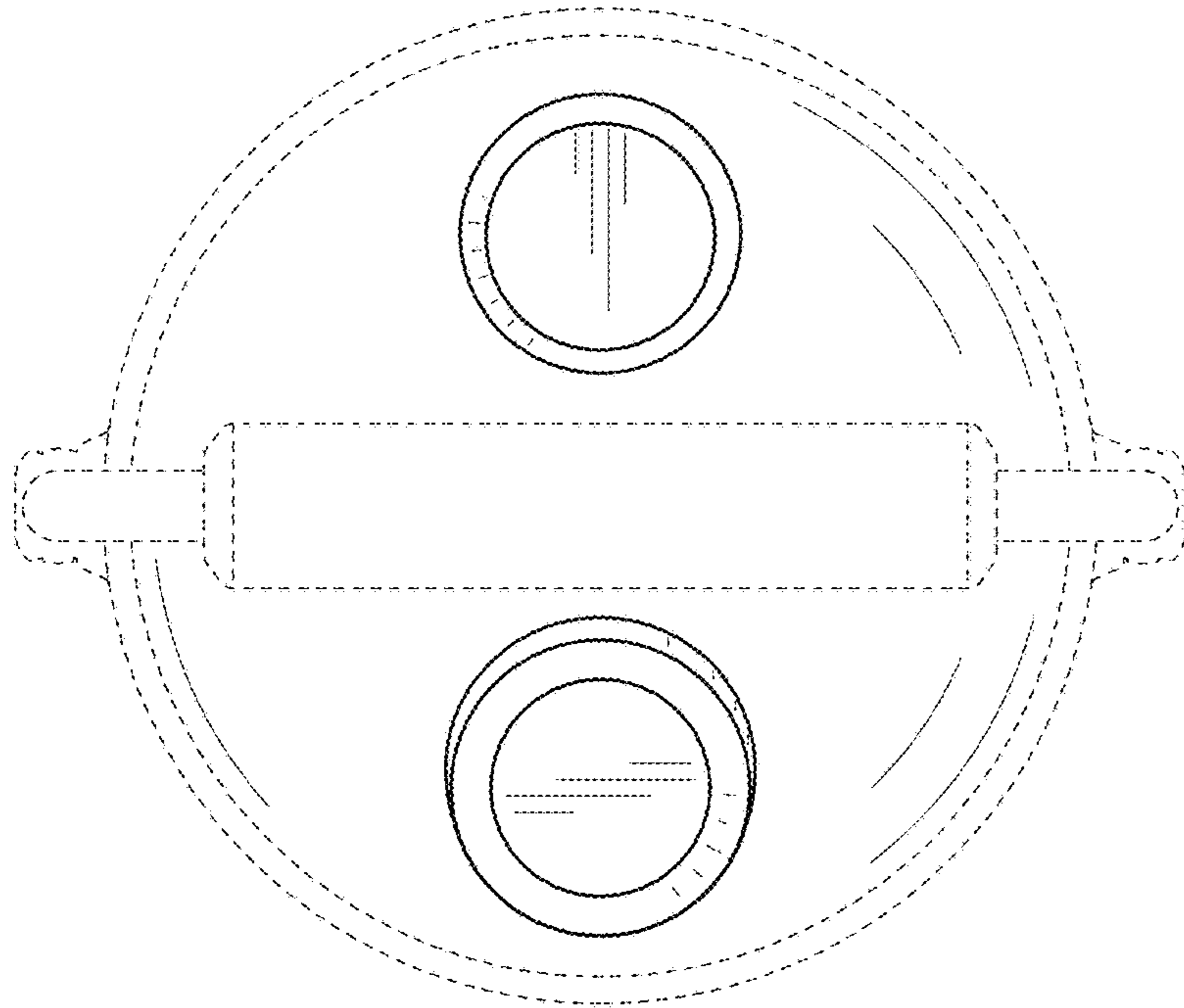

FIG. 6

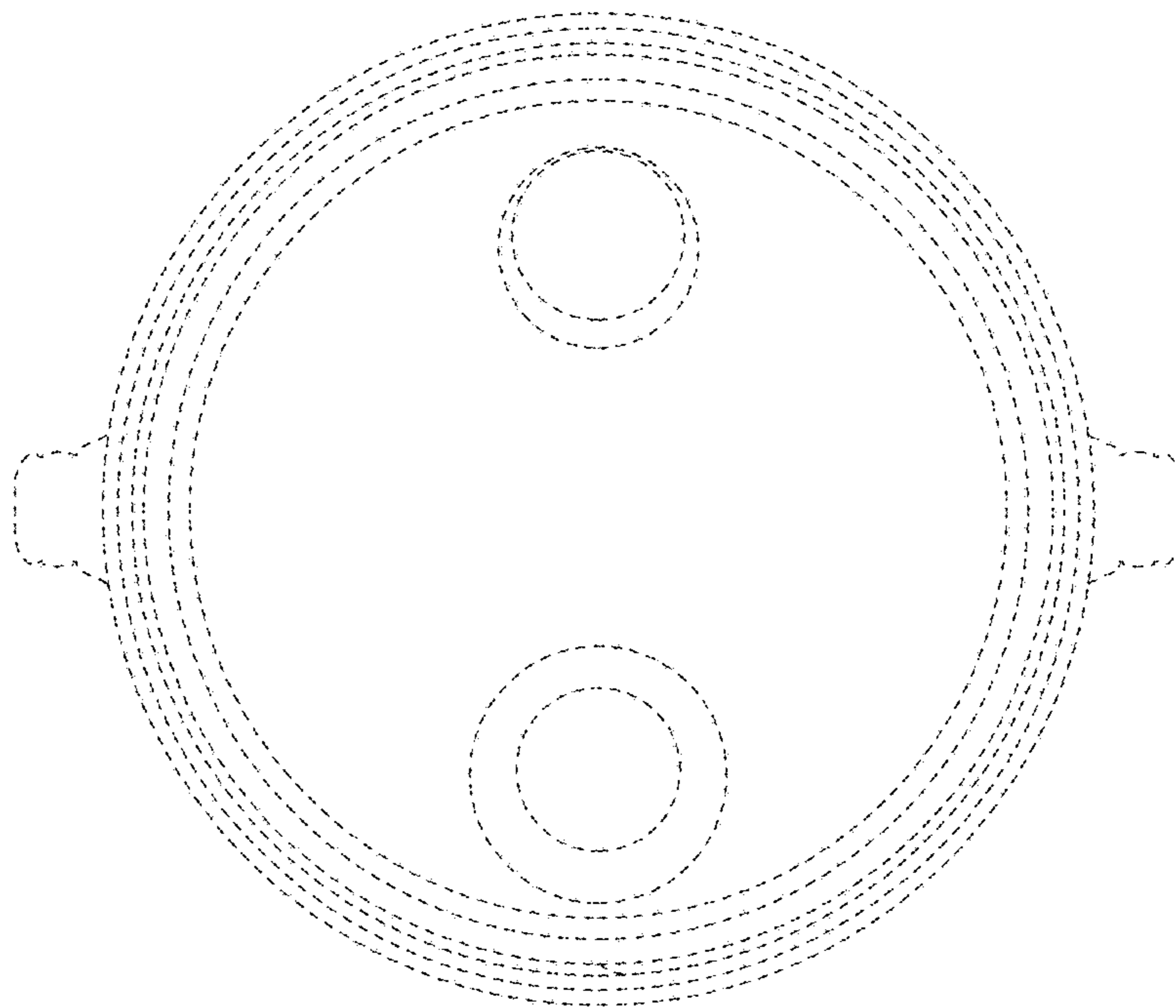

FIG. 7