



US00D802118S

(12) **United States Design Patent** (10) **Patent No.:** **US D802,118 S**
Peret et al. (45) **Date of Patent:** **** Nov. 7, 2017**

(54) **APPARATUS TO CONTROL FLUID FLOW THROUGH A TUBE**

FOREIGN PATENT DOCUMENTS

(71) Applicant: **DEKA Products Limited Partnership**,
Manchester, NH (US)

AU 2247783 A 6/1985
CA 1213749 A1 11/1986
(Continued)

(72) Inventors: **Bob D. Peret**, Bedford, NH (US);
Brian H. Yoo, Cambridge, MA (US);
Kaitlyn S. Clarke, Manchester, NH
(US); **Thomas A. Friedrich**, Loudon,
NH (US); **Derek G. Kane**, Manchester,
NH (US)

OTHER PUBLICATIONS

“The OpenCV Reference Manual Release 2.3”, May 10, 2011, pp.
1-263.

(Continued)

(73) Assignee: **DEKA Products Limited Partnership**,
Manchester, NH (US)

Primary Examiner — Wan Laymon
Assistant Examiner — Mark Booker

(74) *Attorney, Agent, or Firm* — James D. Wyninegar, Jr.

(**) Term: **15 Years**

(57) **CLAIM**

(21) Appl. No.: **29/552,942**

The ornamental design for an apparatus to control fluid flow
through a tube, as shown and described.

(22) Filed: **Jan. 27, 2016**

DESCRIPTION

Related U.S. Application Data

(63) Continuation of application No. 29/471,856, filed on
Nov. 6, 2013, now Pat. No. Des. 751,689.

(51) **LOC (10) Cl.** **24-02**

(52) **U.S. Cl.**
USPC **D24/111**

(58) **Field of Classification Search**
USPC D24/111, 107, 112, 169; D9/526, 529,
D9/668; 604/218, 246, 256, 253,
(Continued)

FIG. 1 is a front, bottom, and right side perspective view of
the apparatus to control fluid flow through a tube, showing
my new design;
FIG. 2 is a front, top, and left side perspective view thereof;
FIG. 3 is a bottom plan view thereof;
FIG. 4 is a top plan view thereof;
FIG. 5 is a left side elevational view thereof;
FIG. 6 is a right side elevational view thereof;
FIG. 7 is a front side elevational view thereof; and,
FIG. 8 is a back side elevational view thereof.

The broken lines shown in the figures represent portions of
the apparatus to control fluid flow through a tube that form
no part of the claimed design.

A broken line shown is a boundary line between the top
portion and the body of the apparatus.

(56) **References Cited**

U.S. PATENT DOCUMENTS

2,880,764 A 4/1959 Pelavin
2,888,877 A 6/1959 Shellman
(Continued)

1 Claim, 8 Drawing Sheets

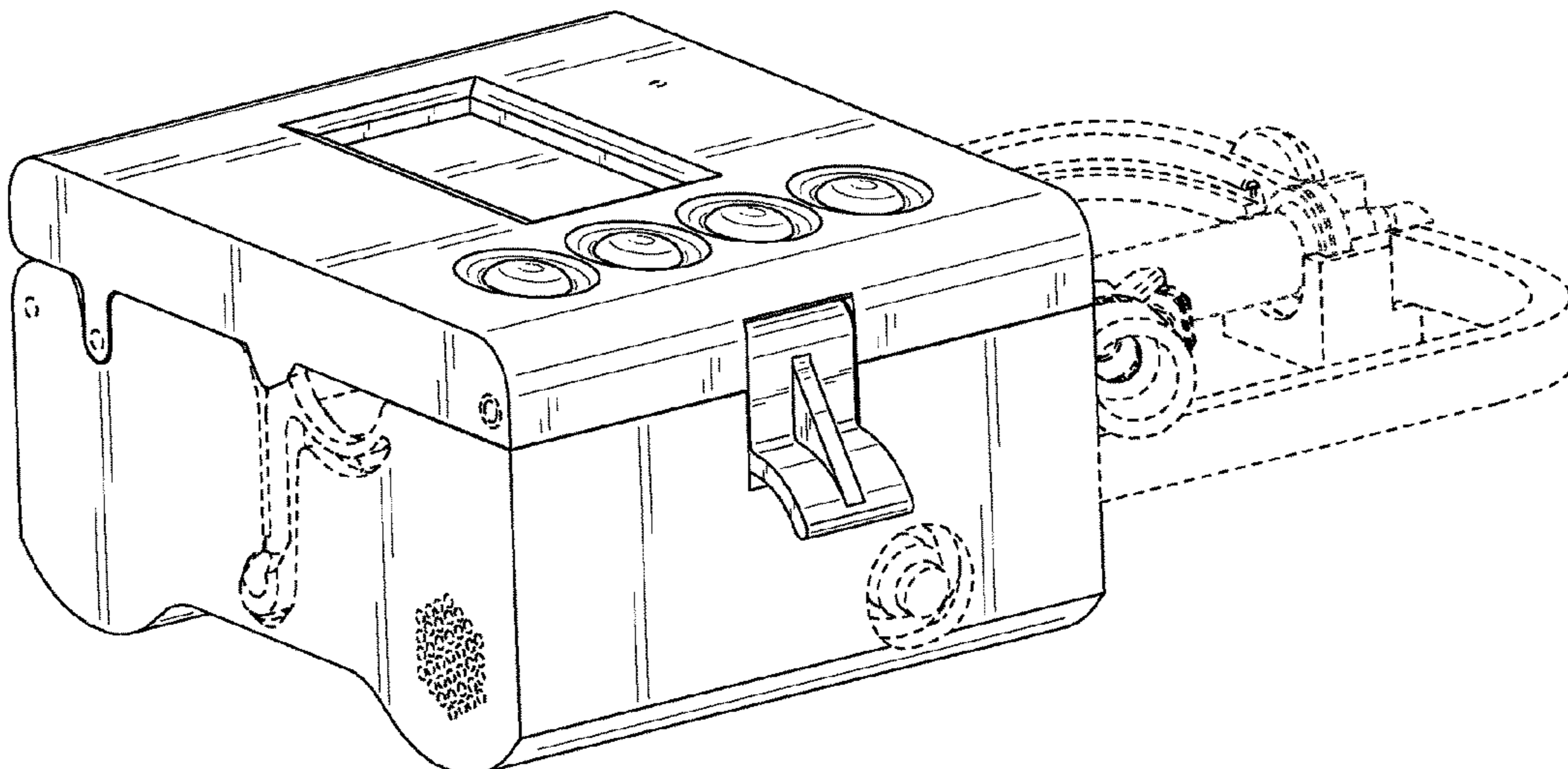

(58) **Field of Classification Search**
 USPC 604/250-251, 108, 169; 417/234;
 206/363-368
 CPC A61M 5/14232; A61M 5/16831; A61M
 5/172; A61M 5/14228; A61M 2205/3365;
 A61M 2205/3313; A61M 5/145; A61M
 5/1689; A61M 5/1413; A61M 5/1415;
 A61M 2205/3569; G01D 5/2451; G01D
 5/3473; Y10S 128/13
 See application file for complete search history.

(56) **References Cited**
 U.S. PATENT DOCUMENTS

3,173,372 A	3/1965	Baldwin	5,267,980 A	12/1993	Dirr, Jr.
3,384,336 A	5/1968	Prockter	5,278,626 A	1/1994	Poole
3,609,379 A	9/1971	Hildebrandt	5,279,558 A	1/1994	Kriesel
3,685,787 A	8/1972	Adelberg	5,314,316 A	5/1994	Shibamoto
3,733,149 A	5/1973	Jacobson	5,328,341 A	7/1994	Forni
3,790,042 A	2/1974	McCormick	5,331,309 A	7/1994	Sakai
3,831,600 A	8/1974	Buckles	5,411,052 A	5/1995	Murray
4,038,982 A	8/1977	Burke	5,415,641 A	5/1995	Yerlikaya
4,105,028 A	8/1978	Sadlier	5,439,442 A	8/1995	Bellifemine
4,155,362 A	5/1979	Jess	D362,721 S	9/1995	Peeler et al.
4,247,077 A	1/1981	Banick et al.	5,482,446 A	1/1996	Williamson
4,303,376 A	12/1981	Siekmann	5,526,285 A	6/1996	Campo
4,321,461 A	3/1982	Walter	5,562,615 A	10/1996	Nassif
4,328,800 A	5/1982	Marx	5,588,963 A	12/1996	Roelofs
4,328,801 A	5/1982	Marx	5,601,980 A	2/1997	Gordon
4,383,252 A	5/1983	Purcell	5,707,588 A	1/1998	Tsukishima
4,397,642 A	8/1983	Lamadrid	5,718,562 A	2/1998	Lawless
4,421,506 A	12/1983	Danby	5,753,820 A	5/1998	Reed
4,449,534 A	5/1984	Saul	5,782,805 A	7/1998	Meinzer
4,469,480 A	9/1984	Figler	5,800,140 A	9/1998	Forni
4,490,140 A	12/1984	Carr	5,800,386 A	9/1998	Bellifemine
4,496,351 A	1/1985	Hillel et al.	5,843,045 A	12/1998	DuPont
4,504,263 A	3/1985	Steuer	5,896,195 A	4/1999	Juvinall
4,525,163 A	6/1985	Slavik	5,899,665 A	5/1999	Makino
4,577,197 A	3/1986	Crean	5,920,361 A	7/1999	Gibeau
4,583,975 A	4/1986	Pekkarinen	D416,999 S	11/1999	Miyamoto
RE32,294 E	11/1986	Knute	6,015,083 A	1/2000	Hayes
4,634,426 A	1/1987	Kamen	6,049,381 A	4/2000	Reintjes
4,635,281 A	1/1987	Jones	6,050,713 A	4/2000	O'Donnell
4,648,869 A	3/1987	Bobo, Jr.	6,083,206 A	7/2000	Molko
4,662,829 A	5/1987	Nehring	6,091,483 A	7/2000	Guirguis
4,668,216 A	5/1987	Martin	6,091,492 A	7/2000	Strickland
4,673,161 A	6/1987	Flynn et al.	6,110,153 A	8/2000	Davis
4,673,820 A	6/1987	Kamen	6,144,453 A	11/2000	Hallerman
4,680,977 A	7/1987	Conero	6,149,631 A	11/2000	Haydel, Jr.
4,703,314 A	10/1987	Spani	6,159,186 A	12/2000	Wickham
4,718,896 A	1/1988	Arndt	6,213,354 B1	4/2001	Kay
4,720,636 A	1/1988	Benner, Jr.	6,213,739 B1	4/2001	Phallen et al.
4,722,224 A	2/1988	Scheller et al.	6,228,047 B1	5/2001	Dadson
4,775,368 A	10/1988	Iwatschenki	D446,860 S	8/2001	Mezière
4,812,904 A	3/1989	Maring	6,305,908 B1	10/2001	Hermann
4,820,268 A	4/1989	Kawamura	6,328,712 B1	12/2001	Cartledge
4,820,281 A	4/1989	Lawler	6,362,887 B1	3/2002	Meisberger
4,834,744 A	5/1989	Ritson	6,491,659 B1	12/2002	Miyamoto
4,837,708 A	6/1989	Wright	6,500,151 B1	12/2002	Cobb
4,846,792 A	7/1989	Bobo, Jr.	6,503,221 B1	1/2003	Briggs
4,909,786 A	3/1990	Gijsselhart	6,523,414 B1	2/2003	Malmstrom
4,920,336 A	4/1990	Meijer	D471,274 S	3/2003	Diaz et al.
4,936,828 A	6/1990	Chiang	6,554,791 B1	4/2003	Cartledge et al.
4,959,050 A	9/1990	Bobo, Jr.	6,562,012 B1	5/2003	Brown
4,979,940 A	12/1990	Bobo, Jr.	6,574,050 B1	6/2003	Lin et al.
4,981,467 A	1/1991	Bobo	6,599,282 B2	7/2003	Burko
5,002,539 A	3/1991	Coble	6,641,556 B1	11/2003	Shigezawa
5,045,069 A	9/1991	Imparato	6,657,545 B1	12/2003	Lin
5,047,014 A *	9/1991	Mosebach A61M 5/142 128/DIG. 13	6,736,801 B1	5/2004	Gallagher
5,057,090 A	10/1991	Bessman	6,810,290 B2	10/2004	Lebel et al.
5,154,693 A	10/1992	East et al.	6,814,547 B2	11/2004	Childers et al.
5,154,704 A	10/1992	Archibald	6,975,898 B2	12/2005	Seibel
5,181,910 A	1/1993	Scanlon	6,984,052 B1	1/2006	Del Castillo
5,186,057 A	2/1993	Everhart	7,001,365 B2	2/2006	Makkink
RE34,413 E	10/1993	McCullough	7,068,831 B2	6/2006	Florent
			7,070,121 B2	7/2006	Schramm
			7,118,549 B2	10/2006	Chan
			7,163,740 B2	1/2007	Rosati
			7,190,275 B2	3/2007	Goldberg
			D564,087 S	3/2008	Yodfat et al.
			7,338,475 B2	3/2008	Brown
			7,420,151 B2	9/2008	Fengler et al.
			7,448,706 B2	11/2008	Yamanobe
			7,467,055 B2	12/2008	Seshimo
			7,498,563 B2	3/2009	Mandro
			7,499,581 B2	3/2009	Tribble
			7,540,859 B2	6/2009	Claude
			7,677,689 B2	3/2010	Kim
			7,695,448 B2	4/2010	Cassidy
			7,767,991 B2	8/2010	Sacchetti
			7,776,927 B2	8/2010	Chu
			7,783,107 B2	8/2010	Zandifar
			D629,503 S	12/2010	Caffey et al.

US D802,118 S

(56)	<p style="text-align: center;">References Cited</p> <p style="text-align: center;">U.S. PATENT DOCUMENTS</p>			
	7,892,201 B1	2/2011	Laguna	2006/0291211 A1 12/2006 Rodriguez
	7,892,204 B2	2/2011	Kraus	2007/0088269 A1* 4/2007 Valego A61M 5/142 604/151
	7,905,859 B2	3/2011	Bynum	2007/0102623 A1 5/2007 Fengler
	7,914,483 B2	3/2011	Simmons	2007/0228071 A1 10/2007 Kamen et al.
	7,918,834 B2	4/2011	Mernoe	2007/0293817 A1 12/2007 Feng
	7,924,424 B2	4/2011	Erickson et al.	2008/0004574 A1 1/2008 Dyar
	7,933,780 B2	4/2011	De La Huerga	2008/0051732 A1 2/2008 Chen
	7,952,698 B2	5/2011	Friedrich	2008/0147008 A1 6/2008 Lewis
	8,004,683 B2	8/2011	Tokhtuev et al.	2008/0147016 A1 6/2008 Faries
	8,025,634 B1	9/2011	Moubayed	2008/0154214 A1 6/2008 Spohn
	8,038,657 B2	10/2011	Davis	2008/0235765 A1 9/2008 Shimizu
	8,038,663 B2	10/2011	Miner	2008/0237502 A1 10/2008 Fago
	8,103,461 B2	1/2012	Glaser et al.	2008/0252472 A1 10/2008 Su et al.
	8,112,814 B2	2/2012	Shimizu	2009/0097029 A1 4/2009 Tokhtuev
	8,137,083 B2	3/2012	Zhou	2009/0112115 A1 4/2009 Huang
	8,147,447 B2	4/2012	Sundar et al.	2009/0180106 A1 7/2009 Friedrich
	8,147,448 B2	4/2012	Sundar	2009/0224638 A1 9/2009 Weber
	8,147,464 B2	4/2012	Spohn	2009/0254025 A1 10/2009 Simmons
	8,184,848 B2	5/2012	Wu	2009/0262351 A1 10/2009 Erickson
	8,256,984 B2	9/2012	Fathallah	2009/0276167 A1 11/2009 Glaser
	8,257,779 B2	9/2012	Abernathy	2009/0281460 A1 11/2009 Lowery
	8,282,894 B2	10/2012	Lee	2010/0021933 A1 1/2010 Okano
	D676,551 S	2/2013	Desai et al.	2010/0097451 A1 4/2010 Bruce
	D677,784 S *	3/2013	Marguerie D24/111	2010/0114027 A1 5/2010 Jacobson
	8,394,062 B2	3/2013	Powers	2010/0120601 A1 5/2010 Hayamizu
	8,439,880 B2	5/2013	Rondeau	2010/0168671 A1 7/2010 Faries, Jr.
	8,447,069 B2	5/2013	Huang et al.	2010/0204650 A1 8/2010 Hungerford et al.
	8,471,231 B2	6/2013	Paz	2010/0211003 A1 8/2010 Sundar
	8,523,797 B2	9/2013	Lowery et al.	2010/0217229 A1 8/2010 Miner
	8,523,829 B2	9/2013	Miner et al.	2010/0229978 A1 9/2010 Zhou
	8,523,839 B2	9/2013	Siefert	2010/0292635 A1 11/2010 Sundar
	8,529,511 B2	9/2013	Boulanger	2010/0309005 A1 12/2010 Warner
	8,531,517 B2	9/2013	Tao	2011/0004186 A1 1/2011 Butterfield
	8,552,361 B2	10/2013	Mandro	2011/0025826 A1 2/2011 Dabiri
	8,622,979 B2	1/2014	Hungerford	2011/0046899 A1 2/2011 Paz
	8,638,358 B2	1/2014	Dabiri et al.	2011/0060284 A1* 3/2011 Harr A61M 5/14244 604/153
	8,647,074 B2	2/2014	Moberg et al.	2011/0125103 A1 5/2011 Rondeau
	8,692,678 B2	4/2014	Warner et al.	2011/0142283 A1 6/2011 Huang
	8,777,897 B2	7/2014	Butterfield	2011/0144595 A1 6/2011 Cheng
	D712,043 S	8/2014	Sliger	2011/0166511 A1 7/2011 Sharvit
	8,834,429 B2	9/2014	Grant	2011/0178476 A1 7/2011 Lin
	D720,449 S	12/2014	Galbraith et al.	2011/0190146 A1 8/2011 Boehm
	D728,779 S	5/2015	Sabin et al.	2011/0190637 A1 8/2011 Knobel
	D735,319 S	7/2015	Sabin et al.	2011/0196304 A1 8/2011 Kramer et al.
	D736,370 S	8/2015	Sabin et al.	2011/0196306 A1 8/2011 De La Huerga
	9,095,652 B2	8/2015	Dewey	2011/0206247 A1 8/2011 Dachille
	9,128,051 B2	9/2015	Bui	2011/0208123 A1 8/2011 Gray
	9,134,735 B2	9/2015	Lowery et al.	2011/0231204 A1 9/2011 De La Huerga
	9,134,736 B2	9/2015	Lowery et al.	2011/0251557 A1 10/2011 Powers
	9,144,644 B2	9/2015	Hungerford	2011/0275063 A1 11/2011 Weitz
	9,151,646 B2	10/2015	Kamen et al.	2011/0313351 A1 12/2011 Kamen
	D745,661 S	12/2015	Collins et al.	2011/0313789 A1 12/2011 Kamen
	9,216,279 B2	12/2015	Travis et al.	2011/0316919 A1 12/2011 Baldy, Jr.
	9,234,850 B2	1/2016	Hammond et al.	2011/0317004 A1 12/2011 Tao
	D749,206 S	2/2016	Johnson et al.	2012/0013735 A1 1/2012 Tao
	D751,689 S	3/2016	Peret et al.	2012/0059318 A1 3/2012 Dewey
	D751,690 S	3/2016	Peret et al.	2012/0059350 A1 3/2012 Siefert
	D752,209 S	3/2016	Peret et al.	2012/0095415 A1 4/2012 Sharvit
	9,295,778 B2	3/2016	Kamen et al.	2012/0095433 A1 4/2012 Hungerford
	D754,065 S	4/2016	Gray et al.	2012/0185267 A1 7/2012 Kamen
	D760,888 S *	7/2016	Gill D24/108	2012/0197185 A1 8/2012 Tao
	2001/0026292 A1	10/2001	Ishizaki	2012/0238997 A1 9/2012 Dewey
	2001/0055462 A1	12/2001	Seibel	2012/0265166 A1 10/2012 Yodfat
	2002/0194933 A1	12/2002	Roelofs	2012/0310153 A1 12/2012 Moberg
	2003/0045840 A1	3/2003	Burko	2012/0310205 A1* 12/2012 Lee G06F 19/3418 604/500
	2003/0055406 A1	3/2003	Lebel	2013/0035659 A1 2/2013 Hungerford
	2003/0107819 A1	6/2003	Lin et al.	2013/0083191 A1 4/2013 Lowery et al.
	2003/0217962 A1	11/2003	Childers	2013/0085443 A1 4/2013 Lowery
	2004/0044306 A1	3/2004	Lynch et al.	2013/0177455 A1 7/2013 Kamen
	2004/0171994 A1	9/2004	Goldberg	2013/0182381 A1 7/2013 Gray
	2005/0096581 A1	5/2005	Chan	2013/0184676 A1 7/2013 Kamen
	2005/0171491 A1	8/2005	Minh Miner et al.	2013/0188040 A1 7/2013 Kamen
	2006/0096660 A1	5/2006	Diaz	2013/0191513 A1 7/2013 Kamen
	2006/0140466 A1	6/2006	Seshimo	2013/0197693 A1 8/2013 Kamen
	2006/0146077 A1	7/2006	Song	2013/0201471 A1 8/2013 Bui et al.
				2013/0201482 A1 8/2013 Munro

(56)

References Cited

U.S. PATENT DOCUMENTS

2013/0204188 A1* 8/2013 Kamen G06F 19/3418
604/152

2013/0253442 A1 9/2013 Travis

2013/0272773 A1 10/2013 Kamen

2013/0281965 A1 10/2013 Kamen

2013/0297330 A1 11/2013 Kamen

2013/0310990 A1 11/2013 Peret et al.

2013/0317753 A1 11/2013 Kamen

2013/0317837 A1 11/2013 Ballantyne

2013/0336814 A1 12/2013 Kamen

2013/0339049 A1 12/2013 Blumberg, Jr.

2013/0346108 A1 12/2013 Kamen

2014/0043469 A1 2/2014 Engel

2014/0081233 A1 3/2014 Hungerford

2014/0135695 A1 5/2014 Grant

2014/0148757 A1 5/2014 Ambrosina

2014/0165703 A1 6/2014 Wilt

2014/0180711 A1 6/2014 Kamen

2014/0188076 A1 7/2014 Kamen

2014/0188516 A1 7/2014 Kamen

2014/0194818 A1 7/2014 Yodfat

2014/0195639 A1 7/2014 Kamen

2014/0227021 A1 8/2014 Kamen

2014/0267709 A1 9/2014 Hammond

2014/0276457 A1 9/2014 Munro

2014/0309612 A1 10/2014 Smisson, III

2014/0318639 A1 10/2014 Peret

2014/0327759 A1 11/2014 Tao

2014/0340512 A1 11/2014 Tao

2014/0343492 A1 11/2014 Kamen

2015/0002667 A1 1/2015 Peret et al.

2015/0002668 A1 1/2015 Peret et al.

2015/0002677 A1 1/2015 Peret

2015/0023808 A1* 1/2015 Zhu F04B 39/00
417/63

2015/0033823 A1 2/2015 Blumberg, Jr.

2015/0154364 A1 6/2015 Biasi et al.

2015/0157791 A1 6/2015 Desch et al.

2015/0219881 A1 8/2015 Munro

2015/0257974 A1 9/2015 Demers et al.

2015/0314083 A1 11/2015 Blumberg, Jr. et al.

2015/0332009 A1 11/2015 Kane et al.

2015/0361974 A1 12/2015 Hungerford et al.

2016/0025641 A1 1/2016 Hammond et al.

2016/0055397 A1 2/2016 Peret et al.

2016/0055649 A1 2/2016 Peret et al.

2016/0061641 A1 3/2016 Peret et al.

2016/0063353 A1 3/2016 Peret et al.

2016/0073063 A1 3/2016 Peret et al.

2016/0084434 A1 3/2016 Janway et al.

2016/0097382 A1 4/2016 Kamen et al.

2016/0287780 A1* 10/2016 Lee A61M 5/142

FOREIGN PATENT DOCUMENTS

DE 2023027 A1 11/1970

DE 2631951 A1 1/1978

DE 3617723 A1 12/1987

DE 3643276 A1 6/1988

DE 3822057 C2 1/1989

DE 69229832 T2 2/2000

EP 0112699 A2 7/1984

EP 0441323 A1 8/1991

EP 1722310 A1 11/2006

EP 2319551 A2 5/2011

EP 2793977 B1 11/2015

FR 2042606 A1 2/1971

FR 2273264 A1 12/1975

FR 2458804 1/1981

FR 2617593 1/1989

GB 1301033 A 12/1972

GB 2020735 A 11/1979

GB 2207239 B 1/1989

GB 2328982 A 3/1999

JP 58163843 9/1983

JP 04-280582 A 10/1992

JP 3110458 B2 11/2000

JP 2007229928 A 9/2007

JP 2009298012 A 12/2009

JP 2011062371 A 3/2011

KR 1020100037914 A 4/2010

NL 7006908 11/1970

NL 8801680 A 2/1989

NL 9101825 A 5/1993

SE 376843 B 6/1975

WO WO8102770 A1 10/1981

WO WO9309407 A1 5/1993

WO WO0072181 A3 11/2000

WO WO0240084 A2 5/2002

WO WO02010262 A1 12/2002

WO WO2004035116 A1 4/2004

WO WO2005094919 A1 10/2005

WO WO2006086723 A2 8/2006

WO WO2008022880 A1 2/2008

WO WO2008079023 A1 7/2008

WO WO2009039203 A2 3/2009

WO WO2009039214 A2 3/2009

WO WO2009055639 A2 4/2009

WO WO2010020397 A1 4/2010

WO WO2010129720 A2 11/2010

WO WO2011021098 A1 2/2011

WO WO2011136667 A1 11/2011

WO WO2013095459 A1 12/2011

WO WO2012104779 A1 8/2012

WO WO2013096713 A1 12/2012

WO WO2013096718 A1 12/2012

WO WO2013096722 A1 12/2012

WO WO2013096909 A1 12/2012

WO WO2013017949 A2 2/2013

WO WO2013176770 A1 3/2013

WO WO/2013/177357 A1 5/2013

WO WO2013070337 A1 5/2013

WO WO2013095459 A9 6/2013

WO WO2013096713 A2 6/2013

WO WO2013096718 A2 6/2013

WO WO2013096722 A2 6/2013

WO WO2013096909 A2 6/2013

WO WO2013176770 A2 11/2013

WO WO2013177357 A1 11/2013

WO WO/2014/100571 A1 12/2013

WO WO/2014/100658 A1 12/2013

WO WO/2014/100687 A1 12/2013

WO WO/2014/100744 A1 12/2013

WO WO2014100557 A1 12/2013

WO WO2014100736 A1 12/2013

WO WO/2014/144557 A1 3/2014

WO WO2014100557 A2 6/2014

WO WO2014100571 A2 6/2014

WO WO2014100658 A1 6/2014

WO WO2014100687 A2 6/2014

WO WO2014100736 A2 6/2014

WO WO2014100744 A2 6/2014

WO WO2015017275 A1 7/2014

WO WO2014144557 A2 9/2014

WO WO2014025736 A1 10/2014

WO WO2014160058 A2 10/2014

WO WO2014160249 A1 10/2014

WO WO2014160307 A1 10/2014

WO WO2015017275 A1 2/2015

WO WO2015116557 A1 8/2015

OTHER PUBLICATIONS

Invitation to Respond to Written Opinion from the Intellectual Property Office of Singapore for Application 11201507504S, mailed on Nov. 23, 2015.

First Examination Report from The Intellectual Property Office of New Zealand for Application 626382, mailed on Apr. 1, 2015.

Report of substantive examination from Superintendent of Industry and Commerce of Colombia for Patent Application 14155193, mailed on Nov. 19, 2015.

(56)

References Cited

OTHER PUBLICATIONS

Notice of Preliminary Rejection (Non-Final) from the Korean Intellectual Property Office (“KIPO”) for Korean Patent Application No. 10-2014-7019883, mailed on Dec. 15, 2015.

First Examination report from the New Zealand Intellectual Property Office for New Zealand IP No. 715098, mailed on Jan. 12, 2016.

“Microcomputer Intravenous Infusion Drip Controller”, Longfian Scitech Co., Ltd., Mar. 18, 2016 (retrieved). Advertisement listed as having a valid price starting at Mar. 10, 2016, 2 pgs, <http://marina.en.made-in-china.com/productimage/bKvQTtJcJEhs-2flj00FZetfTsdnhcU/China-Microcomputer-Intravenous-Infusion-Drip-Controller.html>.

“DripAssist Specificaiton”, Shift Labs , Mar. 18, 2016 (retrieved). 2 pgs, <http://www.shiftlabs.com/products/dripassist/specifications>.

“DripAssist Product Overview”, Shift Labs , Mar. 18, 2016 (retrieved). 2 pgs, <http://www.shiftlabs.com/products/dripassist/overview>.

“DripAssist Product Brochure”, Shift Labs , Mar. 18, 2016 (retrieved). 1 pg., <http://www.shiftlabs.com/sites/default/files/DripAssistOnesheet.pdf>.

“IUV Drip monitor”, Allison Lipper, Mar. 18, 2016 (retrieved). 3 pgs., <http://cnx.org/contents/WmaFki2-@3/IV-Drip-Monitor>.

“AutoClamp”, Ace Medical, Mar. 18, 2016 (retrieved). 2 pgs., http://ace-medical.com/2014/en/product/product/view.asp?po_no=31.

Extended European Search Report dated Mar. 3, 2016, received in European patent application No. 15192051.9, 7 pgs.

AAMI and FDA, Infusing Patients Safely: Priority Issues from the AAMI/FDA Infusion Device Summit, Symposium, Oct. 5-6, 2010, pp. 1-48, AAMI, Arlington, VA, USA.

Conway, “Analytical Analysis of Tip Travel in a Bourdon Tube”, Master’s Thesis, Naval Postgraduate School Monterey, Dec. 1995, pp. i-89.

Darzynkiewicz, ‘Cytometry’, Methods in Cell Biology, 2011, Third Edition Part A, vol. 63, pp. 44-48, Academic Press, San Diego, 2001. And please see whole document generally.

“Feature Detection”, OpenCV Wiki, Oct. 31, 2011 (retrieved), 7 pgs, http://opencv.willowgarage.com/documentation/cpp/imgproc_feature_detection.html.

Galambos et al., “Progressive Probabilistic Hough Transform for Line Detection”, IEEE, 10 pgs, 1999.

International Search Report & Written Opinion dated May 14, 2012, received in International patent application No. PCT/US2011/066588, 9 pgs.

International Search Report & Written Opinion dated Jun. 18, 2013, received in International patent application No. PCT/US2012/071142, 14 pgs.

International Search Report & Written Opinion dated Oct. 1, 2013, received in International patent application No. PCT/US2012/071490, 19 pgs.

International Search Report & Written Opinion dated Dec. 4, 2013, received in International patent application No. PCT/US2013/032445, 20 pgs.

International Search Report & Written Opinion dated Nov. 7, 2013, received in International patent application No. PCT/US2013/042350, 18 pgs.

Invitation to Pay Additional Fees and, Where Applicable, Protest Fee dated Sep. 9, 2013, received in International patent application No. PCT/US2013/032445, 10 pgs.

Invitation to Pay Additional Fees and, Where Applicable, Protest Fee dated Sep. 26, 2013, received in International patent application No. PCT/US2013/042350, 7 pgs.

International Preliminary Report on Patentability dated Jul. 3, 2014, received in International patent application No. PCT/US2012/071142, 9 pgs.

International Search Report dated Feb. 5, 2015, received in International patent application No. PCT/US2014/029020, 7 pgs.

International Preliminary Report on Patentability and Written Opinion, dated Sep. 2015, received in International patent application No. PCT/US2014/029020, 11 pgs.

Hofmann, “Modeling Medical Devices for Plug-and-Play Interoperability”, MIT Department of Electrical Engineering and Computer Science, Jun. 2007, pp. 1-187.

King et al. Prototyping closed loop physiologic control with the medical device coordination framework. In SEHC 2010: Proceedings of the 2010 ICSE Workshop on Software Engineering in Health Care (pp. 1-11). New York, NY: ACM. (2010).

Jetley et al., “Safety Requirements Based Analysis of Infusion Pump Software”, Proceedings of the IEEE Real Time Systems Symposium, Tuscon, Dec. 2007 pp. 1-4.

FDA US Food and Drug Administration, “SEDASYS ® Computer-Assisted Personalized Sedation System P08000”, Jul. 16, 2013, pp. 1-2, www.fda.gov/MedicalDevices/ProductsandMedicalProcedures/DeviceApprovalsandClearances/Recently-ApprovedDevices/ucm353950.htm.

Luerkens, David W. “Theory and Application of Morphological Analysis: Fine Particles and Surfaces”. Boca Raton: CRC, 1991. 5-7.

Matas et al., ‘Progressive Probabilistic Hough Transform’, University of Surrey, Czech Technical University, 1998, pp. 1-10.

“Miscellaneous Image Transformations”, OpenCV Wiki, 2011, 9 pgs., http://opencv.willowgarage.com/documentation/cpp/miscellaneous_image_transformations.

National Patient Safety Agency, Design for Patient Safety: A Guide to the Design of Electronic Infusion Devices, booklet, 2010, pp. 1-96, Edition 1, National Patient Safety Agency, London.

“Object Detection”, OpenCV Wiki, 2011, 2 pgs., http://opencv.willowgarage.com/documentation/cpp/object_detection.html.

“The OpenCV Reference Manual Release 2.4.6.0”, Jul. 1, 2013, pp. 1-813.

Leor et al., “A System for the Measurement of Drop Volume of Intravenous Solutions”, Proceedings Computers in Cardiology 1990, pp. 405-406, Los Alamitos, California.

Butterfield, “Alaris SE Pump, Monitoring and Detection of IV Line Occlusions.”, CareFusion Corporation, 2010, 4 pgs.

“Vista Basic: Instructions for Use: Software IFVB”, manual, 2002, pp. 3, B. Braun Medical Inc.

Hugli et al., “Drop volume measurement by vision.” Proceedings of SPIE Electronic Imaging Conference, San Diego, Jan. 2000. SPIE vol. 3866-11, pp. 60-66.

U.S. Appl. No. 61/297,544, filed Jan. 22, 2010.

U.S. Appl. No. 61/578,674, filed Dec. 21, 2011.

U.S. Appl. No. 61/578,649, filed Dec. 21, 2011.

U.S. Appl. No. 61/578,658, filed Dec. 21, 2011.

U.S. Appl. No. 61/651,322, filed May 24, 2012.

U.S. Appl. No. 61/679,117, filed Aug. 3, 2012.

U.S. Appl. No. 61/738,447, filed Dec. 18, 2012.

U.S. Appl. No. 61/740,474, filed Dec. 21, 2012.

U.S. Appl. No. 29/457,521, filed Jun. 11, 2013.

U.S. Appl. No. 61/843,574, filed Jul. 8, 2013.

U.S. Appl. No. 61/860,398, filed Jul. 31, 2013.

U.S. Appl. No. 61/894,801, filed Oct. 23, 2013.

U.S. Appl. No. 61/900,431, filed Nov. 6, 2013.

U.S. Appl. No. 61/904,123, filed Nov. 14, 2013.

U.S. Appl. No. 29/477,236, filed Dec. 20, 2013.

U.S. Appl. No. 29/477,242, filed Dec. 20, 2013.

U.S. Appl. No. 29/477,233, filed Dec. 20, 2013.

U.S. Appl. No. 29/477,232, filed Dec. 20, 2013.

U.S. Appl. No. 29/477,231, filed Dec. 20, 2013.

U.S. Appl. No. 29/477,237, filed Dec. 20, 2013.

U.S. Appl. No. 29/477,249, filed Dec. 20, 2013.

U.S. Appl. No. 61/942,986, filed Feb. 21, 2014.

U.S. Appl. No. 61/953,036, filed Mar. 14, 2014.

U.S. Appl. No. 61/987,742, filed May 2, 2014.

U.S. Appl. No. 61/990,330, filed May 8, 2014.

U.S. Appl. No. 62/052,008, filed Sep. 18, 2014.

U.S. Appl. No. 62/086,356, filed Dec. 2, 2014.

U.S. Appl. No. 29/517,095, filed Feb. 10, 2015.

U.S. Appl. No. 29/517,097, filed Feb. 10, 2015.

(56)

References Cited

OTHER PUBLICATIONS

U.S. Appl. No. 29/517,099, filed Feb. 10, 2015.
U.S. Appl. No. 29/517,100, filed Feb. 10, 2015.
U.S. Appl. No. 29/517,101, filed Feb. 10, 2015.
U.S. Appl. No. 29/517,096, filed Feb. 10, 2015.
PCT/US15/16796, Feb. 27, 2015.
U.S. Appl. No. 62/168,343, filed May 29, 2015.
U.S. Appl. No. 29/531,366, filed Jun. 25, 2015.
U.S. Appl. No. 29/532,660, filed Jul. 9, 2015.
U.S. Appl. No. 29/538,153, filed Sep. 1, 2015.
U.S. Appl. No. 62/212,871, filed Sep. 1, 2015.
U.S. Appl. No. 14/853,300, filed Sep. 14, 2015.
PCT/US15/49952, Sep. 14, 2015.
U.S. Appl. No. 14/939,586, filed Nov. 12, 2015.
PCT/US2015/63359, Dec. 2, 2015.
U.S. Appl. No. 29/547,402, filed Dec. 3, 2015.
U.S. Appl. No. 29/547,405, filed Dec. 3, 2015.

U.S. Appl. No. 29/548,225, filed Dec. 11, 2015.
U.S. Appl. No. 29/552,303, filed Jan. 21, 2016.
U.S. Appl. No. 29/552,943, filed Jan. 27, 2016.
U.S. Appl. No. 62/288,132, filed Jan. 28, 2016.
U.S. Appl. No. 29/553,094, filed Jan. 28, 2016.
U.S. Appl. No. 29/556,048, filed Feb. 26, 2016.
U.S. Appl. No. 15/055,941, filed Feb. 29, 2016.
U.S. Appl. No. 15/059,394, filed Mar. 3, 2016.
U.S. Appl. No. 15/077,389, filed Mar. 22, 2016.
U.S. Appl. No. 29/561,572, filed Apr. 18, 2016.

Report of substantive examination from Superintendent of Industry and Commerce of Colombia for Patent Application 14155193, mailed on Nov. 19, 2015, English Machine Translation.

Notice of Preliminary Rejection (Non-Final) from the Korean Intellectual Property Office (“KIPO”) for Korean Patent Application No. 10-2014-7019883, mailed on Dec. 15, 2015, English Translation.

* cited by examiner

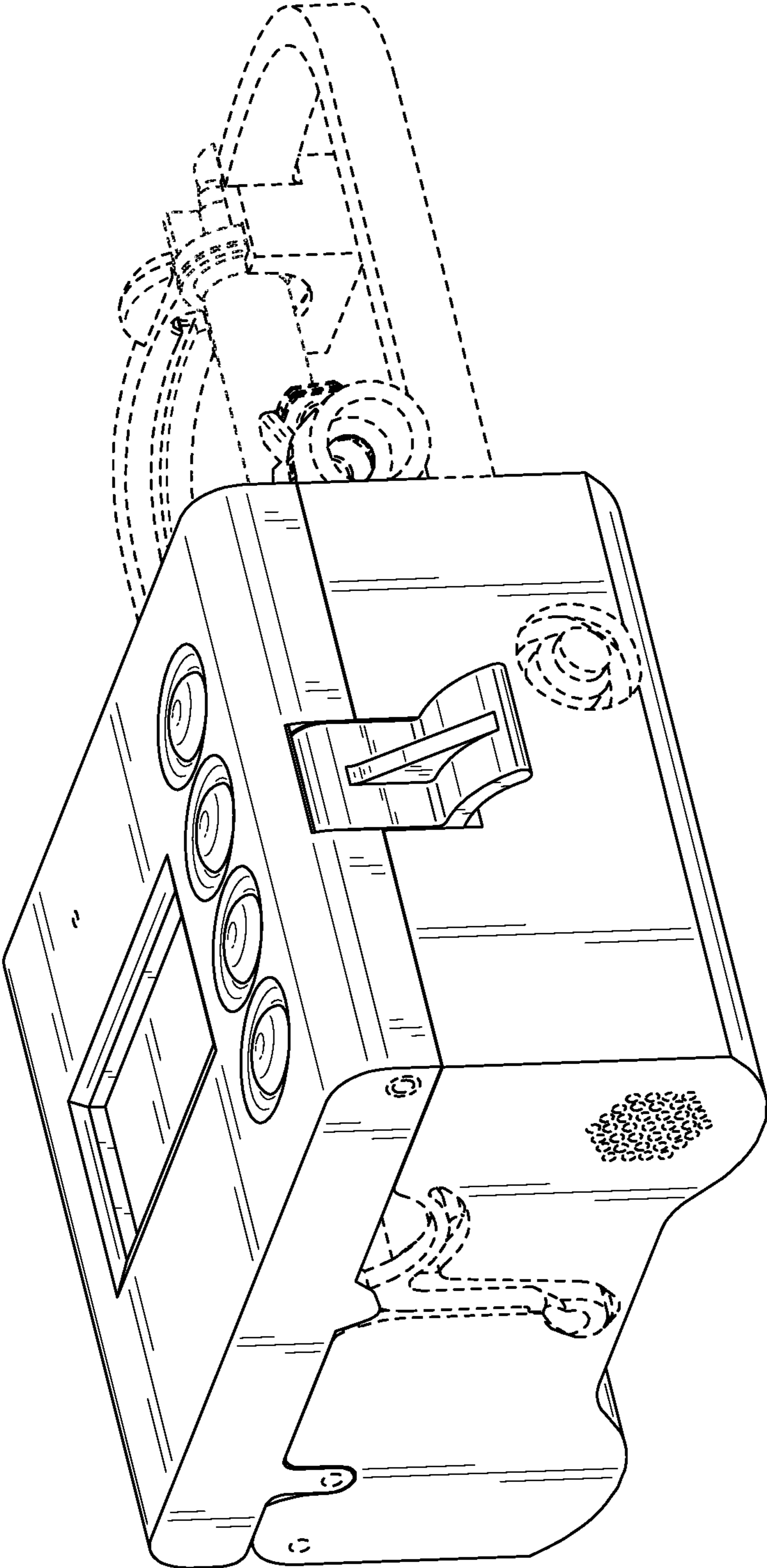

FIG. 1

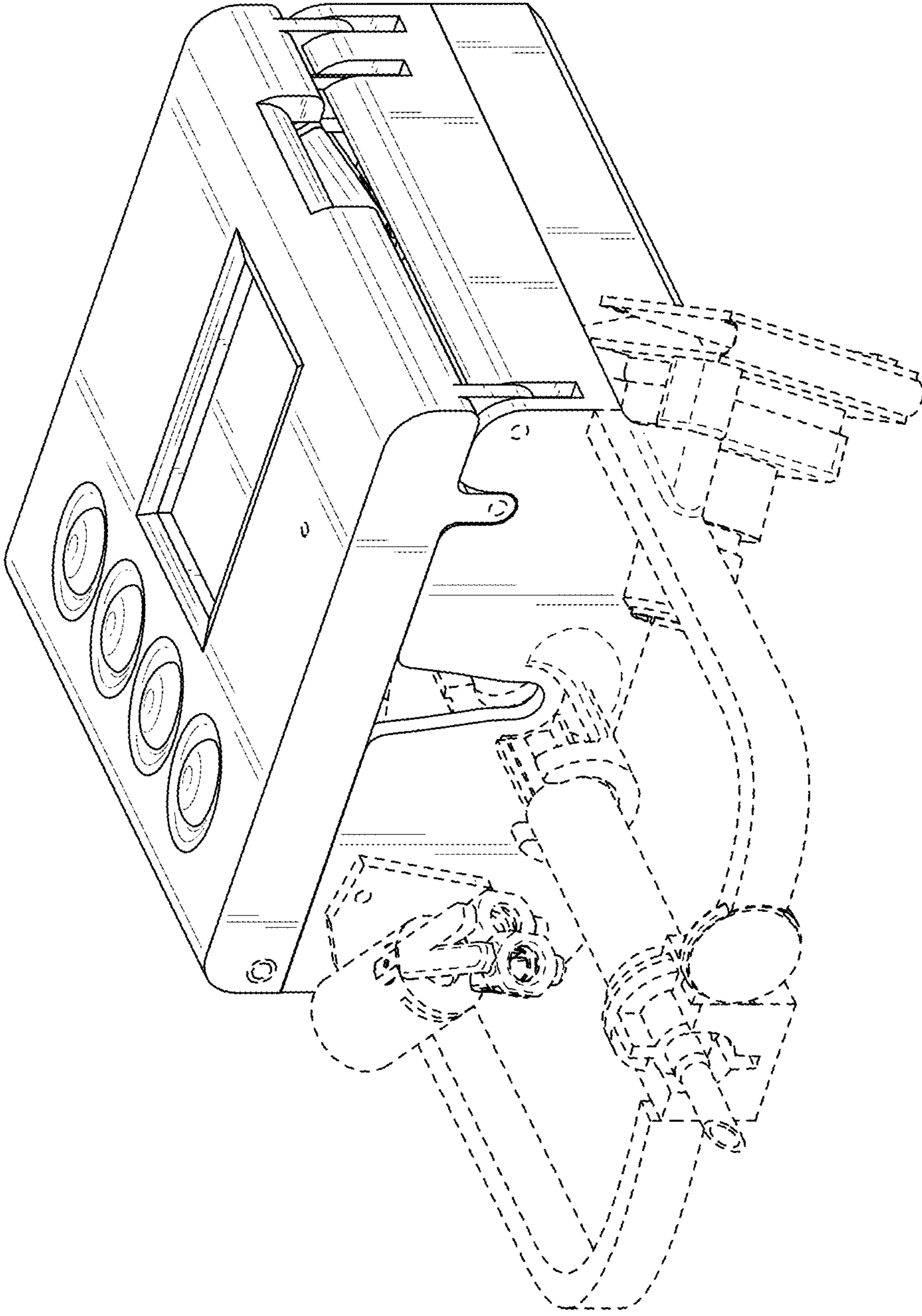

FIG. 2

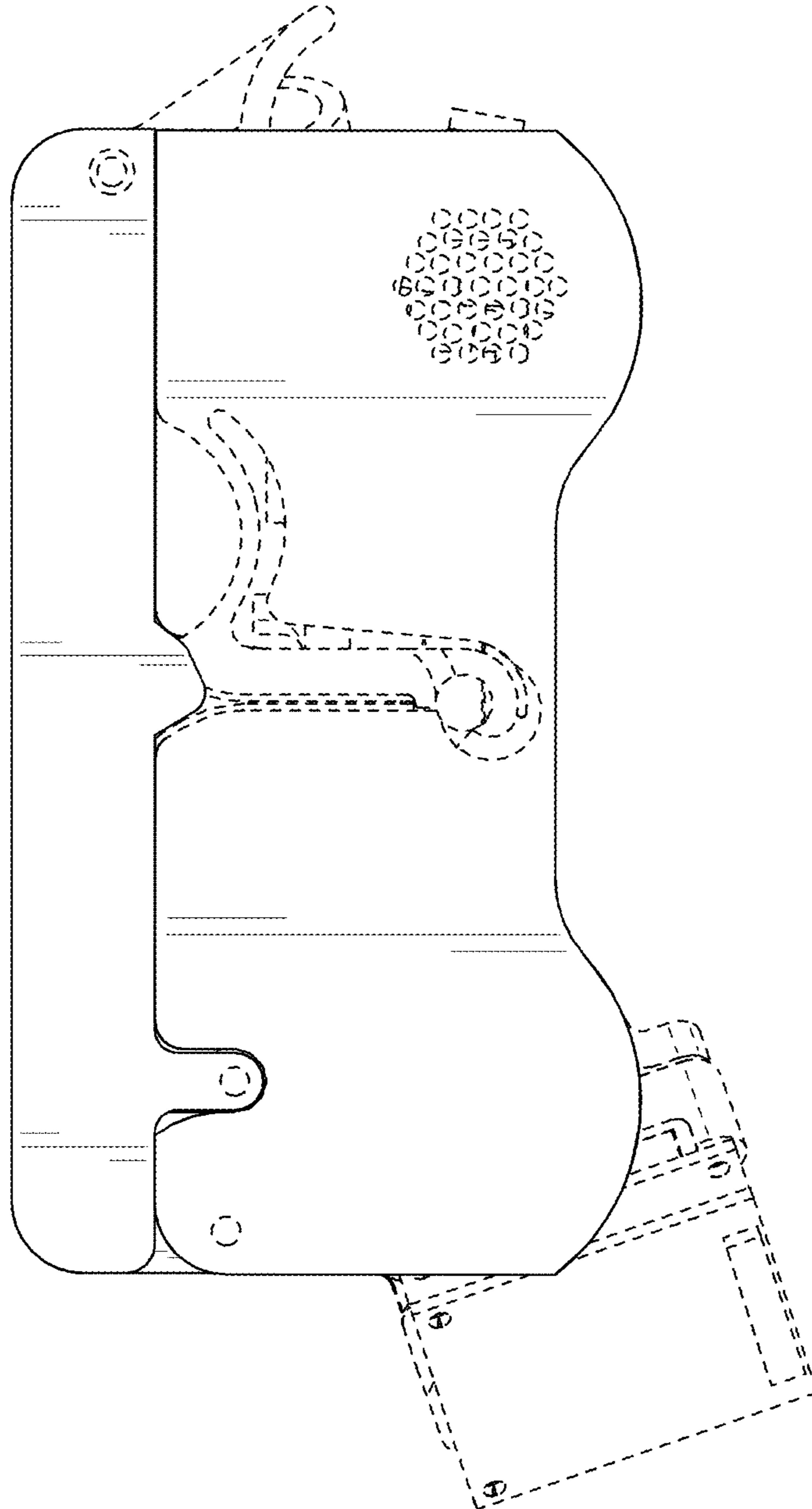

FIG. 3

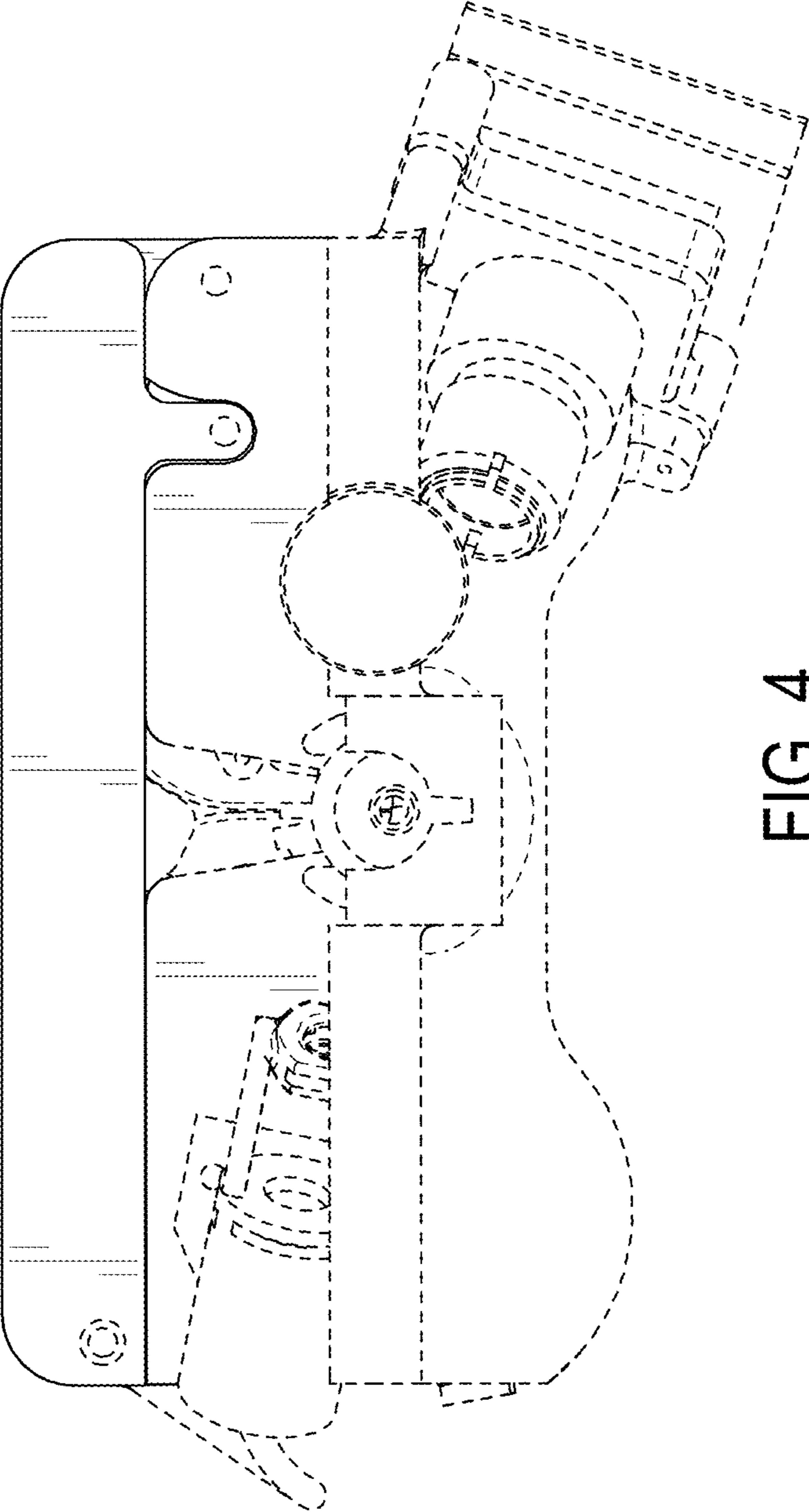

FIG. 4

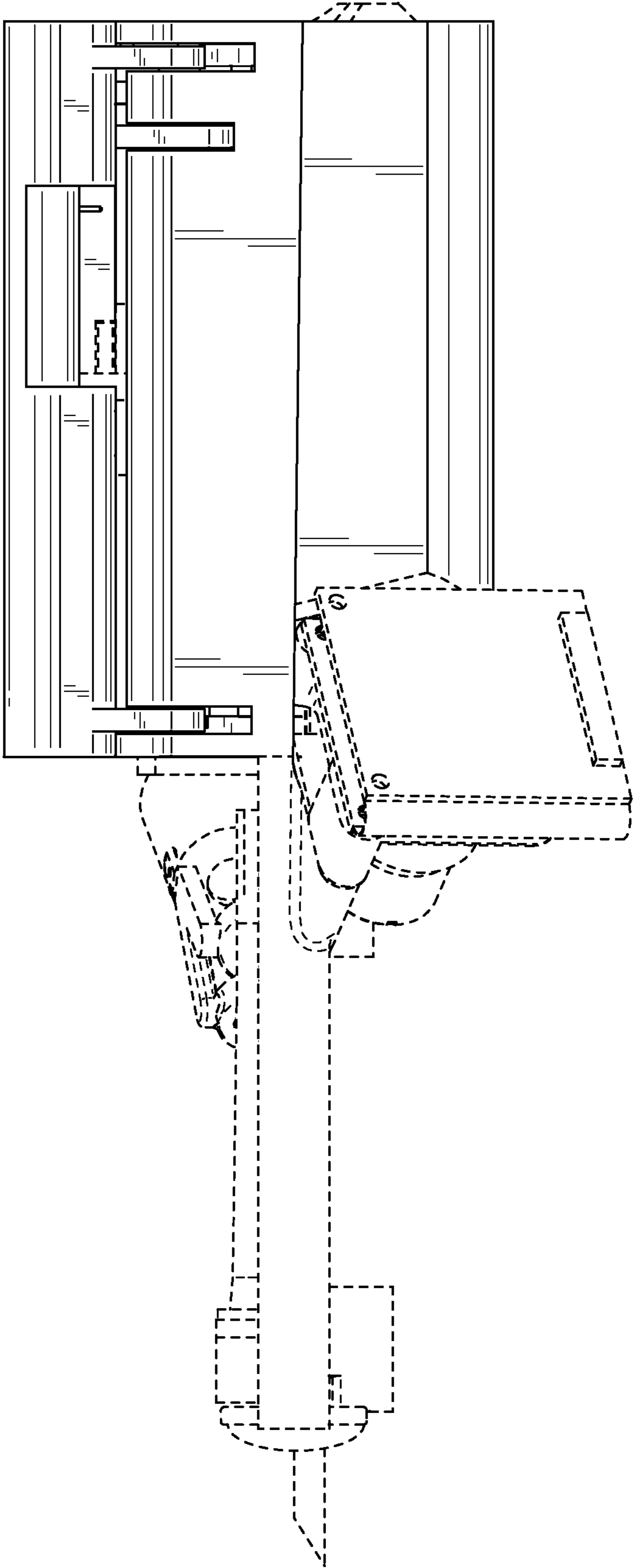

FIG. 5

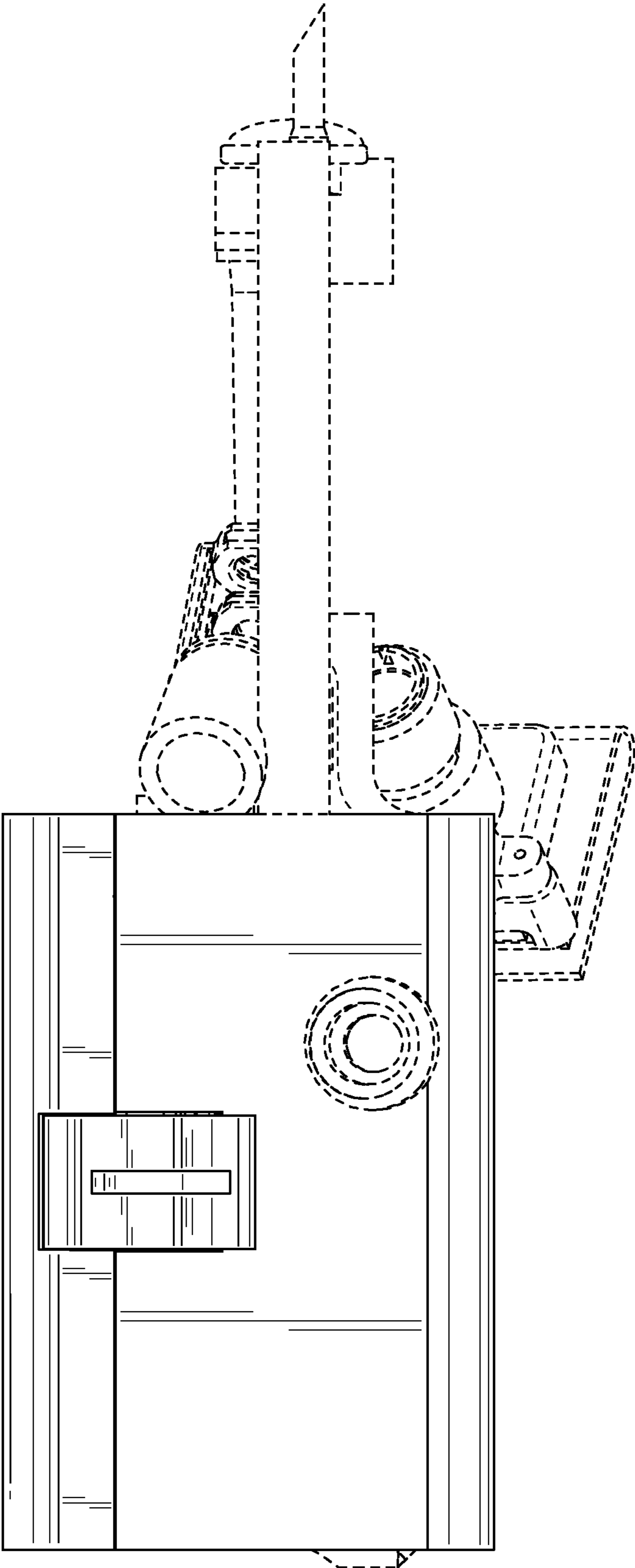

FIG. 6

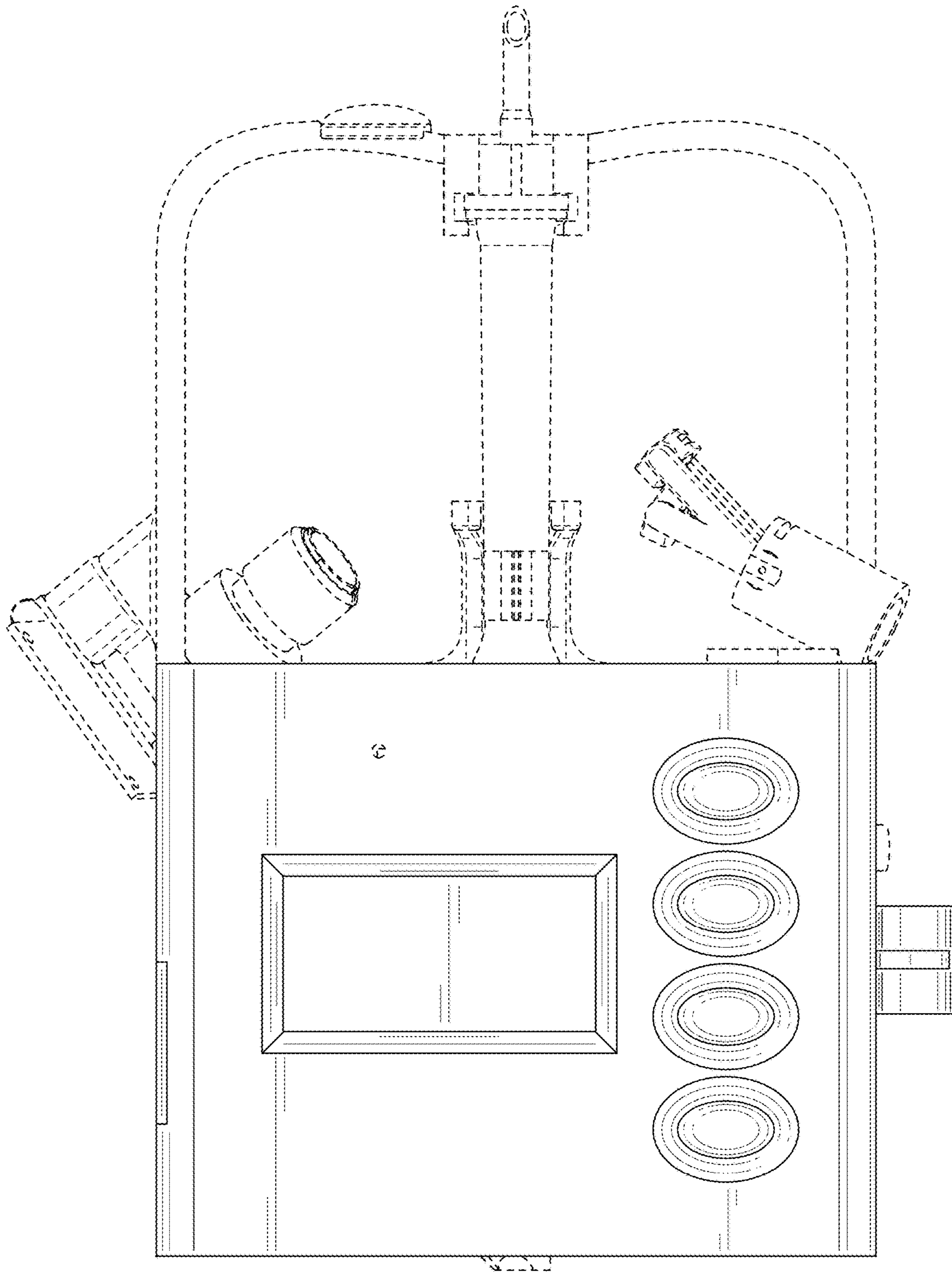

FIG. 7

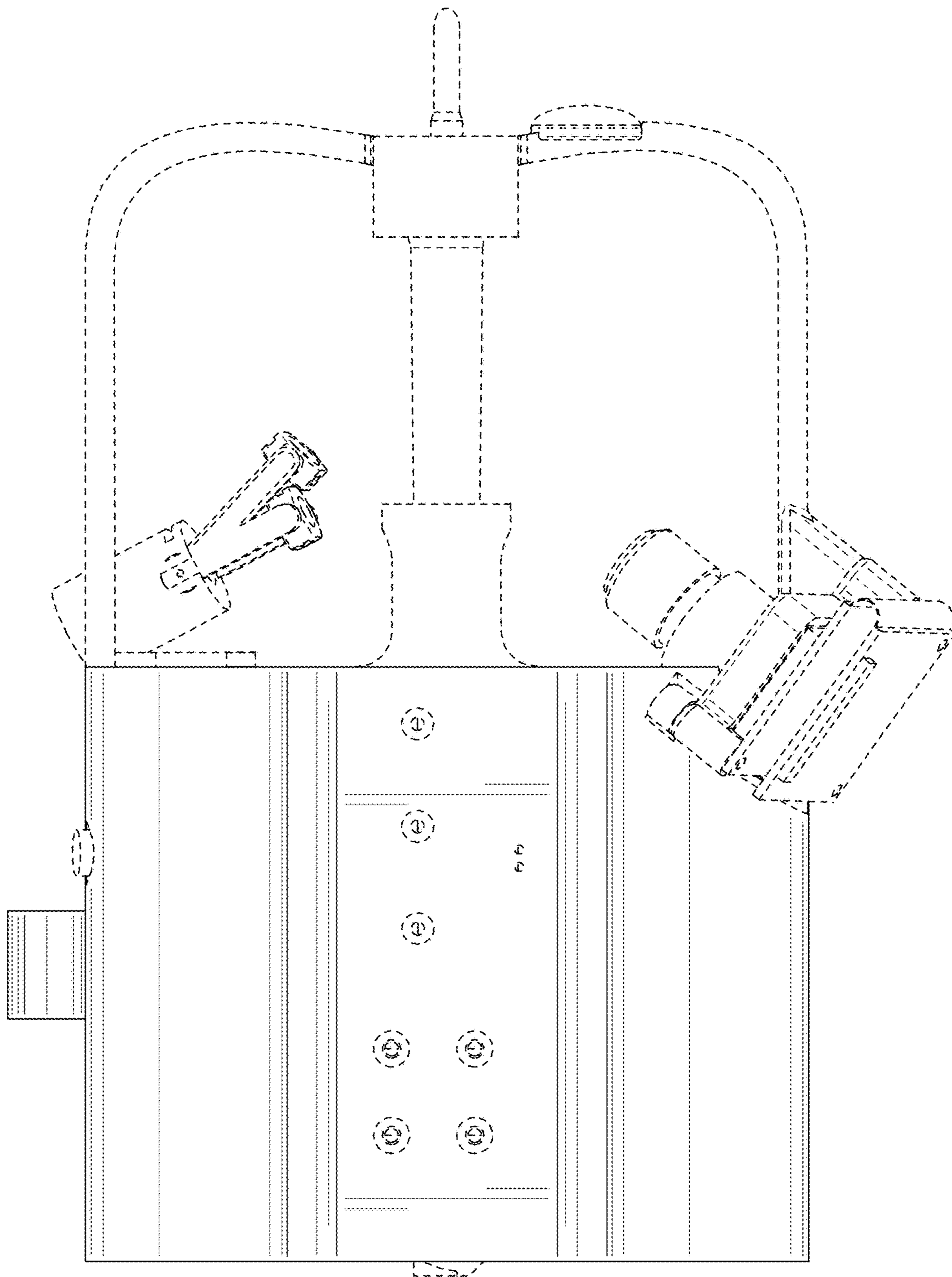

FIG. 8