



US00D802037S

(12) **United States Design Patent** (10) **Patent No.:** **US D802,037 S**  
**Cordingley** (45) **Date of Patent:** **\*\* Nov. 7, 2017**

(54) **GEAR AND AXLE COMBINATION**

(71) Applicant: **Christopher Cordingley**, Los Angeles, CA (US)

(72) Inventor: **Christopher Cordingley**, Los Angeles, CA (US)

(\*\*) Term: **15 Years**

(21) Appl. No.: **29/529,884**

(22) Filed: **Jun. 11, 2015**

(51) **LOC (10) Cl.** ..... **15-09**

(52) **U.S. Cl.**  
USPC ..... **D15/148**

(58) **Field of Classification Search**  
USPC ..... D15/148, 149  
CPC . F16H 1/16; F16H 48/08; F16H 48/40; F16H 2048/085; F16H 2048/385; F16H 2048/423; F16H 2048/426  
See application file for complete search history.

(56) **References Cited**

**U.S. PATENT DOCUMENTS**

1,761,922	A *	6/1930	Hutchinson	.....	F16H 1/16 475/229
1,945,598	A *	2/1934	Cole	.....	B23Q 5/142 82/143
2,555,003	A *	5/1951	Rhoads	.....	B61C 17/08 184/11.1
4,693,431	A *	9/1987	Kataoka	.....	B65H 18/106 242/413.1
6,527,663	B2 *	3/2003	Ballinger	.....	F16H 48/06 475/230
6,535,793	B2 *	3/2003	Allard	.....	B25J 9/1689 318/628
6,749,147	B2 *	6/2004	Heuser	.....	B65H 75/246 242/530.3
D527,738	S *	9/2006	Pearson, Sr.	.....	D15/5

D536,173	S *	2/2007	Hicks	.....	D3/318
D552,691	S *	10/2007	Tak	.....	D21/480
D579,958	S *	11/2008	Lulla	.....	D15/148
D592,255	S *	5/2009	Tak	.....	D21/480
D657,043	S *	4/2012	Lulla	.....	D24/110
8,414,448	B2 *	4/2013	Madge	.....	F16C 39/02 475/331
9,199,323	B2 *	12/2015	Marx	.....	B23F 5/163

\* cited by examiner

*Primary Examiner* — Patricia Palasik

(74) *Attorney, Agent, or Firm* — James A. Italia; Italia IP

(57) **CLAIM**

The ornamental design for a gear and axle combination, as shown and described.

**DESCRIPTION**

FIG. 1 is a perspective view of the gear and axle combination showing my new design;  
 FIG. 2 is a front view thereof;  
 FIG. 3 is a rear view thereof;  
 FIG. 4 is a right side view thereof;  
 FIG. 5 is a left side view thereof;  
 FIG. 6 is a top plan view thereof;  
 FIG. 7 is a bottom plan view thereof;  
 FIG. 8 is an exploded view of the gear and axle combination design shown in FIG. 1;  
 FIG. 9 is a perspective view of the gear and axle combination showing my new design in a second embodiment;  
 FIG. 10 is a front view thereof;  
 FIG. 11 is a rear view thereof;  
 FIG. 12 is a right side view thereof;  
 FIG. 13 is a left side view thereof;  
 FIG. 14 is a top plan view thereof;  
 FIG. 15 is a bottom plan view thereof; and,  
 FIG. 16 is an exploded view of the gear and axle combination design shown in FIG. 9.

**1 Claim, 8 Drawing Sheets**

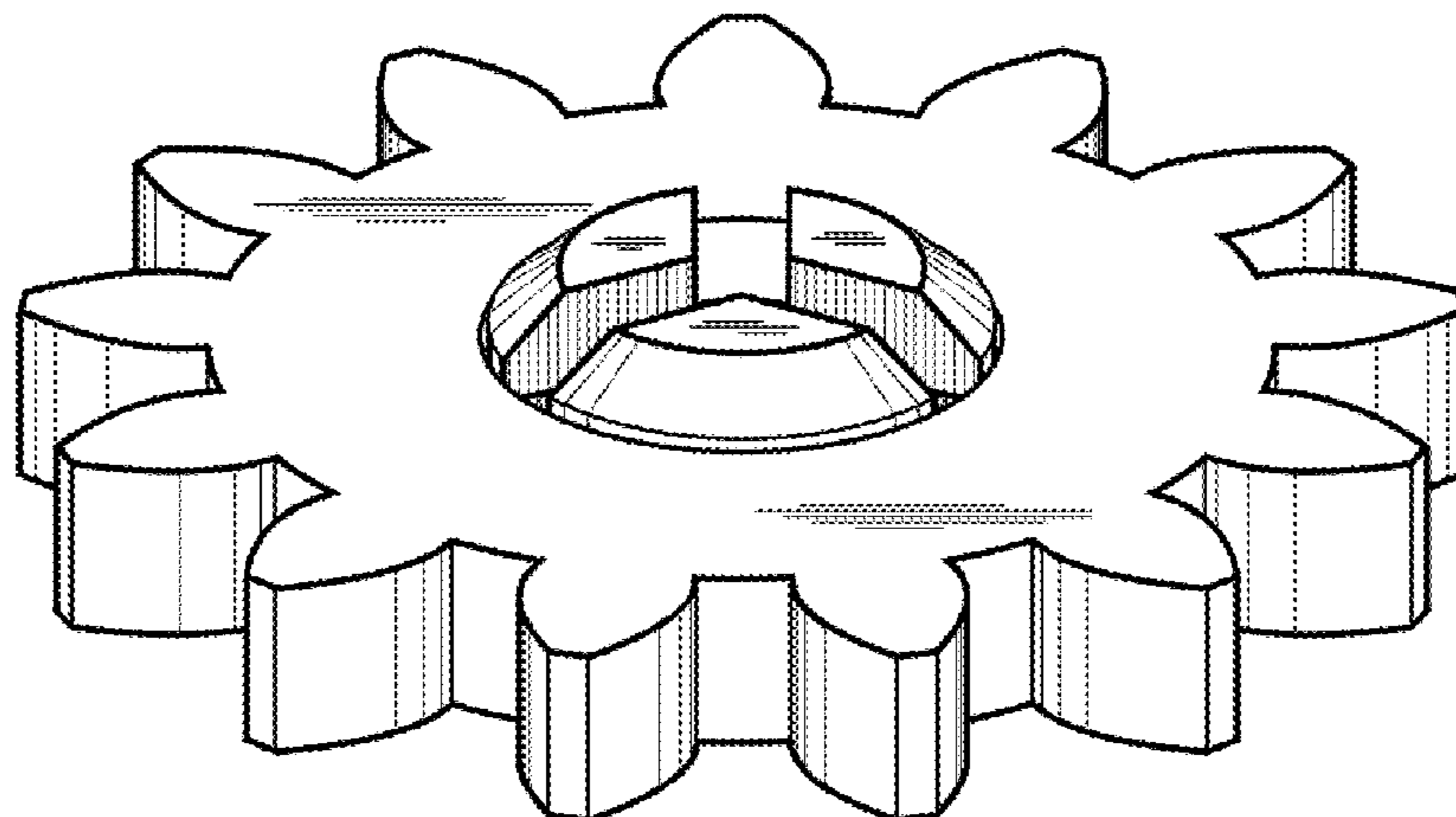

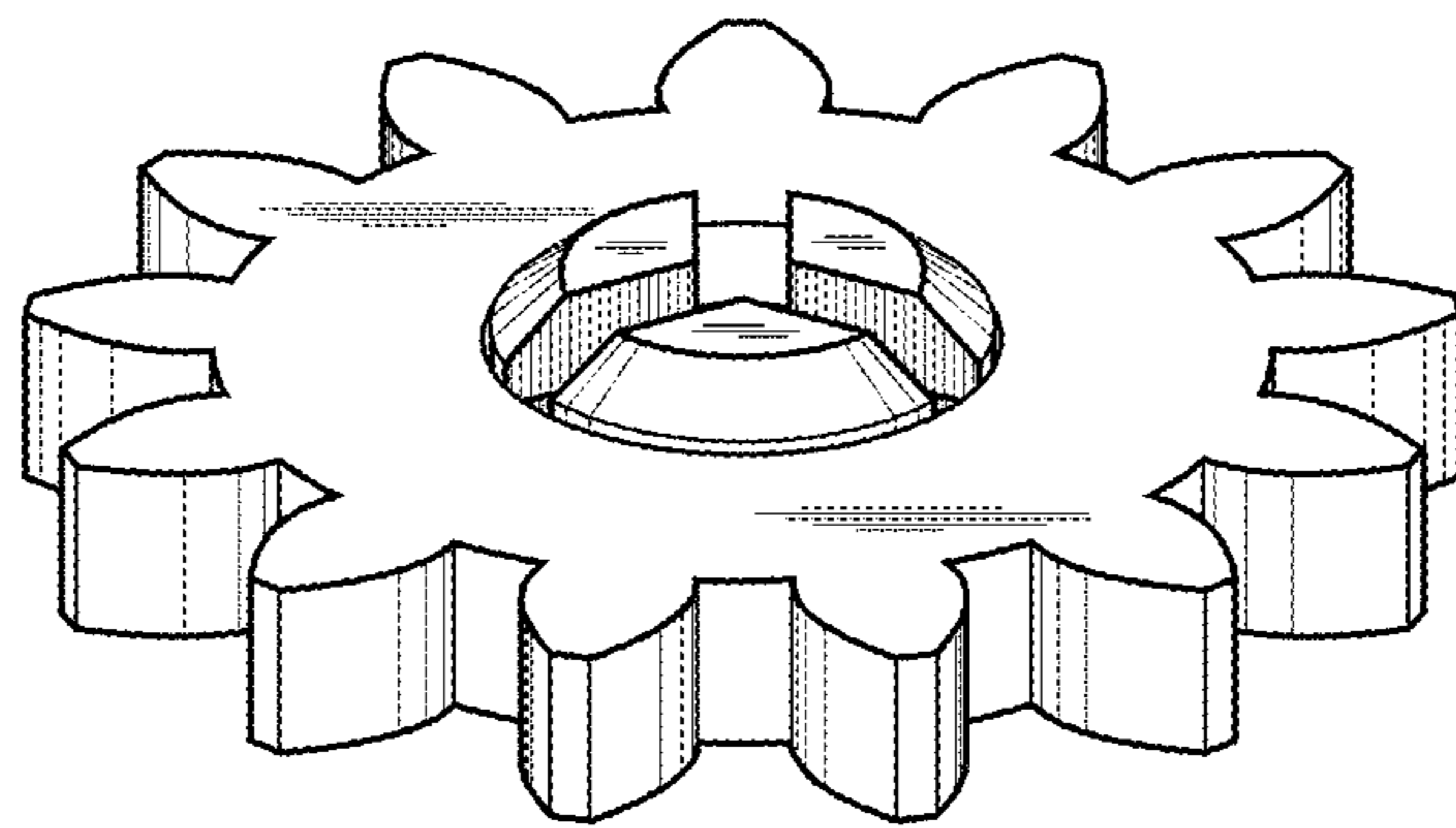

FIG. 1

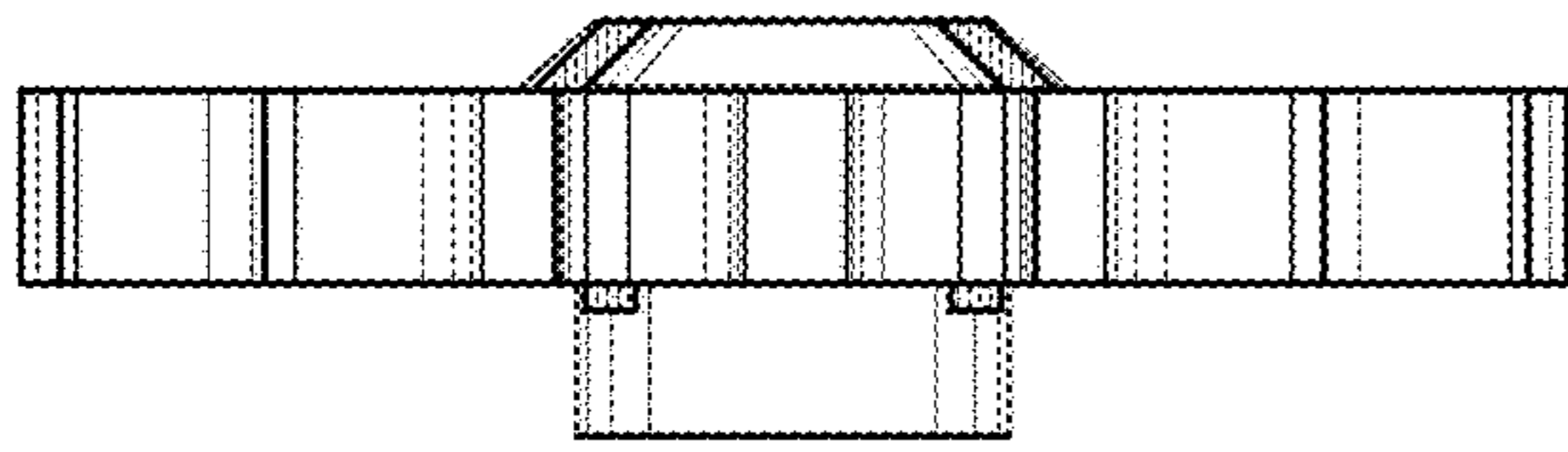

FIG. 2

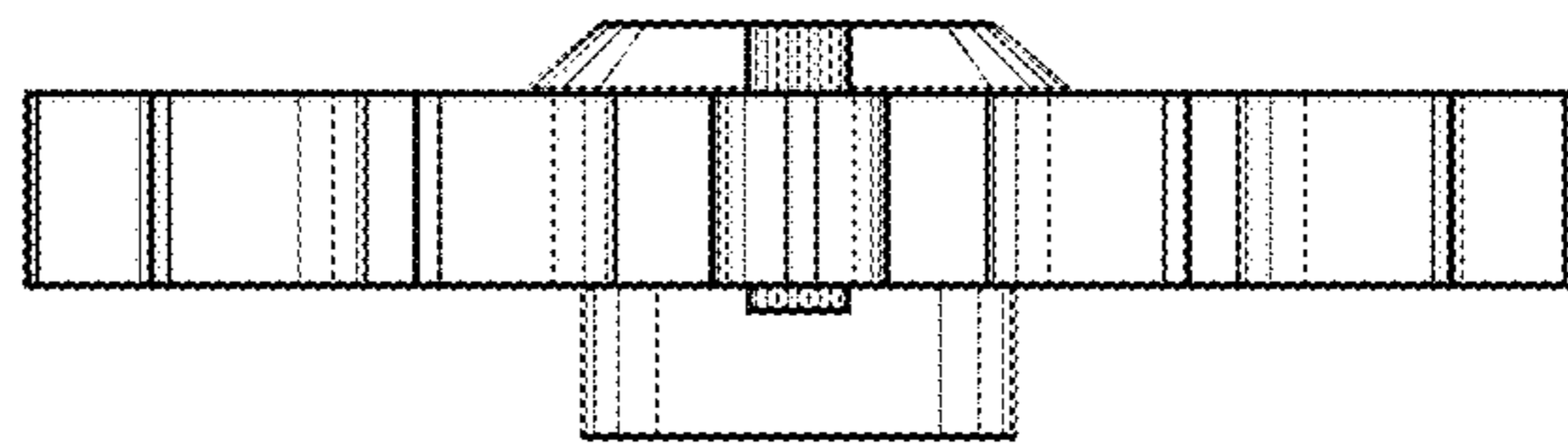

FIG. 3

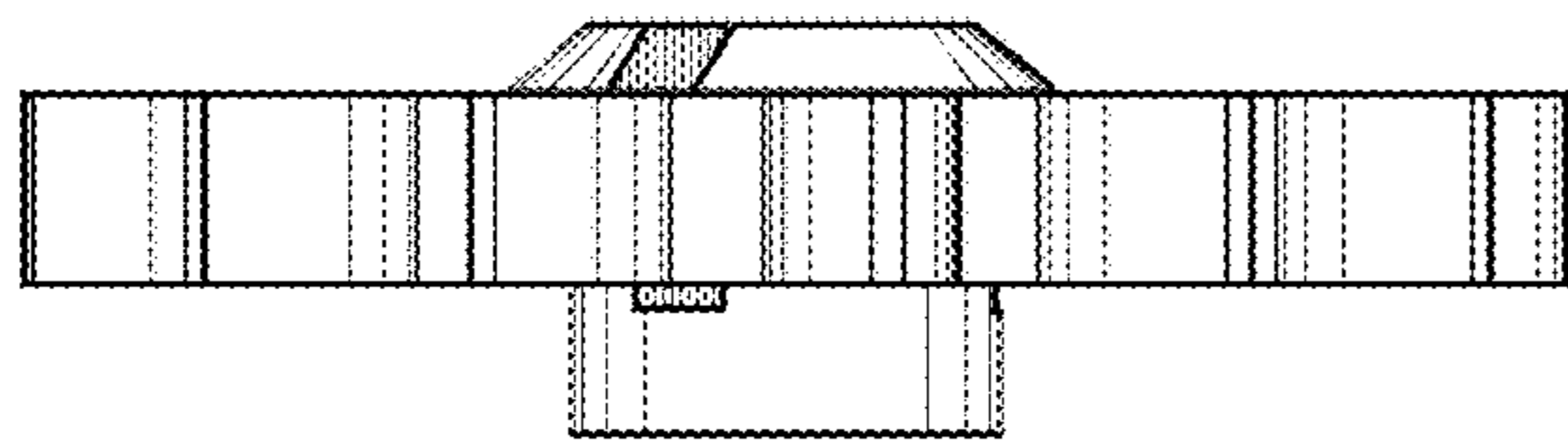

FIG. 4

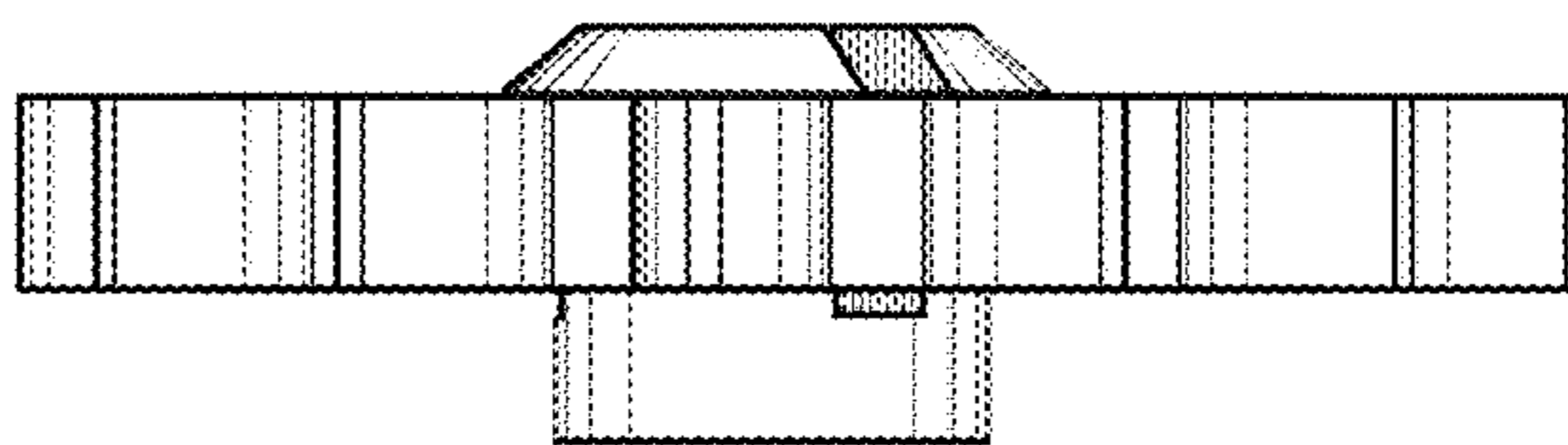

FIG. 5

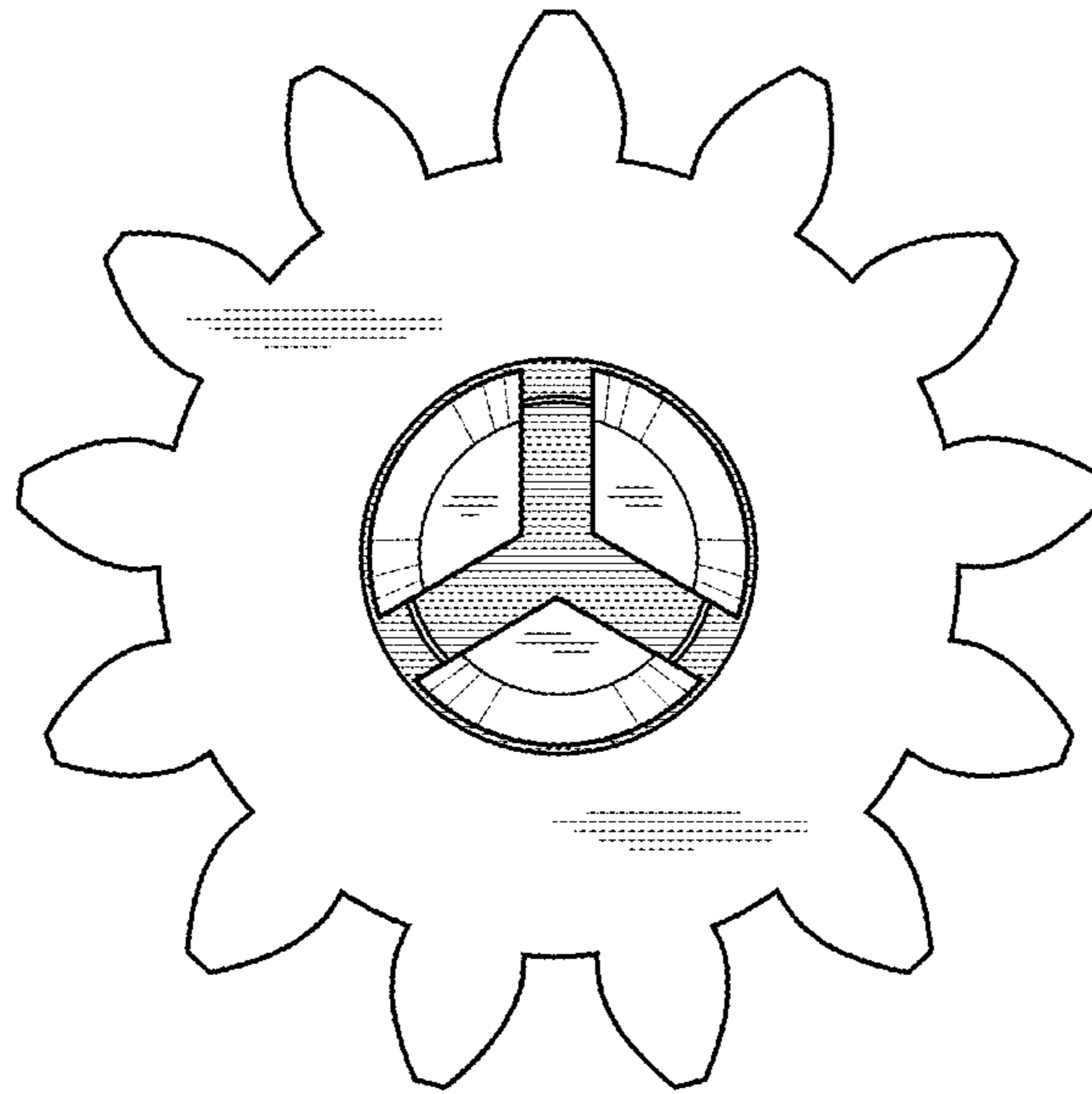

FIG. 6

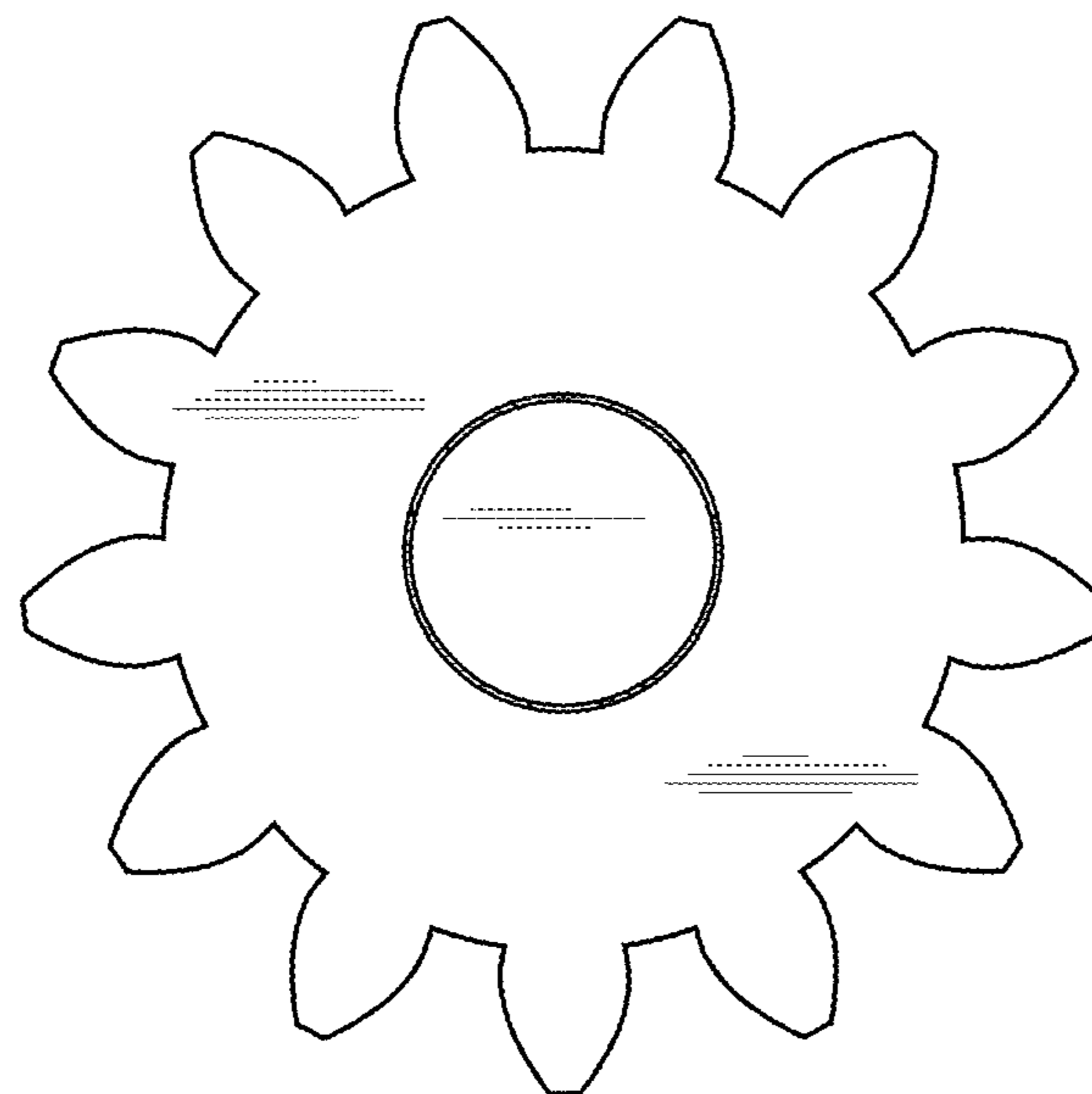

FIG. 7

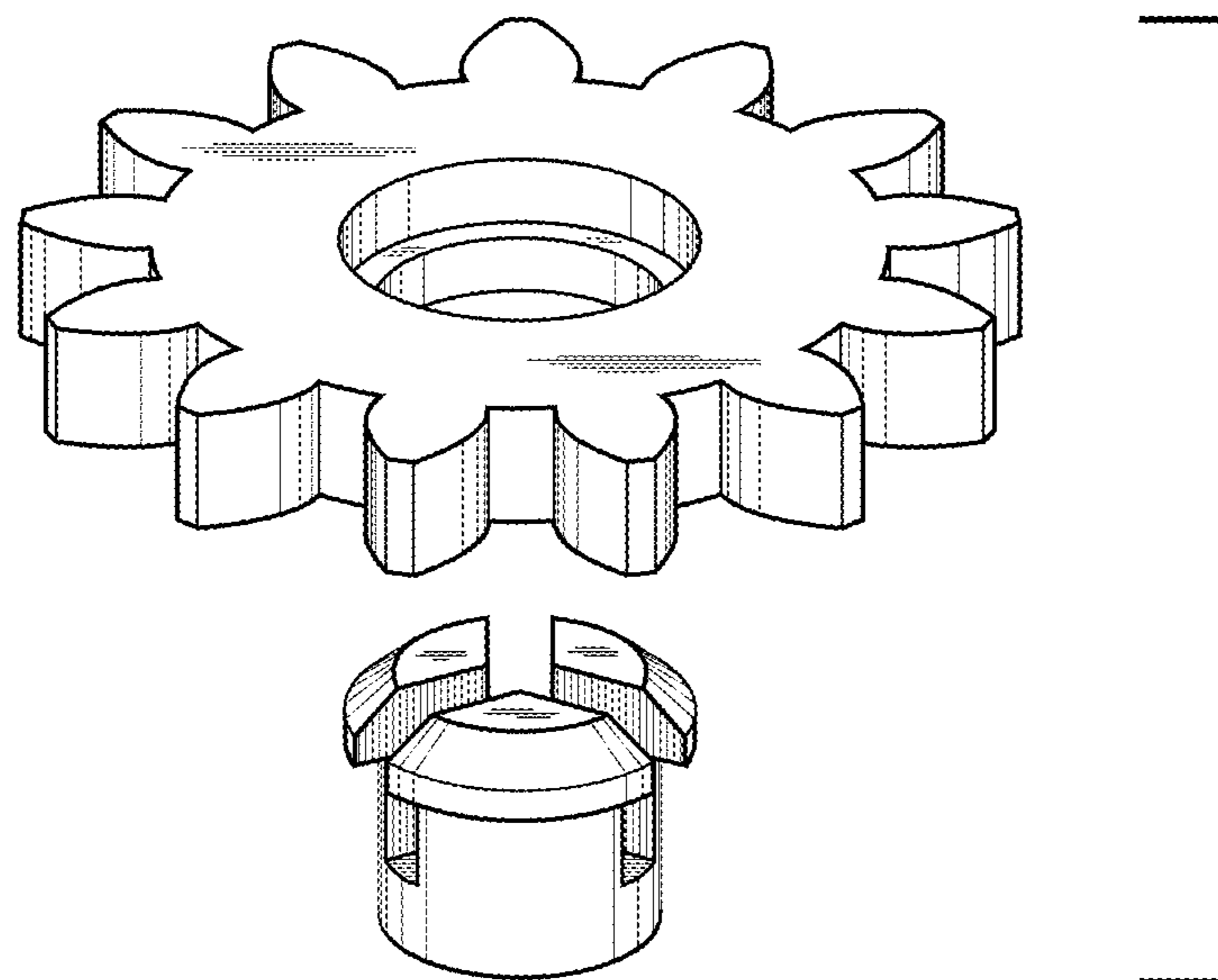

FIG. 8

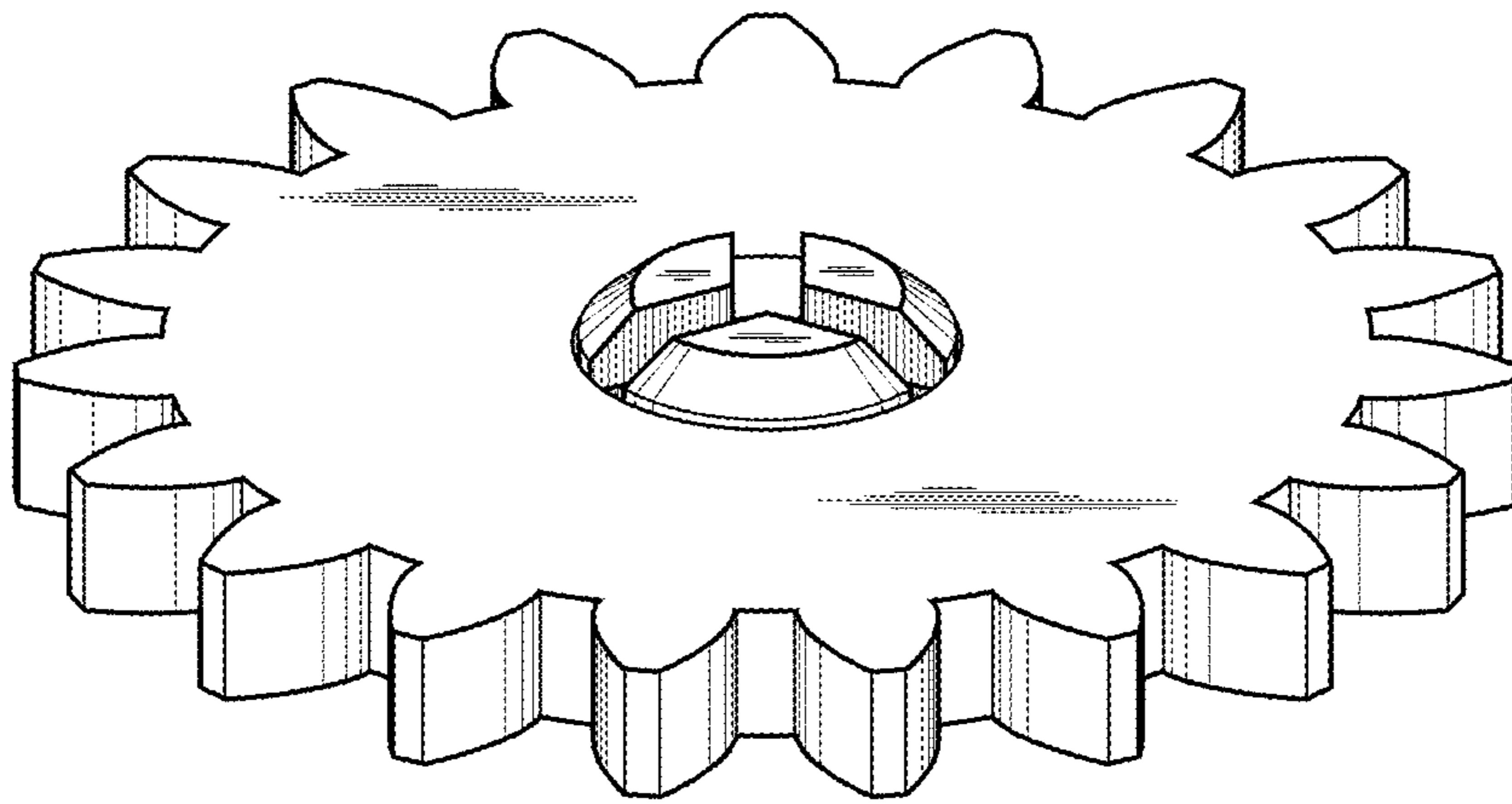

FIG. 9



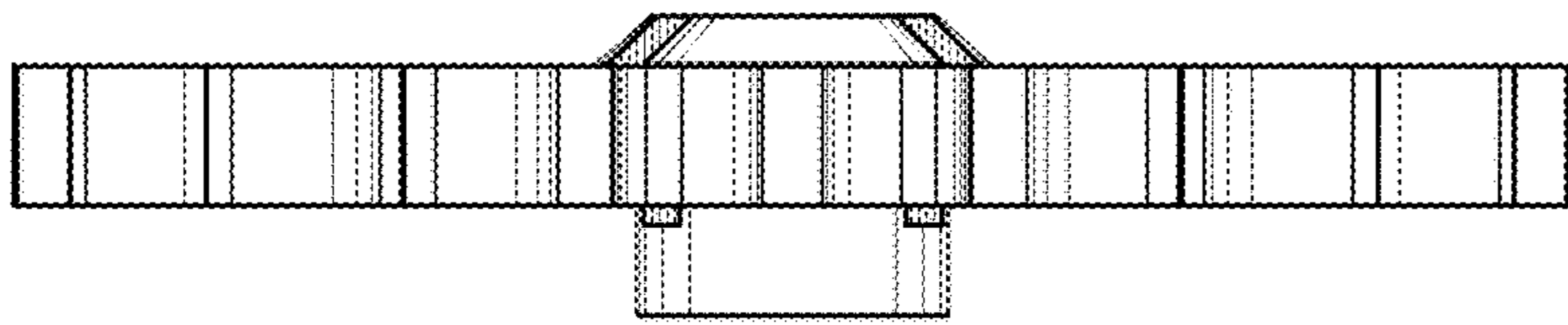

FIG. 10

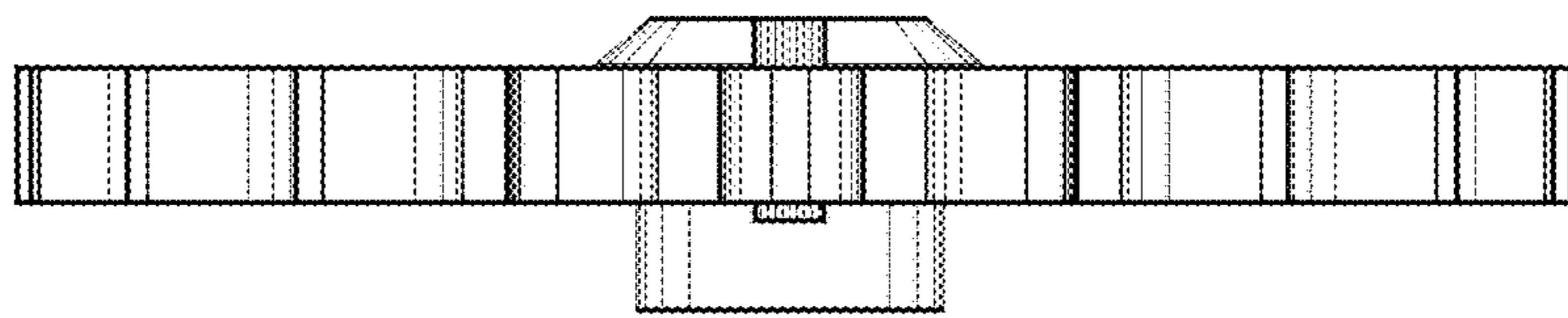

FIG. 11

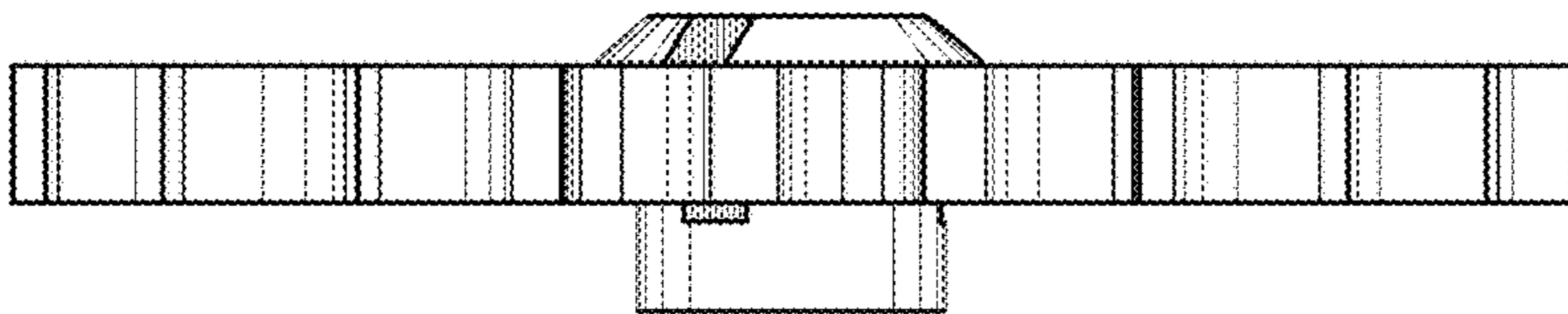

FIG. 12

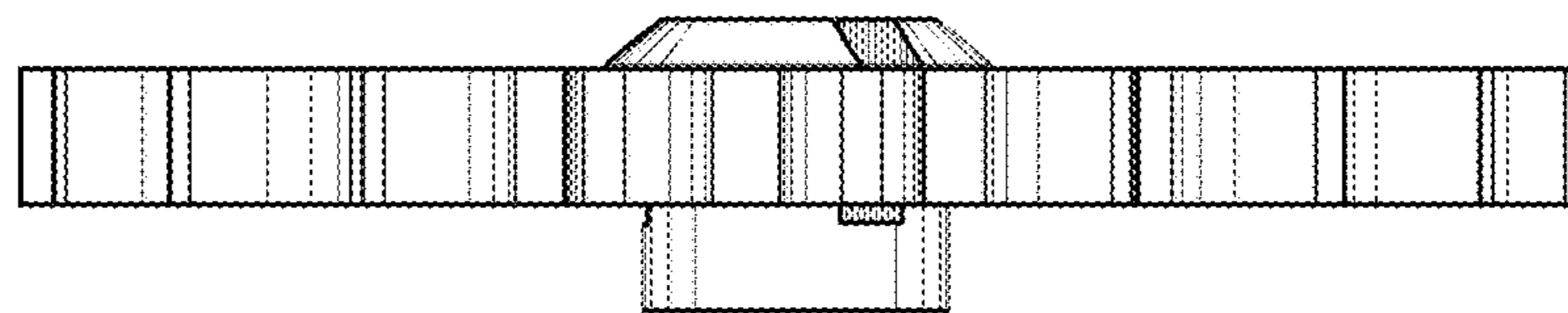

FIG. 13

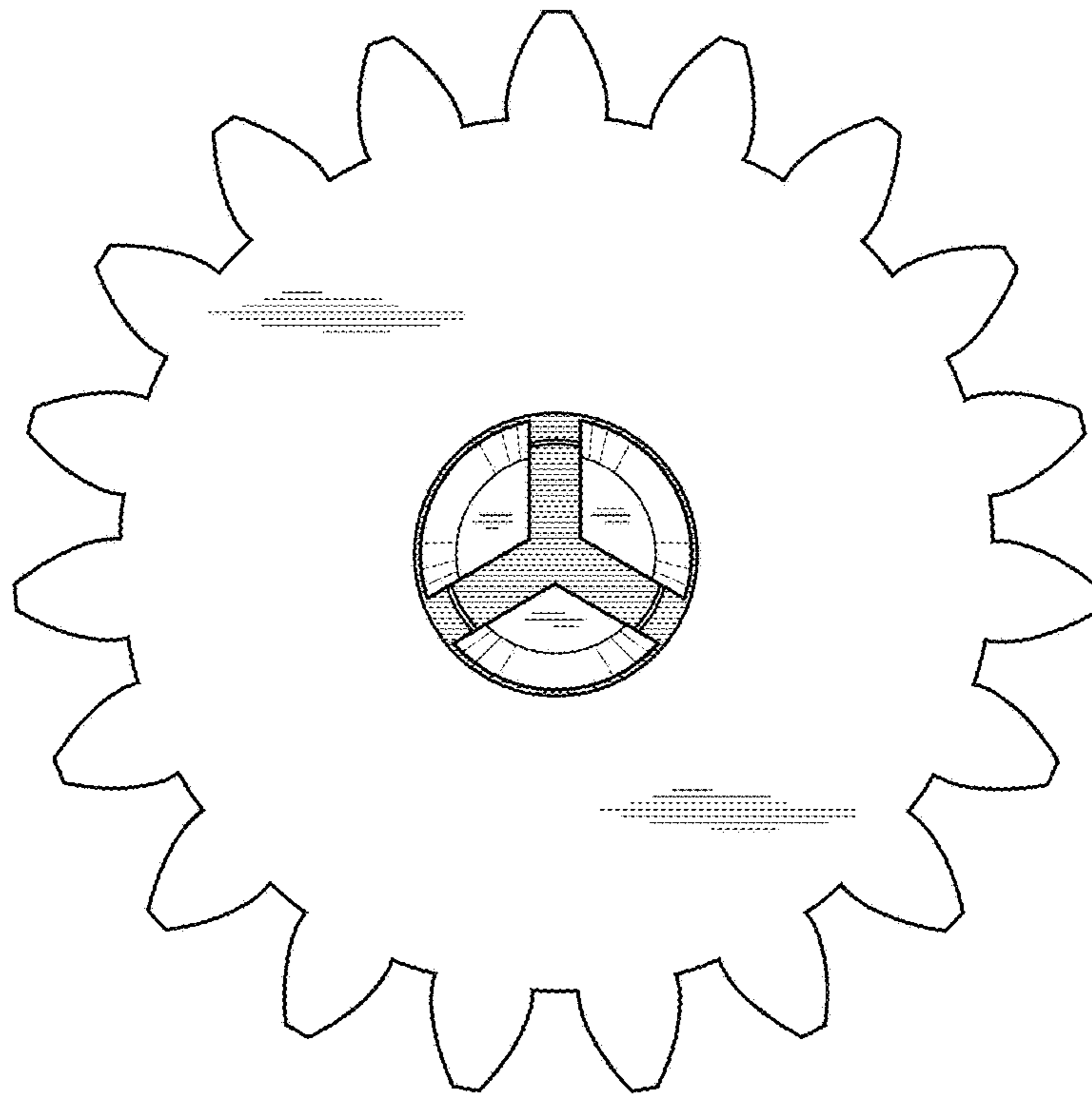

FIG. 14

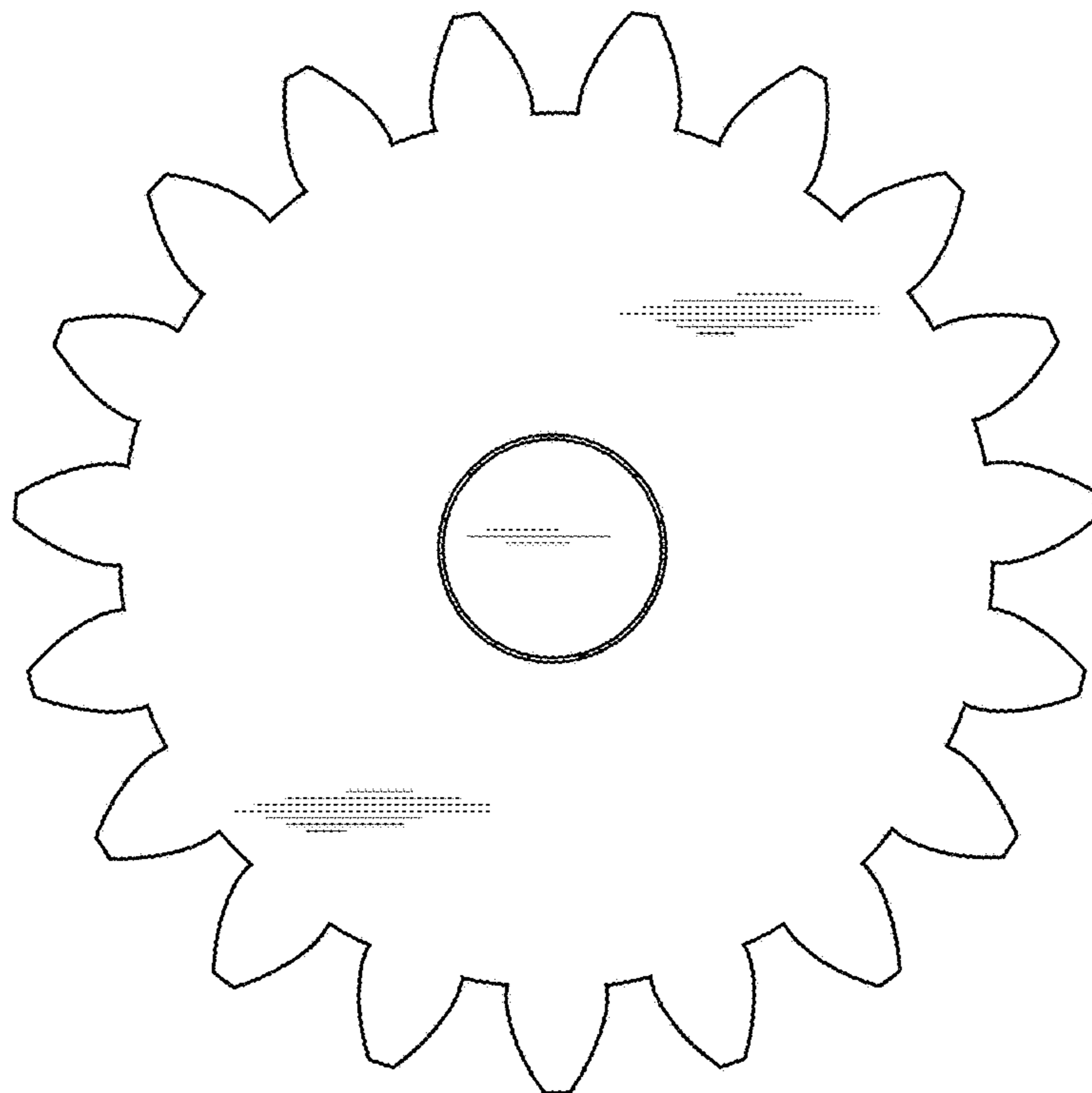

FIG. 15



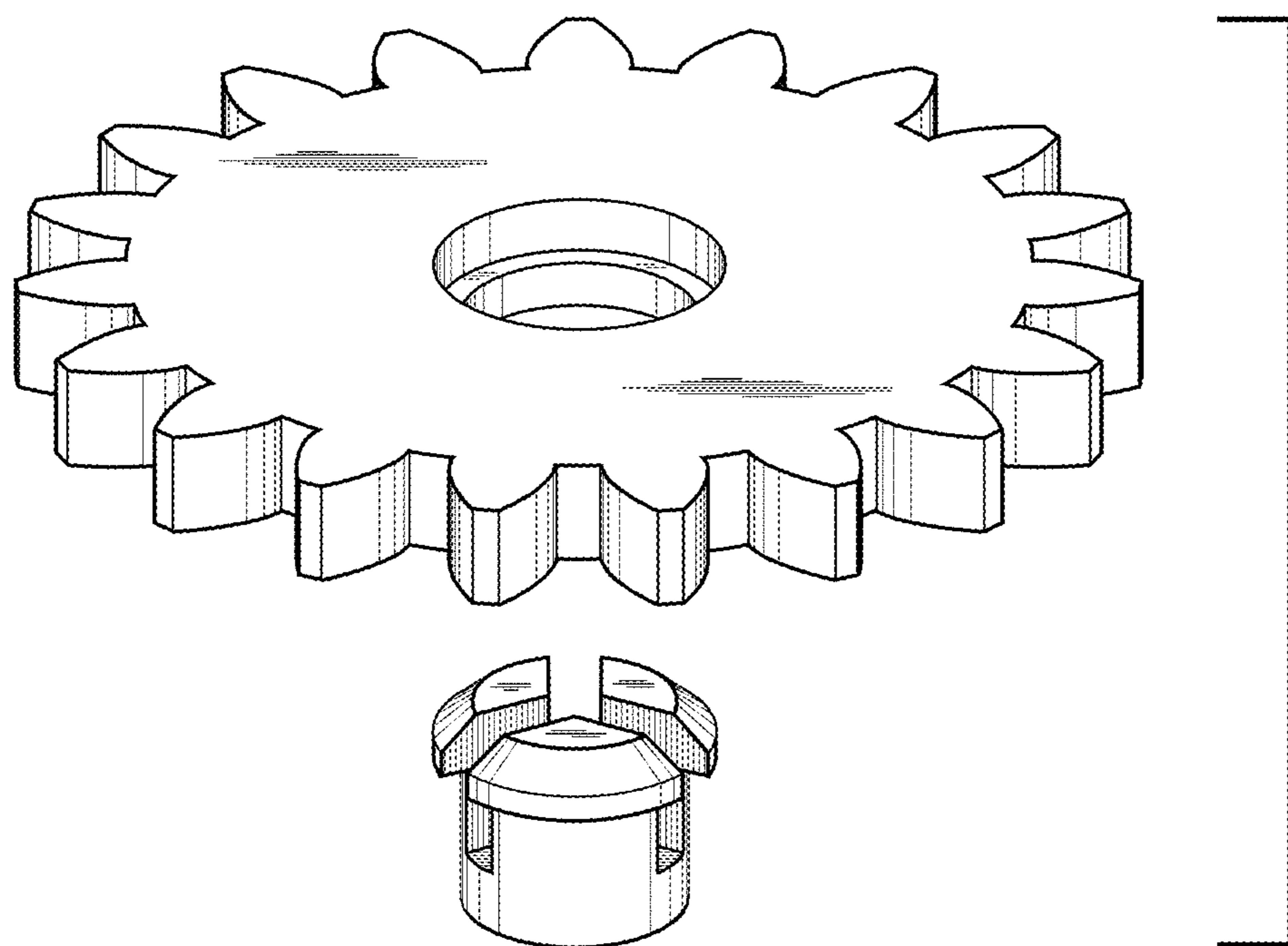

FIG. 16