



US00D801876S

(12) **United States Design Patent**
Greiner

(10) **Patent No.:** **US D801,876 S**

(45) **Date of Patent:** **** Nov. 7, 2017**

(54) **BICYCLE DRIVE UNIT**
(71) Applicant: **Robert Bosch GmbH**, Stuttgart (DE)
(72) Inventor: **Rinaldo Greiner**, Reutlingen (DE)
(73) Assignee: **Robert Bosch GmbH**, Stuttgart (DE)

(**) Term: **15 Years**

(21) Appl. No.: **29/555,680**

(22) Filed: **Feb. 24, 2016**

(30) **Foreign Application Priority Data**

Aug. 24, 2015 (EM) 002759464
Sep. 15, 2015 (EM) 002772665

(51) **LOC (10) Cl.** **12-11**

(52) **U.S. Cl.**
USPC **D12/123**

(58) **Field of Classification Search**
USPC D12/111, 122-127; 474/77, 80, 116,
474/118, 152, 155-158, 160-164, 202;
280/288.4, 304.3, 304.4; 74/594.2
CPC F16H 1/00; F16H 1/28; F16H 7/06; F16H
55/30; F16H 55/303; B62M 9/105
See application file for complete search history.

(56) **References Cited**

U.S. PATENT DOCUMENTS

D520,920 S * 5/2006 Okada D12/123
D532,342 S * 11/2006 Arakawa D12/123
D553,055 S * 10/2007 Tokumoto D12/123
D555,048 S * 11/2007 Hanamura D12/123
D580,303 S * 11/2008 Okada D12/123
D600,166 S * 9/2009 Tokumoto D12/123
D607,784 S * 1/2010 Gisbert D12/123
7,686,721 B2 * 3/2010 Tabe B62M 9/105
474/116
D625,333 S * 10/2010 Tanaka D12/111
D654,403 S * 2/2012 Kyu D12/111

D675,549 S * 2/2013 Noborio D12/123
8,657,047 B2 * 2/2014 Urabe B62M 6/65
180/220
D720,260 S * 12/2014 Yoshida D12/111
D721,013 S * 1/2015 Fragassi D12/111
D733,009 S * 6/2015 Woods D12/123

(Continued)

Primary Examiner — Darlington Ly

(74) *Attorney, Agent, or Firm* — Maginot, Moore & Beck
LLP

(57) **CLAIM**

The ornamental design for a bicycle drive unit, as shown and described.

DESCRIPTION

Cross reference is made to U.S. design patent application Ser. No. 29/555,684 entitled “Bicycle Drive Unit and Frame Portion” by Rinaldo Greiner, filed on even date herewith; and U.S. design patent application Ser. No. 29/555,686 entitled “Bicycle Drive Unit” by Rinaldo Greiner, filed on even date herewith.

FIG. 1 is a perspective view of a bicycle drive unit showing my new design;

FIG. 2 is a front elevational view showing the design for the bicycle drive unit of FIG. 1;

FIG. 3 is a rear elevational view showing the design for the bicycle drive unit of FIG. 1;

FIG. 4 is a left side elevational view showing the design for the bicycle drive unit of FIG. 1;

FIG. 5 is a right side elevational view showing the design for the bicycle drive unit of FIG. 1;

FIG. 6 is a top plan view showing the design for the bicycle drive unit of FIG. 1; and,

FIG. 7 is a bottom plan view showing the design for the bicycle drive unit of FIG. 1.

The broken lines shown in the drawings illustrate portions of the bicycle drive unit that form no part of the claimed design.

1 Claim, 7 Drawing Sheets

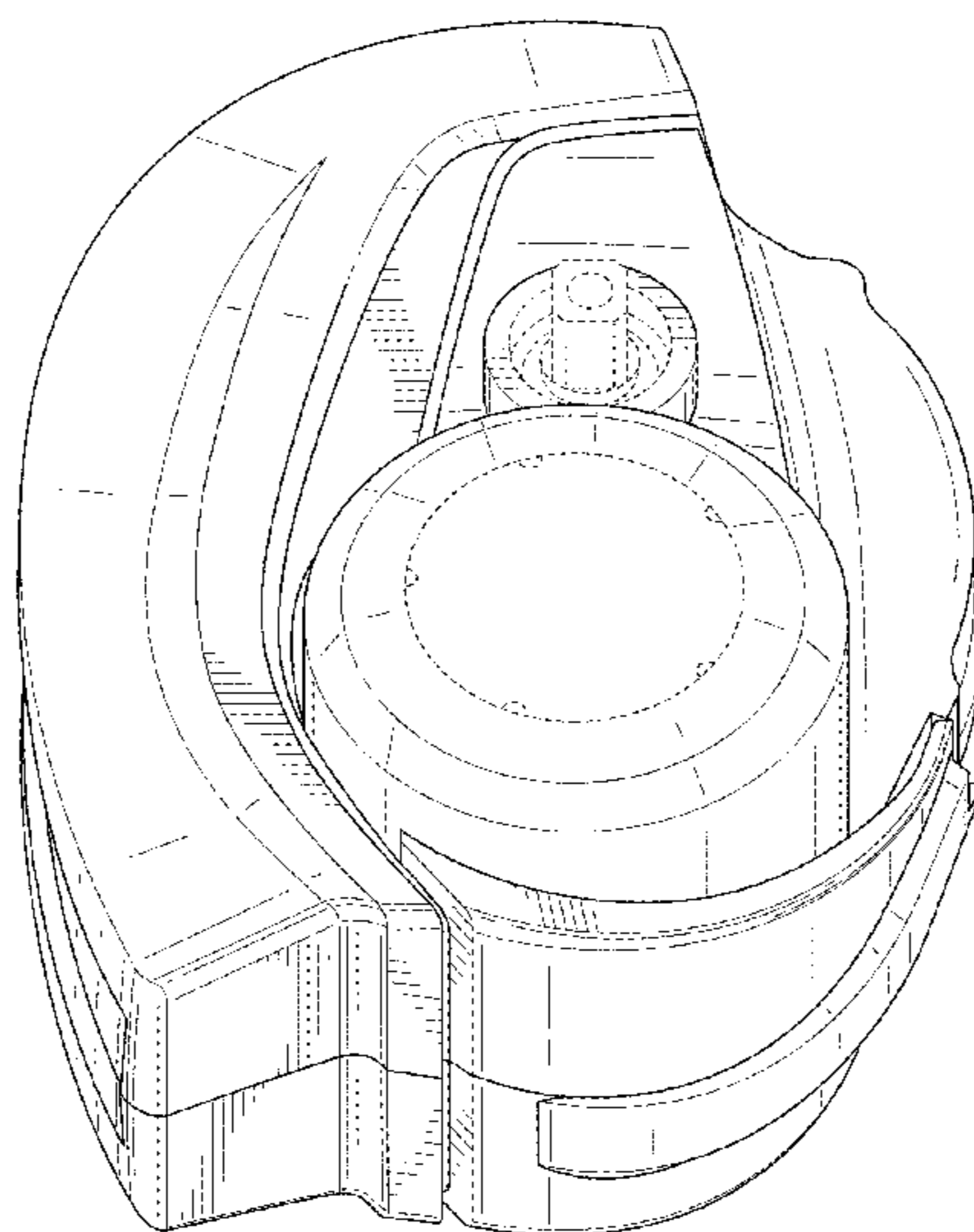

(56)

References Cited

U.S. PATENT DOCUMENTS

2009/0260476 A1* 10/2009 Jordan B62M 11/145
74/577 R
2014/0080651 A1* 3/2014 Kim F16H 1/28
475/149

* cited by examiner

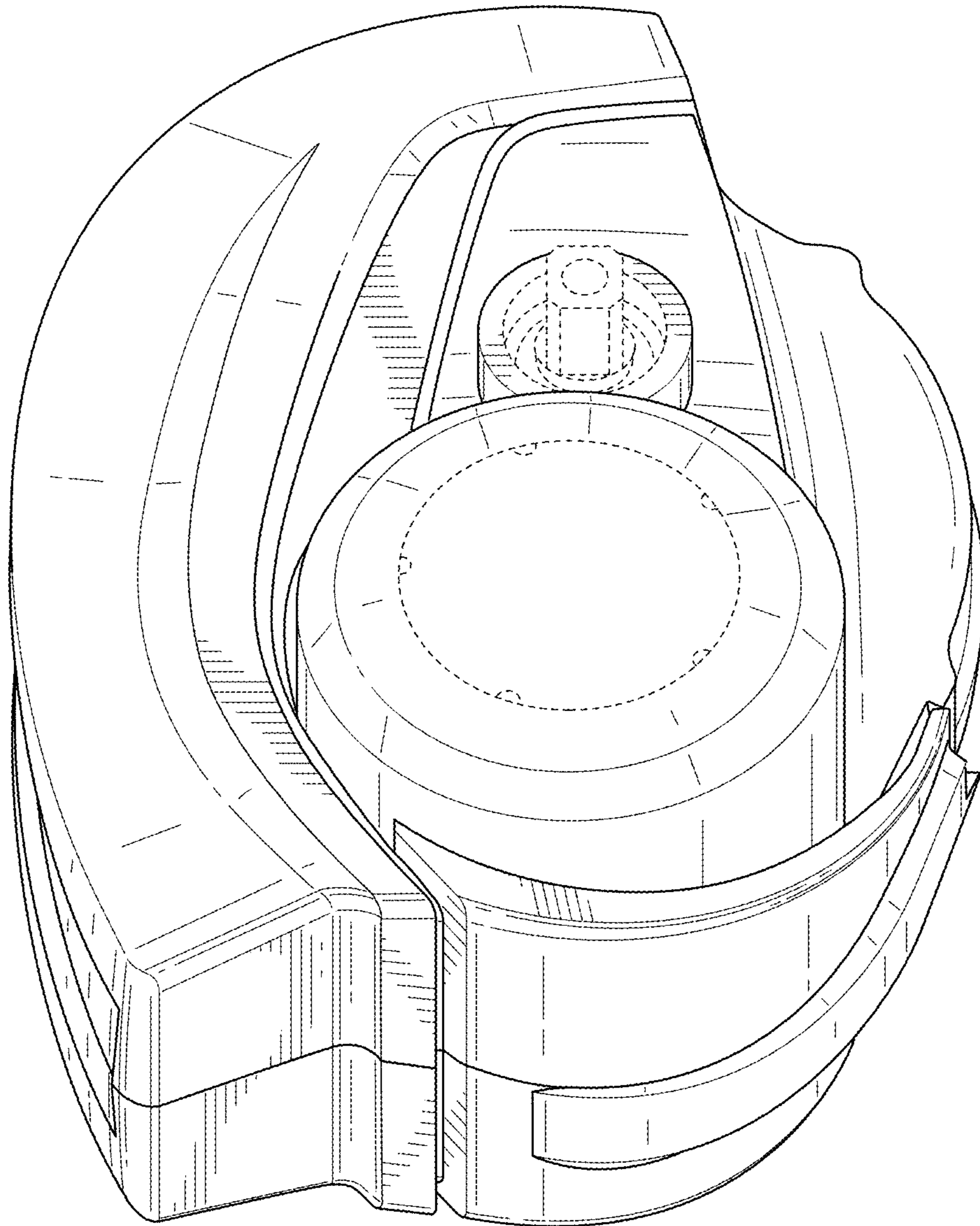

FIG. 1

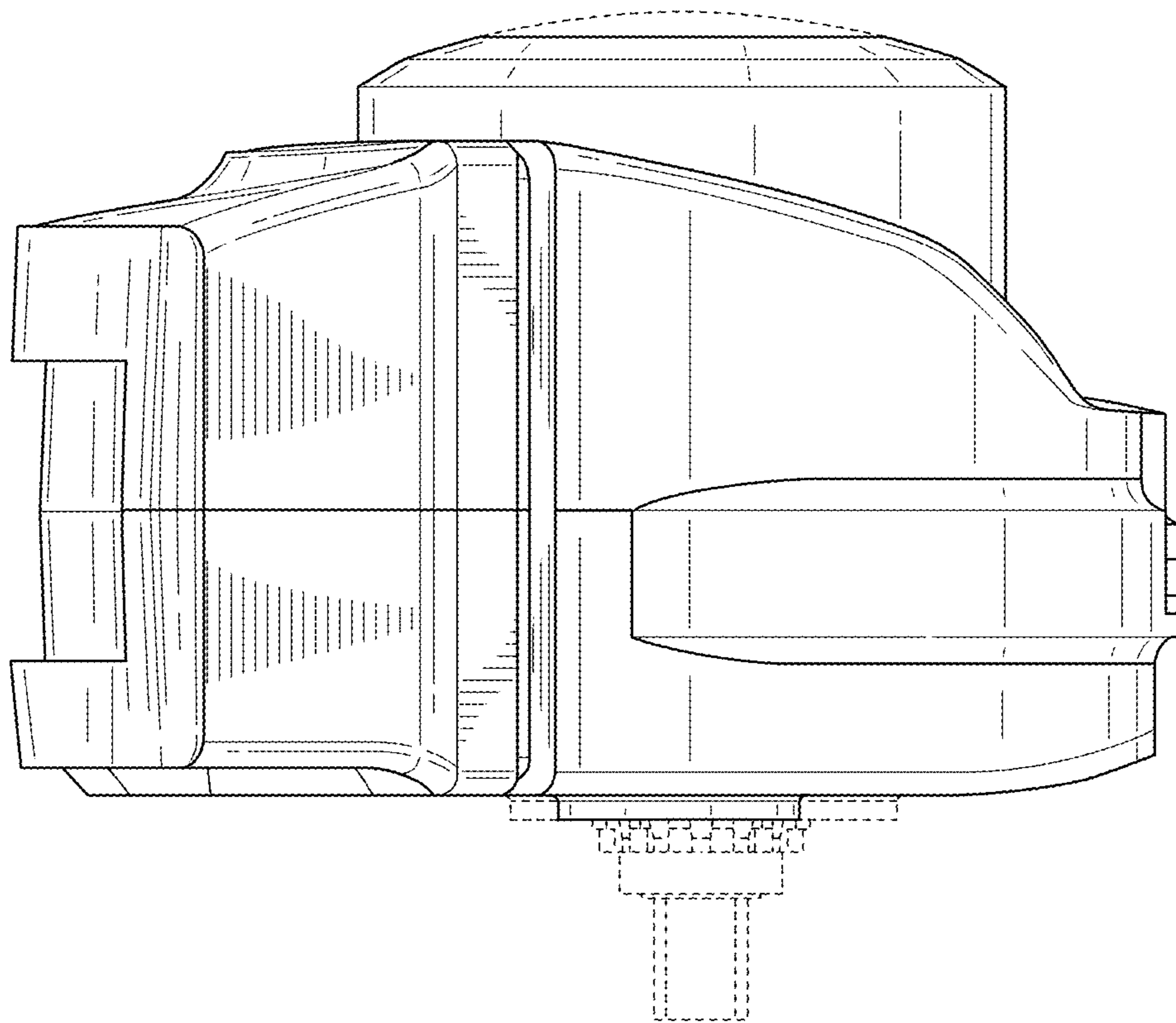

FIG. 2

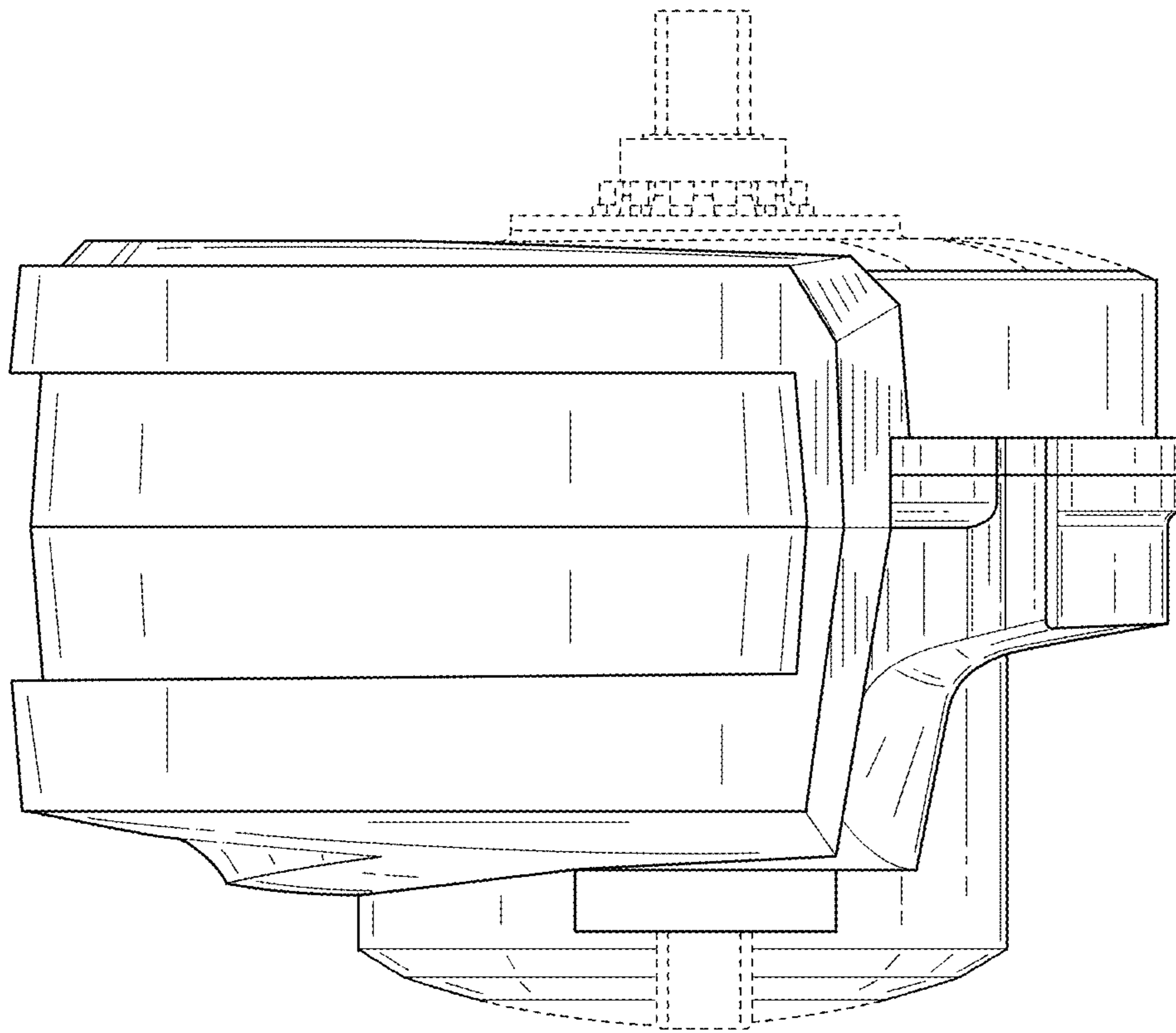

FIG. 3

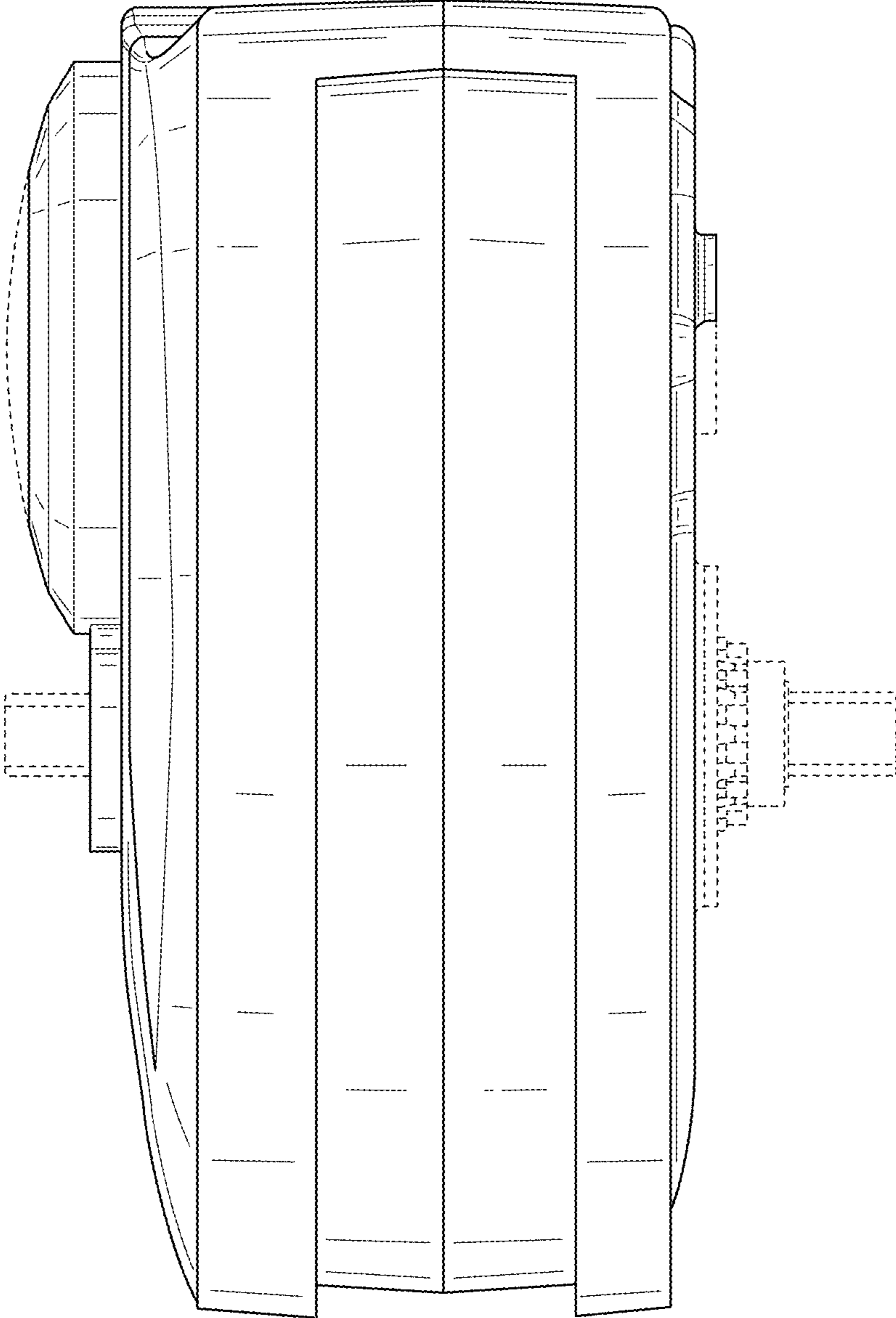

FIG. 4

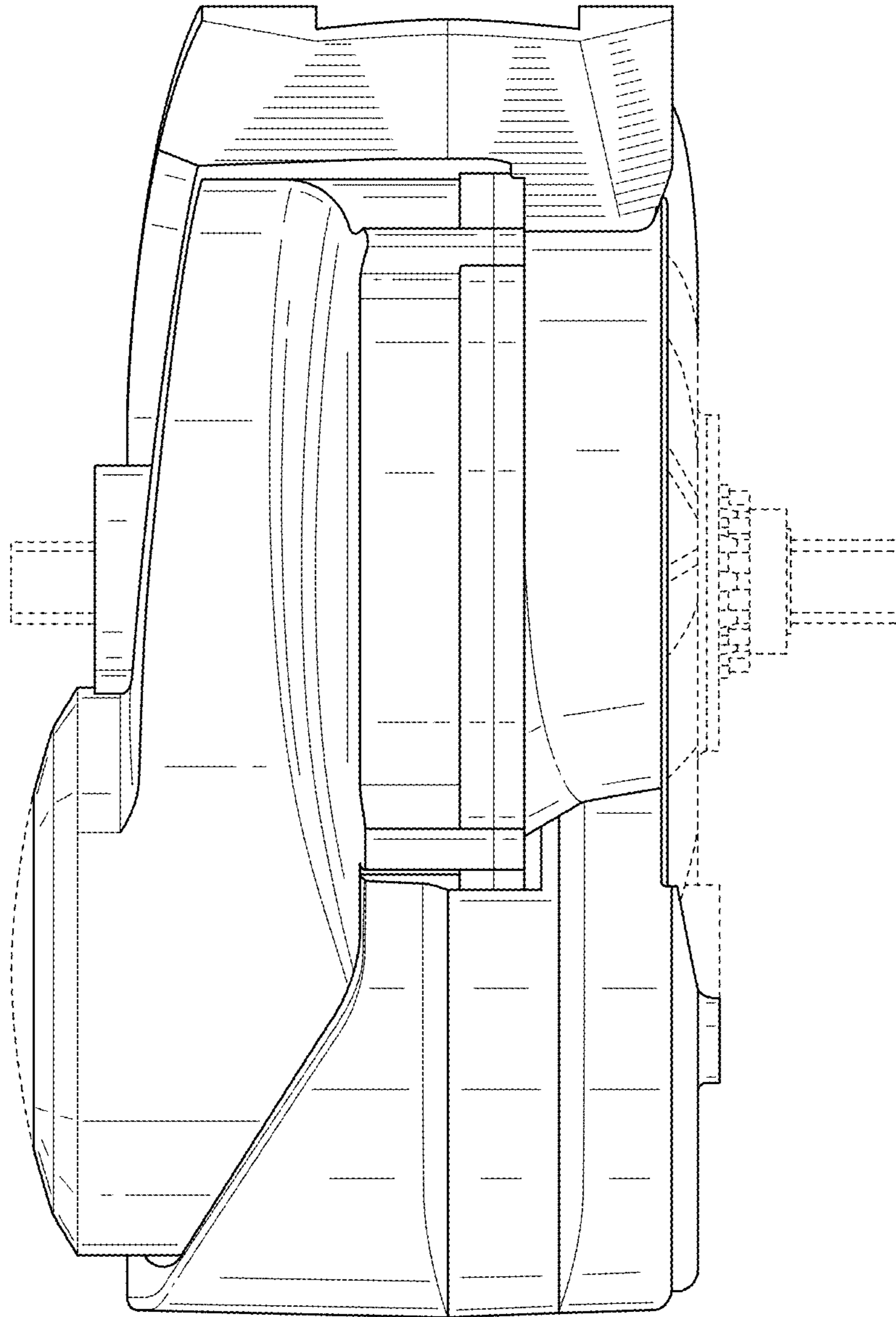

FIG. 5

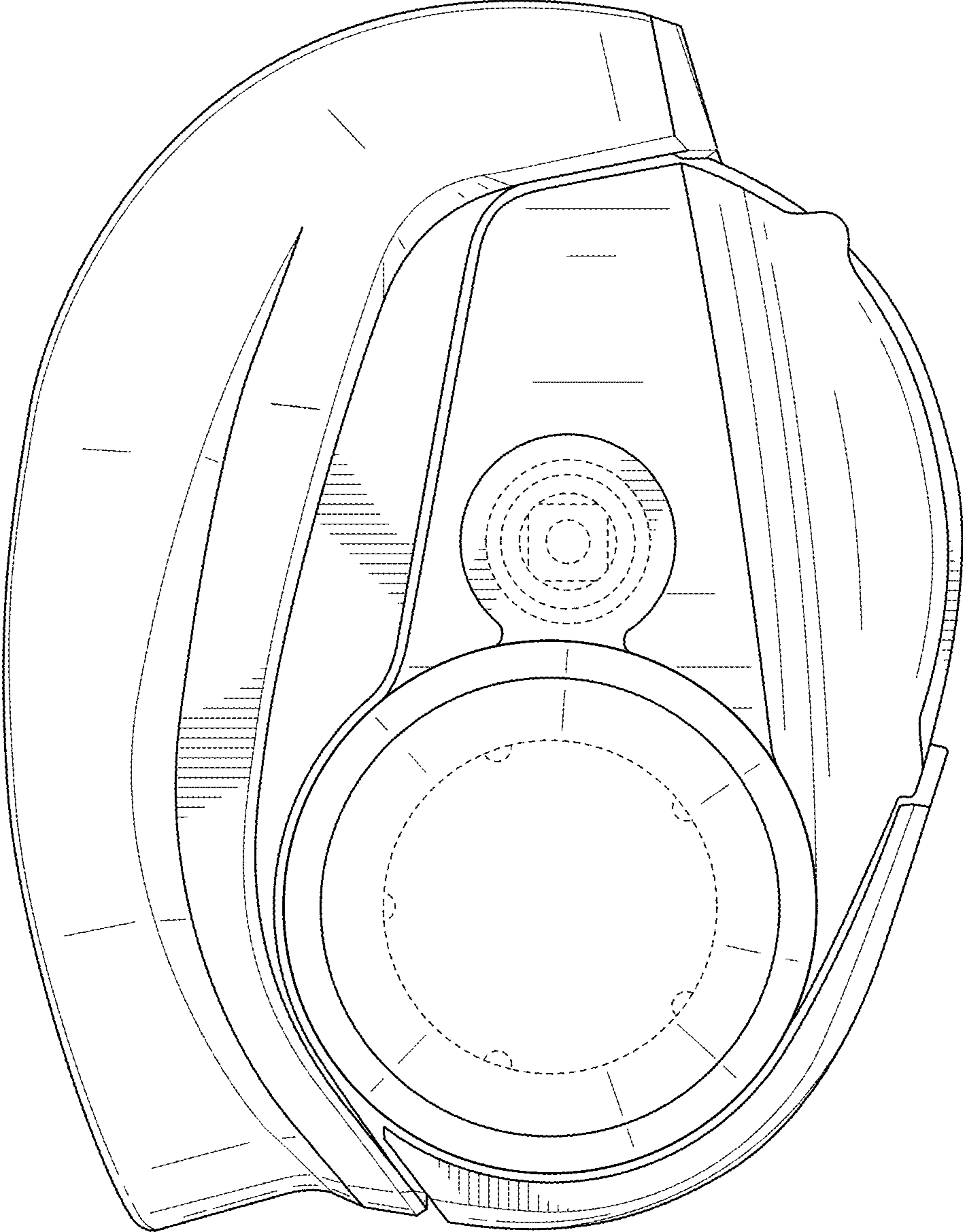

FIG. 6

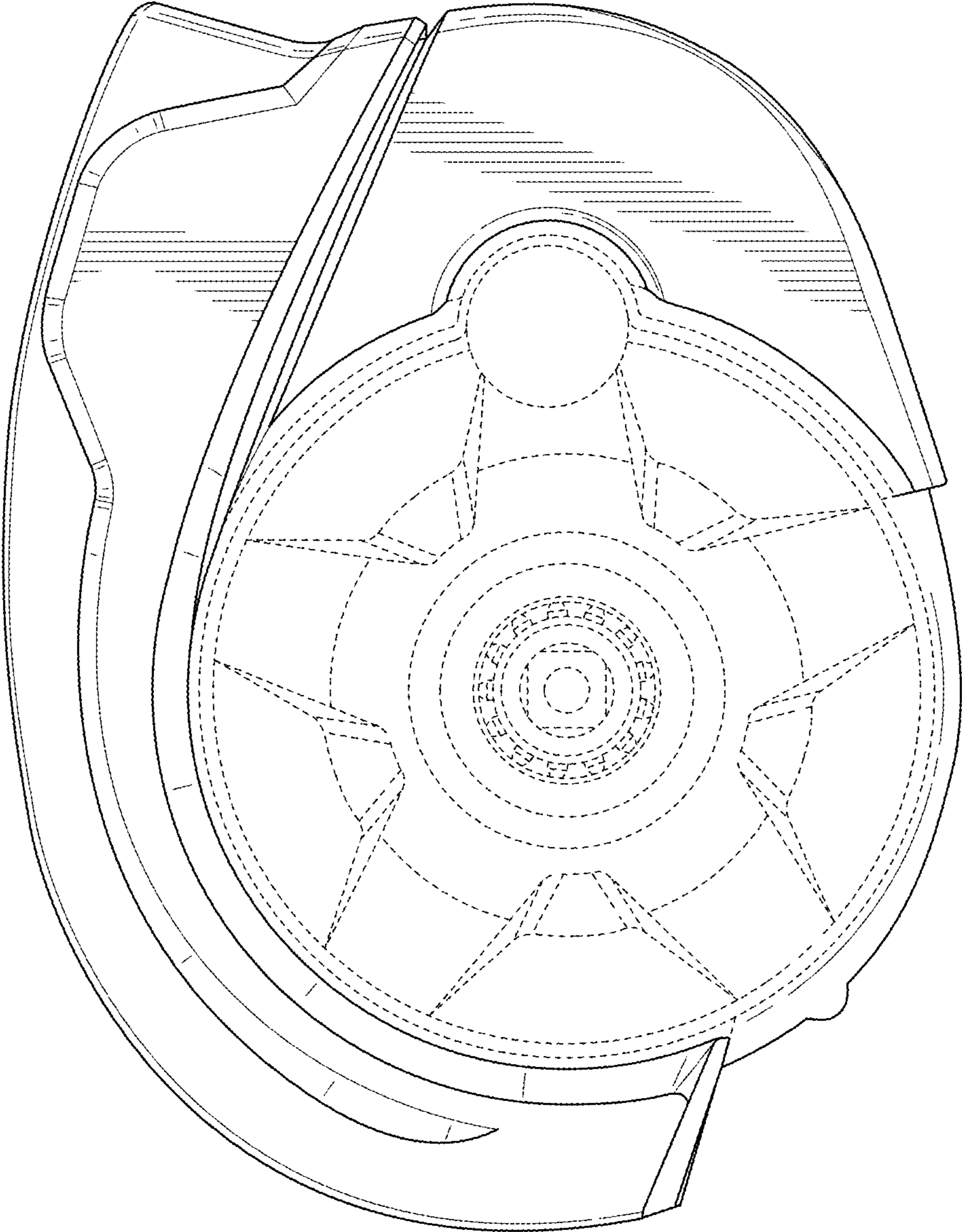

FIG. 7