



US00D800914S

(12) **United States Design Patent** (10) **Patent No.:** **US D800,914 S**
Kelly (45) **Date of Patent:** **** Oct. 24, 2017**

(54) **STATUS INDICATOR FOR MOLECULAR DIAGNOSTIC DEVICE**

(71) Applicant: **Click Diagnostics, Inc.**, Menlo Park, CA (US)

(72) Inventor: **Colin Kelly**, San Francisco, CA (US)

(73) Assignee: **Click Diagnostics, Inc.**, San Jose, CA (US)

(**) Term: **15 Years**

(21) Appl. No.: **29/569,828**

(22) Filed: **Jun. 30, 2016**

(51) **LOC (10) Cl.** **24-01**

(52) **U.S. Cl.**
USPC **D24/216**

(58) **Field of Classification Search**
USPC D24/216, 107, 169, 186, 217-219, 231, D24/232, 233; D10/81

(Continued)

(56) **References Cited**

U.S. PATENT DOCUMENTS

3,697,227 A 10/1972 Goldstein et al.
4,710,355 A 12/1987 Ushikubo

(Continued)

FOREIGN PATENT DOCUMENTS

WO WO01/49416 A1 7/2001
WO WO2009/047804 A2 4/2009

(Continued)

OTHER PUBLICATIONS

Kopp et al., "Chemical Amplification: Continuous-Flow PCR on a Chip", *Science* (1998); 280 (5366): 1046-1048.

(Continued)

Primary Examiner — Wan Laymon

Assistant Examiner — Mark Booker

(74) *Attorney, Agent, or Firm* — ReavesColey PLLC

(57) **CLAIM**

The ornamental design for a status indicator for a molecular diagnostic device, as shown and described.

DESCRIPTION

FIG. 1 is a top perspective view of the status indicator for molecular diagnostic device;

FIG. 2 is a bottom perspective view of the status indicator for molecular diagnostic device illustrated in FIG. 1;

FIG. 3 is a top view of the status indicator for molecular diagnostic device illustrated in FIG. 1;

FIG. 4 is a bottom view of the status indicator for molecular diagnostic device illustrated in FIG. 1;

FIG. 5 is a left side view of the status indicator for molecular diagnostic device illustrated in FIG. 1;

FIG. 6 is a right side view of the status indicator for molecular diagnostic device illustrated in FIG. 1;

FIG. 7 is a rear view of the status indicator for molecular diagnostic device illustrated in FIG. 1;

FIG. 8 is a front view of the detection window for status indicator for molecular diagnostic device illustrated in FIG. 1;

FIG. 9 is a top perspective view of the status indicator for molecular diagnostic device in FIG. 1, including a region 10; and,

FIG. 10 is an enlarged top perspective view of the status indicator for molecular diagnostic device illustrated in FIG. 1, the enlarged region being identified by the region 10 in FIG. 9, and showing three status indicators of the status indicator for molecular diagnostic device.

In the drawings, the dashed lines (- -) depict portions of the article that form no part of the claimed design. The chain lines (- - -) represent the bounds of the claimed design. The boundary illustrated by the chain lines does not exist in reality in the article embodying the design.

1 Claim, 10 Drawing Sheets

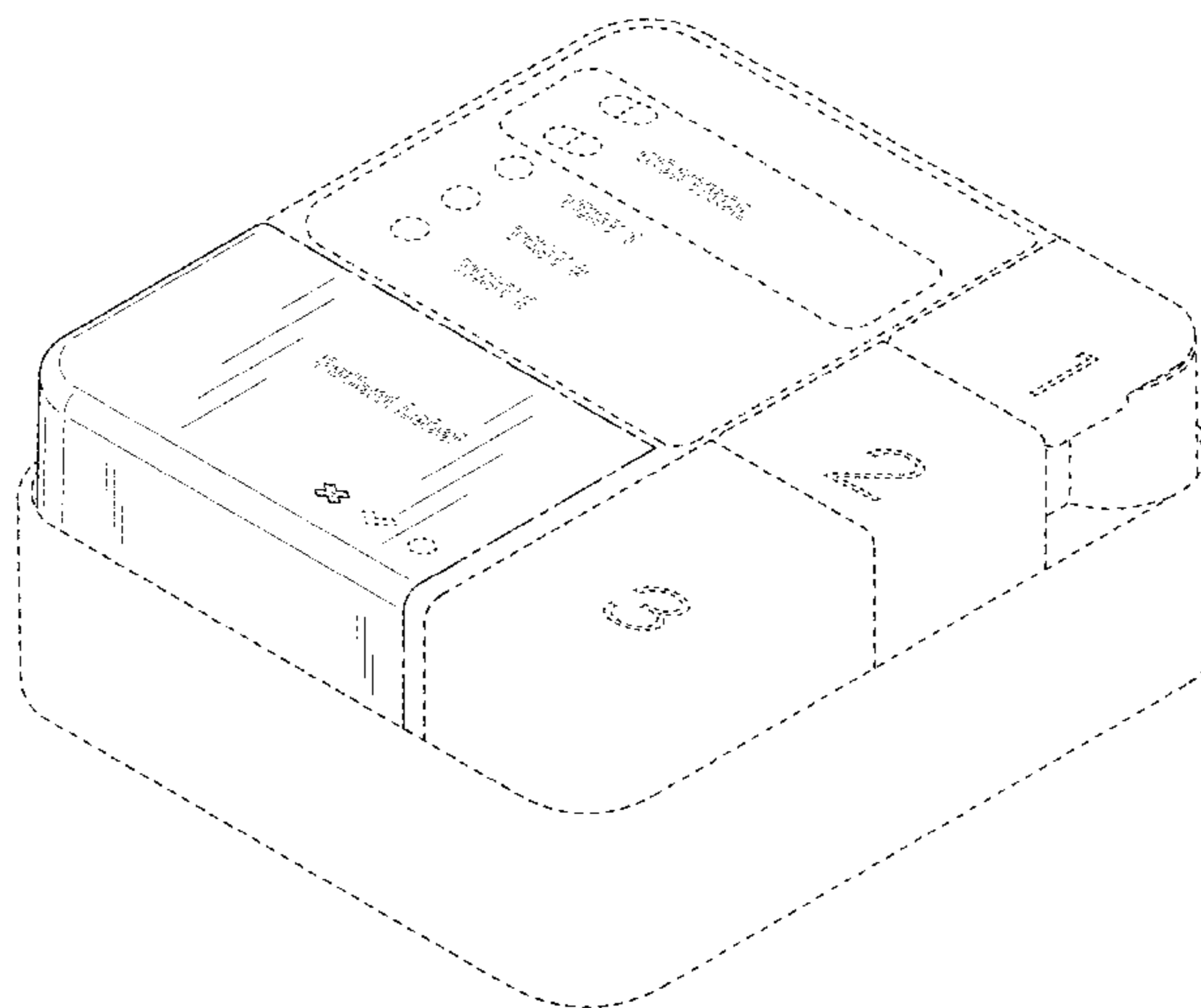

(58) **Field of Classification Search**
 CPC G01N 2035/00306; G01N 2035/00326;
 G01N 2035/00336; G01N 33/53; G01N
 33/5302; G01N 33/569; C12Q 1/686;
 B01L 7/52
 See application file for complete search history.

(56) **References Cited**

U.S. PATENT DOCUMENTS

| | | | | | |
|--------------|---------|----------------------|--------------|---------|-------------------|
| 4,889,692 A | 12/1989 | Holtzman | 7,709,250 B2 | 5/2010 | Corbett et al. |
| RE33,858 E | 3/1992 | Gropper et al. | 7,754,452 B2 | 7/2010 | Kim et al. |
| 5,164,159 A | 11/1992 | Hayashi et al. | 7,767,439 B2 | 8/2010 | Oh et al. |
| 5,229,297 A | 7/1993 | Schnipelsky et al. | 7,794,656 B2 | 9/2010 | Liang et al. |
| 5,273,905 A | 12/1993 | Muller et al. | 7,837,939 B2 | 11/2010 | Tung et al. |
| 5,405,585 A | 4/1995 | Coassin | 7,858,396 B2 | 12/2010 | Corstjens et al. |
| 5,429,807 A | 7/1995 | Matson et al. | 7,871,568 B2 | 1/2011 | Liang et al. |
| 5,631,165 A | 5/1997 | Chupp et al. | 7,879,293 B2 | 2/2011 | Niedbala et al. |
| 5,633,168 A | 5/1997 | Glasscock et al. | 7,914,986 B2 | 3/2011 | Nunn |
| 5,660,993 A | 8/1997 | Cathey et al. | 7,915,013 B2 | 3/2011 | Cho et al. |
| 5,773,234 A | 6/1998 | Pronovost et al. | 7,943,348 B2 | 5/2011 | Cho et al. |
| 5,882,903 A | 3/1999 | Andrevski et al. | 7,959,877 B2 | 6/2011 | Esfandiari |
| 5,922,591 A | 7/1999 | Anderson et al. | 7,985,716 B2 | 7/2011 | Yershov et al. |
| 5,976,470 A | 11/1999 | Maiefski et al. | 7,988,915 B2 | 8/2011 | Lee et al. |
| 6,039,924 A | 3/2000 | Horn | 7,998,757 B2 | 8/2011 | Darrigrand et al. |
| 6,126,804 A | 10/2000 | Andresen | 8,008,046 B2 | 8/2011 | Maltezos et al. |
| 6,146,591 A | 11/2000 | Miller | 8,008,080 B2 | 8/2011 | Tokhtuev et al. |
| 6,153,425 A | 11/2000 | Kozwich et al. | 8,012,427 B2 | 9/2011 | Bommarito et al. |
| 6,168,760 B1 | 1/2001 | Horn | 8,018,593 B2 | 9/2011 | Tan et al. |
| 6,261,431 B1 | 7/2001 | Mathies et al. | 8,048,386 B2 | 11/2011 | Dority et al. |
| 6,303,081 B1 | 10/2001 | Mink et al. | 8,062,883 B2 | 11/2011 | Woudenberg et al. |
| 6,313,471 B1 | 11/2001 | Giebeler et al. | 8,075,854 B2 | 12/2011 | Yang et al. |
| 6,365,378 B1 | 4/2002 | Hirota et al. | 8,076,129 B2 | 12/2011 | Hanafusa et al. |
| 6,374,684 B1 | 4/2002 | Dority | 8,088,616 B2 | 1/2012 | Handique |
| 6,416,718 B1 | 7/2002 | Maiefski et al. | 8,110,148 B2 | 2/2012 | Ball et al. |
| 6,426,215 B1 | 7/2002 | Sandell | 8,133,671 B2 | 3/2012 | Williams et al. |
| 6,514,750 B2 | 2/2003 | Bordenkircher et al. | 8,133,703 B2 | 3/2012 | Ching et al. |
| 6,610,499 B1 | 8/2003 | Fulwyler et al. | 8,163,535 B2 | 4/2012 | Reed et al. |
| 6,649,378 B1 | 11/2003 | Kozwich et al. | 8,169,610 B2 | 5/2012 | Oldham et al. |
| 6,656,744 B2 | 12/2003 | Pronovost et al. | 8,173,077 B2 | 5/2012 | Korampally et al. |
| 6,677,151 B2 | 1/2004 | Sandell | 8,187,557 B2 | 5/2012 | Van Atta et al. |
| 6,780,380 B2 | 8/2004 | Hunnell et al. | 8,198,074 B2 | 6/2012 | Moriwaki et al. |
| 6,780,617 B2 | 8/2004 | Chen | 8,216,832 B2 | 7/2012 | Battrell et al. |
| 6,781,056 B1 | 8/2004 | O'Rourke et al. | 8,231,844 B2 | 7/2012 | Gorfinkel |
| 6,813,568 B2 | 11/2004 | Powell et al. | 8,232,091 B2 | 7/2012 | Maltezos et al. |
| 6,821,771 B2 | 11/2004 | Festoc | 8,232,094 B2 | 7/2012 | Hasson et al. |
| 6,875,403 B2 | 4/2005 | Liu et al. | 8,247,221 B2 | 8/2012 | Fawcett |
| 6,893,879 B2 | 5/2005 | Petersen et al. | 8,263,392 B2 | 9/2012 | Gale et al. |
| 6,901,217 B2 | 5/2005 | Gamboa et al. | 8,277,763 B2 | 10/2012 | Steinmann et al. |
| 6,911,181 B1 | 6/2005 | McNeil | 8,278,091 B2 | 10/2012 | Rutter et al. |
| 6,990,290 B2 | 1/2006 | Kylberg et al. | 8,298,763 B2 | 10/2012 | Regan |
| 7,041,481 B2 | 5/2006 | Anderson et al. | 8,323,583 B2 | 12/2012 | Gou et al. |
| 7,144,742 B2 | 12/2006 | Boehringer et al. | 8,329,453 B2 | 12/2012 | Battrell et al. |
| 7,179,639 B2 | 2/2007 | Pottathil et al. | 8,343,442 B2 | 1/2013 | McBride et al. |
| 7,189,522 B2 | 3/2007 | Esfandiari | 8,357,490 B2 | 1/2013 | Froehlich et al. |
| 7,192,721 B1 | 3/2007 | Esfandiari | 8,372,340 B2 | 2/2013 | Bird et al. |
| 7,235,216 B2 | 6/2007 | Kiselev et al. | 8,389,960 B2 | 3/2013 | Pieprzyk et al. |
| 7,297,313 B1 | 11/2007 | Northrup et al. | 8,394,322 B2 | 3/2013 | Windeyer et al. |
| 7,341,697 B2 | 3/2008 | Takeuchi et al. | 8,394,608 B2 | 3/2013 | Ririe et al. |
| 7,377,291 B2 | 5/2008 | Moon et al. | 8,394,626 B2 | 3/2013 | Ramsey et al. |
| 7,378,285 B2 | 5/2008 | Lambotte et al. | 8,431,413 B2 | 4/2013 | Dority et al. |
| 7,384,782 B2 | 6/2008 | Nakatani et al. | 8,435,461 B2 | 5/2013 | Kirby et al. |
| 7,438,852 B2 | 10/2008 | Tung et al. | 8,448,824 B2 | 5/2013 | DiPerna |
| 7,459,302 B2 | 12/2008 | Reid et al. | 8,492,136 B2 | 7/2013 | Carlisle et al. |
| 7,491,551 B2 | 2/2009 | Boehringer et al. | 8,507,259 B2 | 8/2013 | Esfandiari |
| 7,517,495 B2 | 4/2009 | Wu et al. | 8,580,575 B2 | 11/2013 | Hanafusa |
| 7,544,324 B2 | 6/2009 | Tung et al. | 8,597,937 B2 | 12/2013 | Ward et al. |
| 7,550,112 B2 | 6/2009 | Gou et al. | 8,603,835 B2 | 12/2013 | Esfandiari |
| 7,553,675 B2 | 6/2009 | Jerome et al. | 8,617,486 B2 | 12/2013 | Kirby et al. |
| 7,569,382 B2 | 8/2009 | Li | 8,629,264 B2 | 1/2014 | Reed et al. |
| 7,579,172 B2 | 8/2009 | Cho et al. | 8,637,250 B2 | 1/2014 | Jenison |
| 7,592,139 B2 | 9/2009 | West et al. | 8,663,976 B2 | 3/2014 | Chung et al. |
| 7,632,687 B2 | 12/2009 | Gokhan | 8,673,238 B2 | 3/2014 | Dority et al. |
| 7,648,835 B2 | 1/2010 | Breidford et al. | 8,673,239 B2 | 3/2014 | Niedbala et al. |
| 7,682,801 B2 | 3/2010 | Esfandiari | 8,691,561 B2 | 4/2014 | Igata |
| 7,691,644 B2 | 4/2010 | Lambotte et al. | 8,722,426 B2 | 5/2014 | Lambotte et al. |
| 7,705,339 B2 | 4/2010 | Smith et al. | 8,728,765 B2 | 5/2014 | Ching et al. |
| | | | 8,735,103 B2 | 5/2014 | Chung et al. |
| | | | 8,758,701 B2 | 6/2014 | Van Atta et al. |
| | | | 8,765,454 B2 | 7/2014 | Zhou et al. |
| | | | 8,772,017 B2 | 7/2014 | Battrell et al. |
| | | | 8,795,592 B2 | 8/2014 | Eiriksson |
| | | | 8,859,199 B2 | 10/2014 | Hellyer et al. |
| | | | 8,865,458 B2 | 10/2014 | Ramsey et al. |
| | | | 8,871,155 B2 | 10/2014 | Wu et al. |
| | | | D717,459 S * | 11/2014 | Lin D24/216 |
| | | | 8,877,450 B2 | 11/2014 | Esfandiari |
| | | | 8,894,946 B2 | 11/2014 | Nielsen et al. |
| | | | 8,900,828 B2 | 12/2014 | Smith et al. |

(56)

References Cited

U.S. PATENT DOCUMENTS

8,900,853 B2 12/2014 Verhaar et al.
 8,911,941 B2 12/2014 Michlitsch
 8,911,949 B2 12/2014 Bertrand et al.
 8,916,375 B2 12/2014 Landers et al.
 8,945,843 B2 2/2015 Alvino et al.
 8,975,027 B2 3/2015 Gale et al.
 8,980,177 B2 3/2015 Carlisle et al.
 8,986,927 B2 3/2015 Lee et al.
 8,992,854 B2 3/2015 Brewster et al.
 9,011,770 B2 4/2015 Wu et al.
 9,012,236 B2 4/2015 Jovanovich et al.
 9,023,639 B2 5/2015 Kim et al.
 9,044,729 B2 6/2015 Rengifo et al.
 D739,037 S * 9/2015 Lin D24/216
 9,207,241 B2 12/2015 Lambotte et al.
 D747,227 S * 1/2016 Fujiwara D10/81
 9,243,288 B2 1/2016 Ness et al.
 9,475,049 B2 10/2016 Siciliano et al.
 D774,205 S * 12/2016 Grace D24/169
 D776,290 S * 1/2017 Wan D24/169
 2001/0055799 A1 12/2001 Baunoch et al.
 2003/0027244 A1 2/2003 Colston et al.
 2004/0209331 A1 10/2004 Ririe
 2004/0224317 A1 11/2004 Kordunsky et al.
 2005/0227275 A1 10/2005 Jung et al.
 2007/0154922 A1 7/2007 Collier et al.
 2008/0026451 A1 1/2008 Braman et al.
 2008/0038737 A1 2/2008 Smith et al.
 2008/0050735 A1 2/2008 Pushnova
 2008/0153078 A1 6/2008 Braman et al.
 2008/0220468 A1 9/2008 Windeyer et al.
 2008/0280285 A1 11/2008 Chen et al.
 2009/0029422 A1 1/2009 Hanafusa et al.
 2009/0042256 A1 2/2009 Hanafusa et al.
 2009/0325276 A1 12/2009 Battrell et al.
 2010/0113762 A1 5/2010 Ball et al.
 2010/0173393 A1 7/2010 Handique et al.
 2010/0210038 A1 8/2010 Blatt et al.
 2010/0297640 A1 11/2010 Kumar et al.

2011/0211331 A1 9/2011 Alkjaer
 2011/0227551 A1 9/2011 Black
 2011/0269191 A1 11/2011 Belgrader et al.
 2011/0313148 A1 12/2011 Christ et al.
 2012/0021454 A1 1/2012 Bikker et al.
 2012/0135511 A1 5/2012 Battrell et al.
 2012/0141337 A1 6/2012 Maltezos et al.
 2012/0264202 A1 10/2012 Walker et al.
 2012/0288897 A1 11/2012 Ching et al.
 2013/0078736 A1 3/2013 Grover et al.
 2013/0115712 A1 5/2013 Yu et al.
 2013/0118900 A1 5/2013 Reimitz et al.
 2013/0171640 A1 7/2013 Kwon et al.
 2013/0210080 A1 8/2013 Rajagopal et al.
 2013/0220781 A1 8/2013 Czarnecki
 2014/0045191 A1 2/2014 DeJohn et al.
 2014/0051159 A1 2/2014 Bergstedt et al.
 2014/0098252 A1 4/2014 Chang et al.
 2014/0199685 A1 7/2014 Lambotte et al.
 2015/0031087 A1 1/2015 Nagai et al.
 2015/0176057 A1 6/2015 Smith et al.
 2015/0182966 A1 7/2015 Coursey et al.
 2016/0054316 A1 2/2016 Egan et al.
 2016/0310948 A1 10/2016 Nowakowski et al.

FOREIGN PATENT DOCUMENTS

WO WO2014/144548 A2 9/2014
 WO WO2015/138343 A1 9/2015
 WO WO2015/138648 A1 9/2015
 WO WO2015/164770 A1 10/2015
 WO WO2016/109691 A1 7/2016
 WO WO2016/203019 A1 12/2016

OTHER PUBLICATIONS

Tanriverdi et al. A rapid and automated sample-to-result HIV load test for near-patient application. J Infect Dis., 201 Suppl 1:S52-S58, 2010.

* cited by examiner

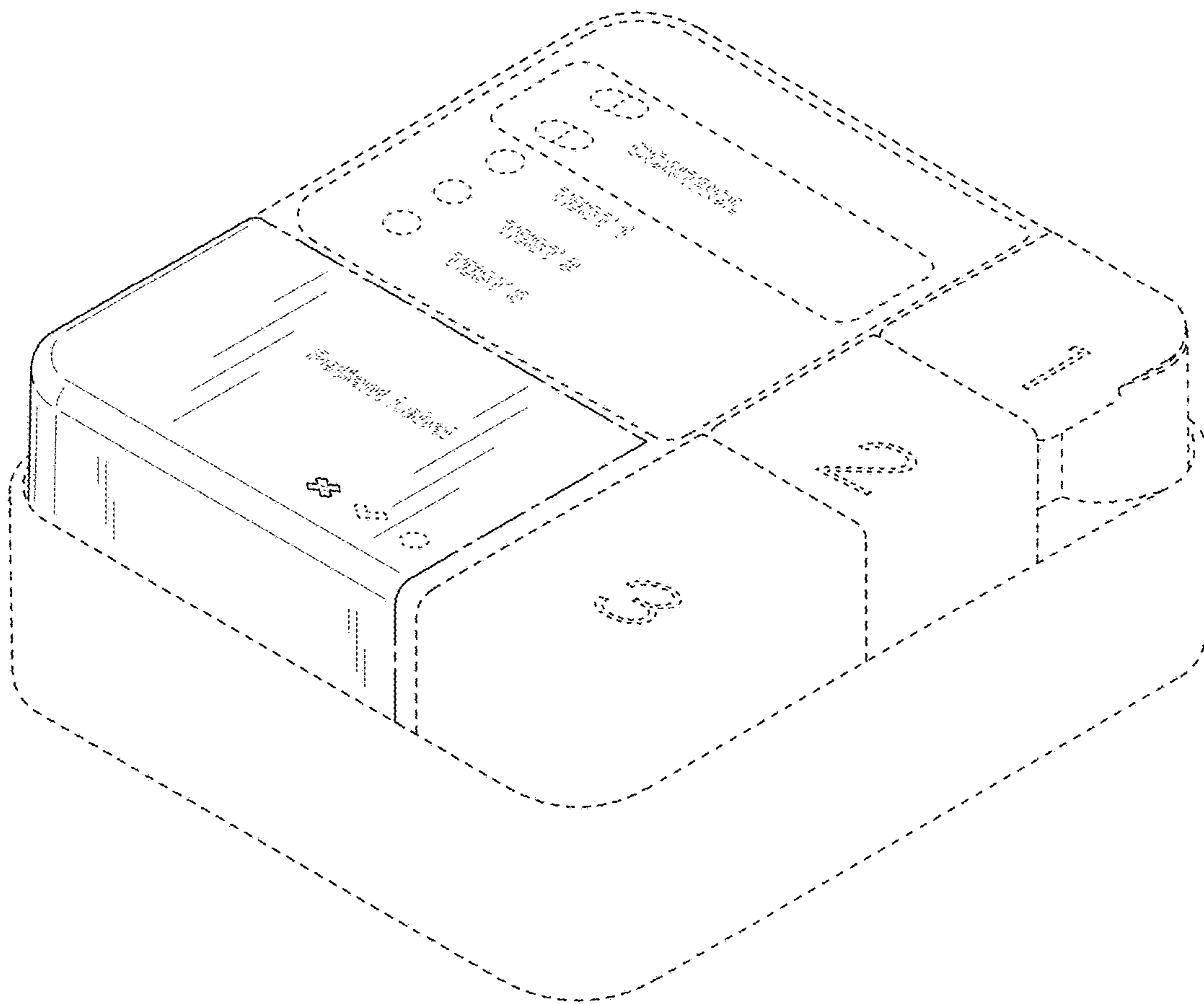

FIG. 1

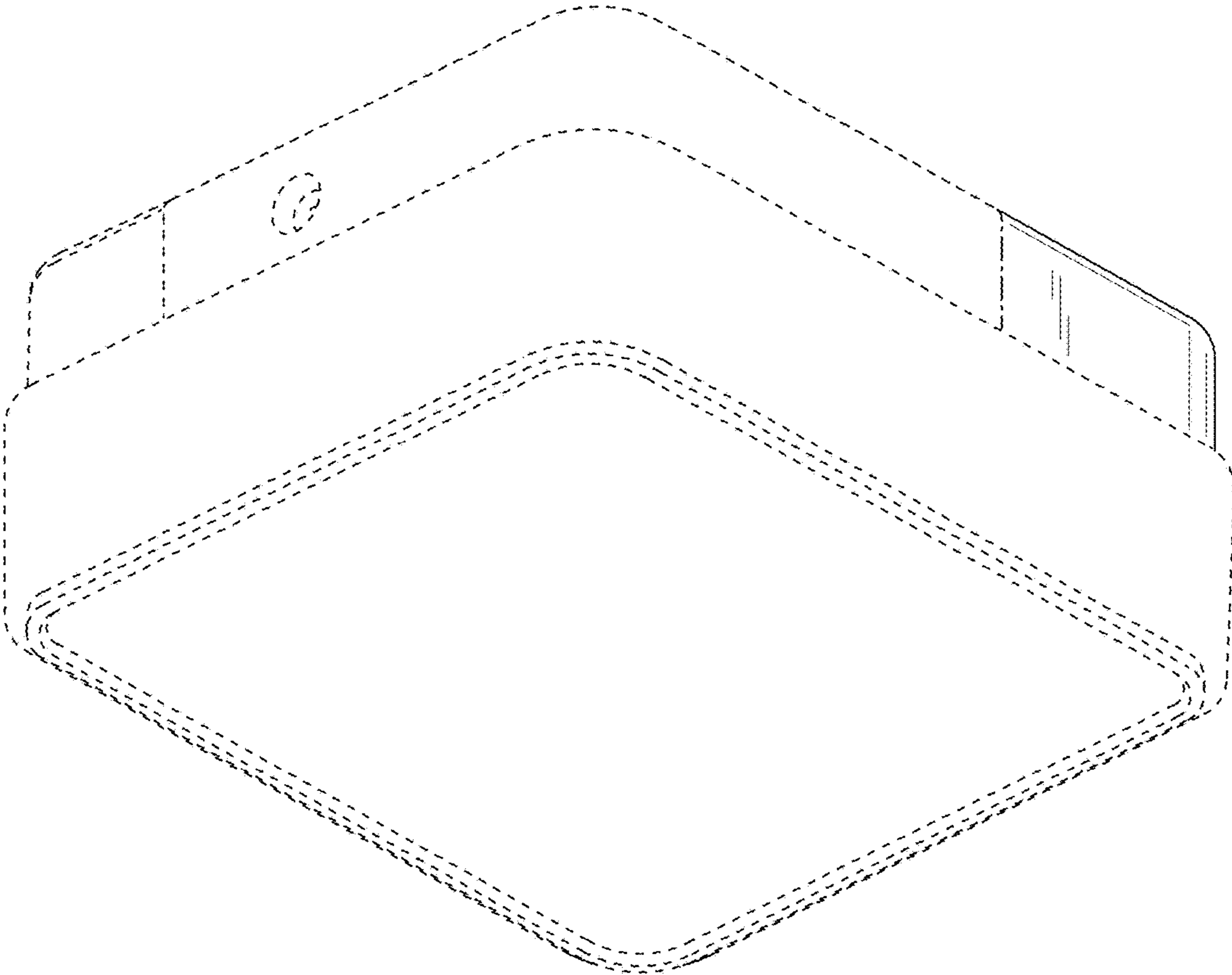

FIG. 2

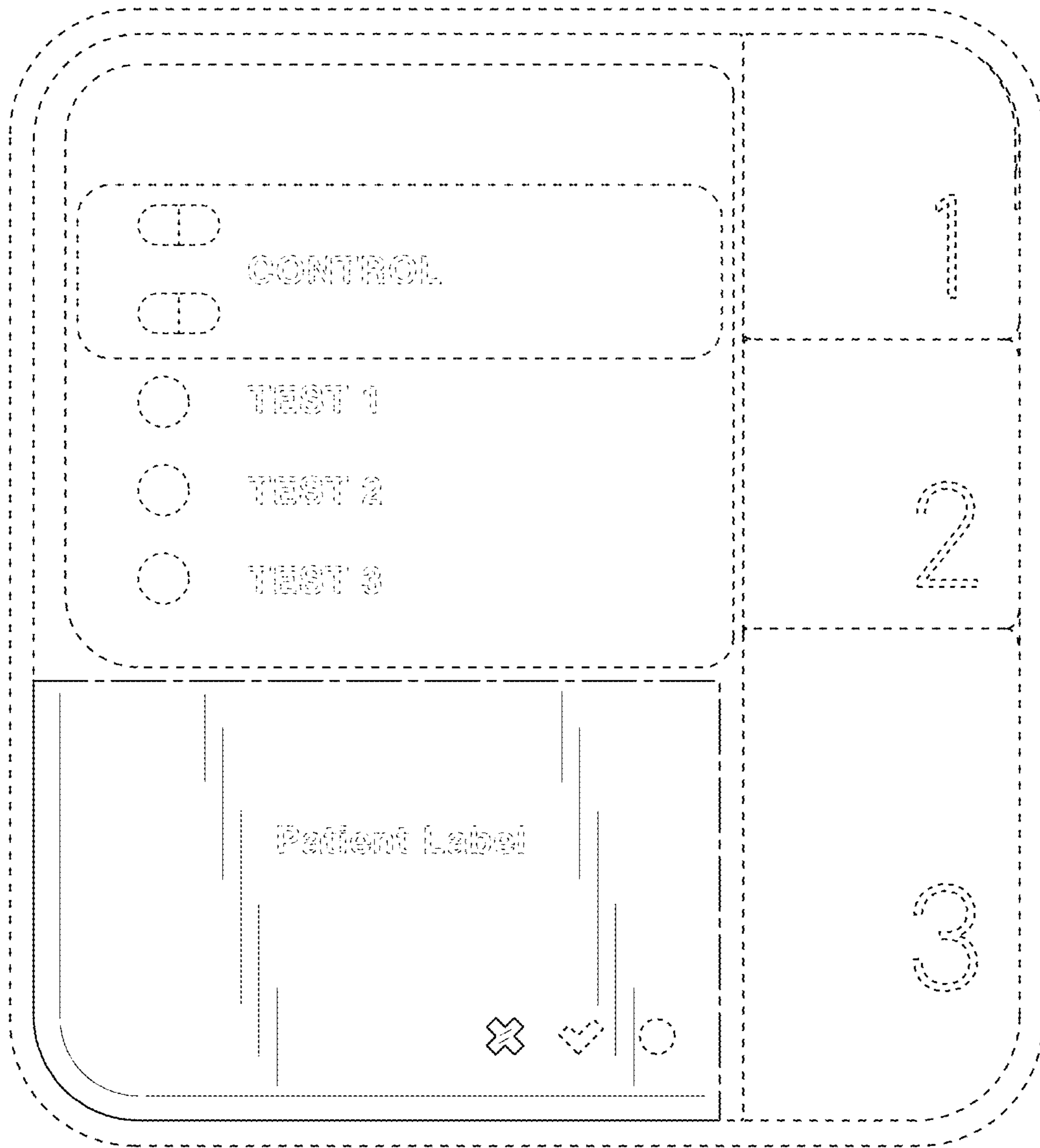

FIG. 3

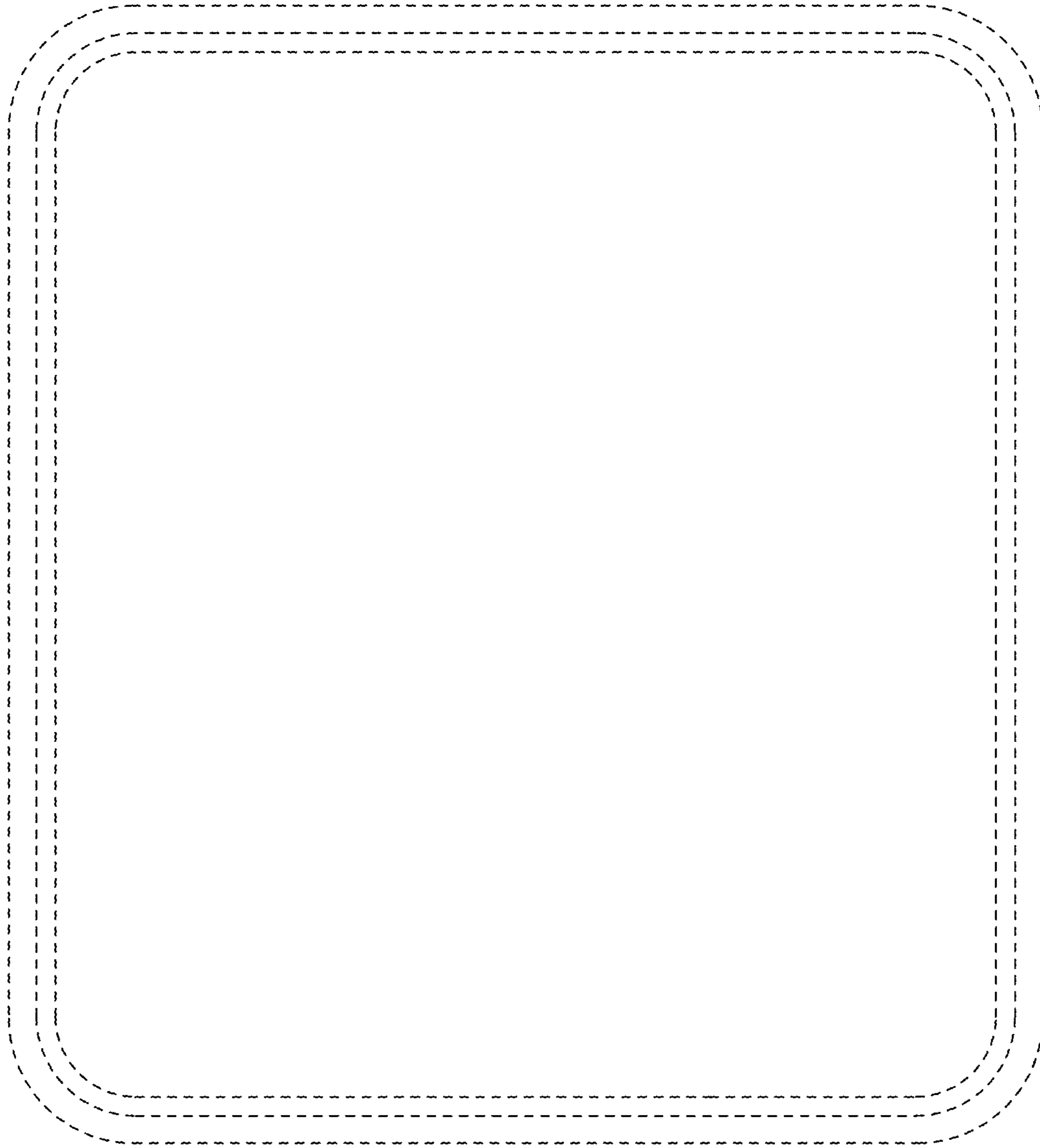

FIG. 4

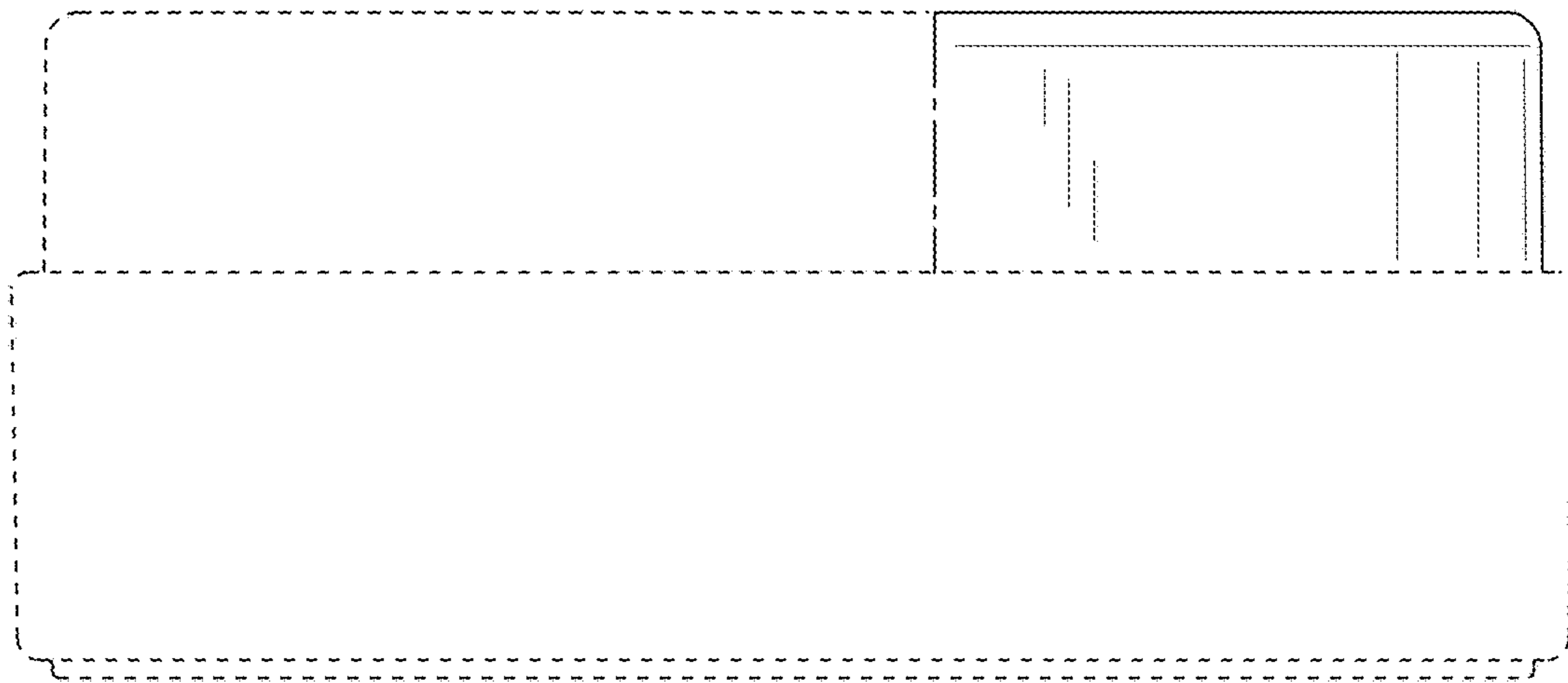

FIG. 5

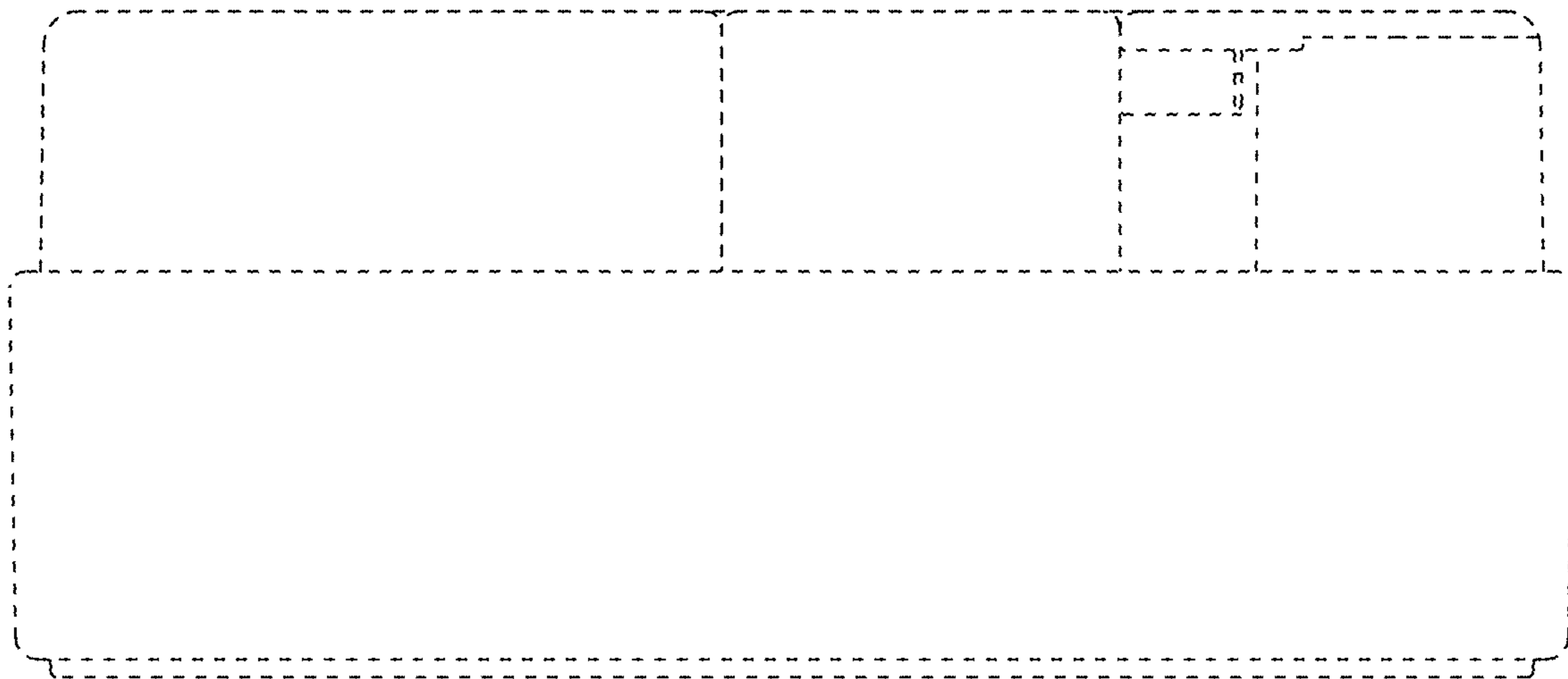

FIG. 6

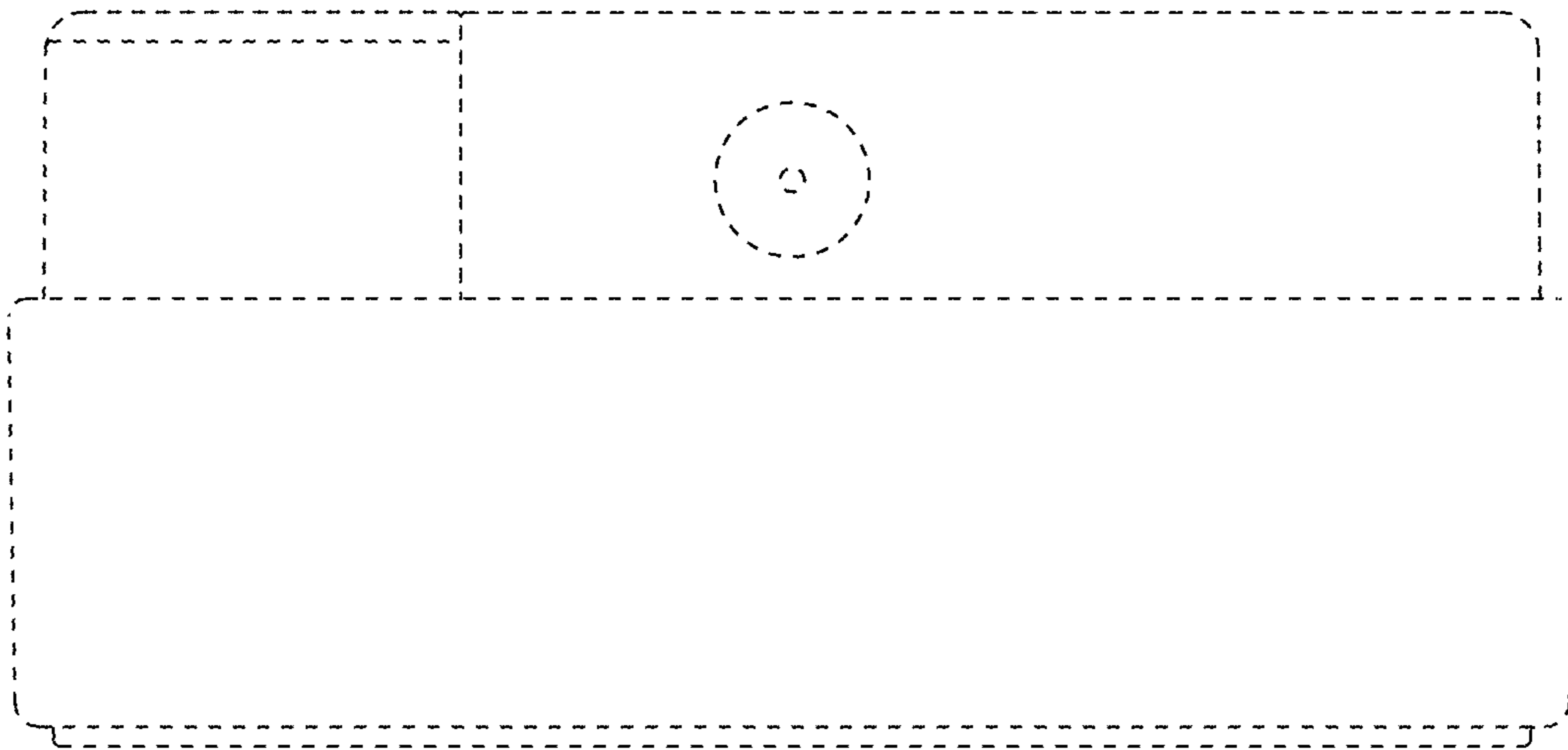

FIG. 7

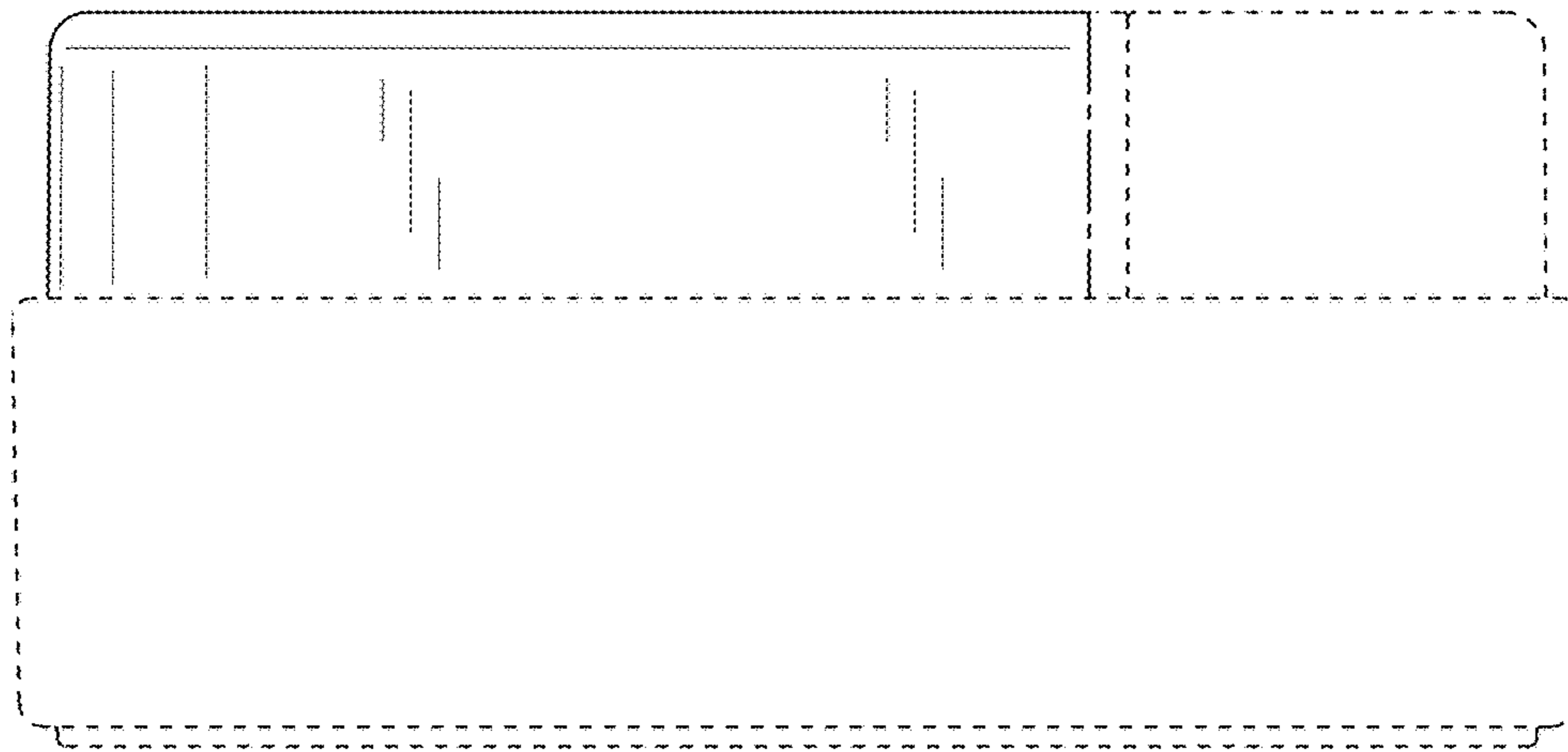

FIG. 8

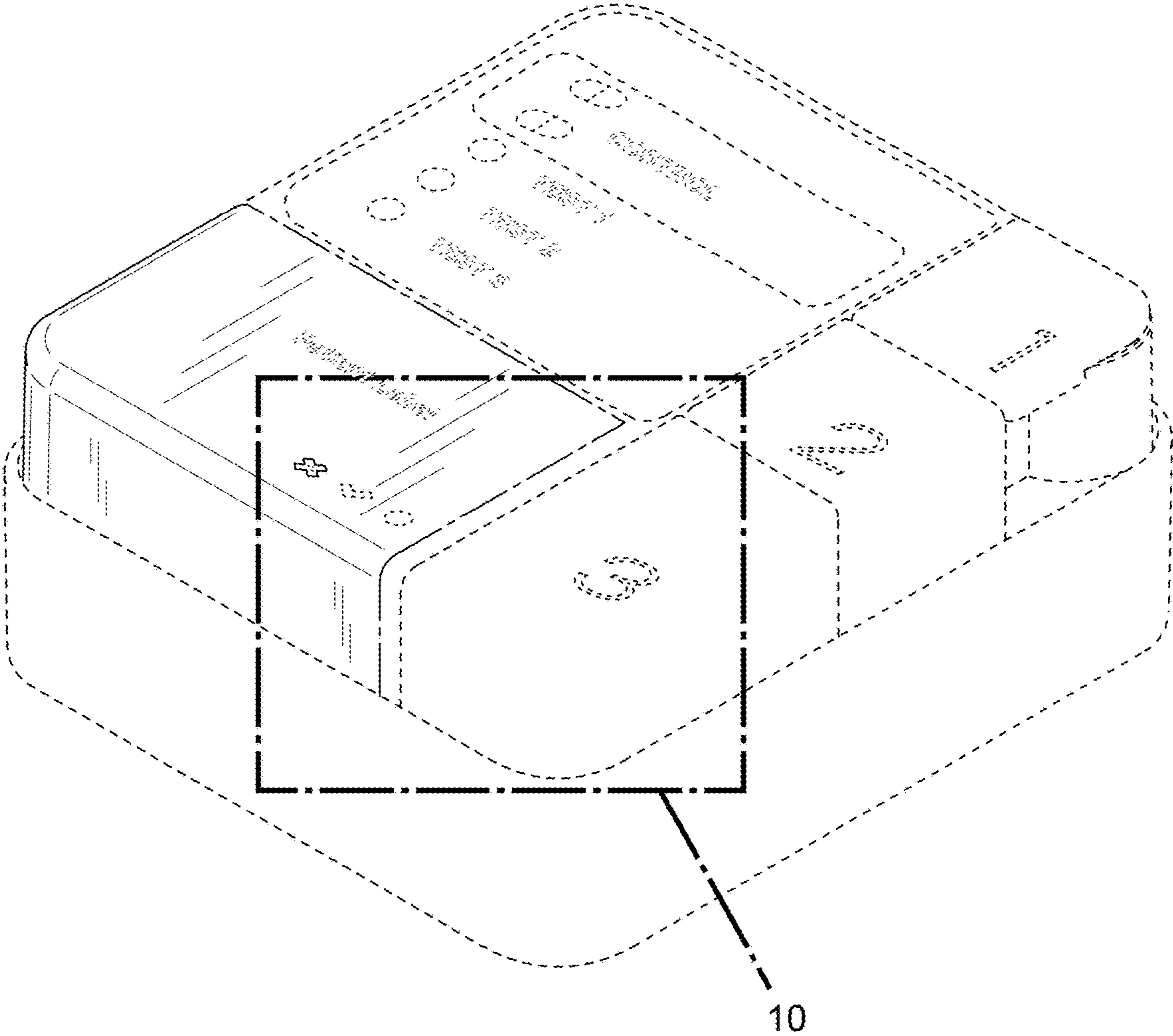

FIG. 9

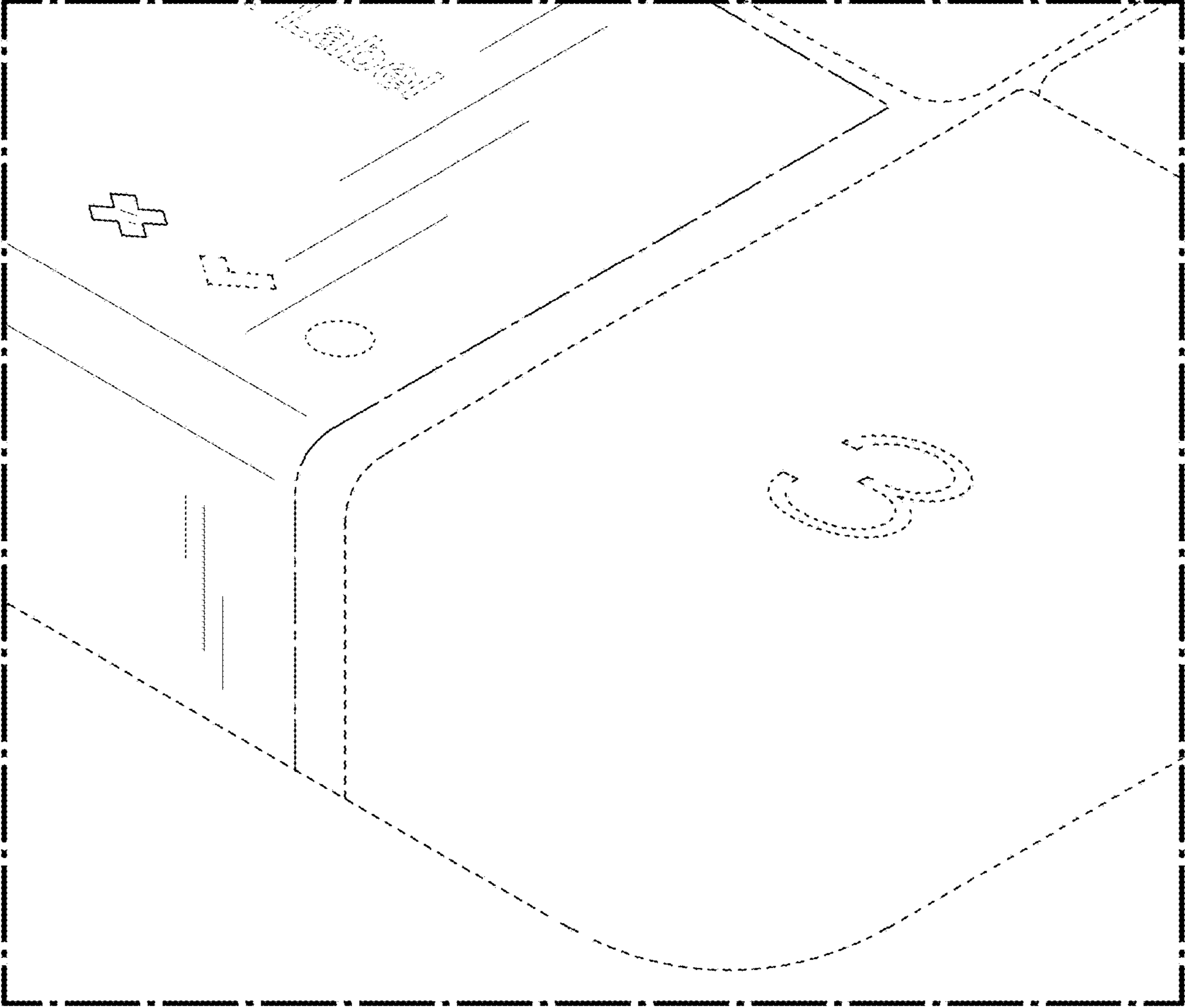

FIG. 10