



US00D800729S

(12) **United States Design Patent**
Nishizawa

(10) **Patent No.:** **US D800,729 S**
(45) **Date of Patent:** **** Oct. 24, 2017**

(54) **COORDINATE INPUT INSTRUMENT**

FOREIGN PATENT DOCUMENTS

(71) Applicant: **Wacom Co., Ltd.**, Kazo-shi, Saitama (JP)

JP H4-45784 U 4/1992
JP D1472422 S 6/2013

(Continued)

(72) Inventor: **Naoya Nishizawa**, Tokyo (JP)

(73) Assignee: **Wacom Co., Ltd.**, Kazo-shi (JP)

OTHER PUBLICATIONS

(**) Term: **15 Years**

“Adonit Jot Pro Stylus (Sliver),” Adonit, Mfg. No. ADJ3S, <http://www.bhphotovideo.com/c/product/1116533-REG/adonit_adj3s_jot_pro_stylus.html> [retrieved Jun. 30, 2016], 2 pages.

(21) Appl. No.: **29/558,868**

Primary Examiner — Austin Murphy

(22) Filed: **Mar. 22, 2016**

(74) *Attorney, Agent, or Firm* — Christensen O’Connor Johnson; Matthew Balint; Brandon Stallman

(30) **Foreign Application Priority Data**

Oct. 7, 2015 (JP) 2015-022063

(57) **CLAIM**

(51) **LOC (10) Cl.** **14-02**

The ornamental design for a coordinate input instrument, as shown and described.

(52) **U.S. Cl.**

USPC **D14/411**

DESCRIPTION

(58) **Field of Classification Search**

USPC D14/372, 496, 432, 371, 125, 126, 129, D14/299, 411; D16/300–342; 351/158, 351/153, 144; 345/7–9, 905; 455/344; 348/115, 53, 121, 739

CPC G02B 27/017; G06F 3/016; G06F 3/033; G06F 3/0317; G06F 3/03545; G06F 3/041; G06K 9/222

See application file for complete search history.

FIG. 1 is a front perspective view of a coordinate input instrument according to a representative embodiment of my new design;

FIG. 2 is a rear perspective view of the coordinate input instrument shown in FIG. 1;

FIG. 3 is a side view of the coordinate input instrument shown in FIG. 1, the side opposite of the side shown in FIG. 3 being a mirror image thereof and therefore not shown;

FIG. 4 is a front view of the coordinate input instrument shown in FIG. 1;

FIG. 5 is a rear view of the coordinate input instrument shown in FIG. 1;

FIG. 6 a top view of the coordinate input instrument shown in FIG. 1; and,

FIG. 7 is a bottom view of the coordinate input instrument shown in FIG. 1.

The broken lines show portions of the coordinate input instrument which form no part of the claimed design.

(56) **References Cited**

U.S. PATENT DOCUMENTS

D669,896 S * 10/2012 Nakata D14/411
D669,897 S * 10/2012 Nakata D14/411
D669,898 S * 10/2012 Nakata D14/411
D670,700 S * 11/2012 Halsinger D14/411
D682,833 S * 5/2013 Paschke D14/411
D717,301 S * 11/2014 Groene D14/411
D724,086 S * 3/2015 Schoenert D14/411
D727,325 S * 4/2015 Spector D14/411

(Continued)

1 Claim, 4 Drawing Sheets

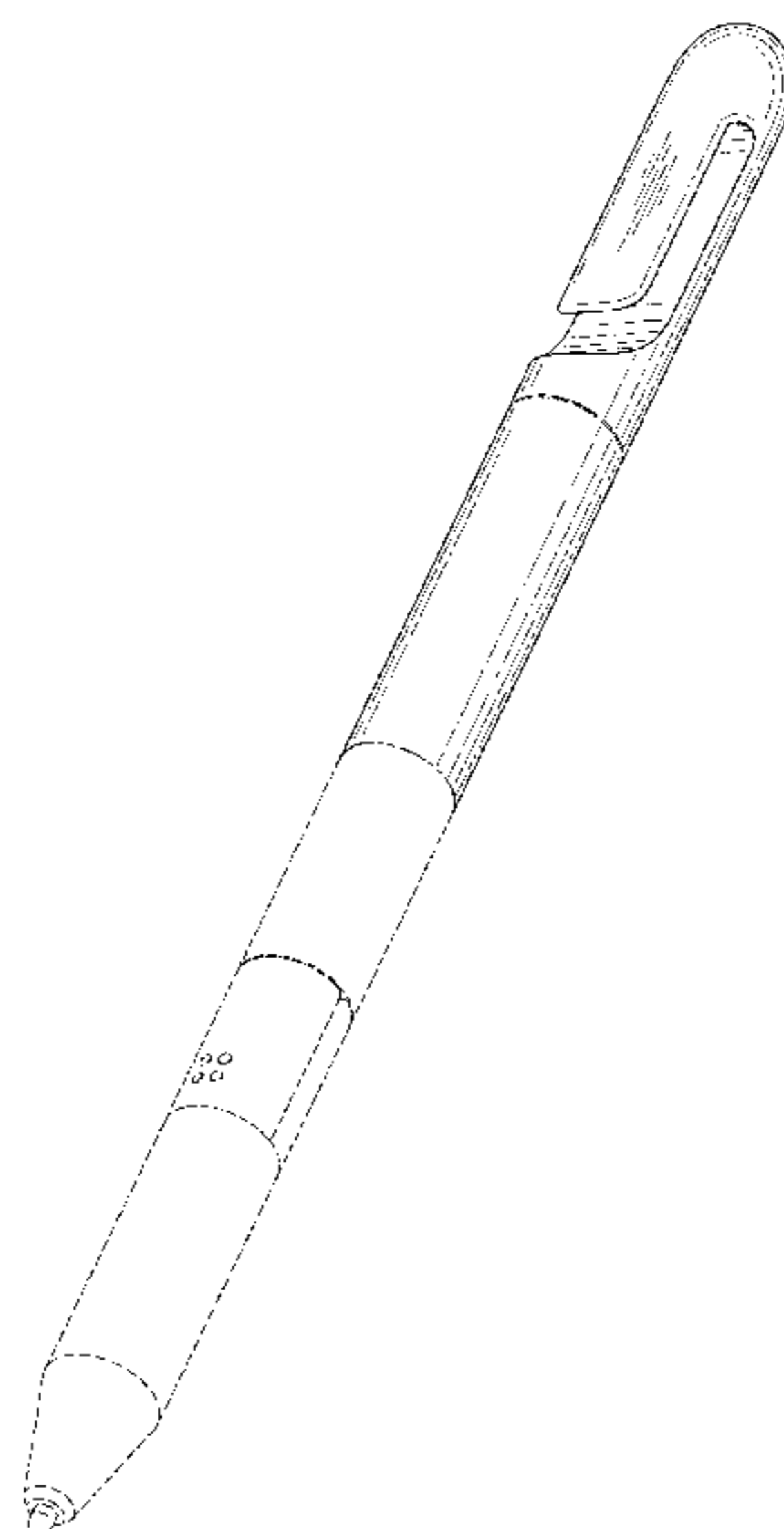

(56)

References Cited

U.S. PATENT DOCUMENTS

D772,230 S * 11/2016 Lee D14/411
D773,462 S * 12/2016 Mitchell D14/411

FOREIGN PATENT DOCUMENTS

KR 30-0683243 S 2/2013
KR 30-0805697 S 7/2015

* cited by examiner

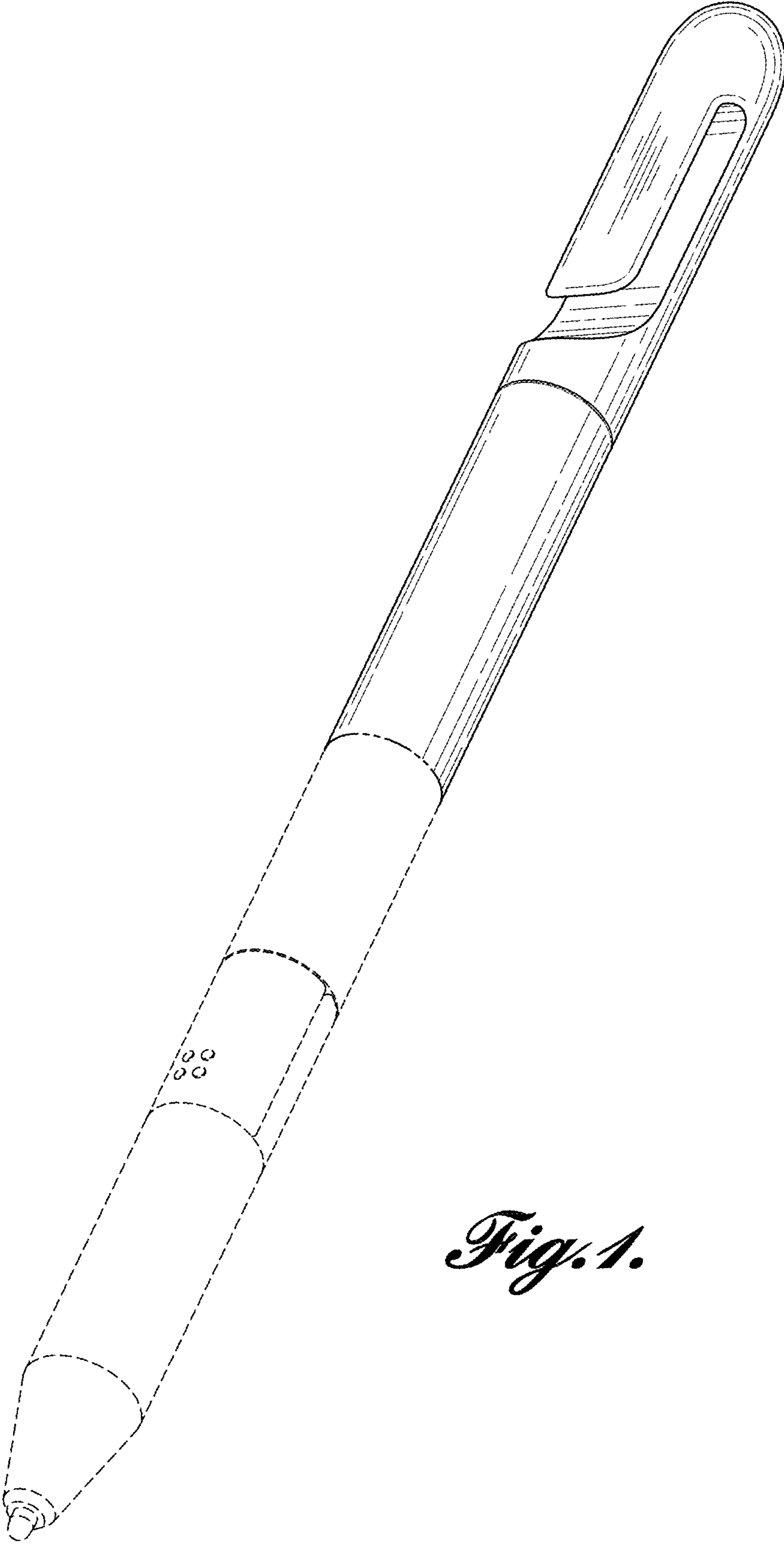

Fig. 1.

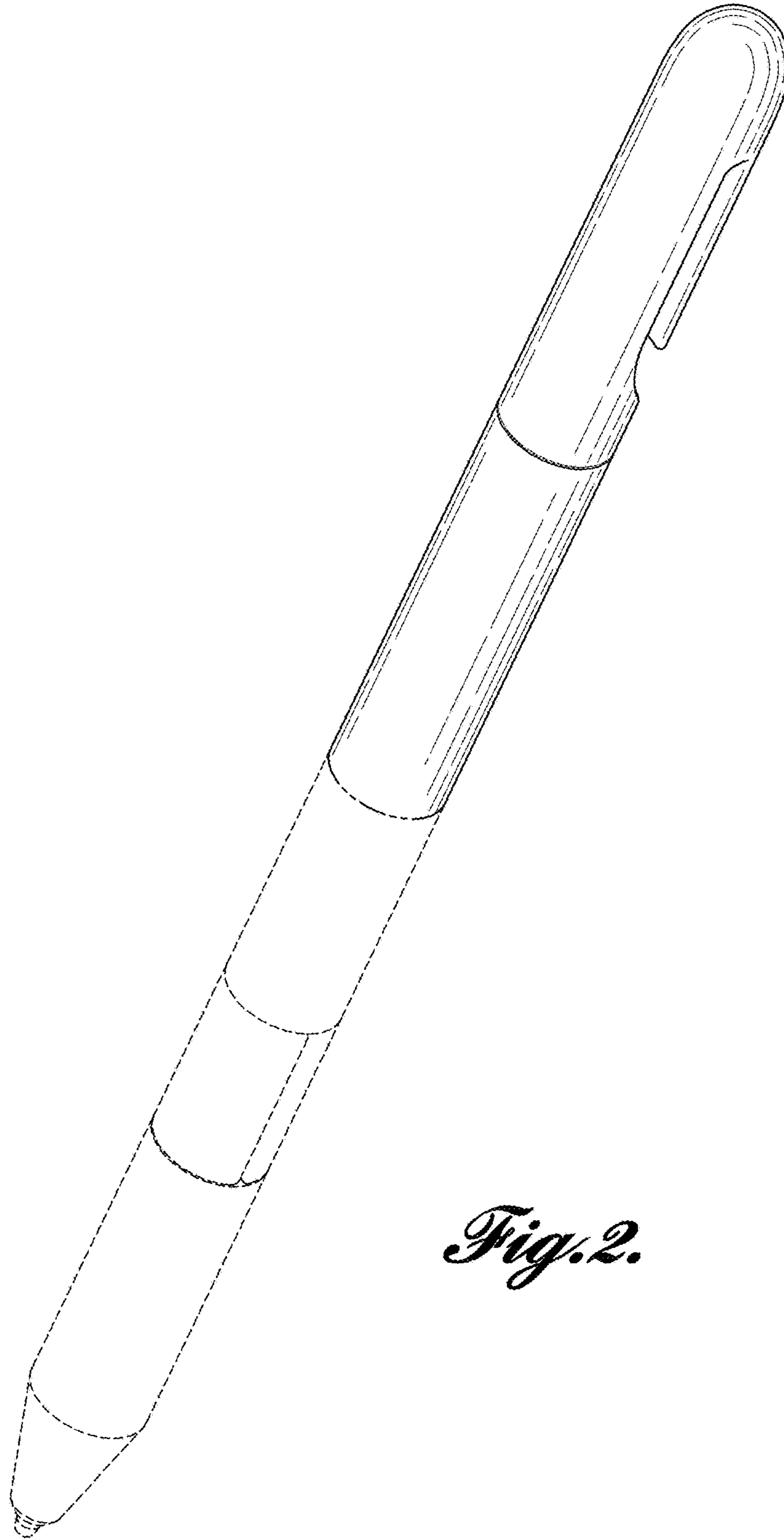

Fig. 2.

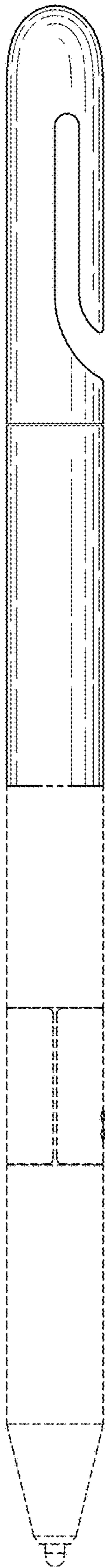

Fig. 3.

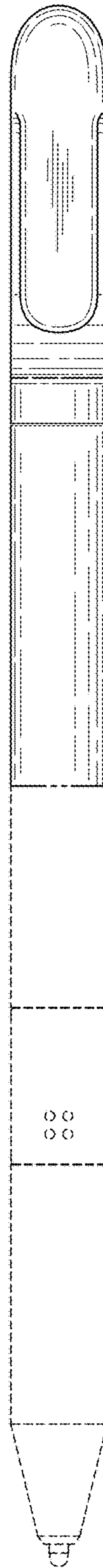

Fig. 4.

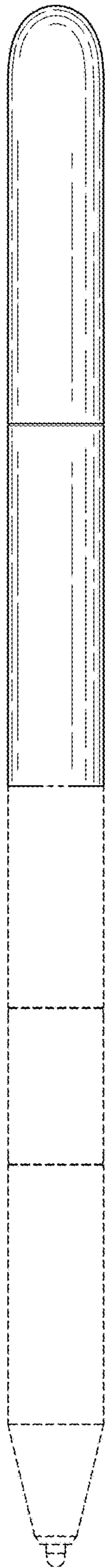

Fig. 5.

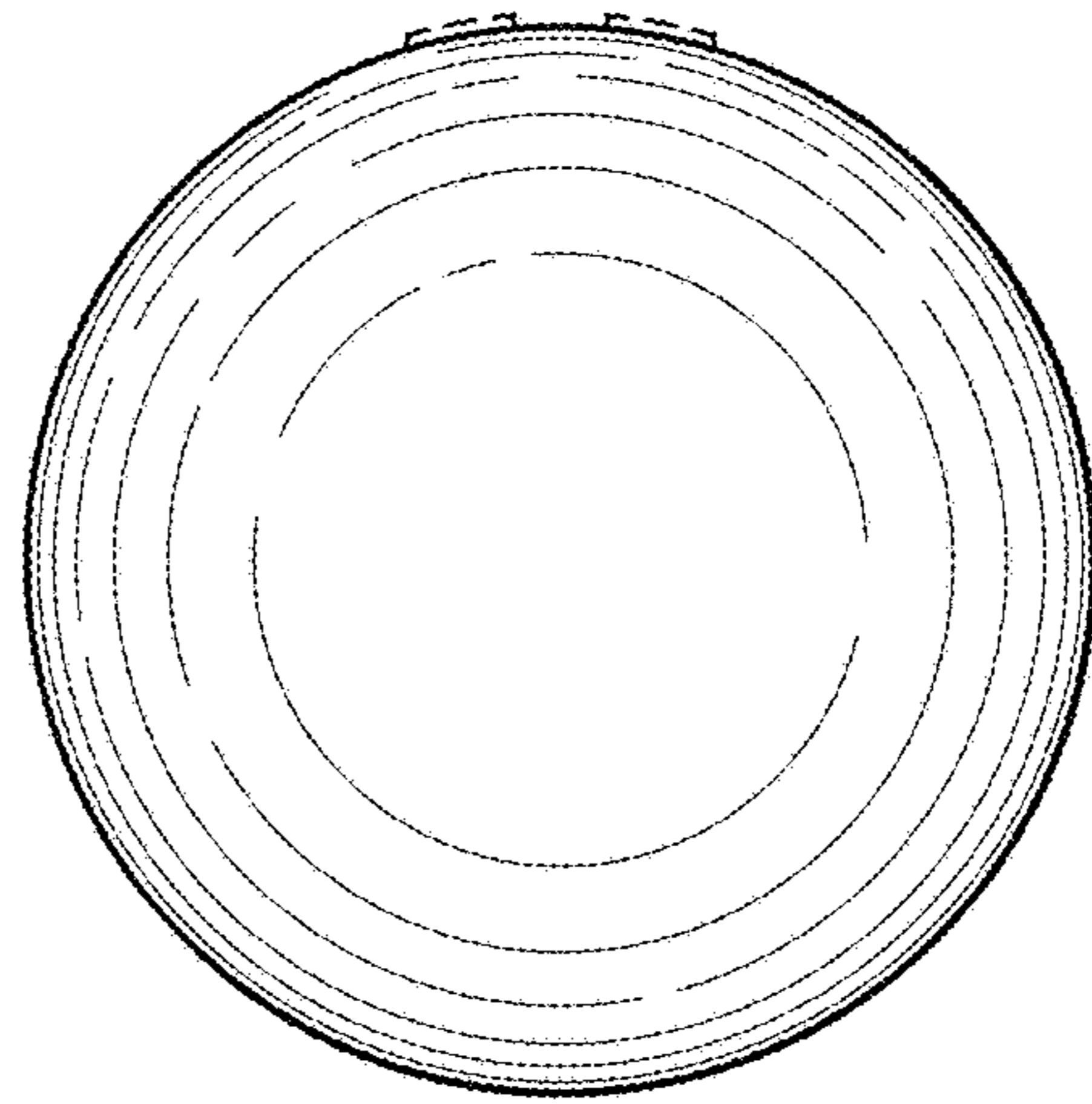

Fig. 6.

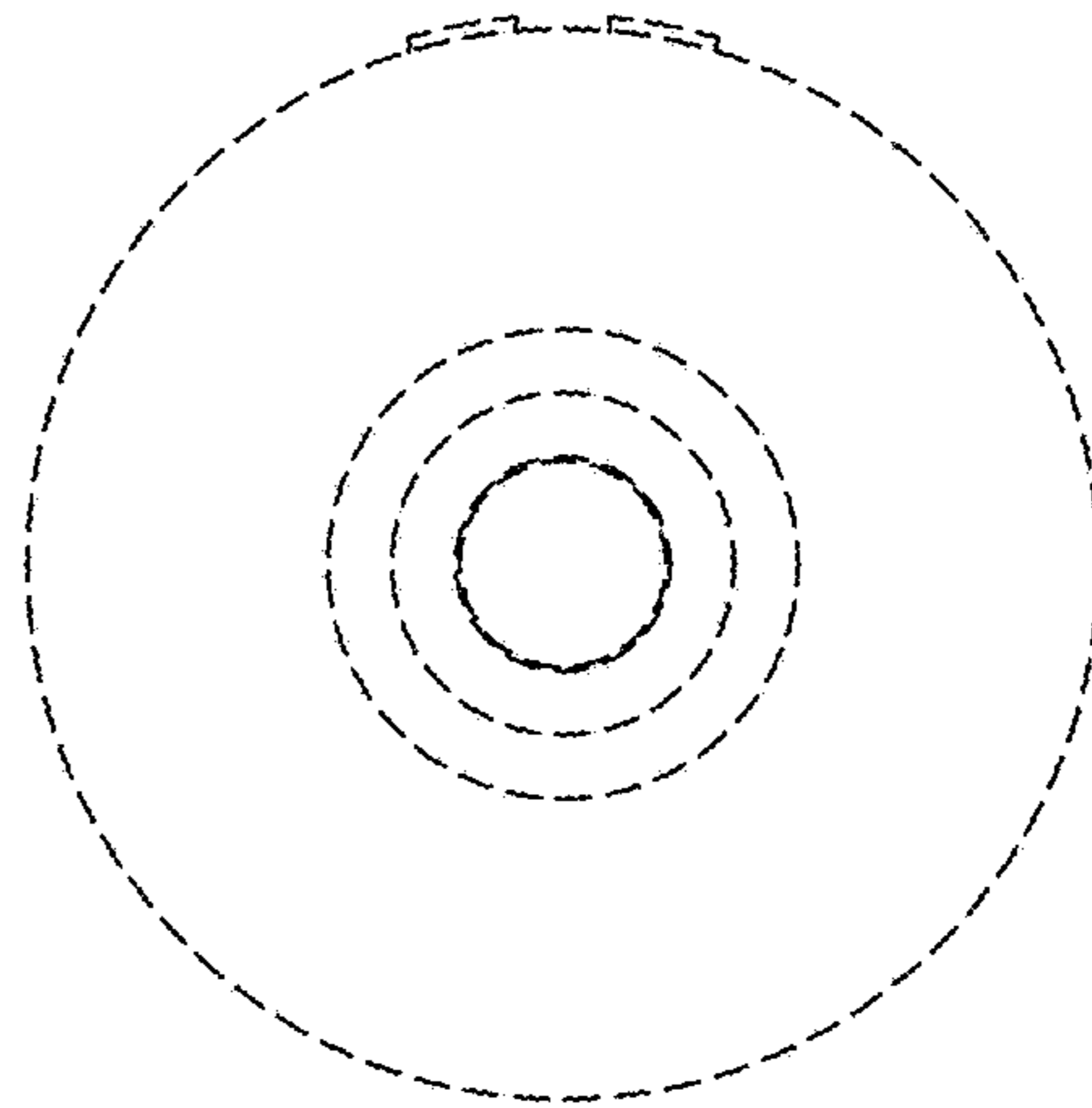

Fig. 7.