



US00D800602S

(12) **United States Design Patent** (10) **Patent No.:** **US D800,602 S**
Hsiao et al. (45) **Date of Patent:** **** Oct. 24, 2017**

- (54) **UNMANNED AERIAL VEHICLE**
- (71) Applicants: **Kanquor Hsiao**, Towaco, NJ (US);
Yufeng Hsiao, Towaco, NJ (US)
- (72) Inventors: **Kanquor Hsiao**, Towaco, NJ (US);
Yufeng Hsiao, Towaco, NJ (US)
- (**) Term: **15 Years**
- (21) Appl. No.: **29/597,702**
- (22) Filed: **Mar. 20, 2017**
- (51) **LOC (10) Cl.** **12-01**
- (52) **U.S. Cl.**
USPC **D12/16.1**; D12/328
- (58) **Field of Classification Search**
USPC D12/16.1, 319-345; D21/436, 441, 442,
D21/443, 446, 447, 448, 449, 450, 451,
D21/452, 453, 454
CPC ... B64C 27/20; B64C 27/08; B64C 2201/104;
B64C 2201/021; B64C 2201/128; B64C
2201/024; B64C 2201/141; B64C
2201/108; B64C 39/024
See application file for complete search history.

(56) **References Cited**

U.S. PATENT DOCUMENTS

- 8,967,029 B1 * 3/2015 Calvert F41H 13/00
239/171
- D741,779 S * 10/2015 Hsiao D12/16.1
- D756,842 S * 5/2016 Ashjaee D12/16.1
- D759,764 S * 6/2016 Lai D12/16.1
- D763,134 S * 8/2016 Wang D12/16.1
- D766,159 S * 9/2016 Noorani D12/345
- D768,539 S * 10/2016 Lee D12/16.1
- D784,854 S * 4/2017 Huang D12/16.1
- 2015/0321755 A1 * 11/2015 Martin B64C 27/50
244/17.23

- 2016/0001879 A1 * 1/2016 Johannesson B64C 27/50
416/142
- 2016/0236777 A1 * 8/2016 Tang B64C 39/024
- 2016/0313742 A1 * 10/2016 Wang G05D 1/0669
- 2017/0096075 A1 * 4/2017 Henry B60L 11/1822

* cited by examiner

Primary Examiner — Robert M Spear

Assistant Examiner — Marissa J Cash

(57) **CLAIM**

The ornamental design for an unmanned aerial vehicle, as shown and described.

DESCRIPTION

FIG. 1 is a front view of an unmanned aerial vehicle with landing gear in a down position, showing our new design. FIG. 2 is a rear view of an unmanned aerial vehicle with landing gear in a down position. FIG. 3 is a left-side view of an unmanned aerial vehicle with landing gear in a down position. FIG. 4 is a right-side view of an unmanned aerial vehicle with landing gear in a down position. FIG. 5 is a top view of an unmanned aerial vehicle with landing gear in a down position. FIG. 6 is a bottom view of an unmanned aerial vehicle with landing gear in a down position. FIG. 7 is a front, right, top-side perspective view of an unmanned aerial vehicle with landing gear in a down position. FIG. 8 is a rear, right bottom-side perspective view of an unmanned aerial vehicle with landing gear in a down position. FIG. 9 is a front, right, top-side perspective view of an unmanned aerial vehicle with landing gear in an up position; and, FIG. 10 is a rear, right bottom-side perspective view of an unmanned aerial vehicle with landing gear in an up position. In the drawings, the broken lines depict environmental subject matter only and form no part of the claimed design.

1 Claim, 10 Drawing Sheets

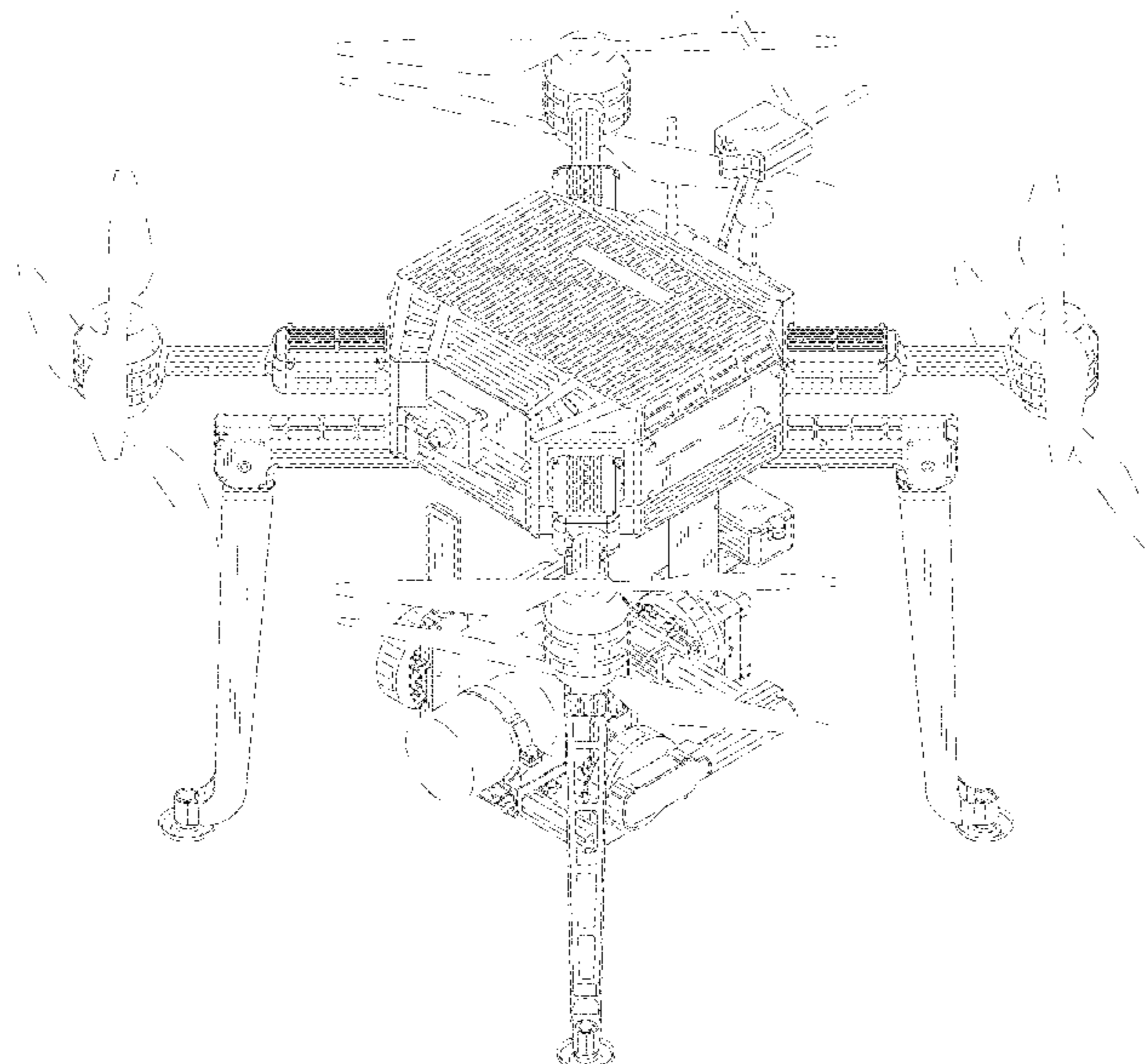

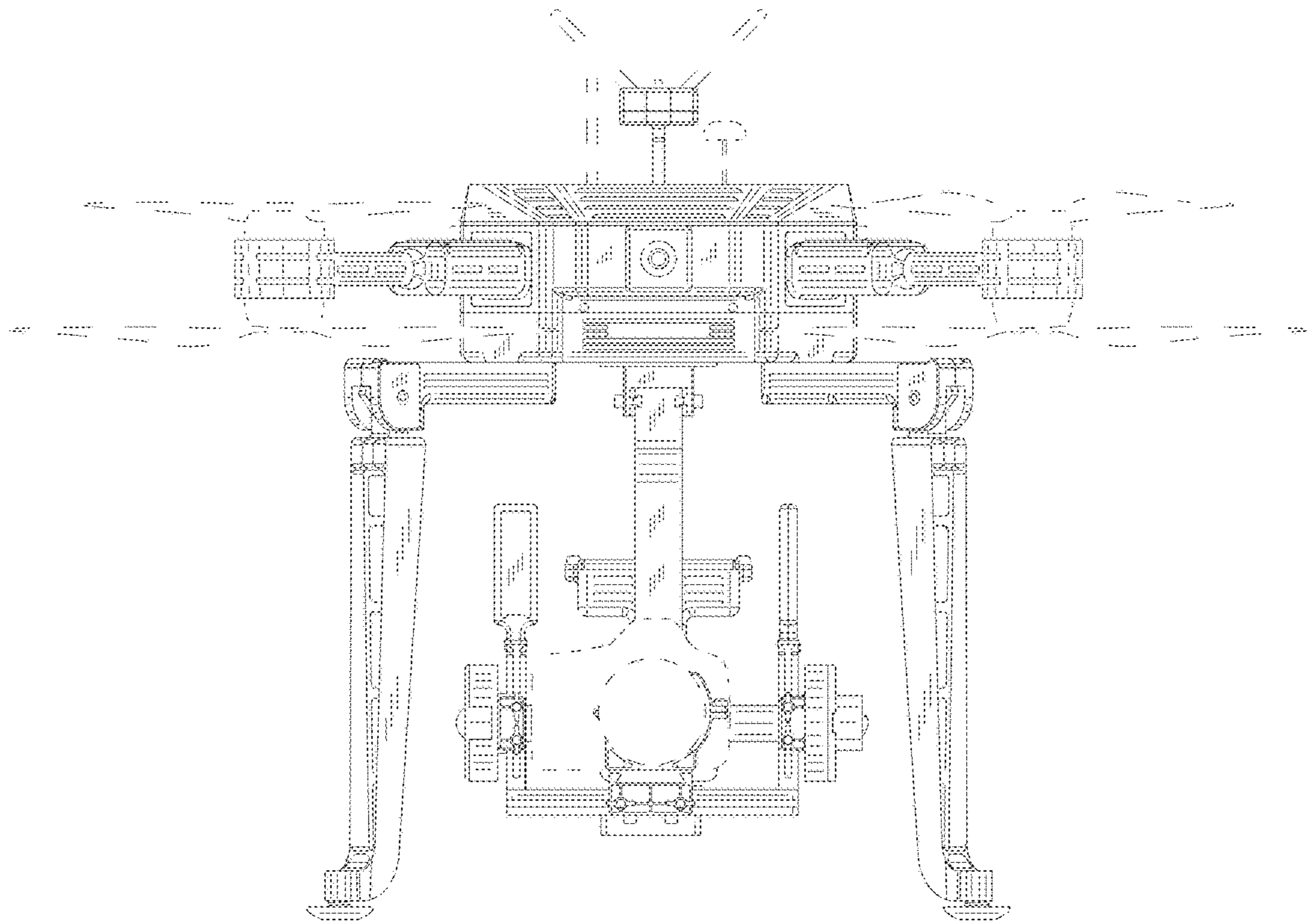

Fig. 1

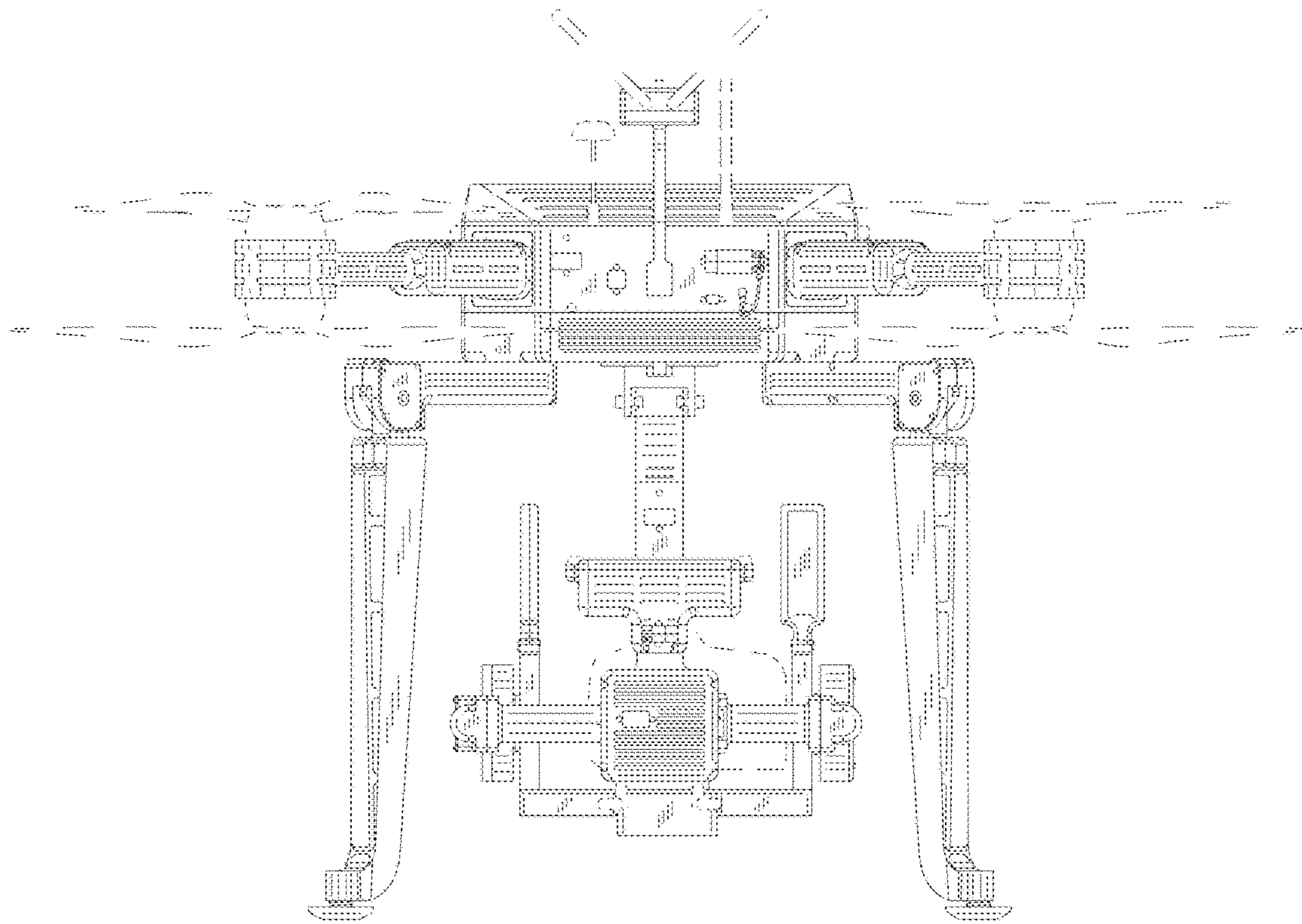

Fig. 2

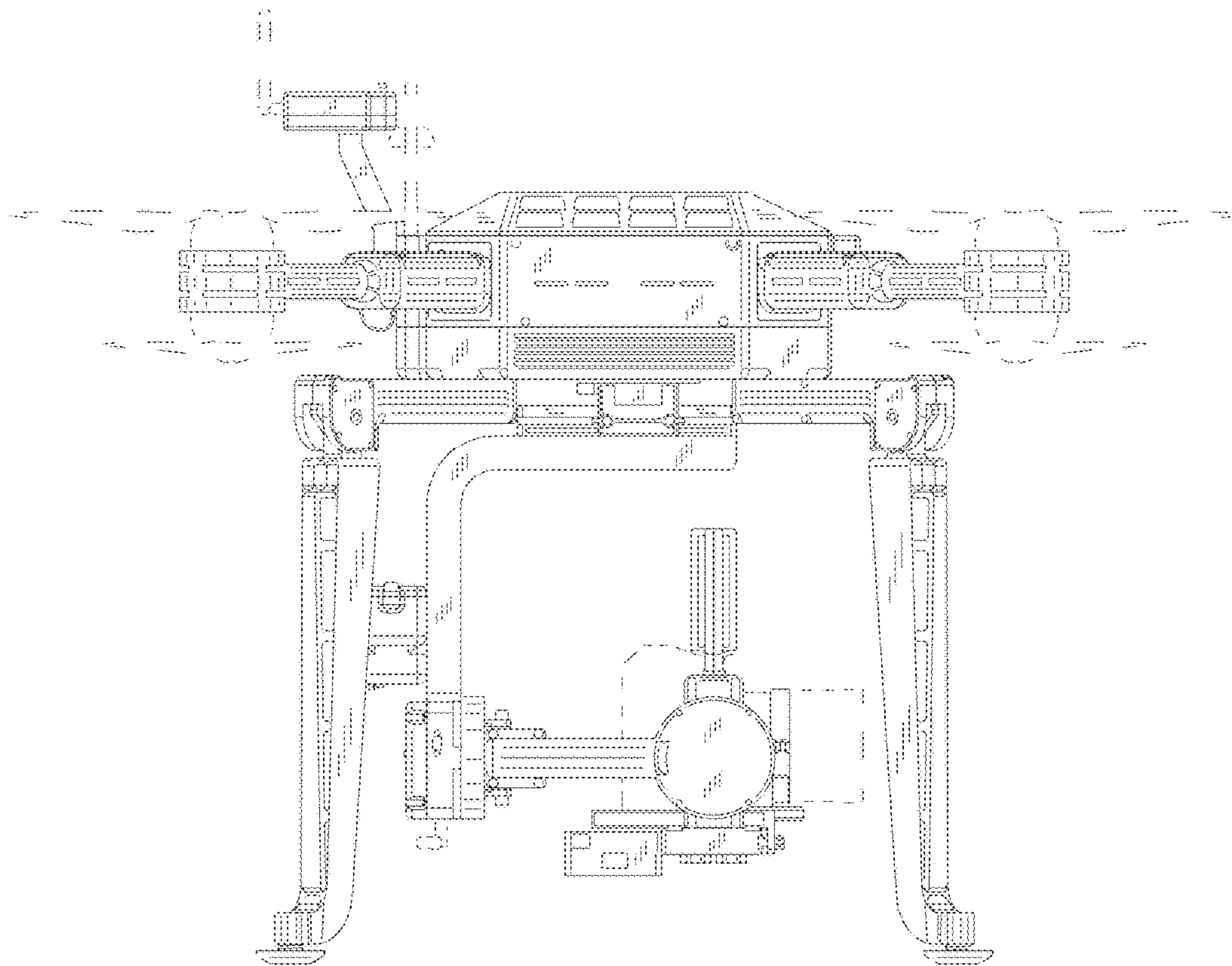

Fig. 3

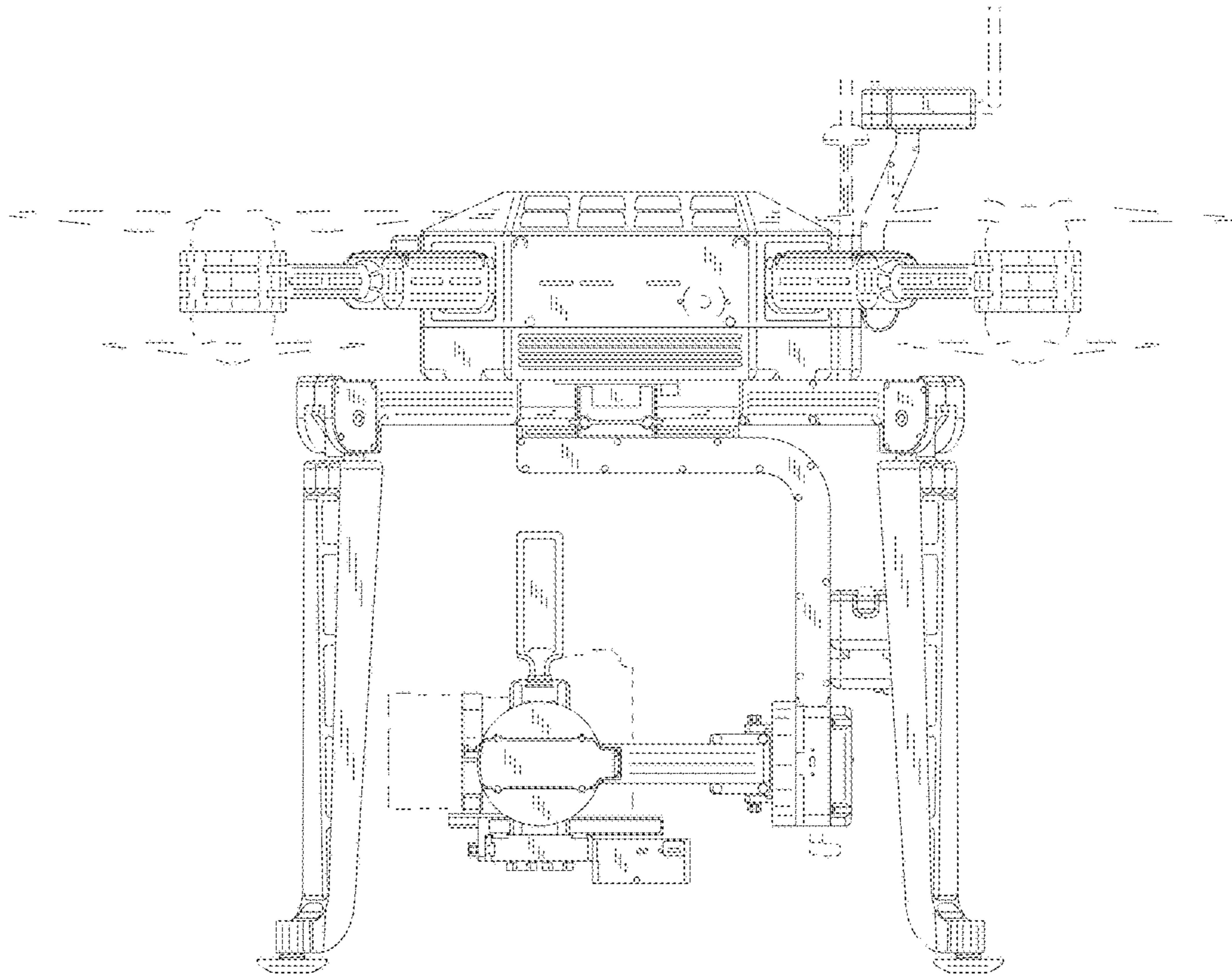

Fig. 4

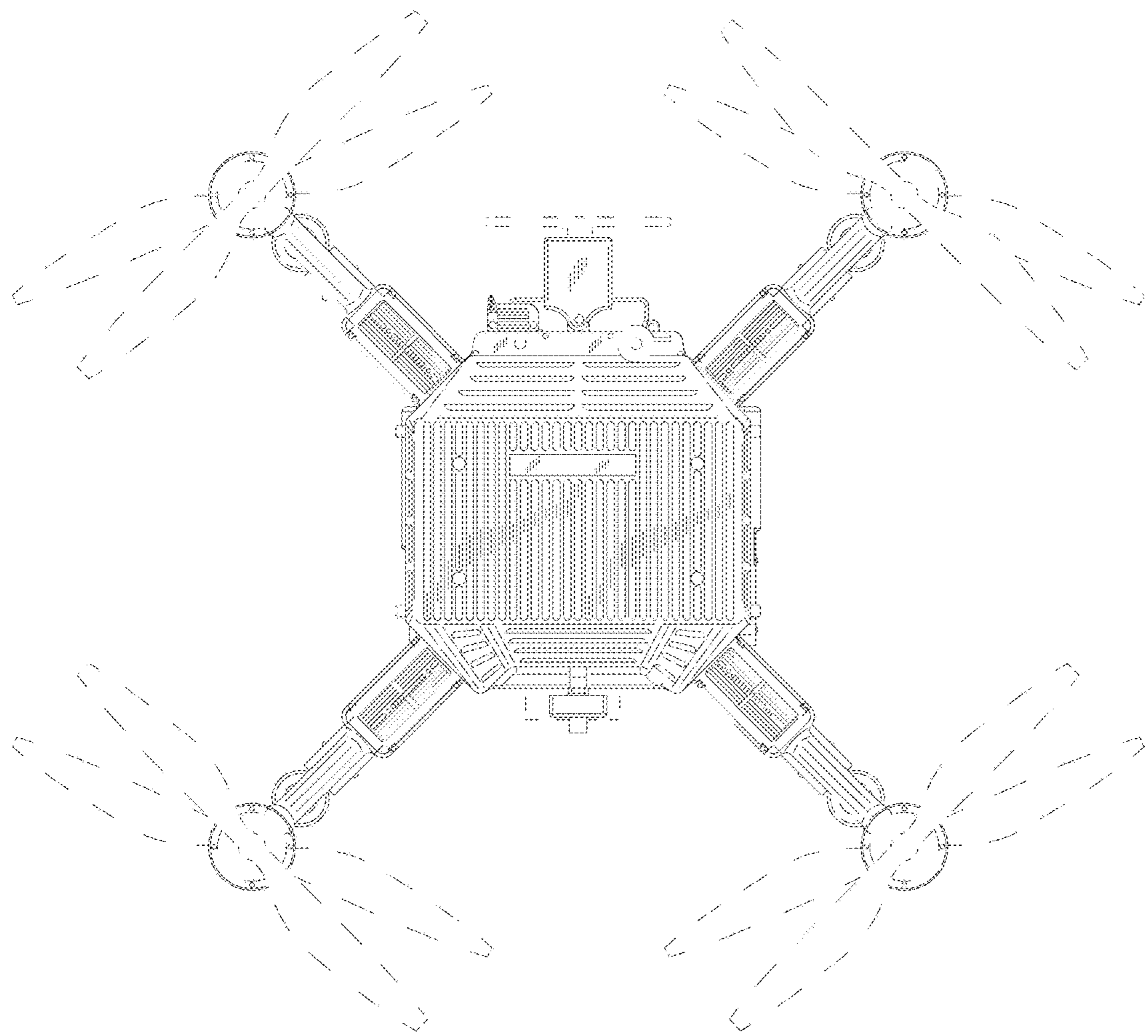

Fig. 5

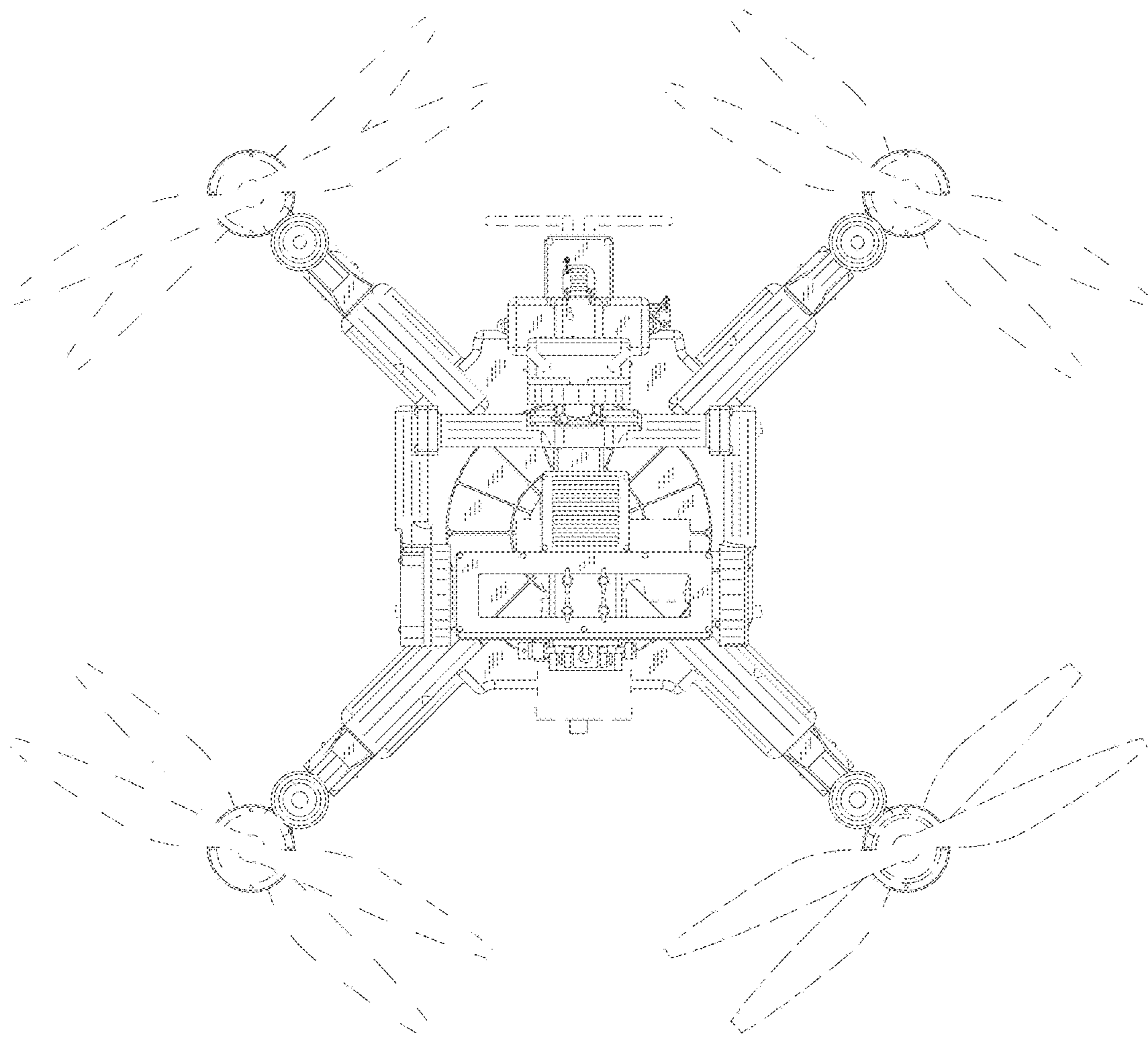

Fig. 6

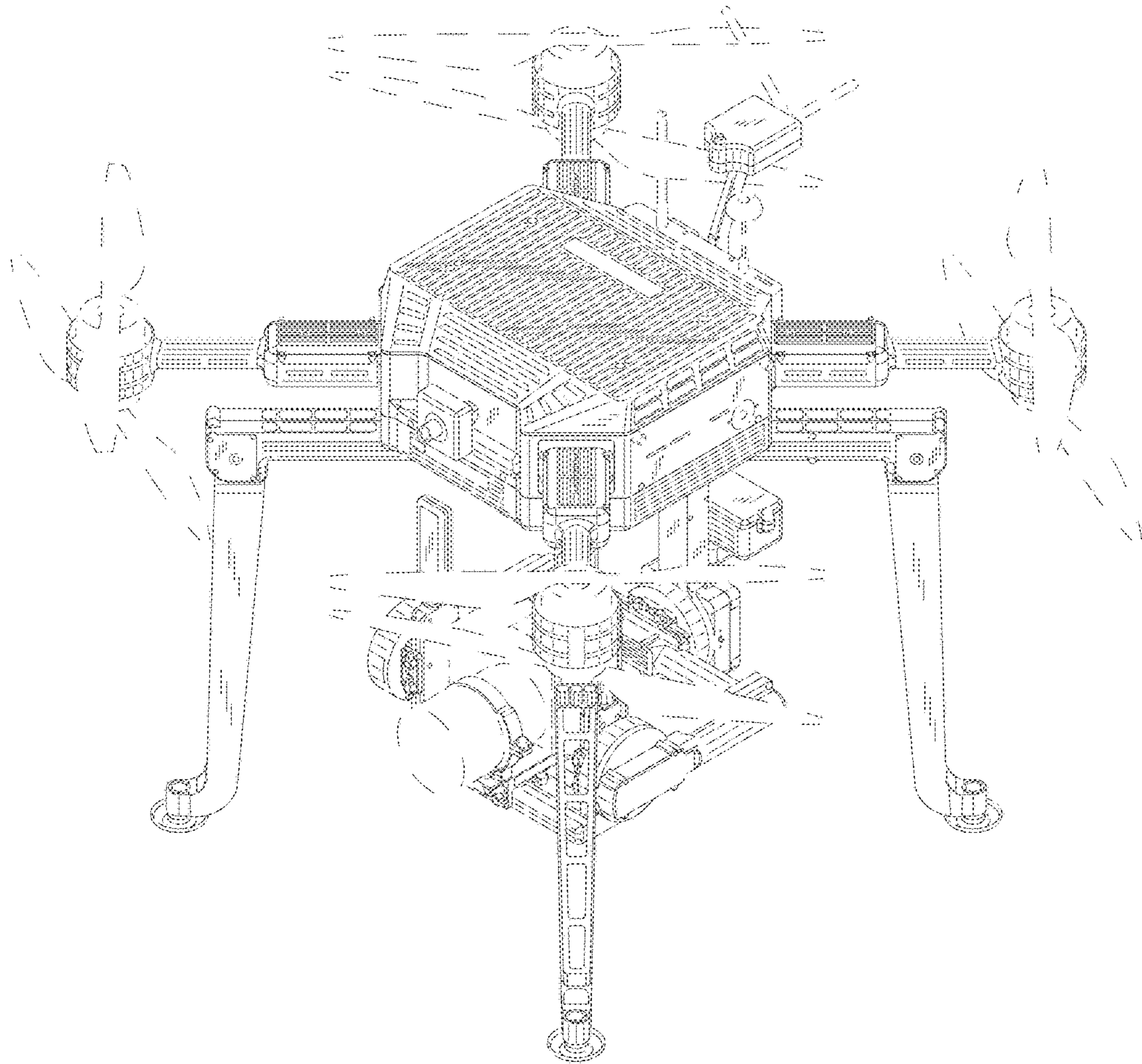

Fig. 7

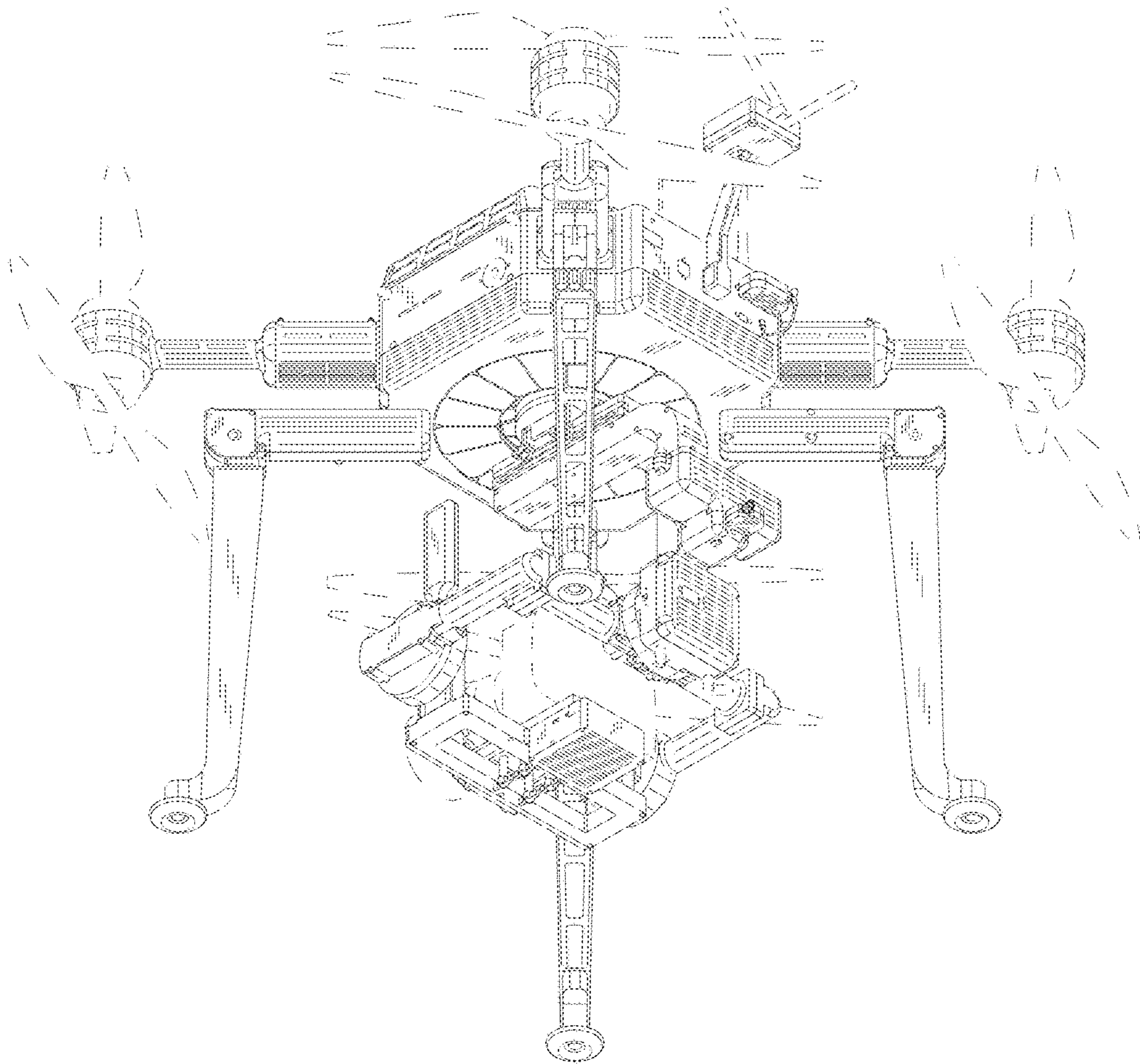

Fig. 8

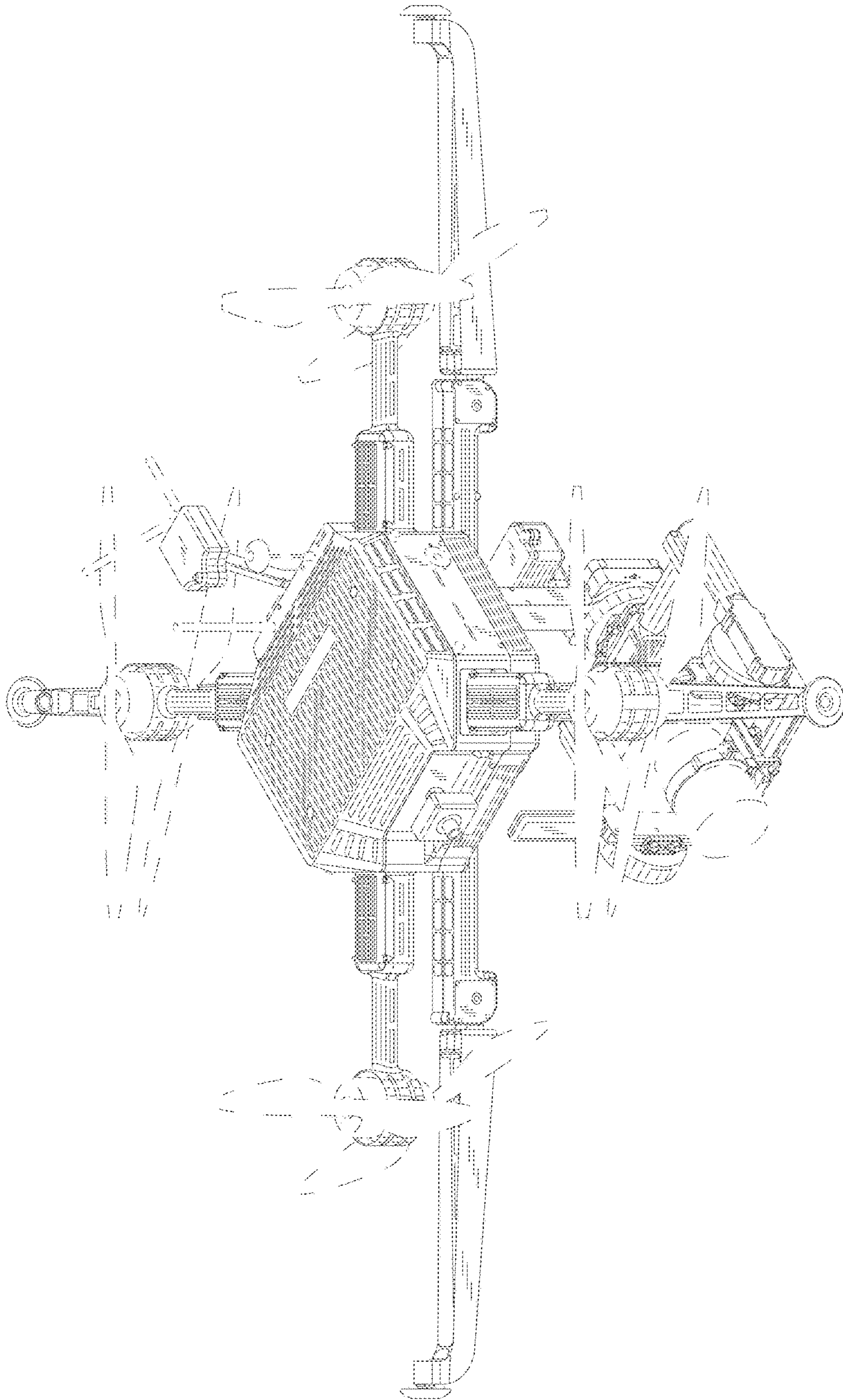

Fig. 9

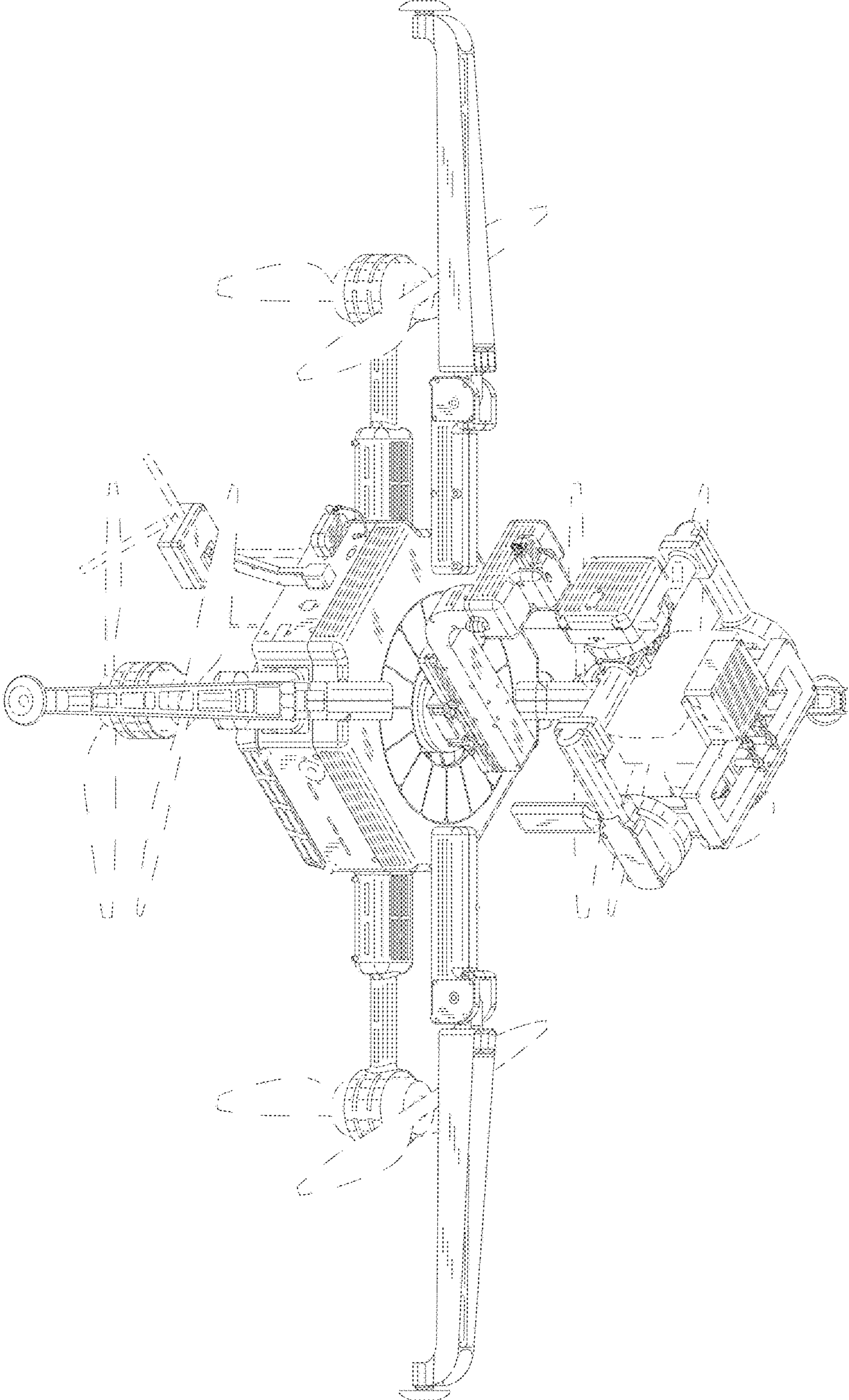

Fig. 10