



US00D800464S

(12) **United States Design Patent**
Larabie et al.

(10) **Patent No.:** **US D800,464 S**

(45) **Date of Patent:** **** Oct. 24, 2017**

- (54) **AIRCRAFT PASSENGER SEAT**
- (71) Applicants: **Ron Larabie**, Henderson, NV (US);
Dave Miller, Henderson, NV (US)
- (72) Inventors: **Ron Larabie**, Henderson, NV (US);
Dave Miller, Henderson, NV (US)
- (**) Term: **15 Years**
- (21) Appl. No.: **29/574,281**
- (22) Filed: **Aug. 12, 2016**
- (51) **LOC (10) Cl.** **06-01**
- (52) **U.S. Cl.**
USPC **D6/356**
- (58) **Field of Classification Search**
USPC D6/333, 334, 344, 348, 356, 360–366,
D6/368, 369–371, 374, 377, 380, 381,
D6/708, 716; D12/52; D11/184;
D21/521, 534–539, 674, 676, 687, 688,
D21/690, 828; D23/292; D30/118
CPC ... B64D 11/06; B64D 11/064; B64D 11/0602;
B64D 11/0606; B64D 11/0643; B64D
11/0647; B60N 2/01583; B60N 2/4221;
B60N 2/4606; B60N 2/7011; A47C
1/036; A47C 1/037; A47C 1/02; A47C
1/14; A47C 1/16; A47C 1/143; A47C
1/146; A47C 1/0342; A47C 7/26; A47C
7/506; A47C 7/021; A47C 7/16; A47C
7/18; A47C 7/54; A47C 7/62; A47C 7/70;
A47C 7/744; Y10T 29/49826
See application file for complete search history.

(56) **References Cited**

U.S. PATENT DOCUMENTS

- 2,595,582 A * 5/1952 Hoven A47C 7/26
297/302.4
- D180,226 S * 5/1957 Ensign D6/360
- 2,984,293 A * 5/1961 Bontempi A47C 1/037
297/61

- 2,986,201 A * 5/1961 McCartan A47C 7/506
297/423.31
- D208,468 S * 9/1967 Okiyama D6/360
- D216,305 S * 12/1969 Gazit D6/368
- D222,350 S * 10/1971 Sundberg D6/368
- D228,104 S * 8/1973 Blodee D6/368
- 4,440,441 A * 4/1984 Marrujo B60N 2/4221
188/371
- D347,332 S * 5/1994 Donnelly D6/362
- D347,947 S * 6/1994 Donnelly D6/368
- D349,194 S * 8/1994 Hollis D6/368
- D352,400 S * 11/1994 Yamazaki D6/334

(Continued)

Primary Examiner — Kevin K Rudzinski

Assistant Examiner — Paul D Bohannon

(74) *Attorney, Agent, or Firm* — Lightbulb IP, LLC

(57) **CLAIM**

The ornamental design for an aircraft passenger seat, as shown and described.

DESCRIPTION

FIG. 1 is a perspective view of an aircraft passenger seat. FIG. 2 is a perspective view of an aircraft passenger seat. FIG. 3 is a front view of an aircraft passenger seat. FIG. 4 is a side view of an aircraft passenger seat, with the opposite side view being a mirror image thereof. FIG. 5 is a back view of an aircraft passenger seat. FIG. 6 is a top view of an aircraft passenger seat. FIG. 7 is a bottom view of an aircraft passenger seat. FIG. 8 is a perspective view of an aircraft passenger seat. FIG. 9 is a perspective view of an aircraft passenger seat. FIG. 10 is a front view of an aircraft passenger seat. FIG. 11 is a side view of an aircraft passenger seat, with the opposite side view being a mirror image thereof. FIG. 12 is a back view of an aircraft passenger seat. FIG. 13 is a top view of an aircraft passenger seat; and, FIG. 14 is a bottom view of an aircraft passenger seat. The broken lines showing portions of the aircraft passenger seat form no part of the claimed design.

1 Claim, 14 Drawing Sheets

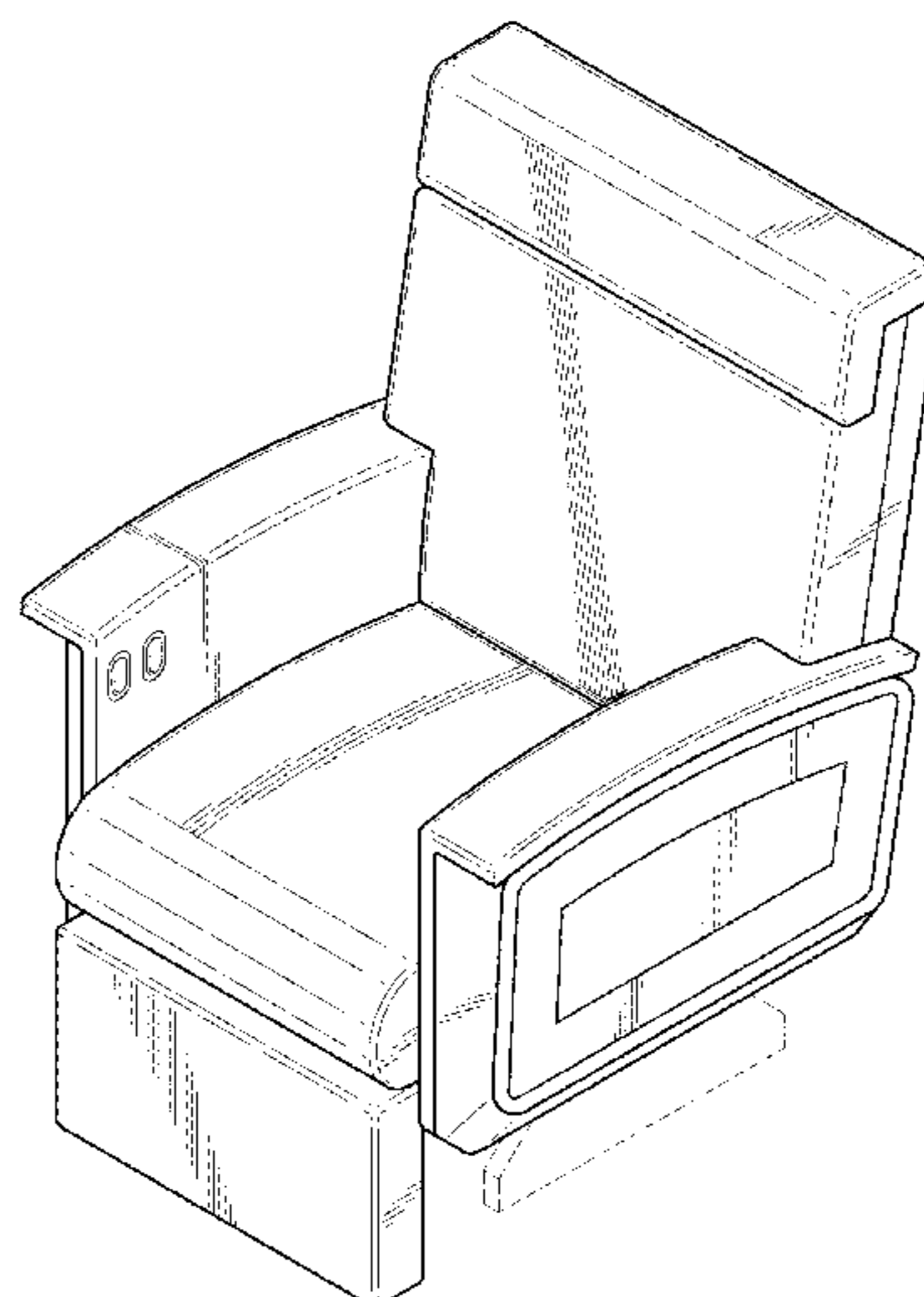
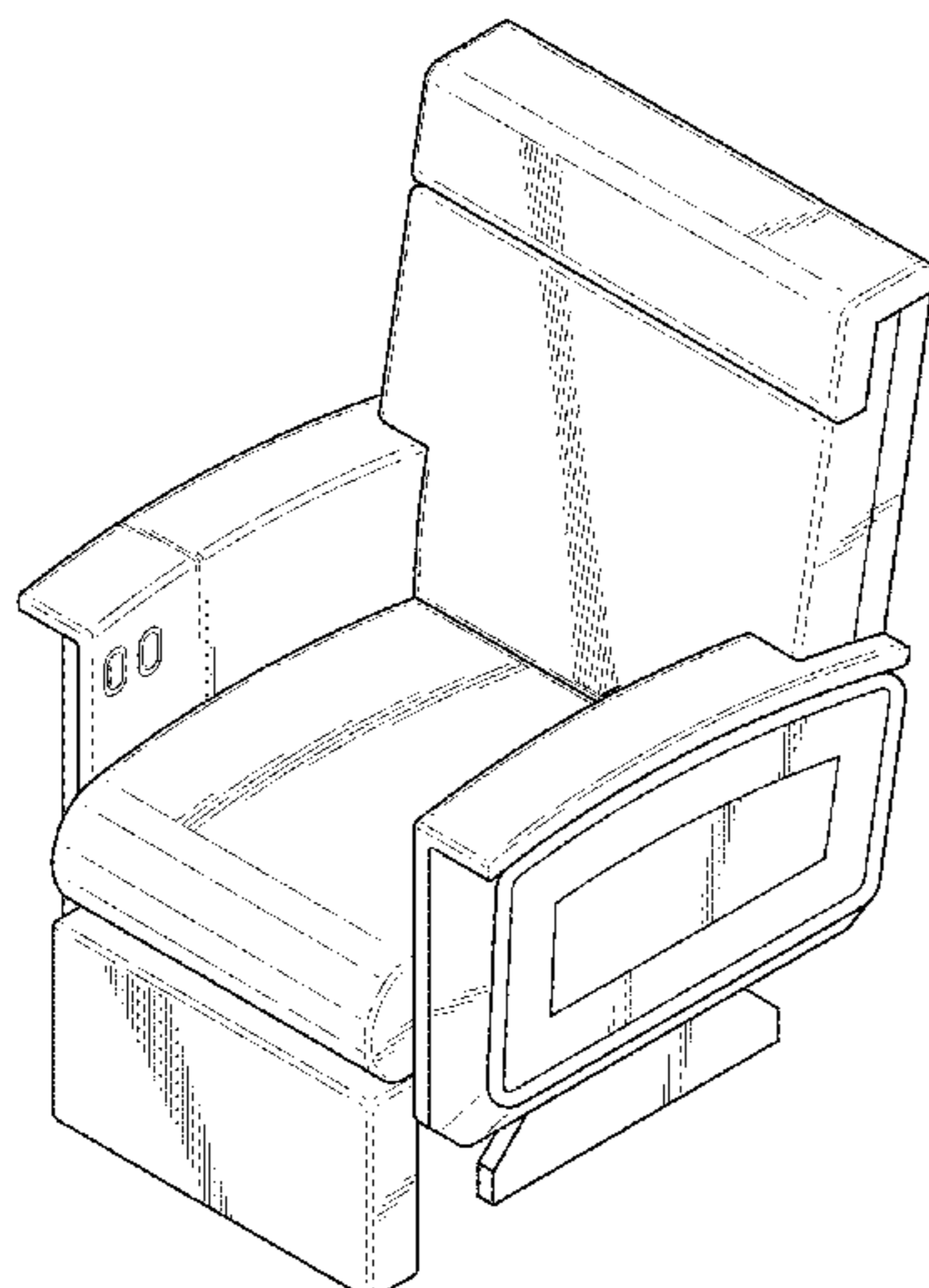

(56)

References Cited

U.S. PATENT DOCUMENTS

D672,980 S * 12/2012 Mitjans D6/364
D681,969 S * 5/2013 Mitjans D6/364
D723,819 S * 3/2015 Takahashi D6/356
2002/0033622 A1* 3/2002 Jarnail B60N 2/4221
297/216.2
2006/0091690 A1* 5/2006 Boyina B60N 2/01583
296/65.09
2008/0290715 A1* 11/2008 Fullerton B60N 2/7011
297/452.18
2014/0300147 A1* 10/2014 Suhre B60N 2/4606
297/170
2016/0288910 A1* 10/2016 Udriste B64D 11/064

* cited by examiner

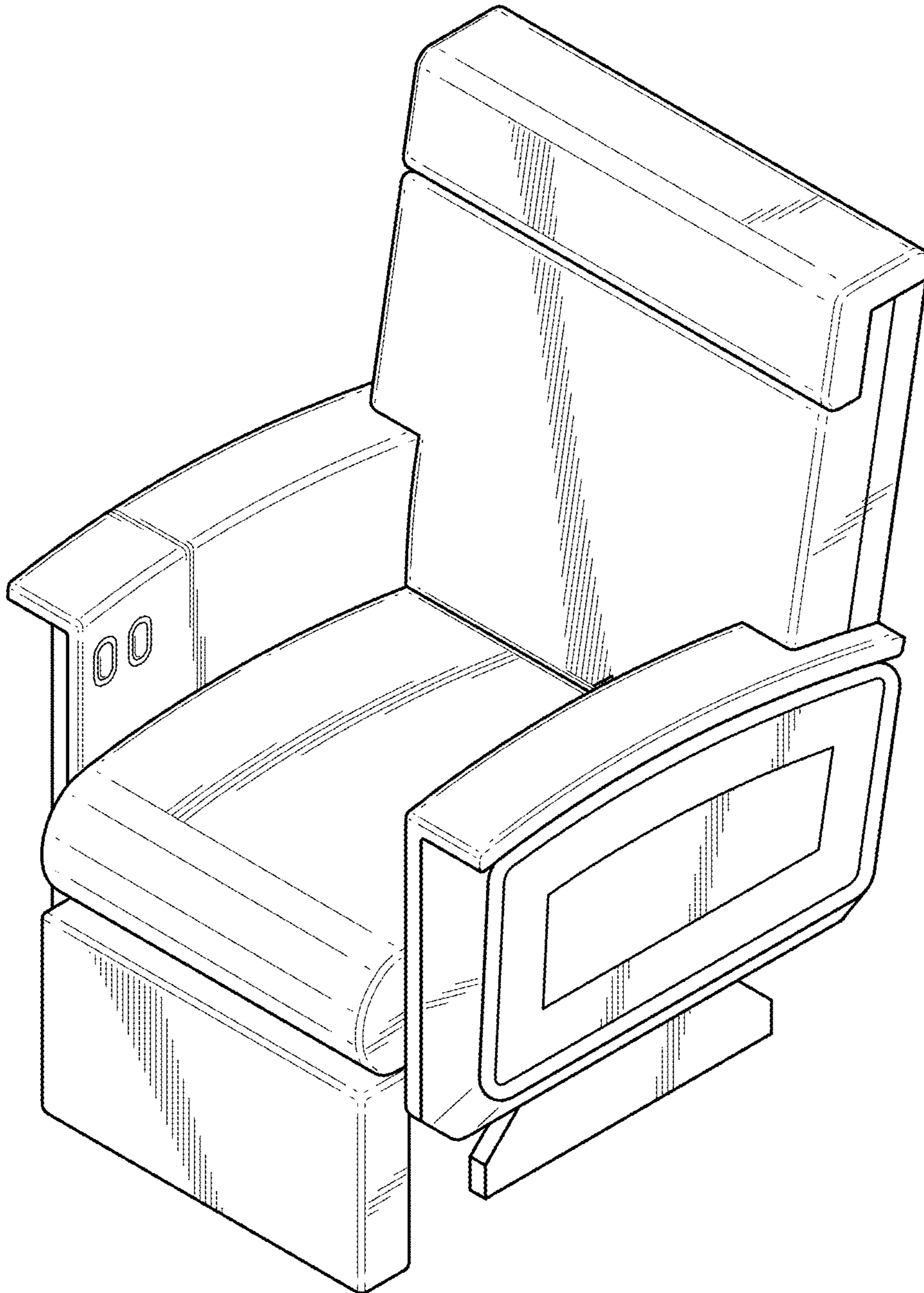

FIG. 1

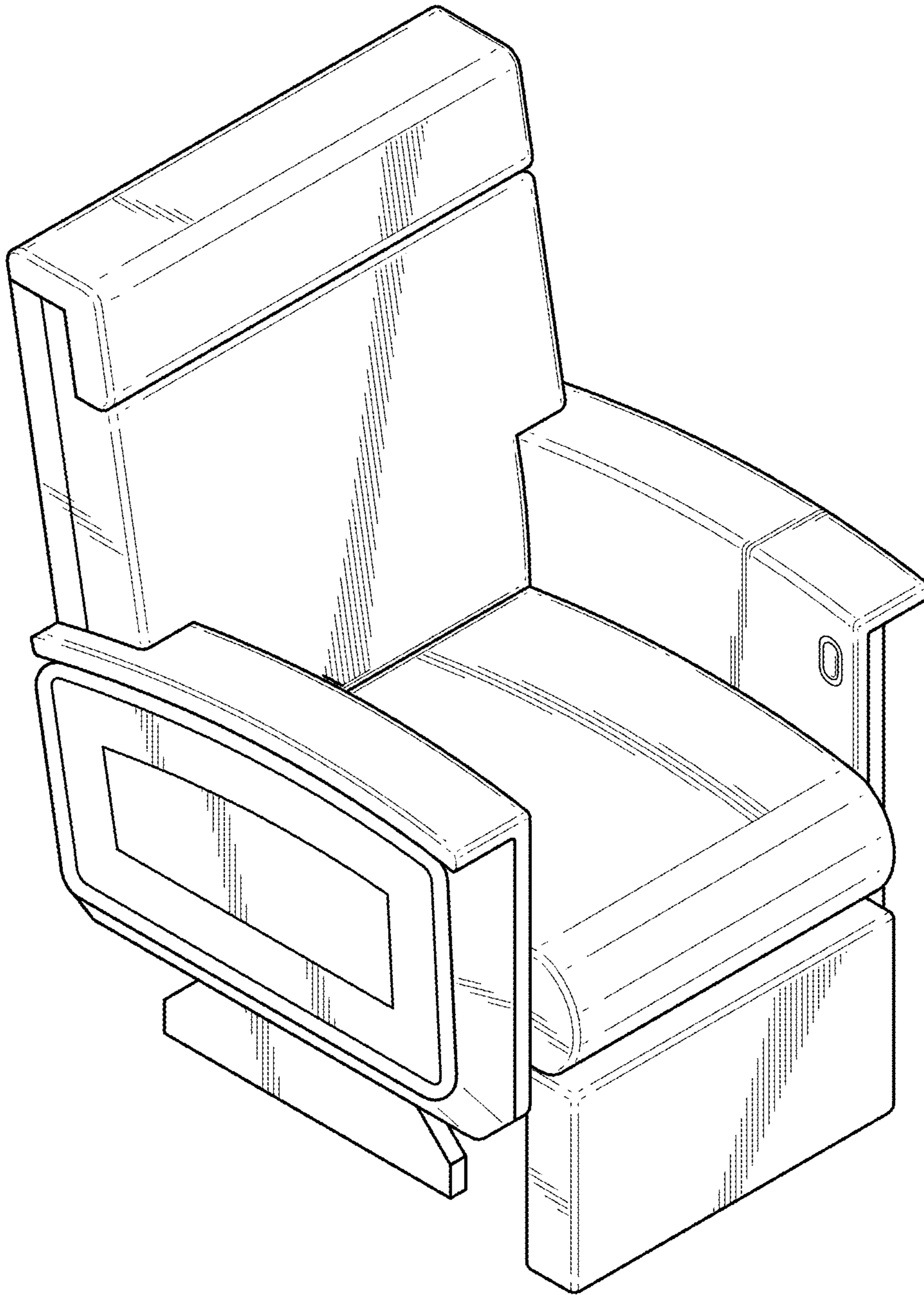

FIG. 2

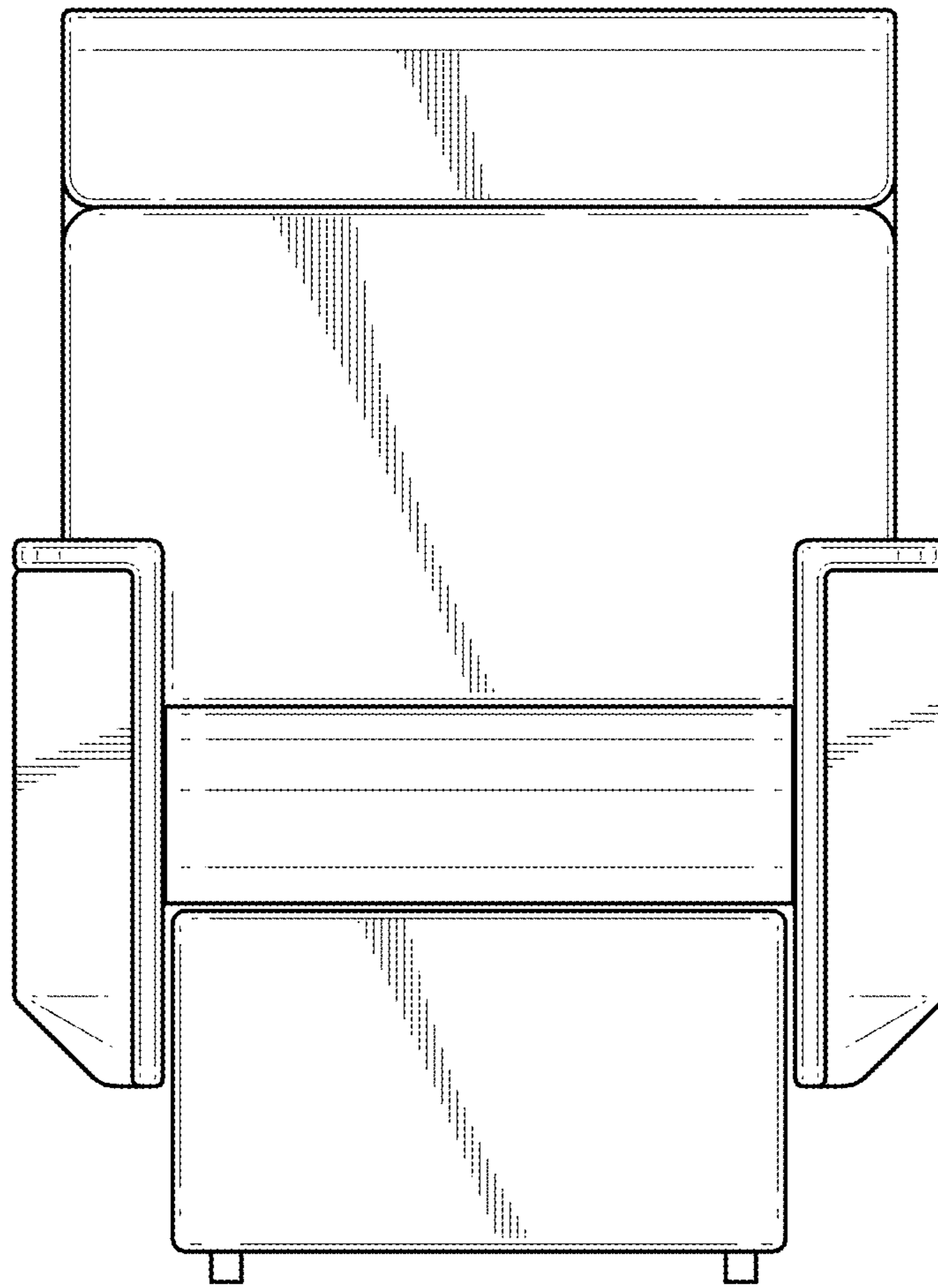

FIG. 3

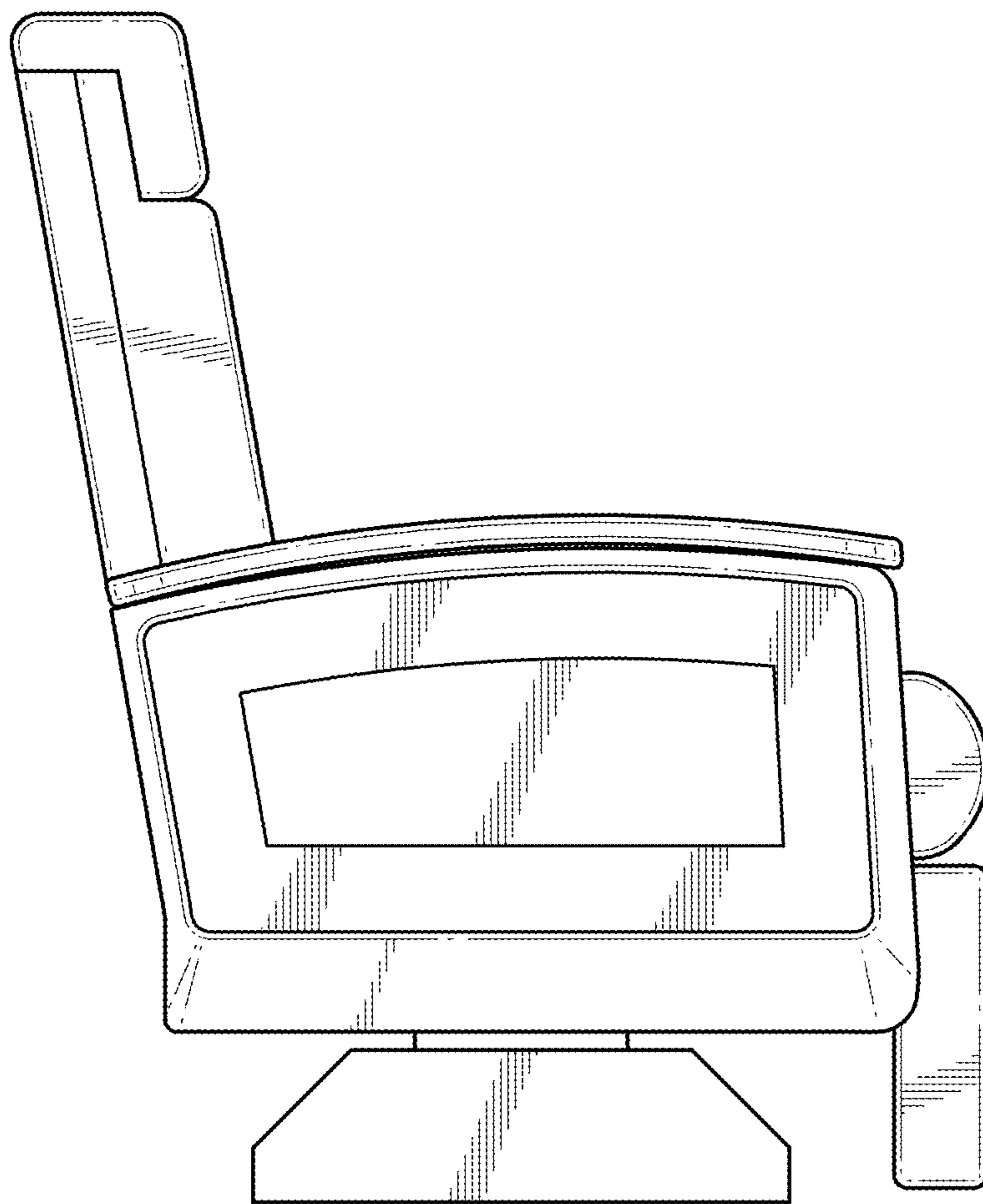

FIG. 4

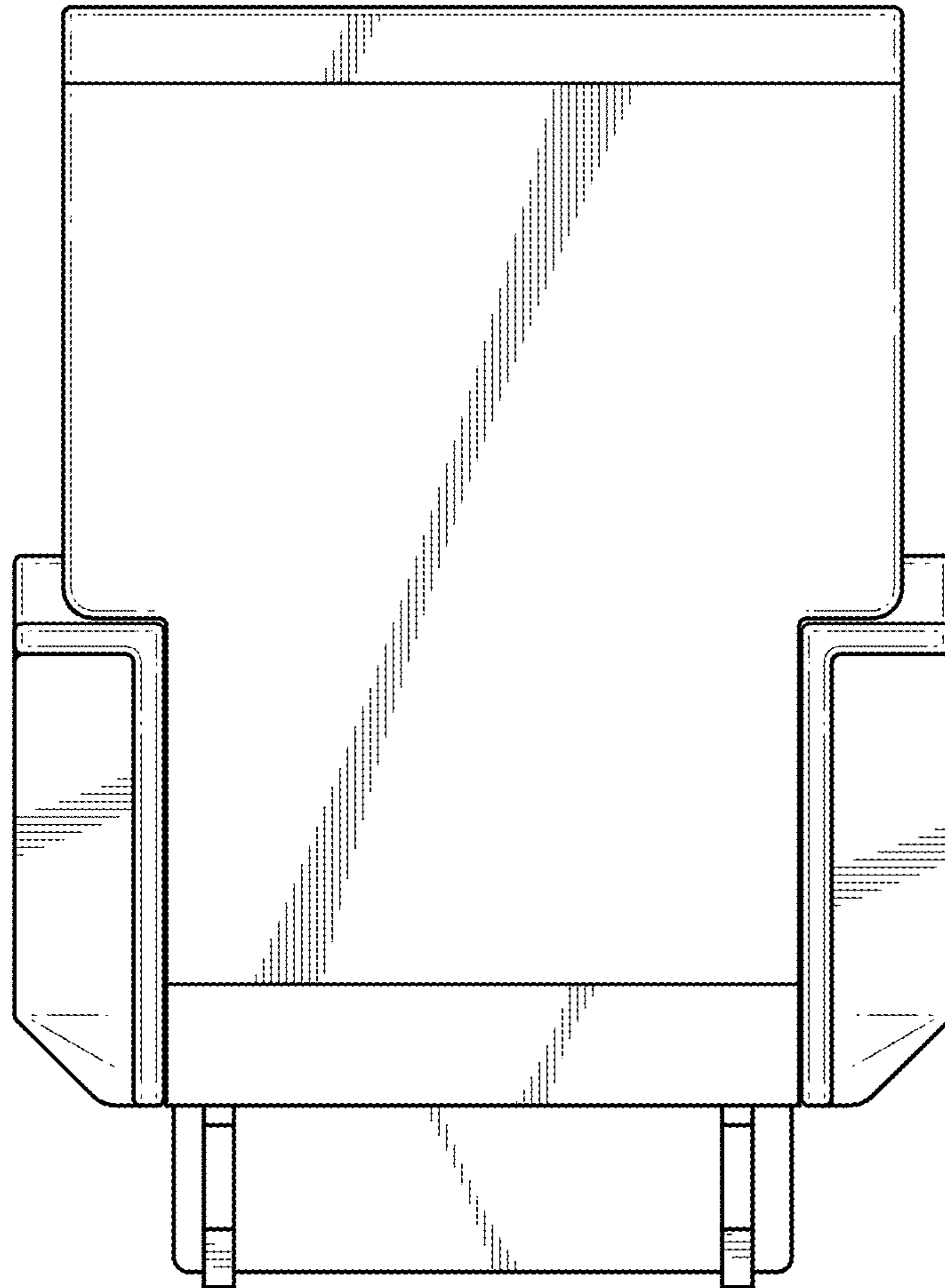

FIG. 5

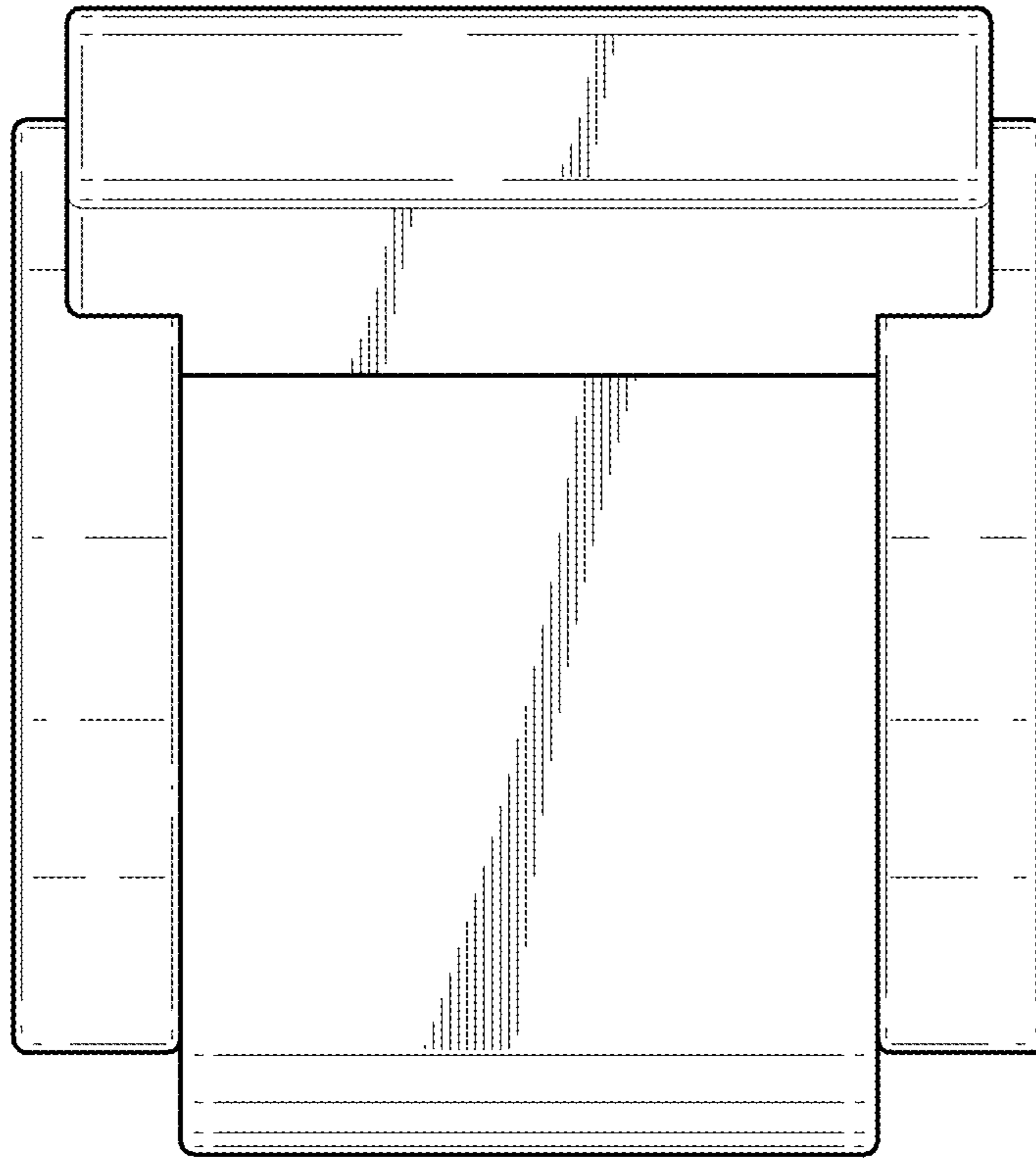

FIG. 6

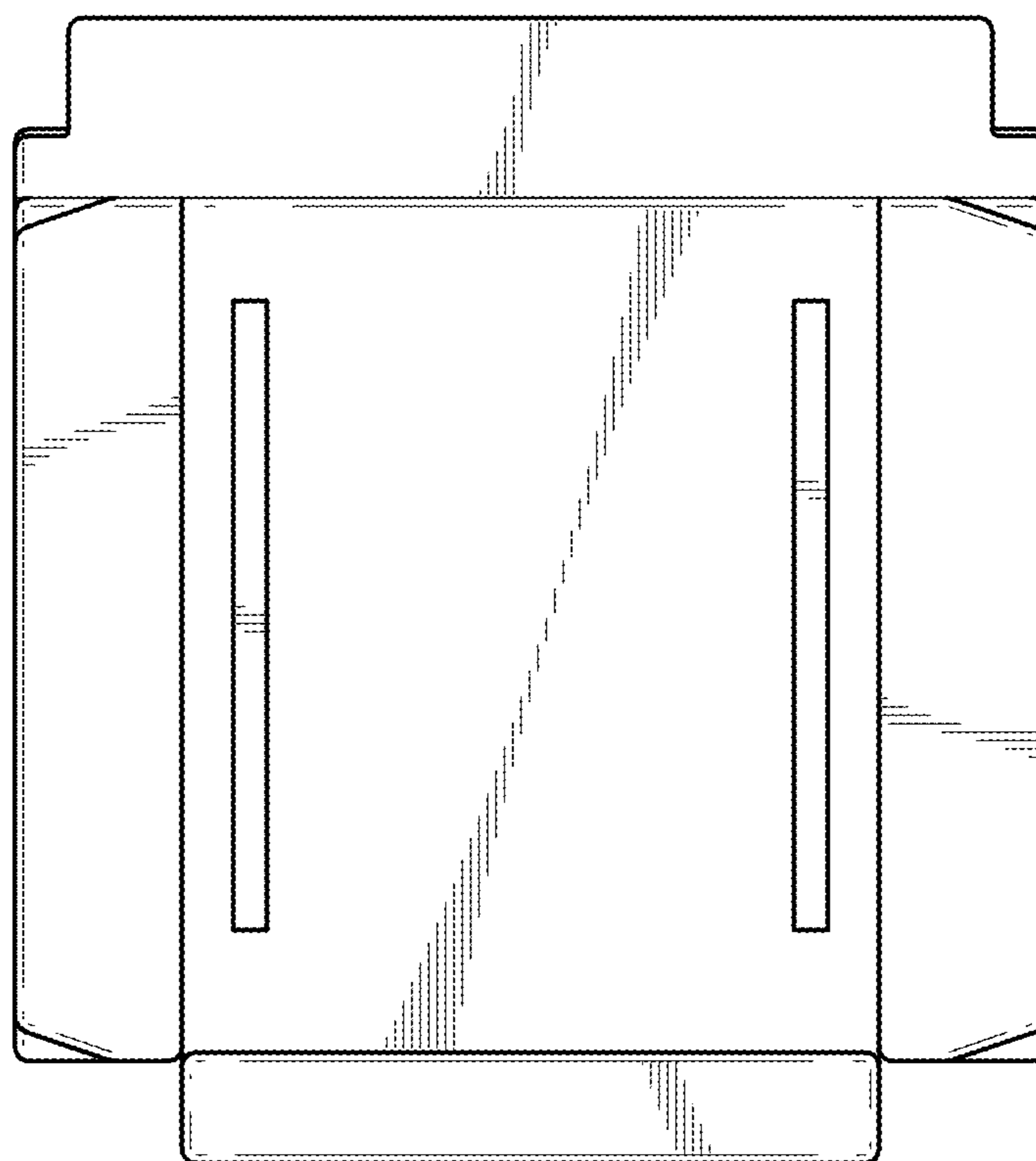

FIG. 7

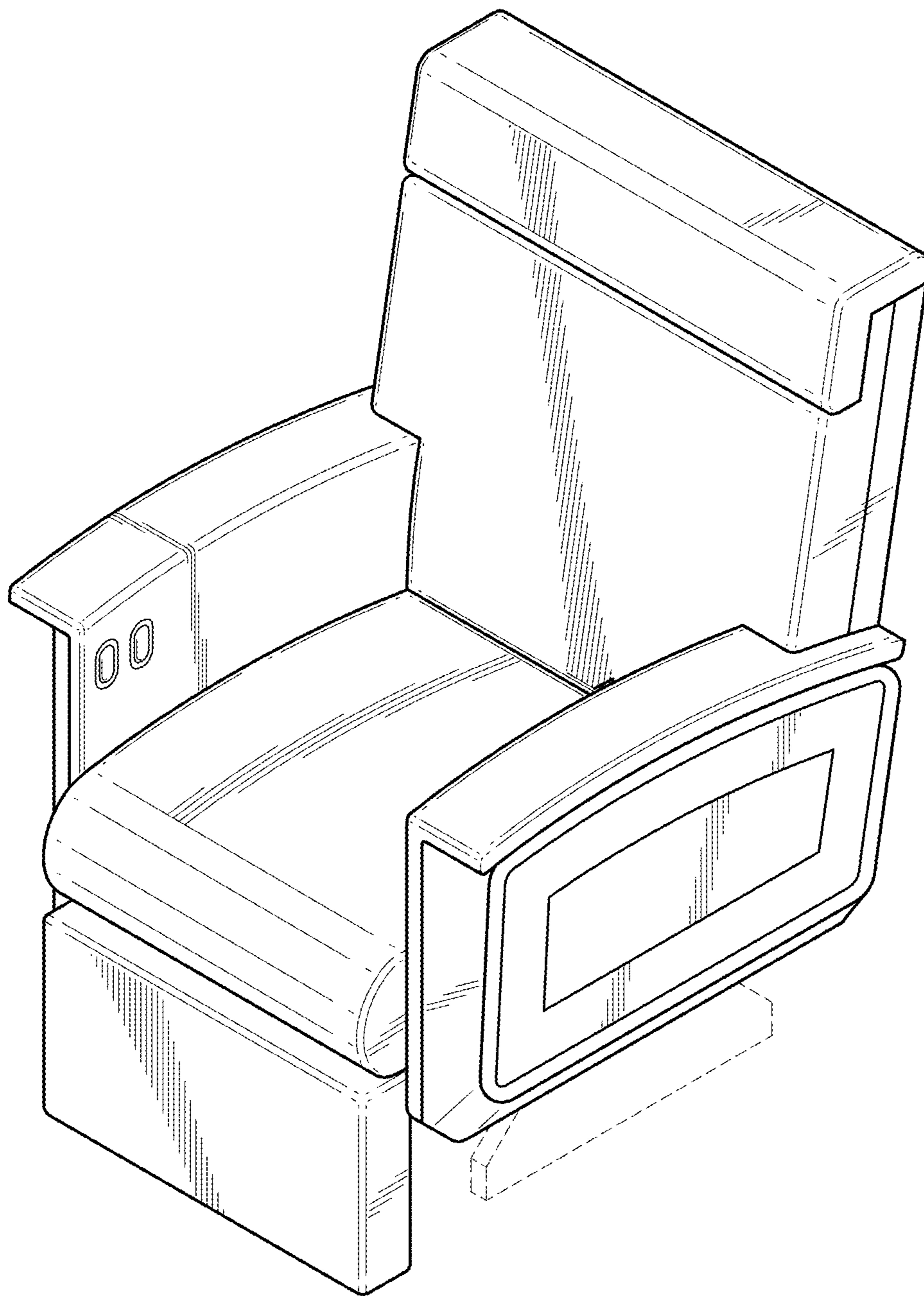

FIG. 8

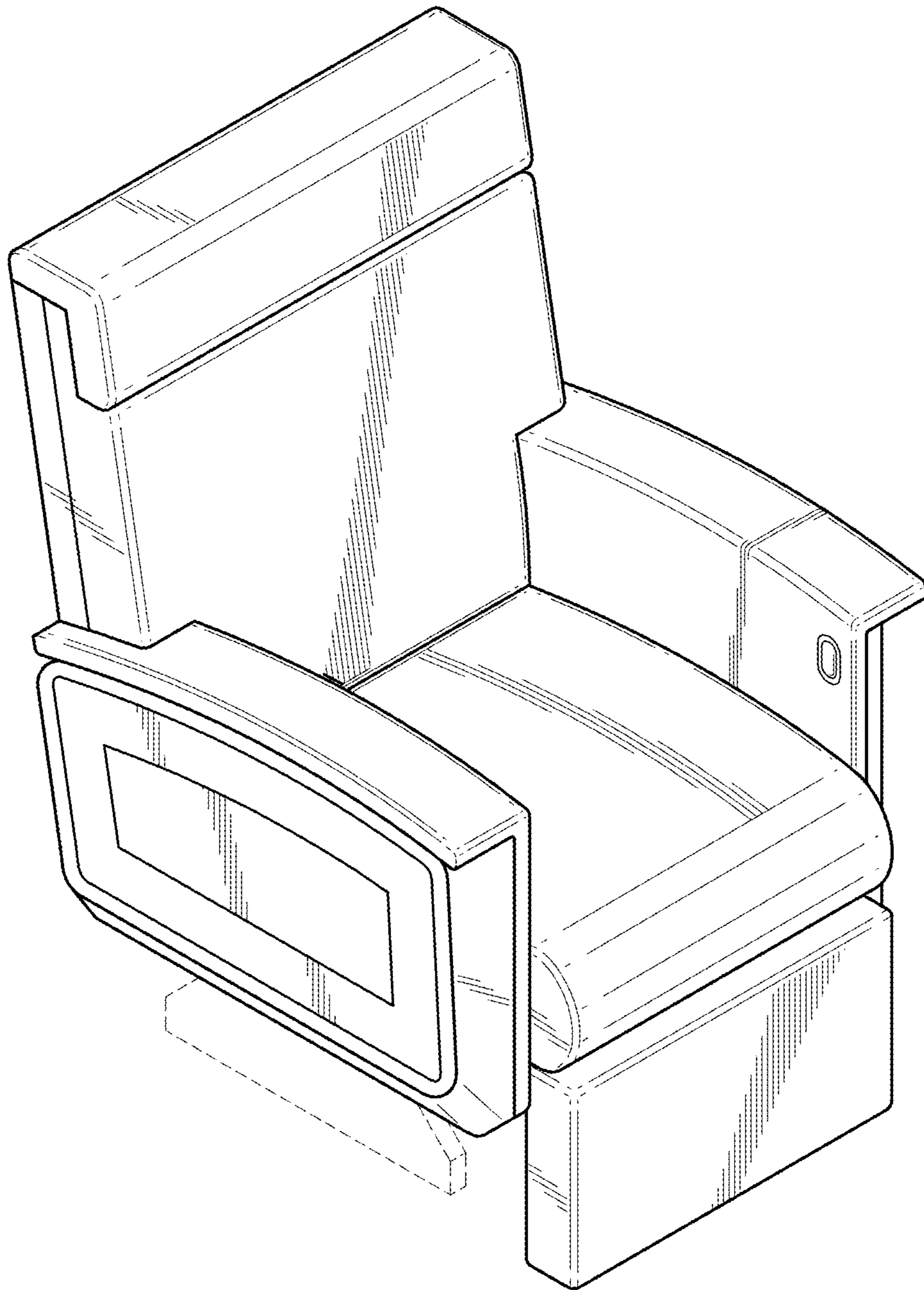

FIG. 9

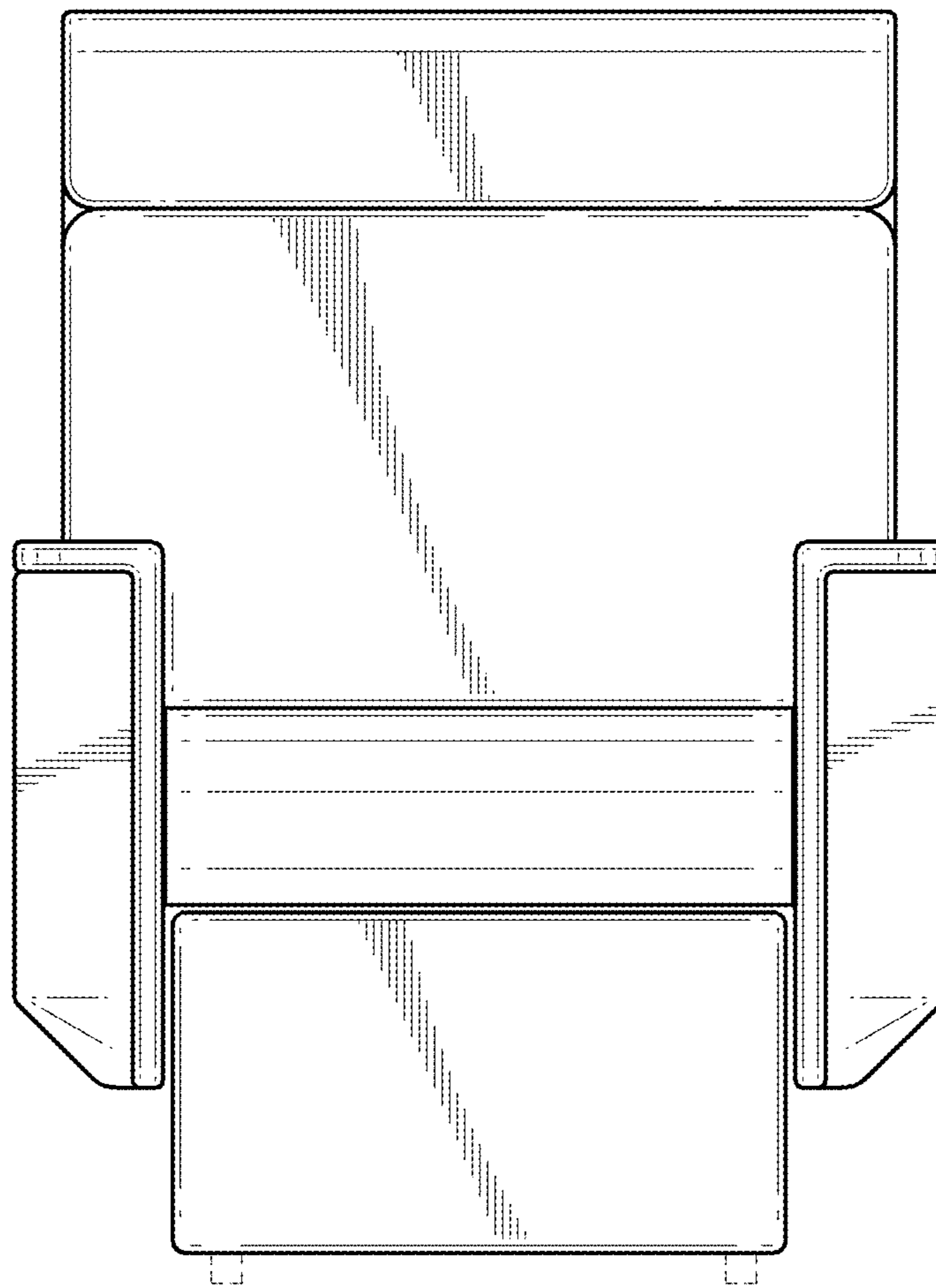

FIG. 10

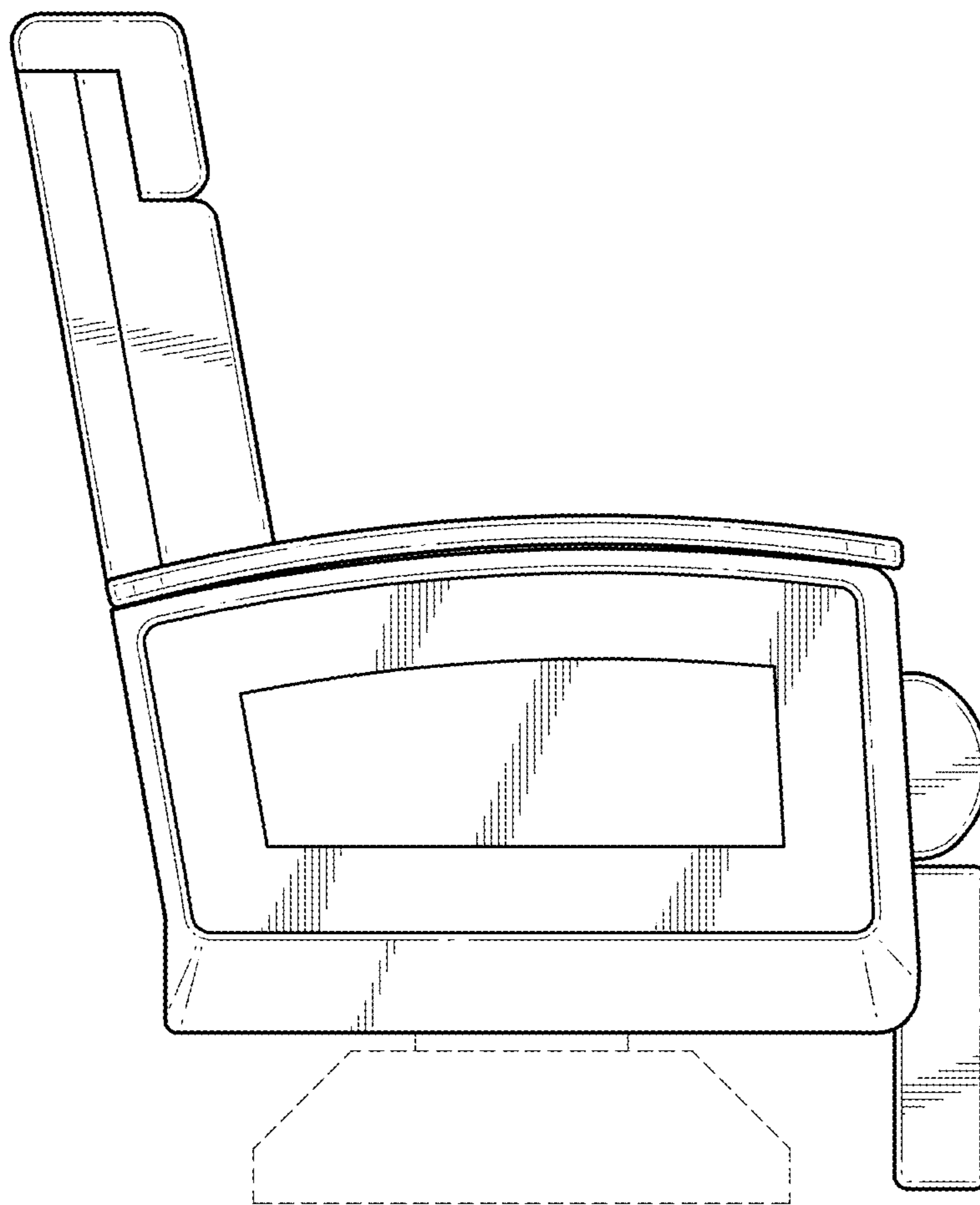

FIG. 11

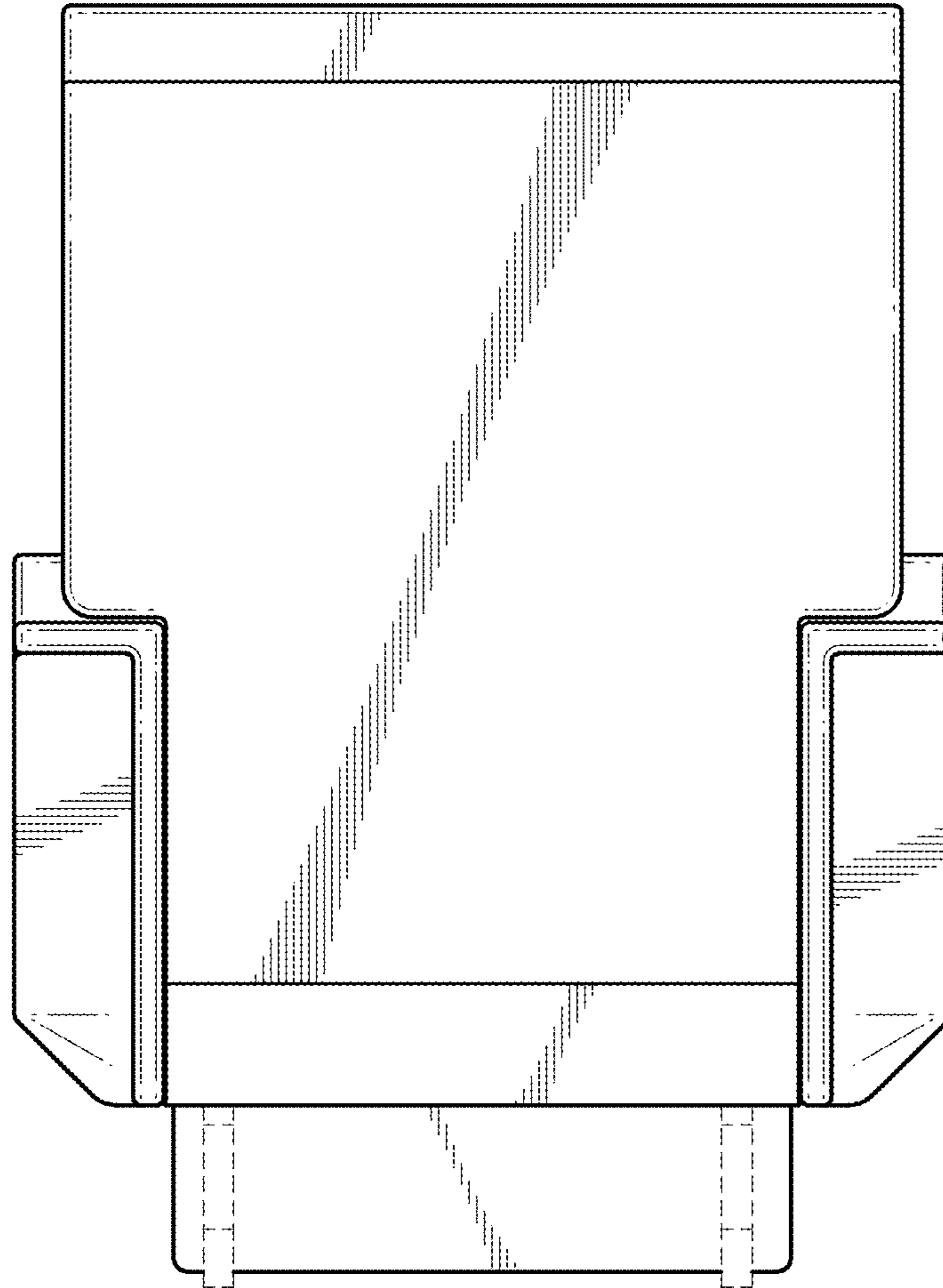

FIG. 12

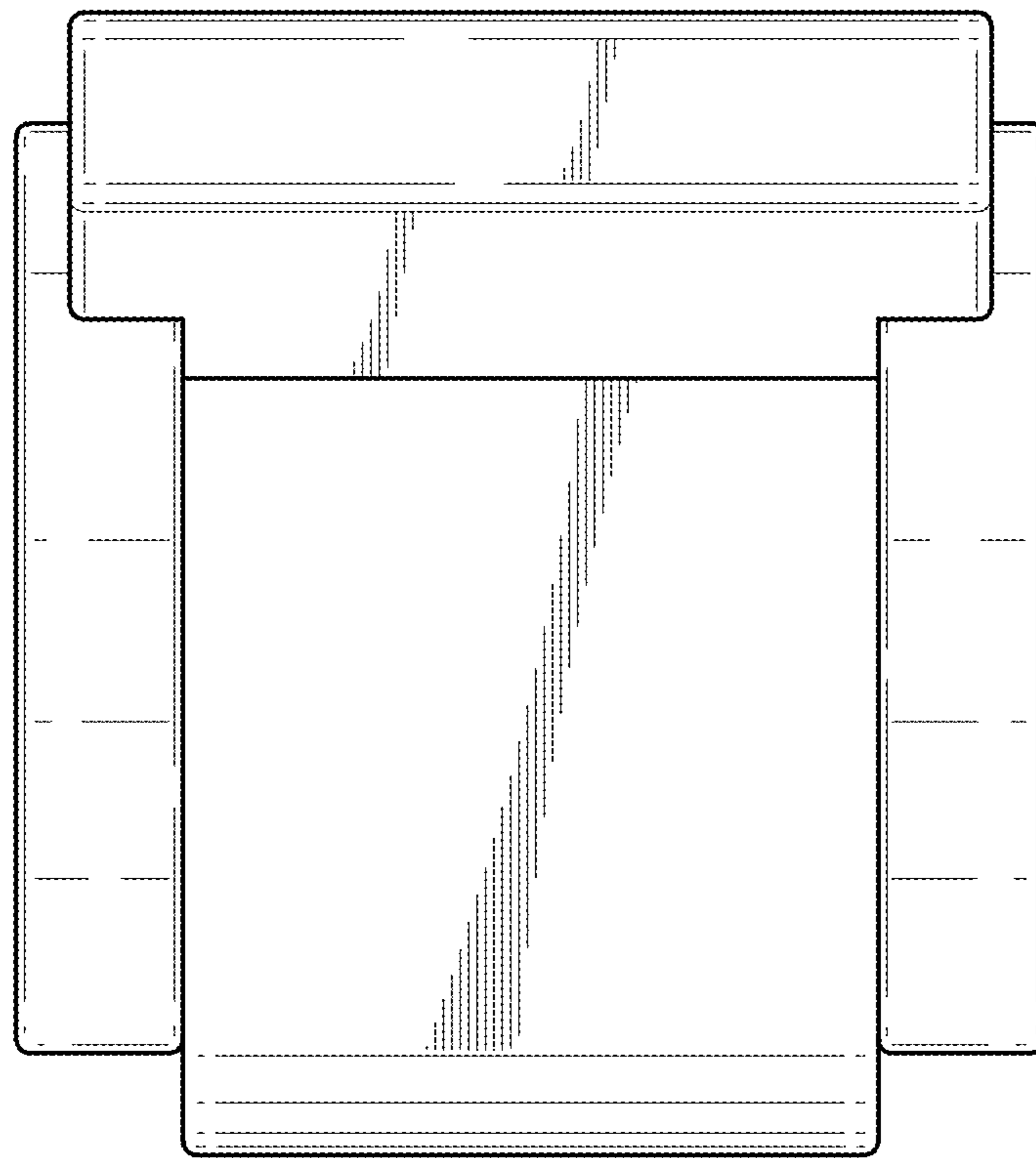

FIG. 13

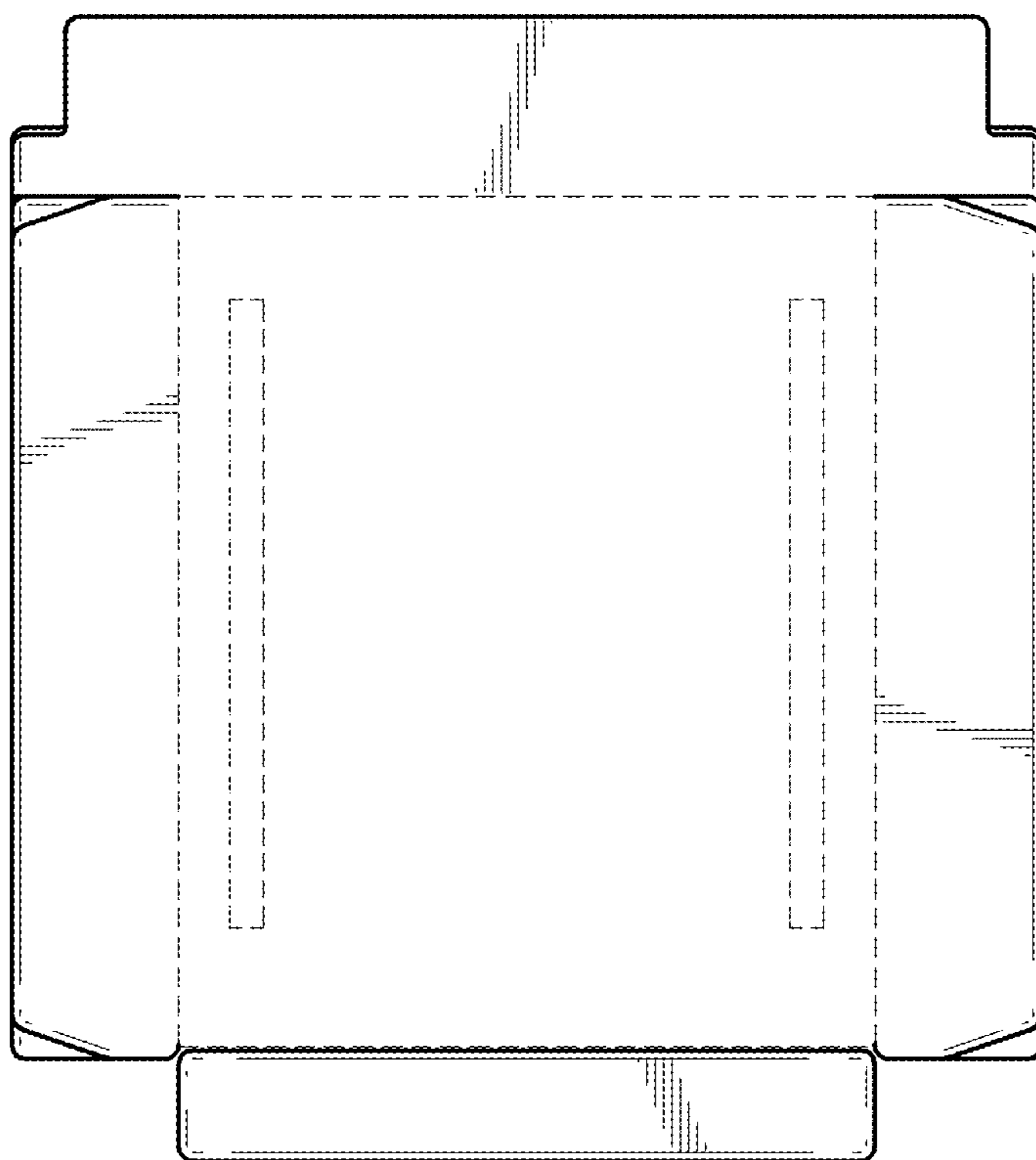

FIG. 14