



US00D800045S

(12) **United States Design Patent**
Taylor

(10) **Patent No.:** **US D800,045 S**

(45) **Date of Patent:** **** Oct. 17, 2017**

(54) **WHEEL**

(71) Applicant: **Fredrick Taylor**, Rome, GA (US)

(72) Inventor: **Fredrick Taylor**, Rome, GA (US)

(**) Term: **15 Years**

(21) Appl. No.: **29/558,377**

(22) Filed: **Mar. 17, 2016**

(51) **LOC (10) Cl.** **12-16**

(52) **U.S. Cl.**
USPC **D12/211**

(58) **Field of Classification Search**
USPC D12/204–213
CPC B60B 7/00; B60B 7/02; B60B 7/04; B60B
7/01; B60B 7/06; B60B 3/02; B60B 3/04;
B60B 3/06; B60B 3/10; B60B 1/00;
B60B 1/08; B60B 1/10; B60B 1/12
See application file for complete search history.

(56) **References Cited**

U.S. PATENT DOCUMENTS

D199,054 S	*	9/1964	Golata	D12/211
D204,933 S	*	5/1966	Richter	D12/211
D222,446 S	*	10/1971	Buerger	D12/211
D241,830 S	*	10/1976	Patch	D12/211
D259,484 S	*	6/1981	Welburn	D12/209

D414,154 S	*	9/1999	Carter	D12/209
D414,156 S	*	9/1999	Gilles	D12/211
D419,517 S	*	1/2000	Sacco	D12/211
D458,574 S	*	6/2002	Kaucher	D12/211
D535,933 S	*	1/2007	Markefka	D12/209
D554,034 S	*	10/2007	Madden	D12/209
D609,155 S	*	2/2010	Bucher	D12/209
D609,156 S	*	2/2010	Rider	D12/211
D609,622 S	*	2/2010	Rider	D12/209
D658,103 S	*	4/2012	Choe	D12/209
D713,312 S	*	9/2014	Villarruel	D12/209
D770,959 S	*	11/2016	Chung	D12/211
D772,131 S	*	11/2016	Wheel	D12/209
D775,578 S	*	1/2017	Johnson	D12/211

* cited by examiner

Primary Examiner — Stacia Cadmus

(74) *Attorney, Agent, or Firm* — Thomas | Horstemeyer, LLP

(57) **CLAIM**

The ornamental design for a wheel, as shown and described.

DESCRIPTION

FIG. 1 is a perspective view of a wheel, showing my new design; and,

FIG. 2 is a front view thereof.

The broken line showing of the rear portion of the wheel is included for the purpose of illustrating environment and forms no part of the claimed design.

1 Claim, 2 Drawing Sheets

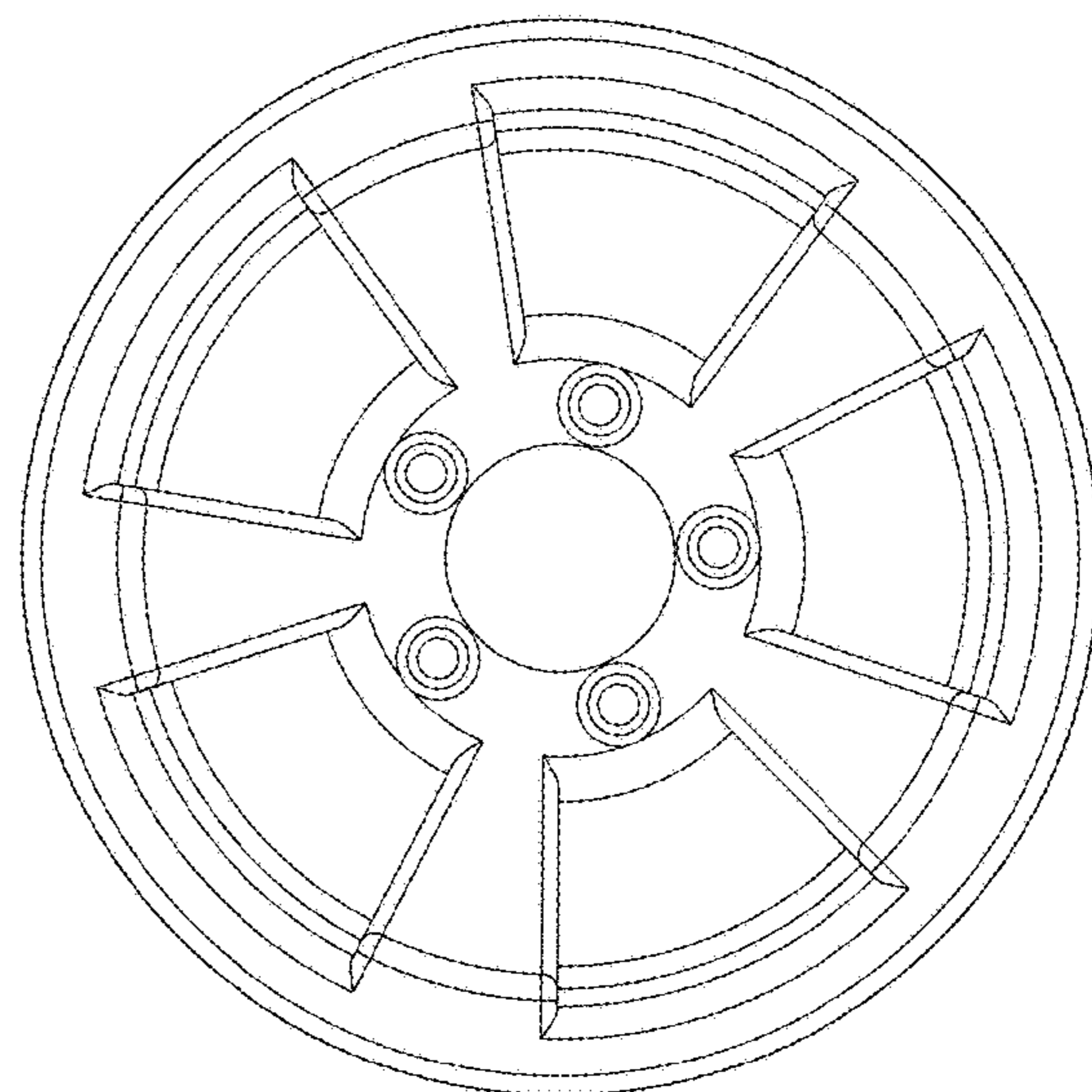
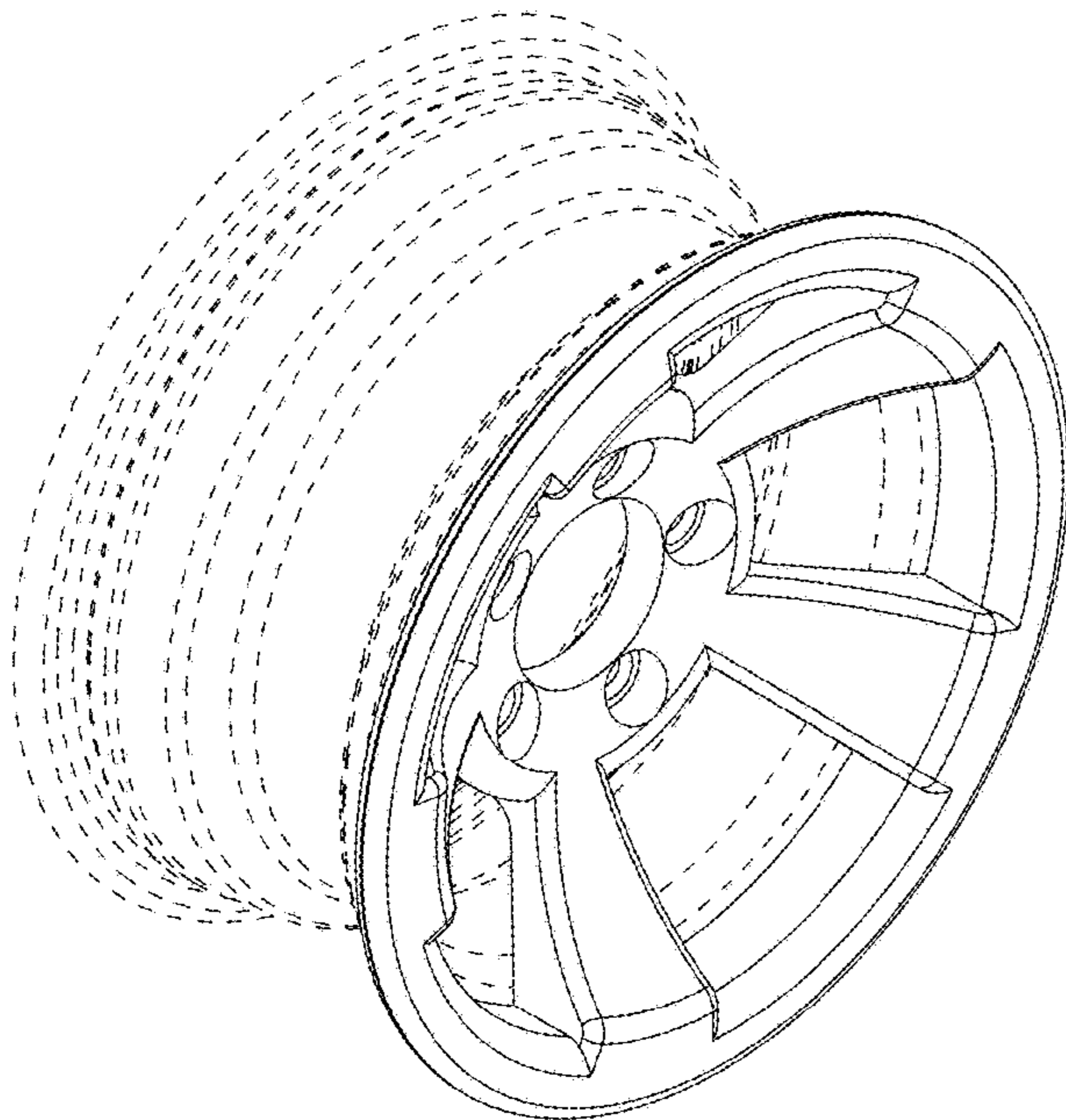

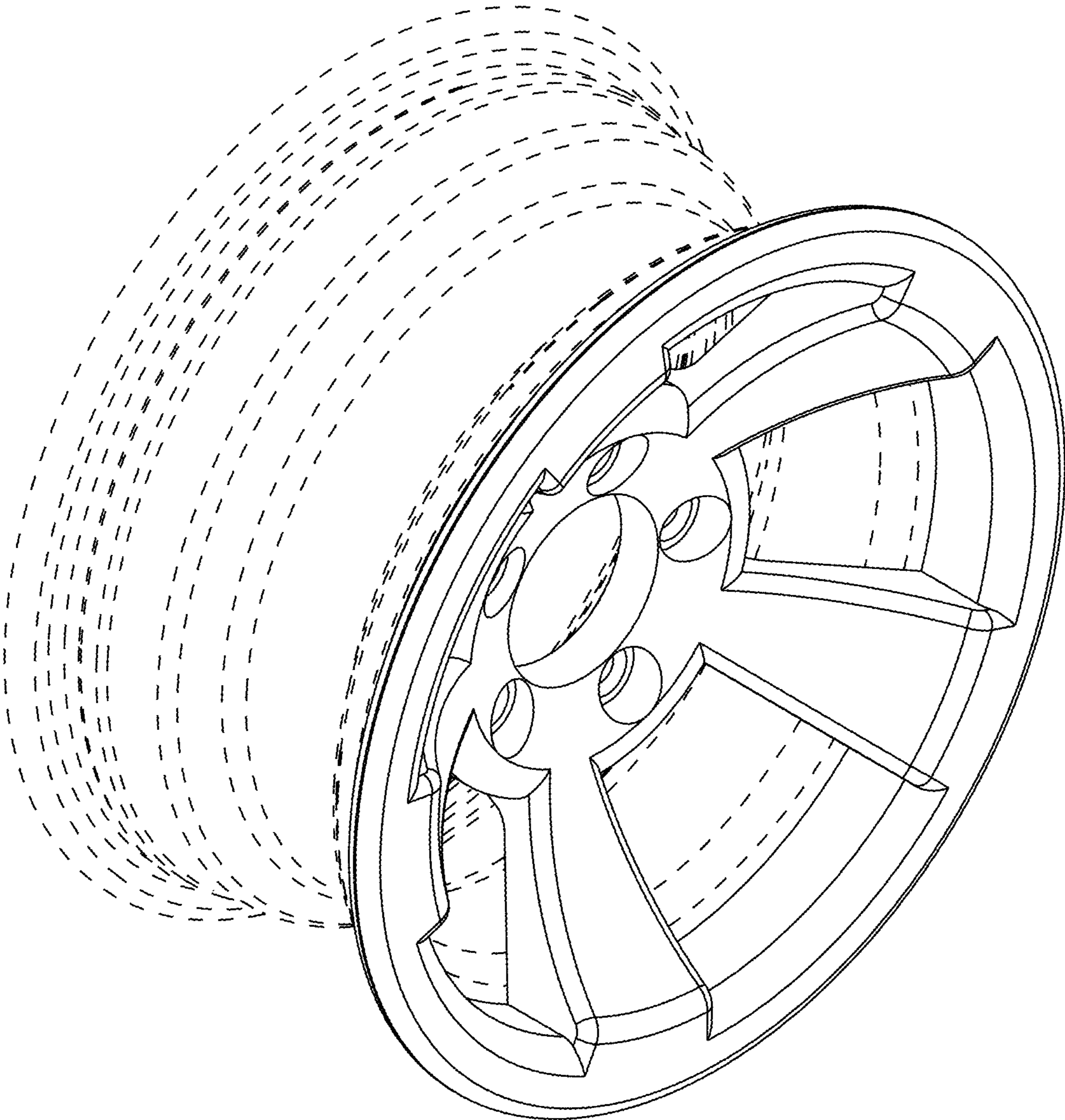

FIG. 1

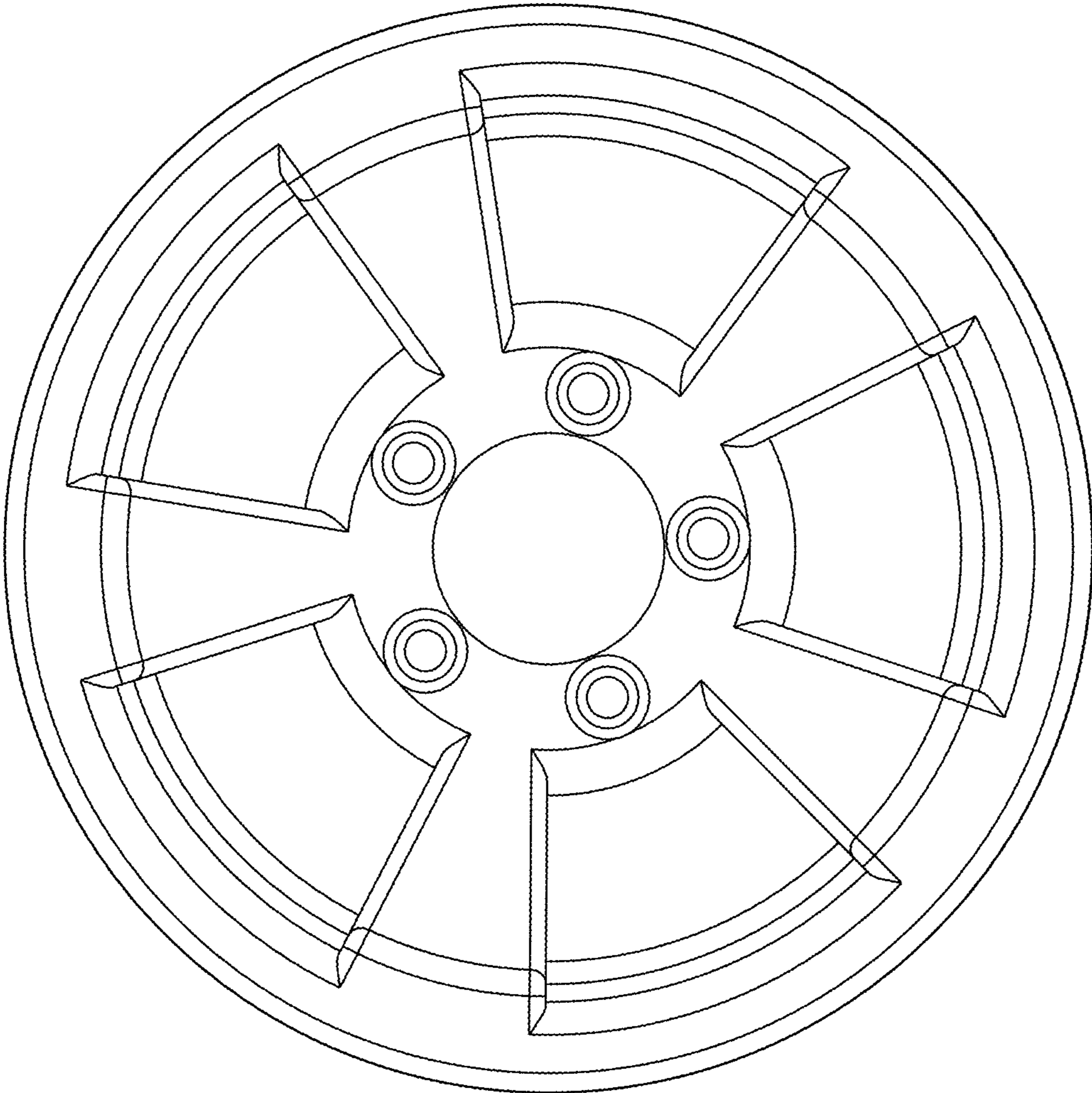

FIG. 2