

US00D800037S

(12) **United States Design Patent**
Kim et al.

(10) **Patent No.:** **US D800,037 S**

(45) **Date of Patent:** **** Oct. 17, 2017**

(54) **CAR INTERIOR**

(71) Applicant: **Faraday & Future Inc.**, Gardena, CA (US)

(72) Inventors: **Richard S. Kim**, Los Angeles, CA (US); **Taeho Kim**, Los Angeles, CA (US); **Joan Pontus Anthony Fontaeus**, Newport Beach, CA (US); **Claudio Carbone**, Los Angeles, CA (US); **Charles LeFranc**, Topenga, CA (US)

(73) Assignee: **FARADAY & FUTURE INC.**, Gardena, CA (US)

(**) Term: **15 Years**

(21) Appl. No.: **29/550,093**

(22) Filed: **Dec. 30, 2015**

(51) **LOC (10) Cl.** **12-16**

(52) **U.S. Cl.**
USPC **D12/187**

(58) **Field of Classification Search**
USPC D12/195, 193, 414, 190, 196; D15/17, D15/28; D10/46, 98, 102-103; D8/302-303
CPC B60R 13/02; B60R 13/0243; B60J 5/04; B60N 2/466; B60N 2/4693
See application file for complete search history.

(56) **References Cited**

U.S. PATENT DOCUMENTS

D554,033 S * 10/2007 Hill D12/192
D577,644 S * 9/2008 Wyszogrod D12/192

D630,987 S * 1/2011 Edwards D12/195
D632,237 S * 2/2011 Green D12/195
D666,544 S * 9/2012 Tsay D12/195
D673,488 S * 1/2013 Balko D12/195
D693,754 S * 11/2013 Balko D12/195
D719,883 S * 12/2014 Palma D12/195
2002/0158448 A1 * 10/2002 Okonkwo B60K 37/00 280/728.2

* cited by examiner

Primary Examiner — Karina A Betton

(74) *Attorney, Agent, or Firm* — Knobbe, Martens, Olson & Bear LLP

(57) **CLAIM**

The ornamental design for an interior for a car, including toy-car, motor car, replica car, scale-model-car, and/or other replicas, as shown and described.

DESCRIPTION

FIG. 1 is a top, front, and left side perspective view of a first embodiment of an interior for a car, including toy-car, motor car, replica car, scale-model-car, and/or other replicas.

FIG. 2 is a top, rear, and right side perspective view of the interior of FIG. 1.

FIG. 3 is a front elevation view of the interior of FIG. 1.

FIG. 4 is a rear elevation view of the interior of FIG. 1.

FIG. 5 is a left side elevation view of the interior of FIG. 1.

FIG. 6 is a right side elevation view of the interior of FIG. 1.

FIG. 7 is a top plan view of the interior of FIG. 1; and,

FIG. 8 is a bottom plan view of the interior of FIG. 1.

The broken lines in the drawings depict environmental structure and form no part of the claimed design.

1 Claim, 7 Drawing Sheets

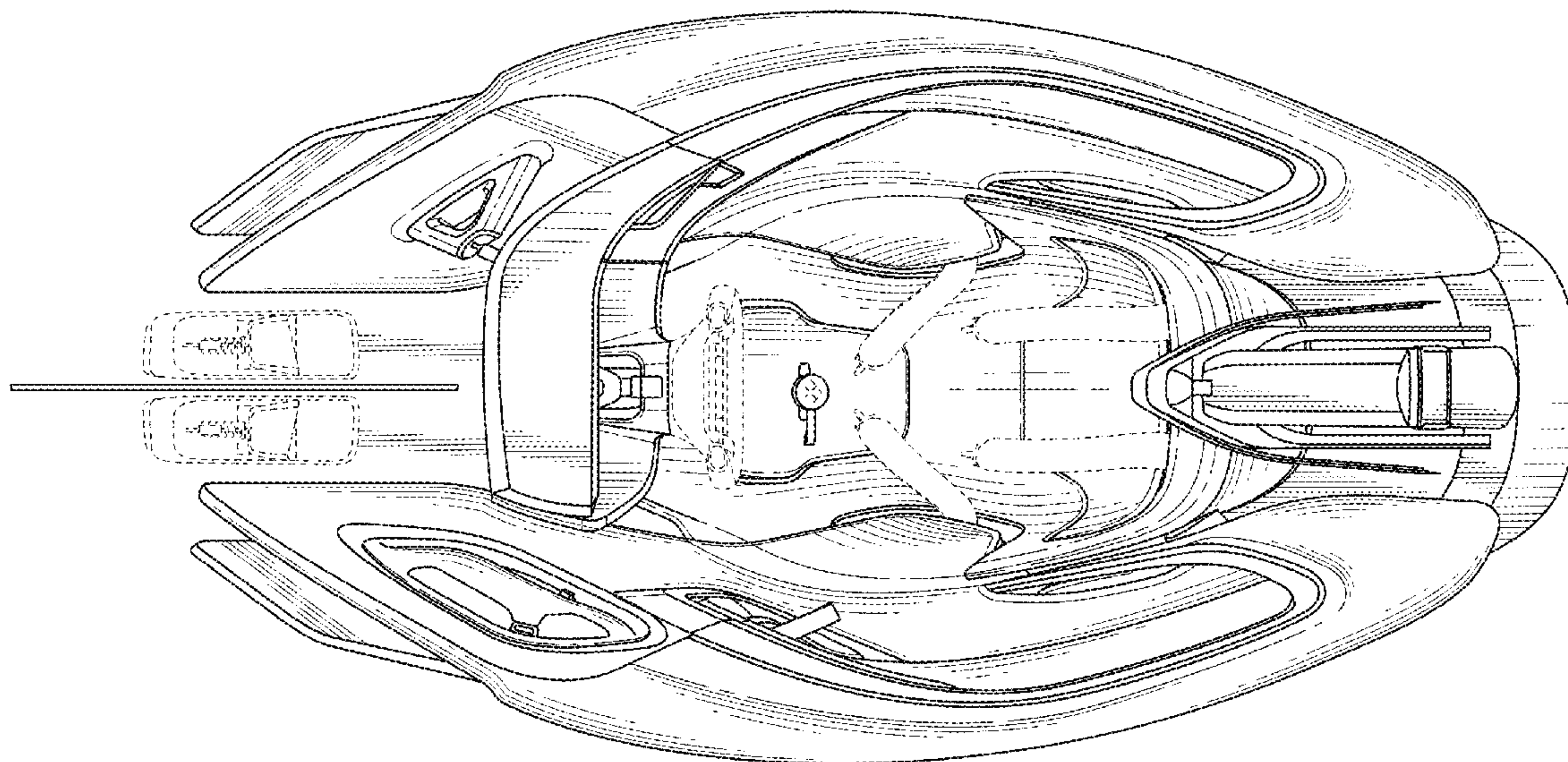

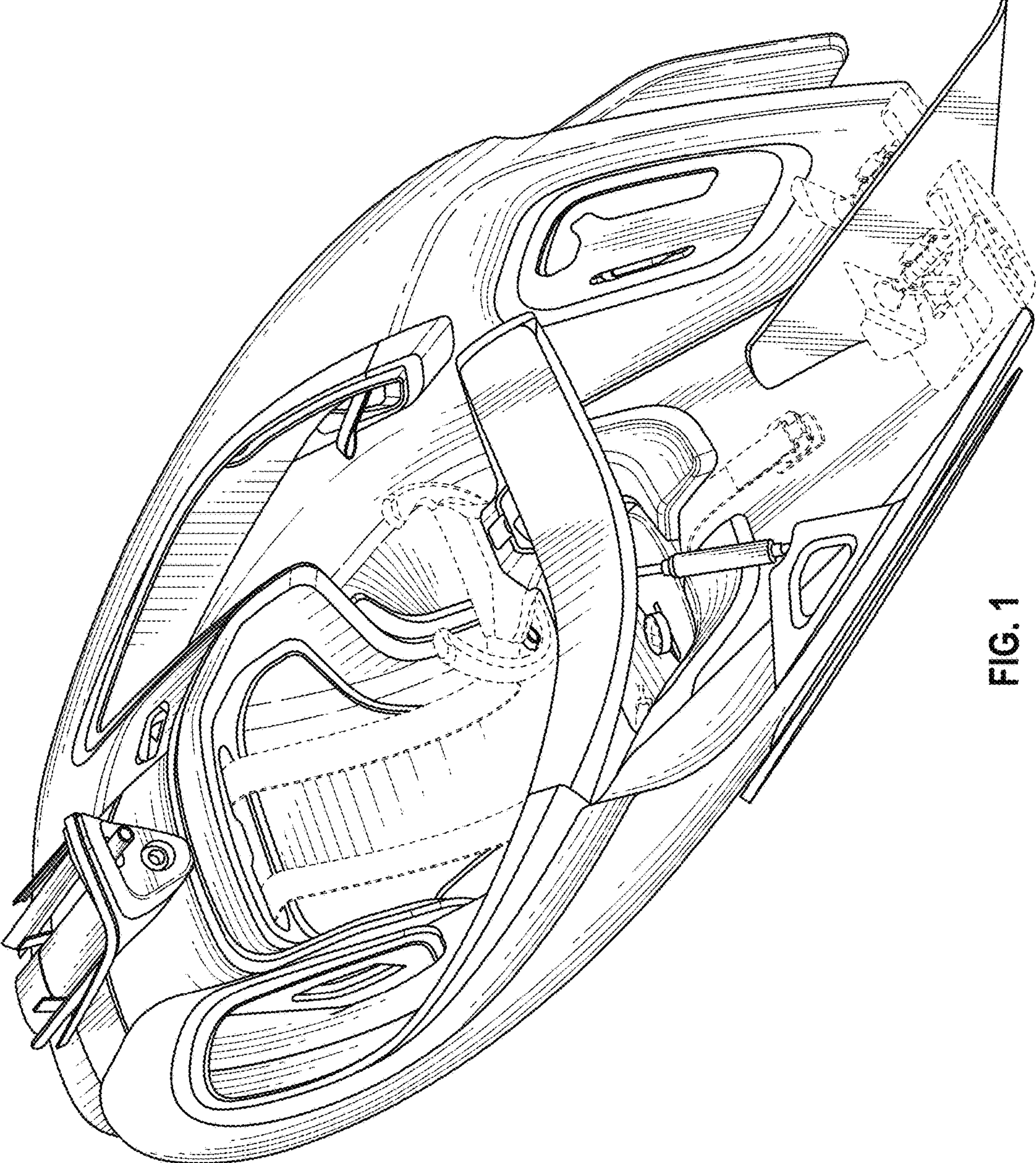

FIG. 1

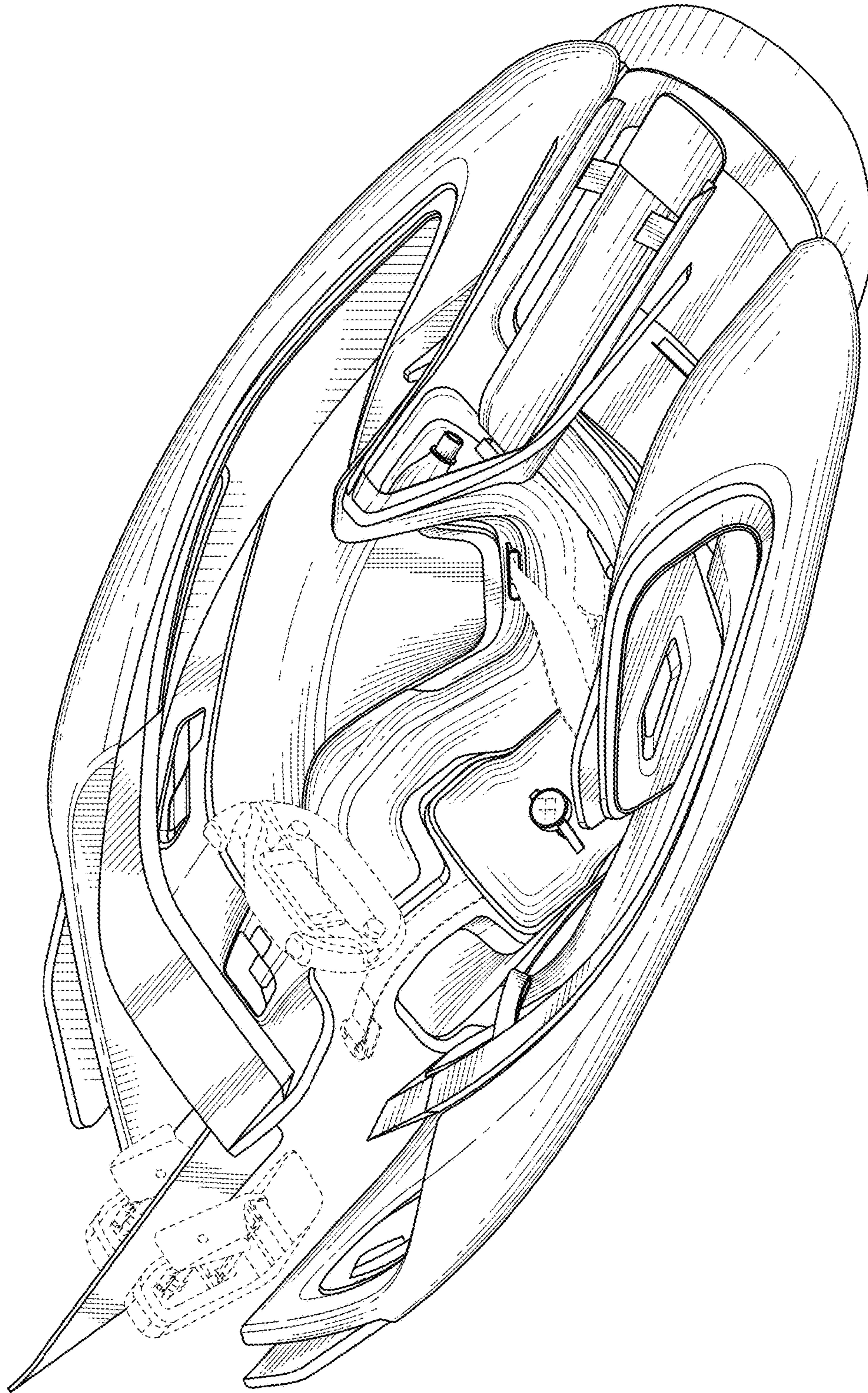

FIG. 2

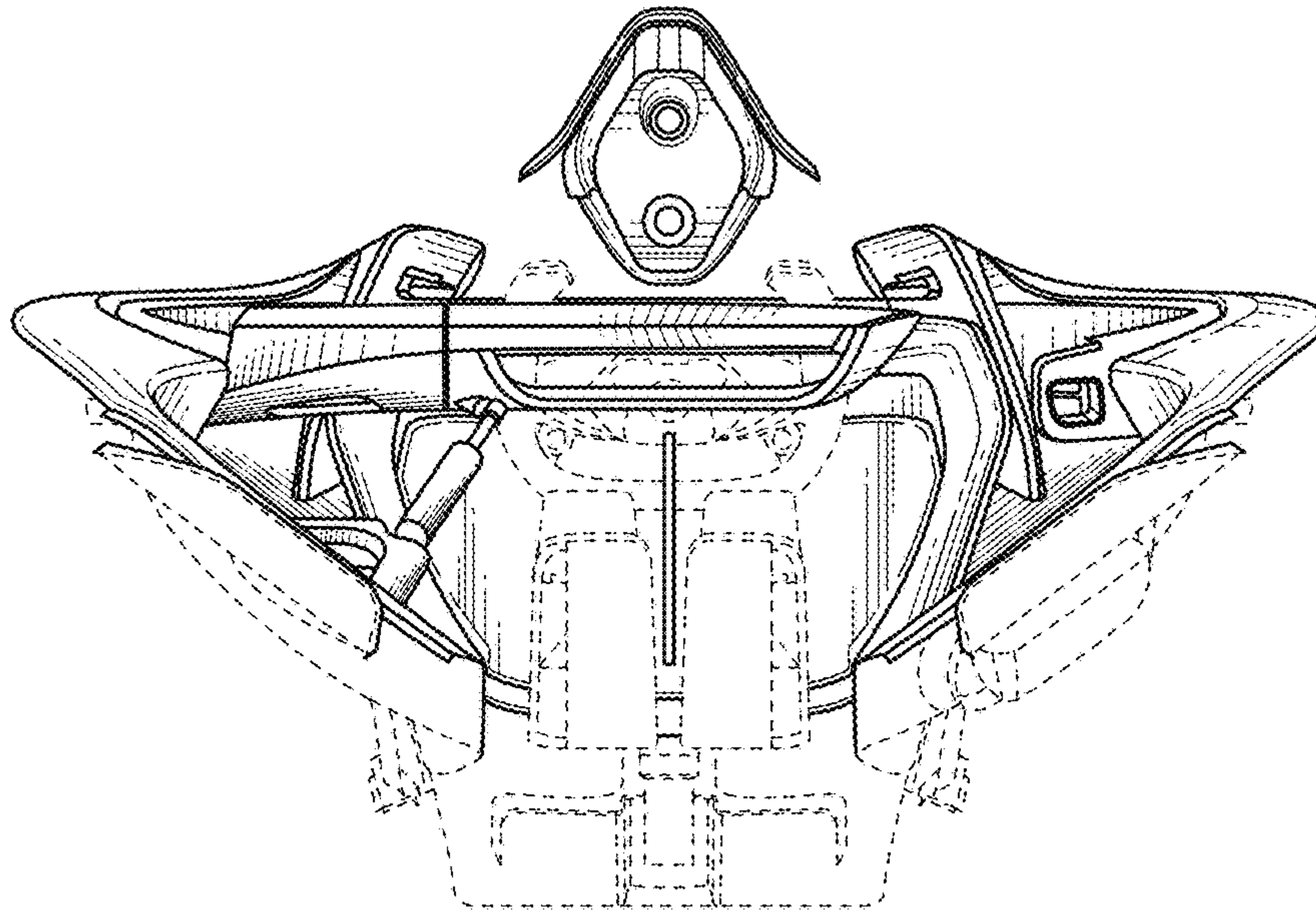

FIG. 3

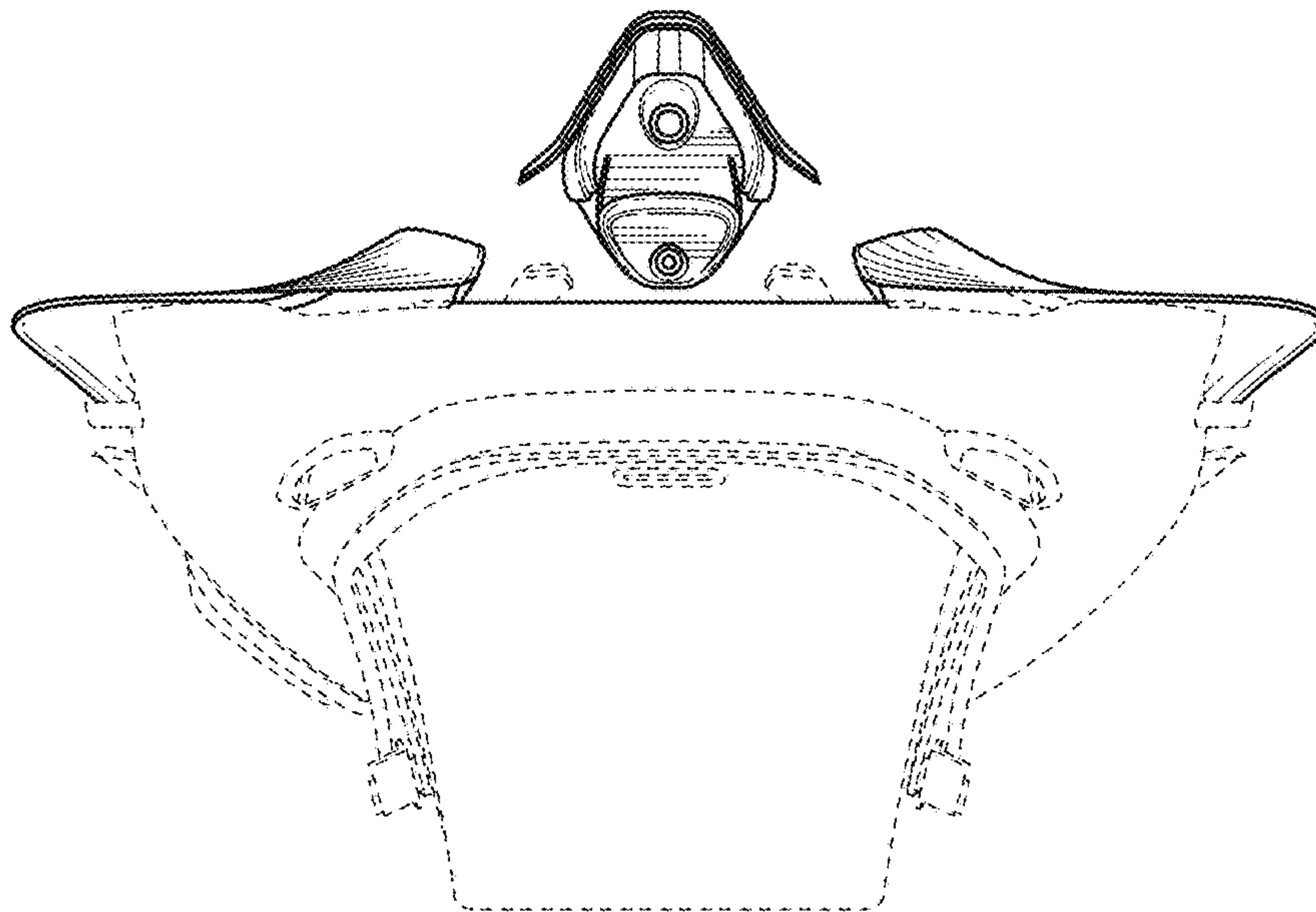

FIG. 4

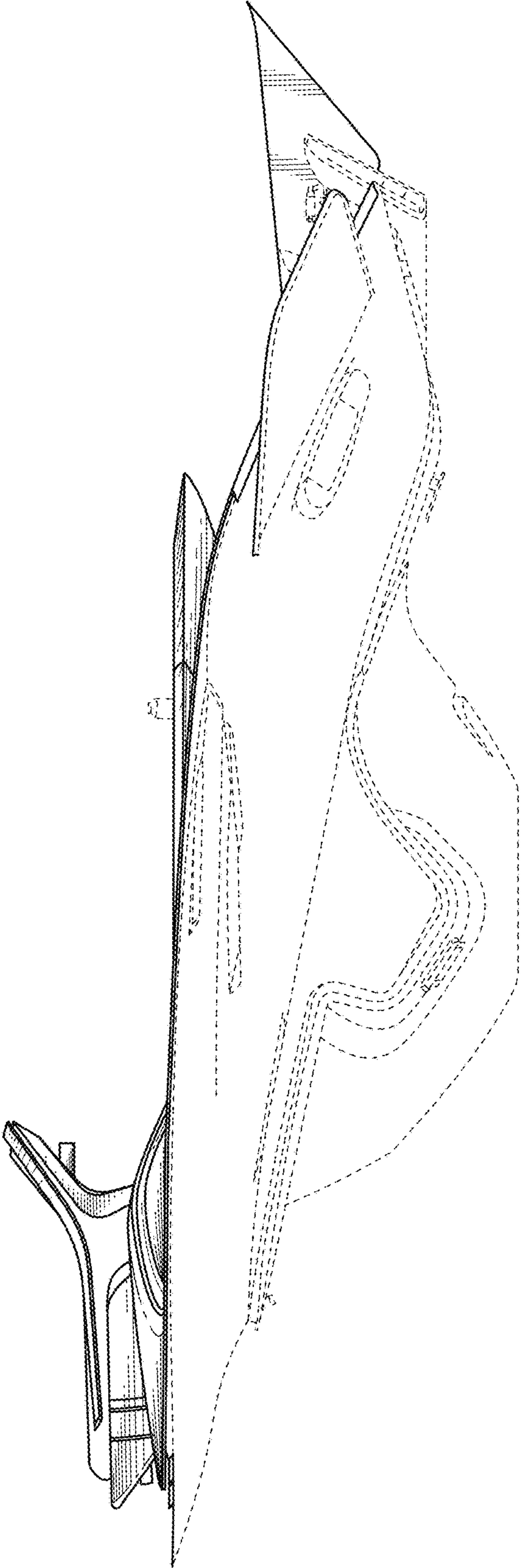

FIG. 5

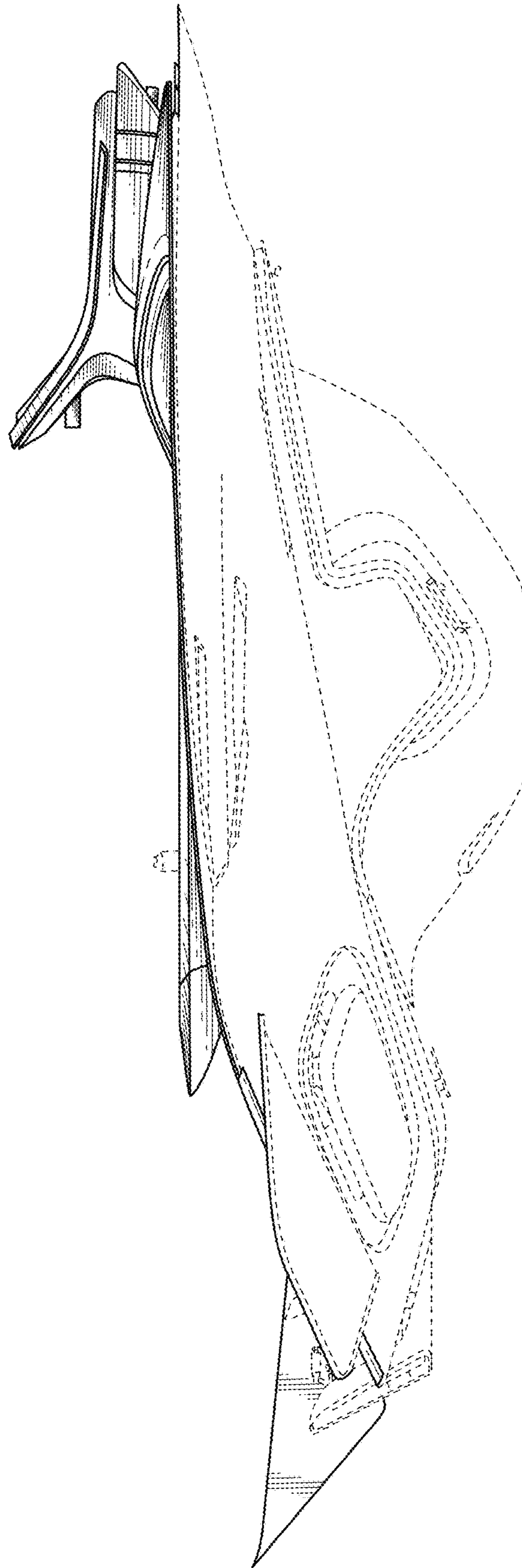

FIG. 6

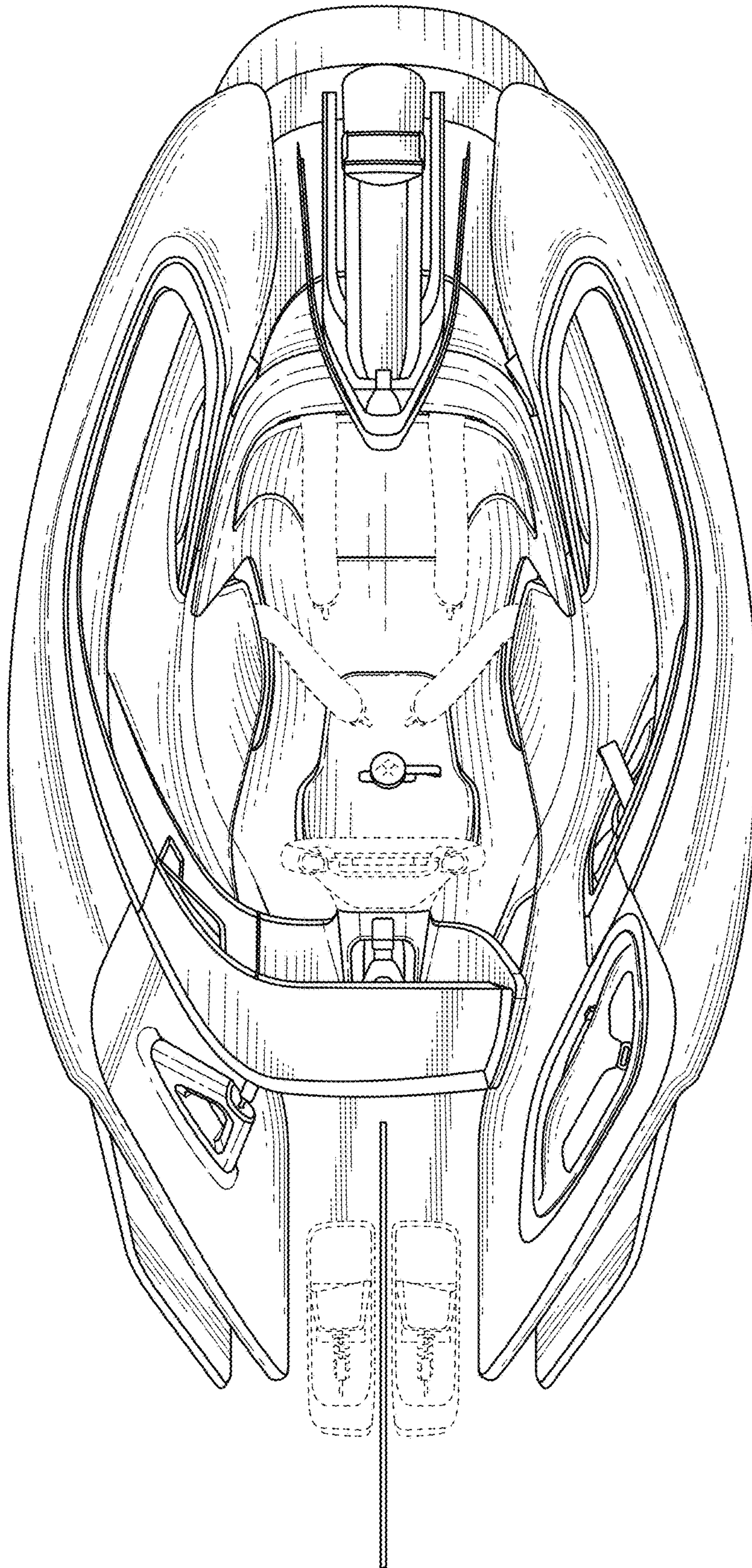

FIG. 7

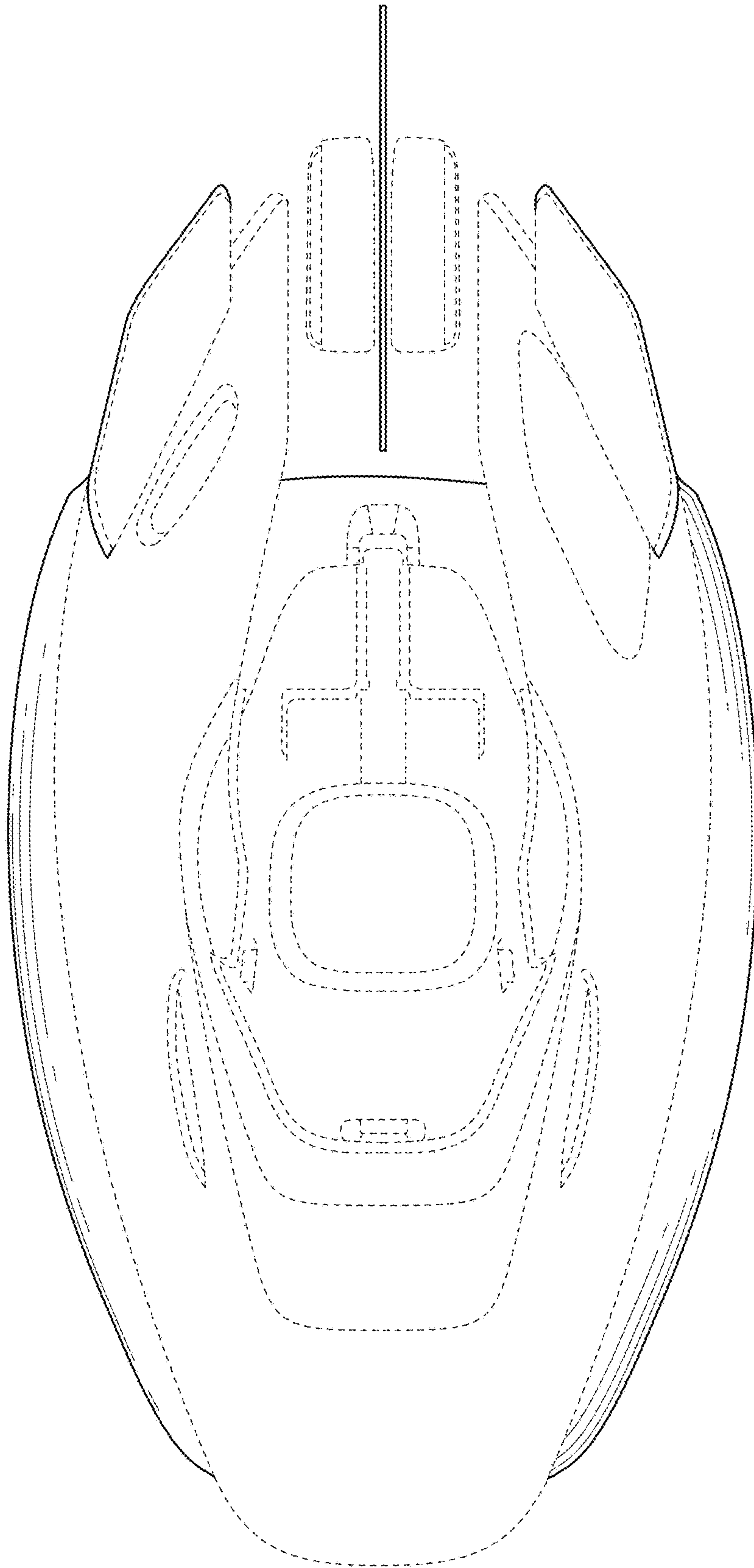

FIG. 8