



US00D800024S

(12) **United States Design Patent**
Vital Huici

(10) **Patent No.:** **US D800,024 S**

(45) **Date of Patent:** **** Oct. 17, 2017**

(54) **BICYCLE FRAME**

(71) Applicant: **Ride On Consulting, S.L.**, Madrid (ES)

(72) Inventor: **Miguel Vital Huici**, Navarra (ES)

(73) Assignee: **Ride On Consulting, S.L.** (ES)

(**) Term: **15 Years**

(21) Appl. No.: **29/538,761**

(22) Filed: **Sep. 8, 2015**

(30) **Foreign Application Priority Data**

Jun. 12, 2015 (EM) 002717777-0001

(51) **LOC (10) Cl.** **12-11**

(52) **U.S. Cl.**
USPC **D12/111**

(58) **Field of Classification Search**
USPC D12/111, 117; 280/274–280, 281.1,
280/283–288, 288.1–288.4
CPC B62K 3/00; B62K 3/02; B62K 3/06
See application file for complete search history.

(56) **References Cited**

U.S. PATENT DOCUMENTS

D243,165 S *	1/1977	Wheeler	D12/111
D244,593 S *	6/1977	Manofsky	D12/111
D418,778 S *	1/2000	Allen	D12/111
D419,110 S *	1/2000	Allen	D12/111
D503,662 S *	4/2005	Tiyawatchalapong	D12/111
D606,908 S *	12/2009	Grimaldi	D12/111
D635,894 S *	4/2011	Argote Vivar	D12/111
D667,347 S *	9/2012	Simko	D12/111
D688,599 S *	8/2013	Silva	D12/111

D692,801 S *	11/2013	Lumpkin	D12/117
D721,014 S *	1/2015	Kahler, Jr.	D12/111
D722,285 S *	2/2015	Silva	D12/111
D724,498 S *	3/2015	Eagleman	D12/111
D738,261 S *	9/2015	Silva	D12/111
D759,549 S *	6/2016	Edmonds	D12/111
9,371,105 B2 *	6/2016	Chou	B62K 3/02

* cited by examiner

Primary Examiner — Darlington Ly

(74) *Attorney, Agent, or Firm* — Hayes Soloway PC

(57) **CLAIM**

The ornamental design for a bicycle frame, as shown and described.

DESCRIPTION

FIG. 1 is a left-side elevation view of a bicycle frame showing my new design;
 FIG. 2 is a right-side elevation view thereof;
 FIG. 3 is a bottom plan view thereof;
 FIG. 4 is a top plan view thereof;
 FIG. 5 is a rear elevation view thereof;
 FIG. 6 is a front elevation view thereof;
 FIG. 7 is a top, rear, and right-side perspective view thereof;
 FIG. 8 is a top and right-side perspective view thereof;
 FIG. 9 is a top, rear, and left-side perspective view thereof;
 FIG. 10 is a partial-enlarged top, rear, and left-side perspective view thereof;
 FIG. 11 is a bottom, front, and left-side perspective view thereof; and,
 FIG. 12 is a top, front, and left-side perspective view thereof.
 In FIG. 10, the phantom broken lines of dash-dot form illustrate a symbolic frame for the portions of the bicycle frame that have been enlarged. The phantom broken lines do not form part of the claimed design.

1 Claim, 12 Drawing Sheets

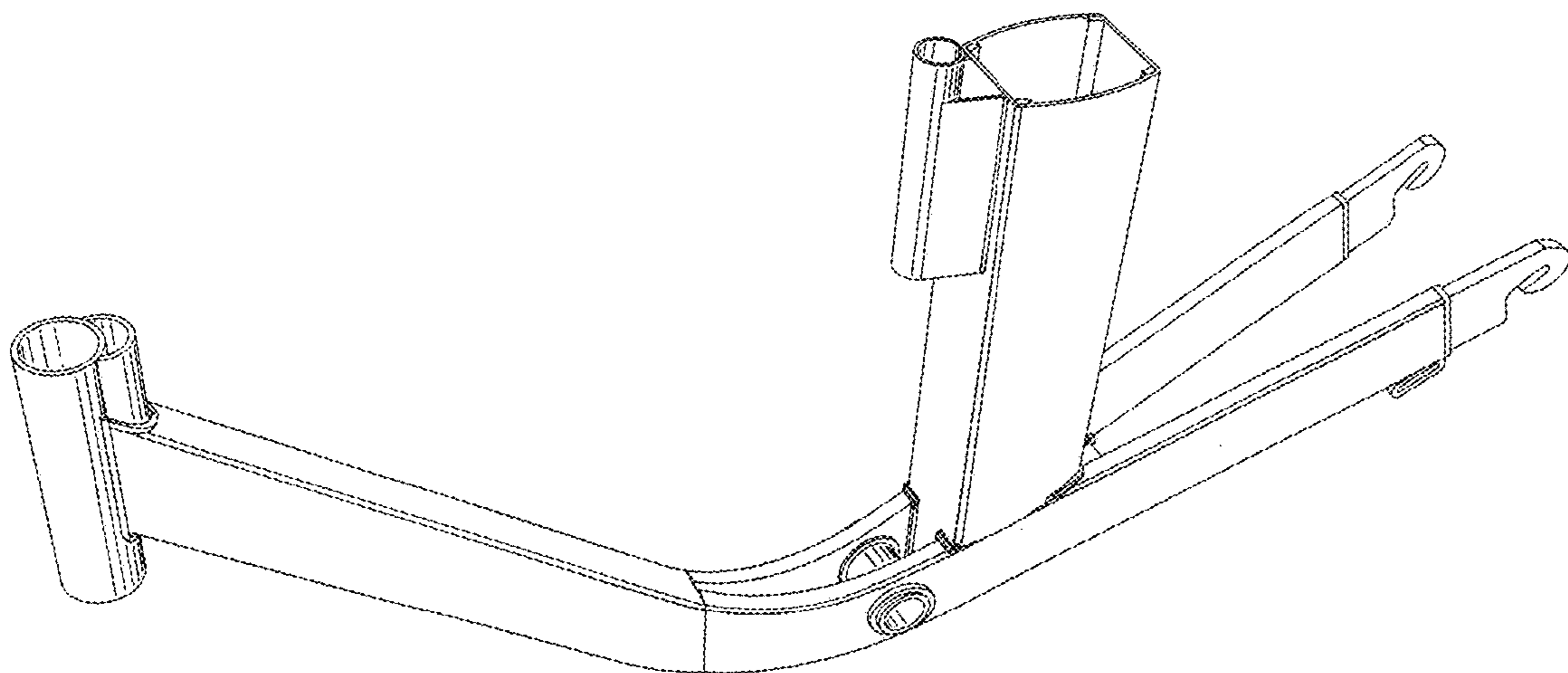

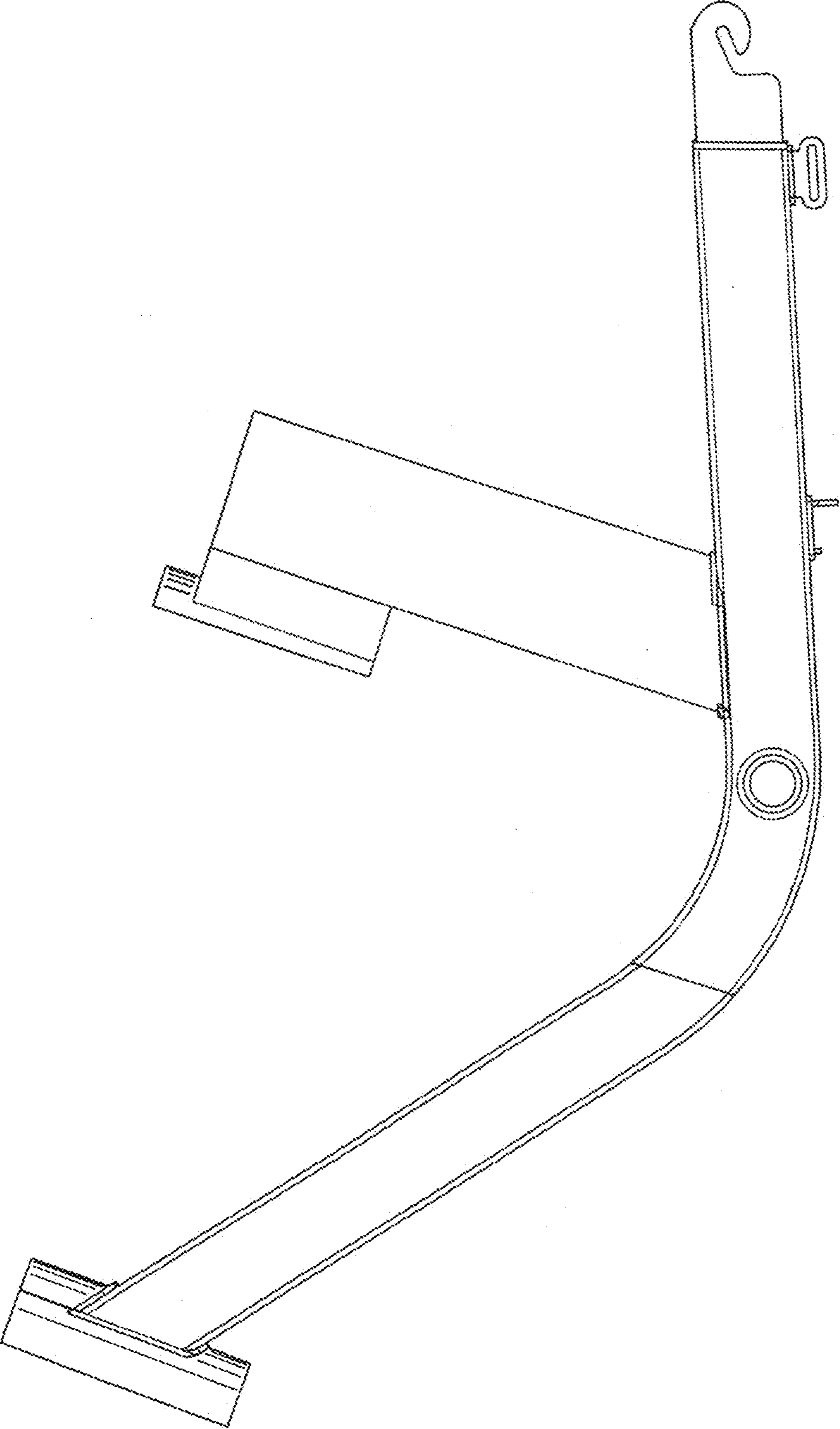

FIG. 1

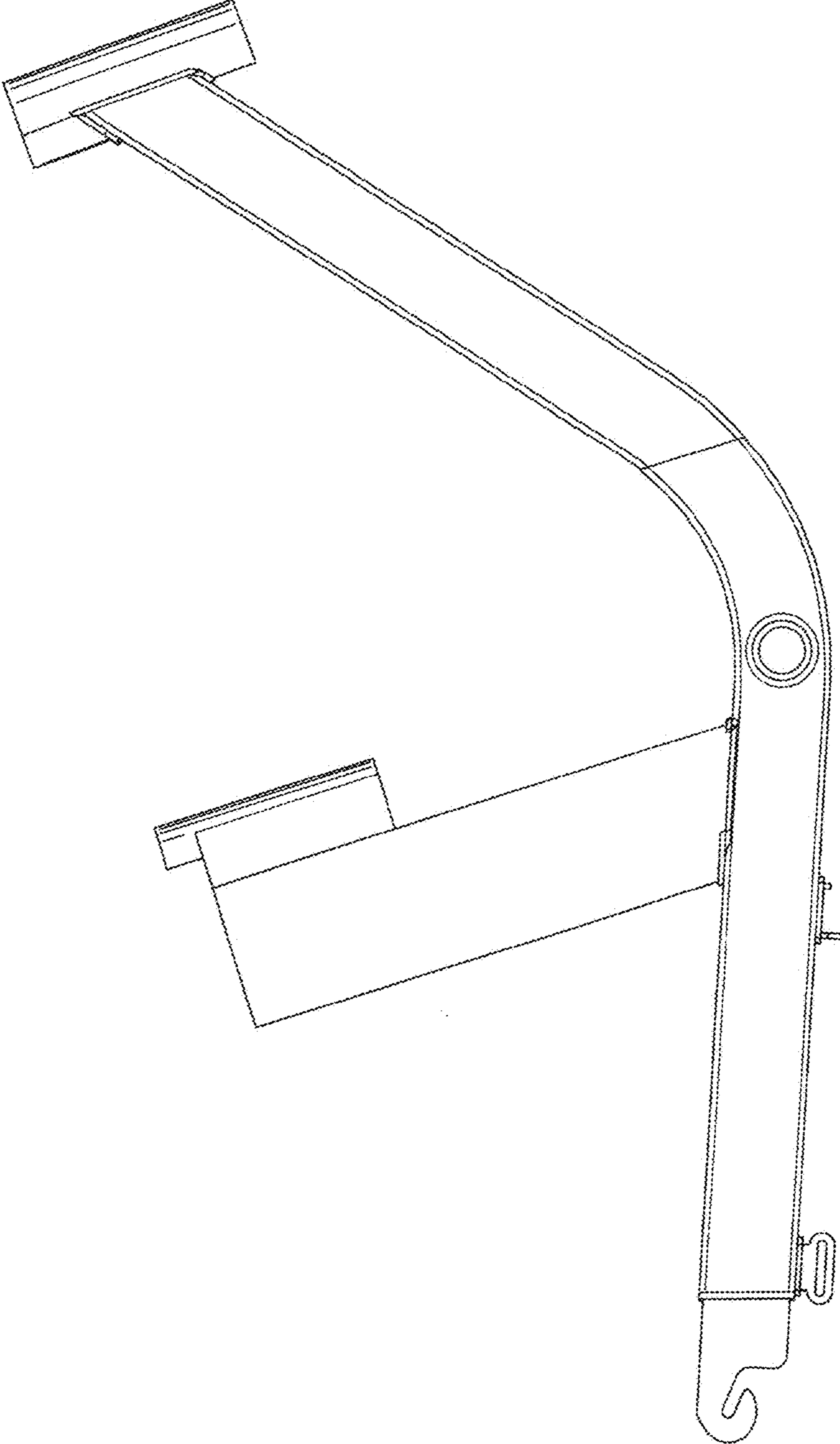

FIG. 2

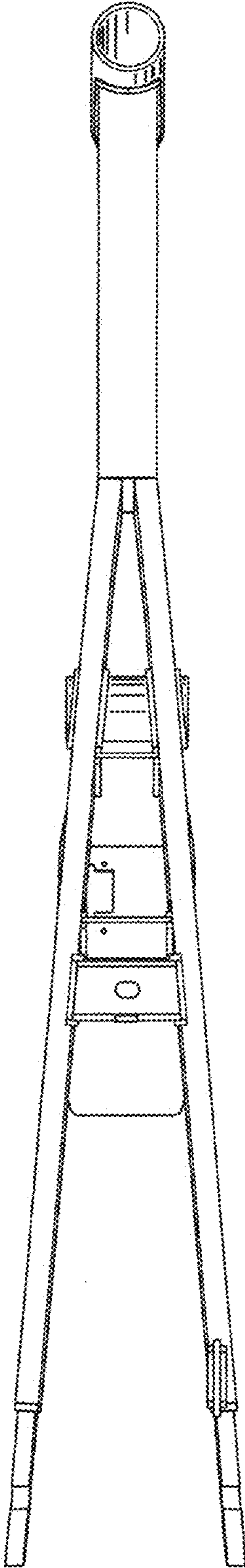

FIG. 3

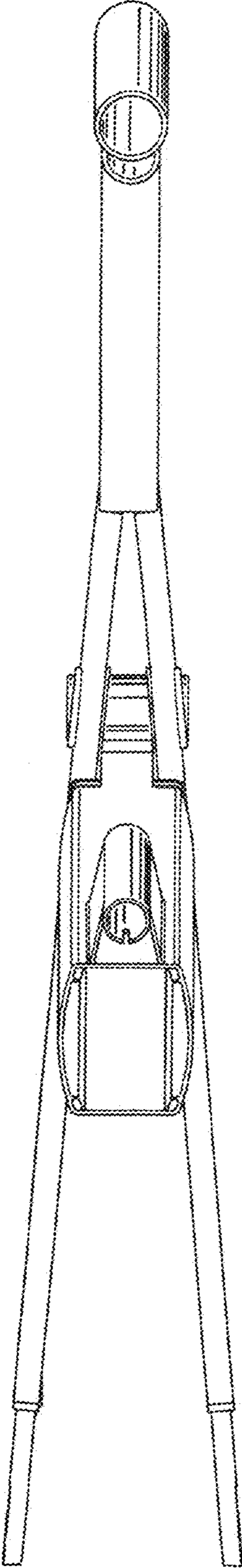

FIG. 4

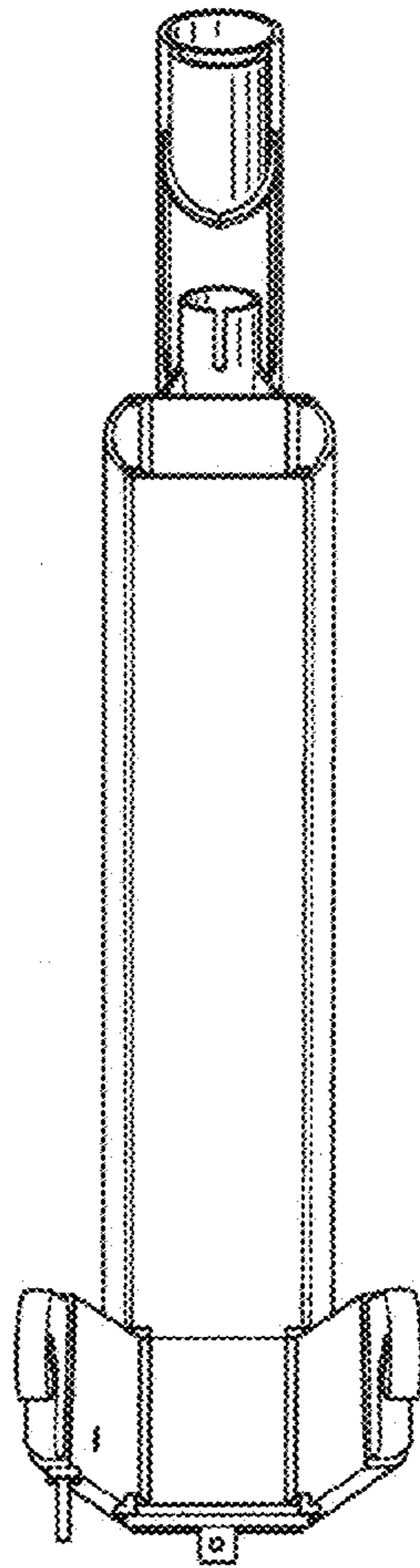

FIG. 5

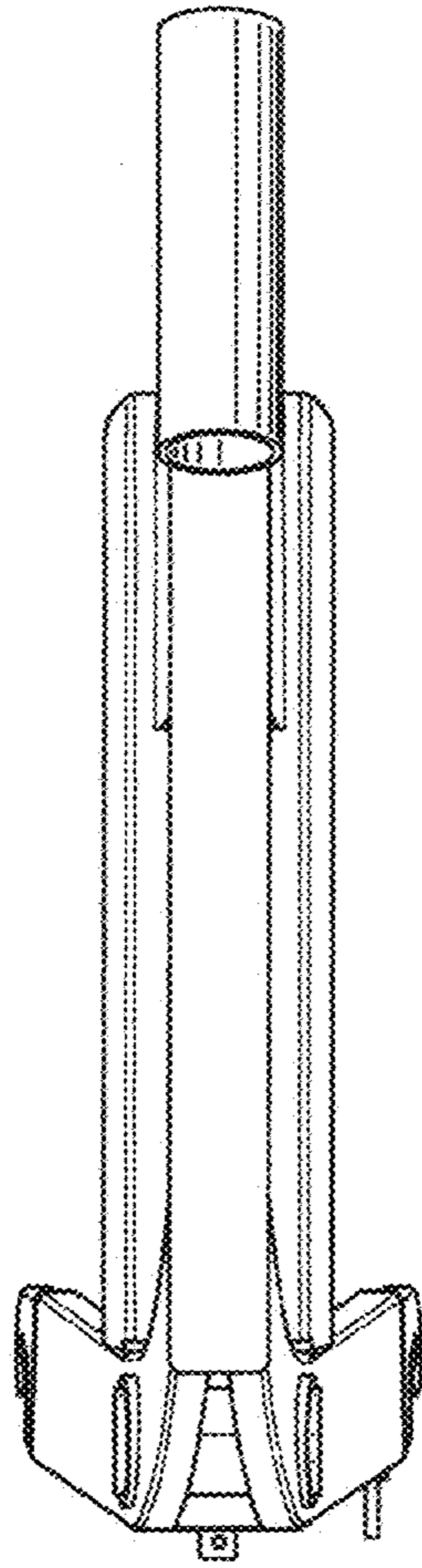

FIG. 6

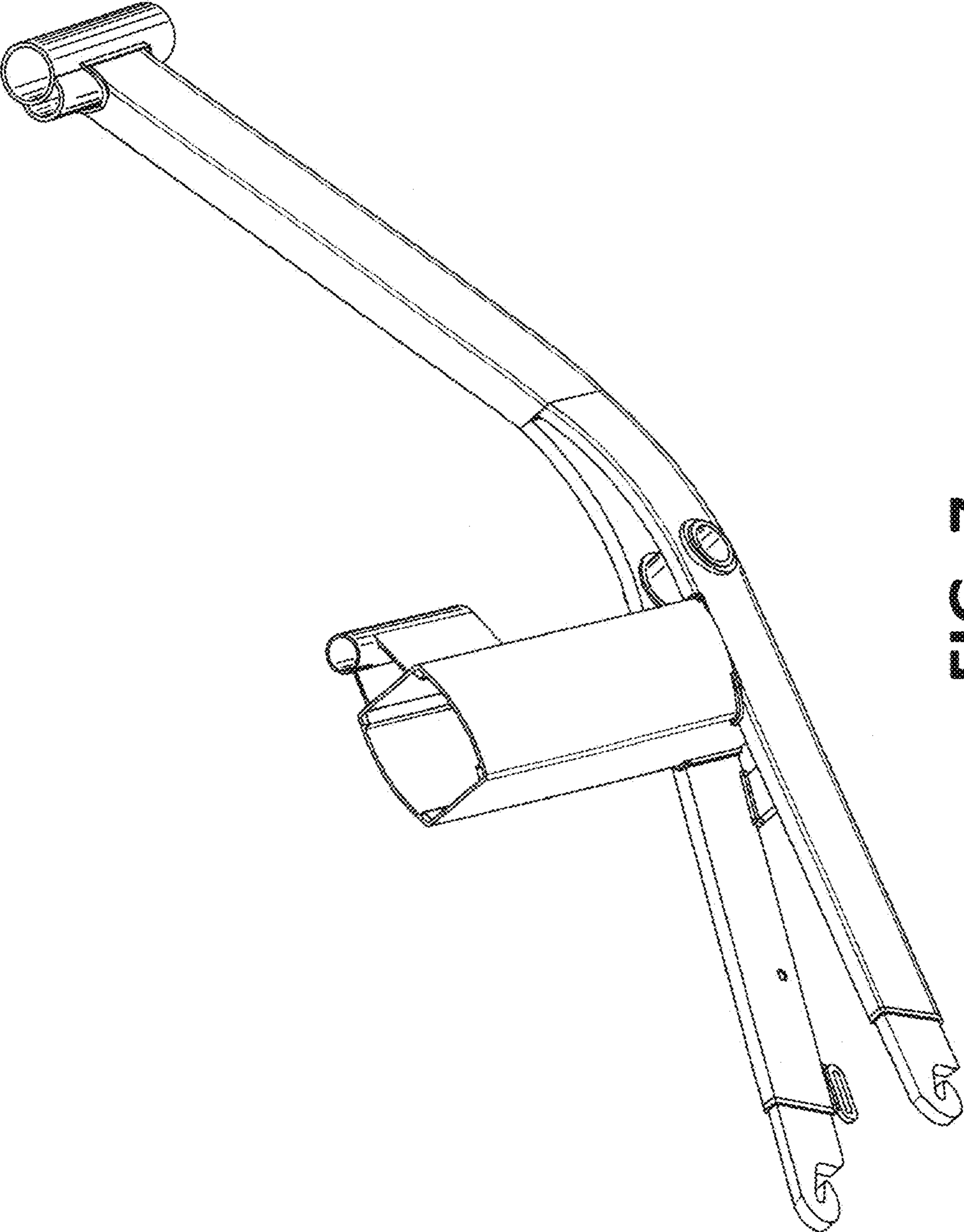

FIG. 7

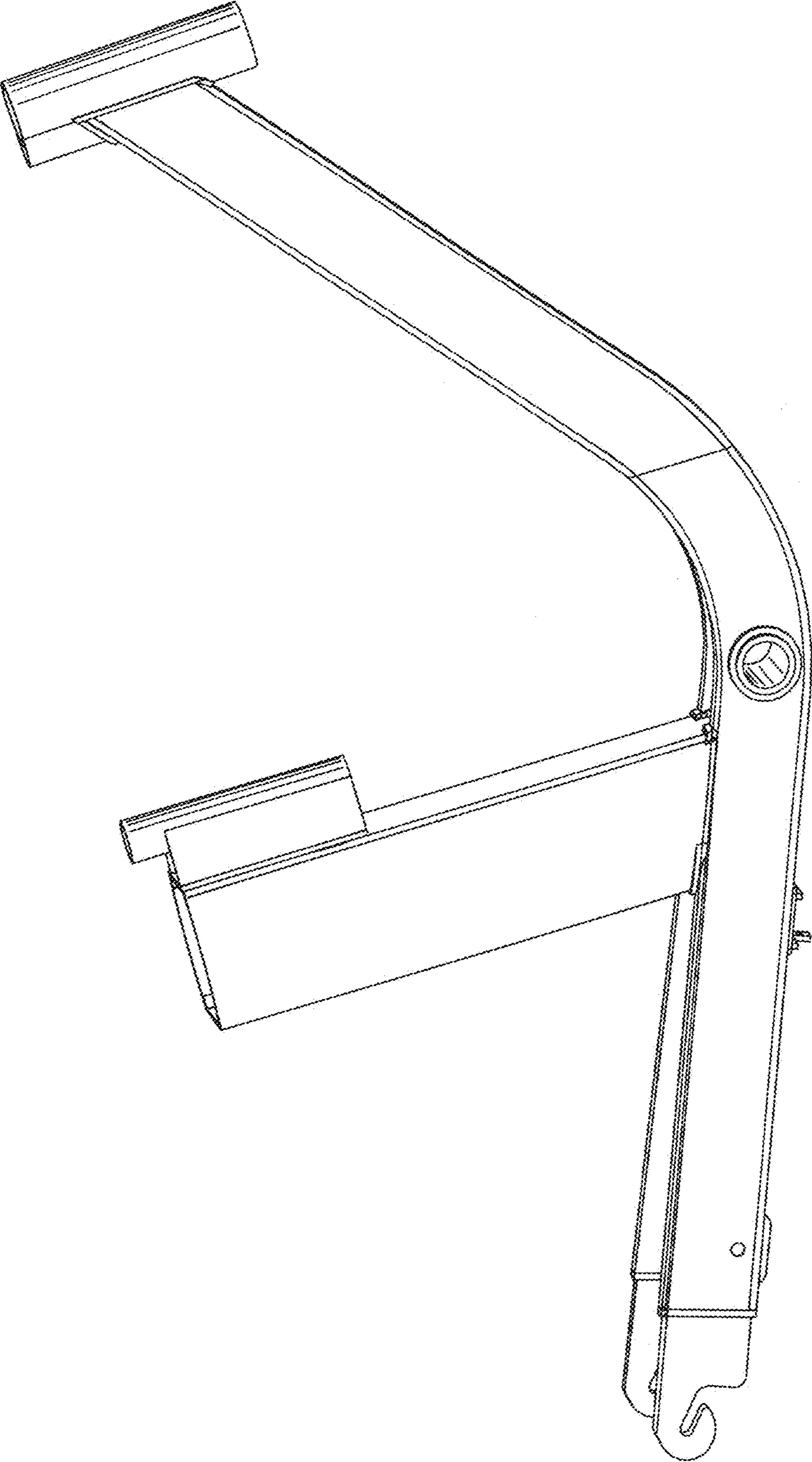

FIG. 8

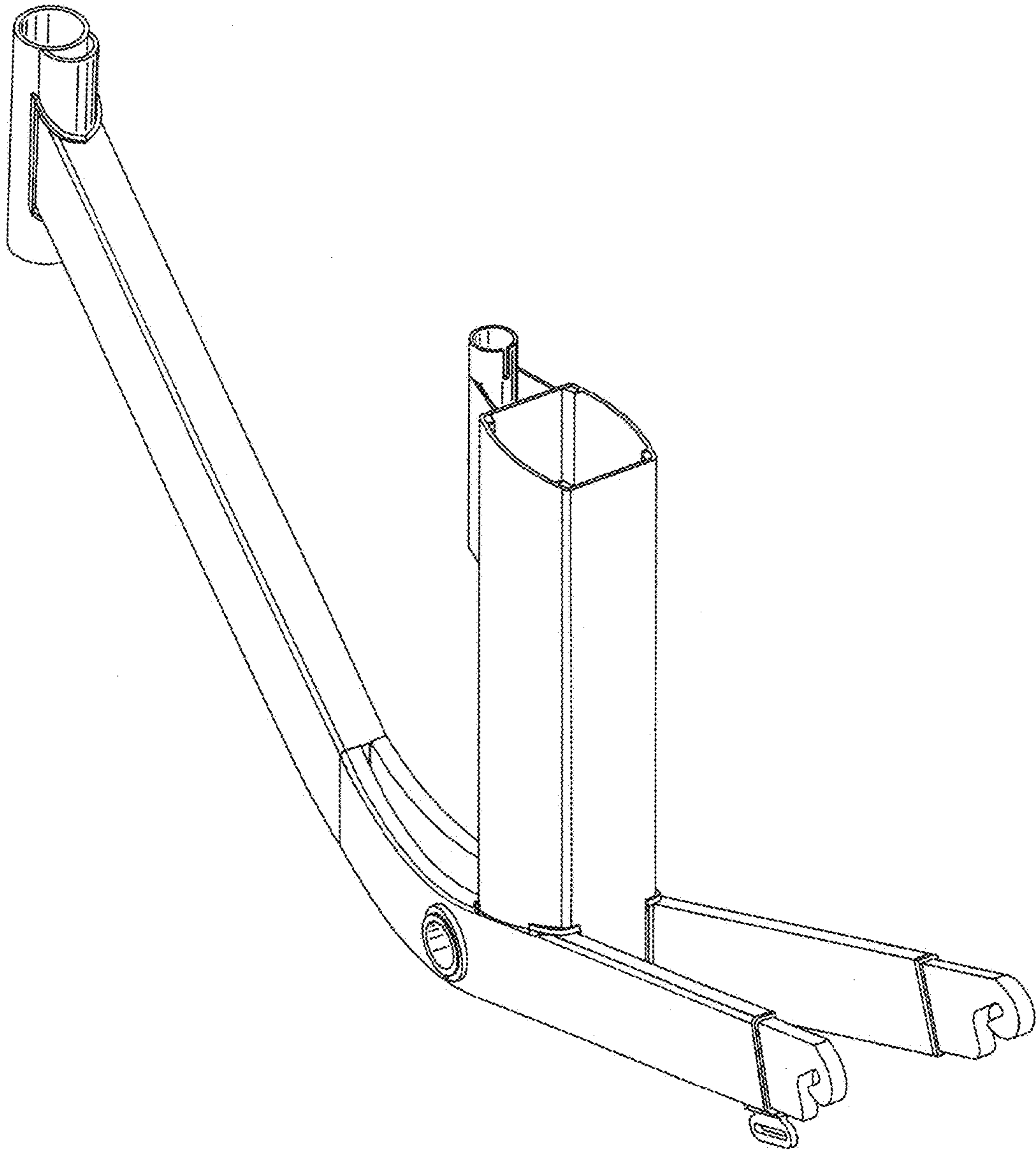

FIG. 9

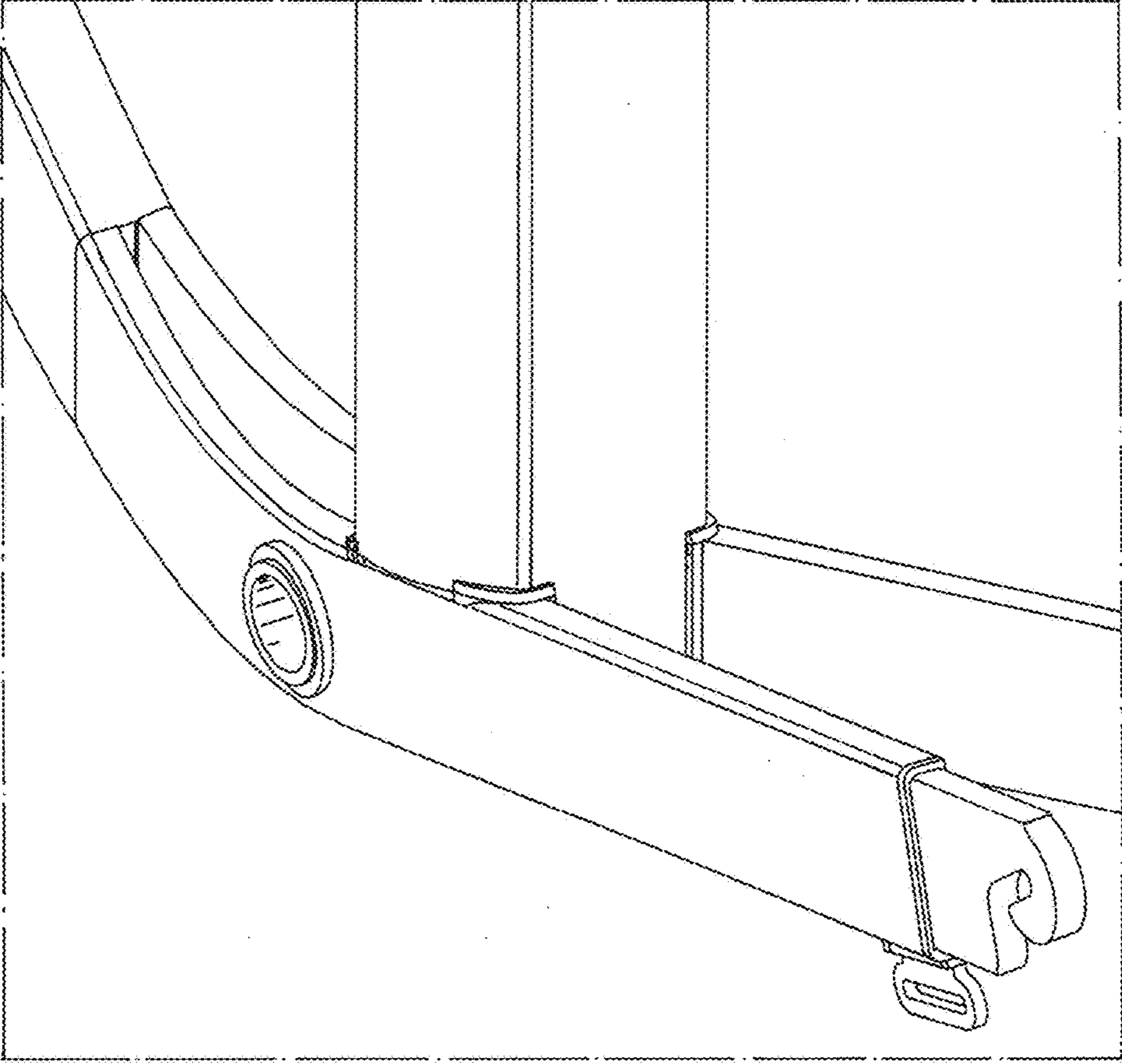

FIG. 10

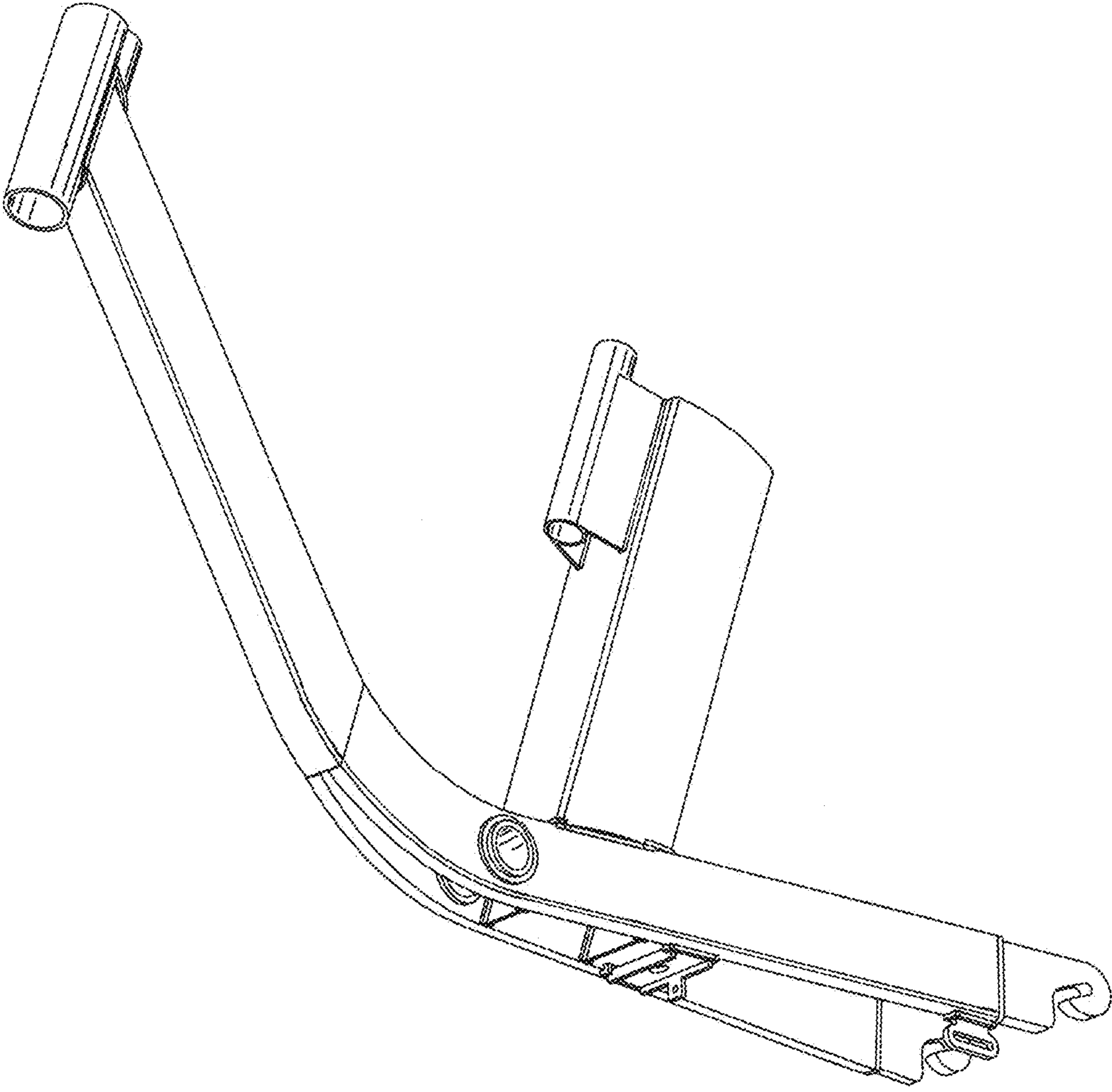

FIG. 11

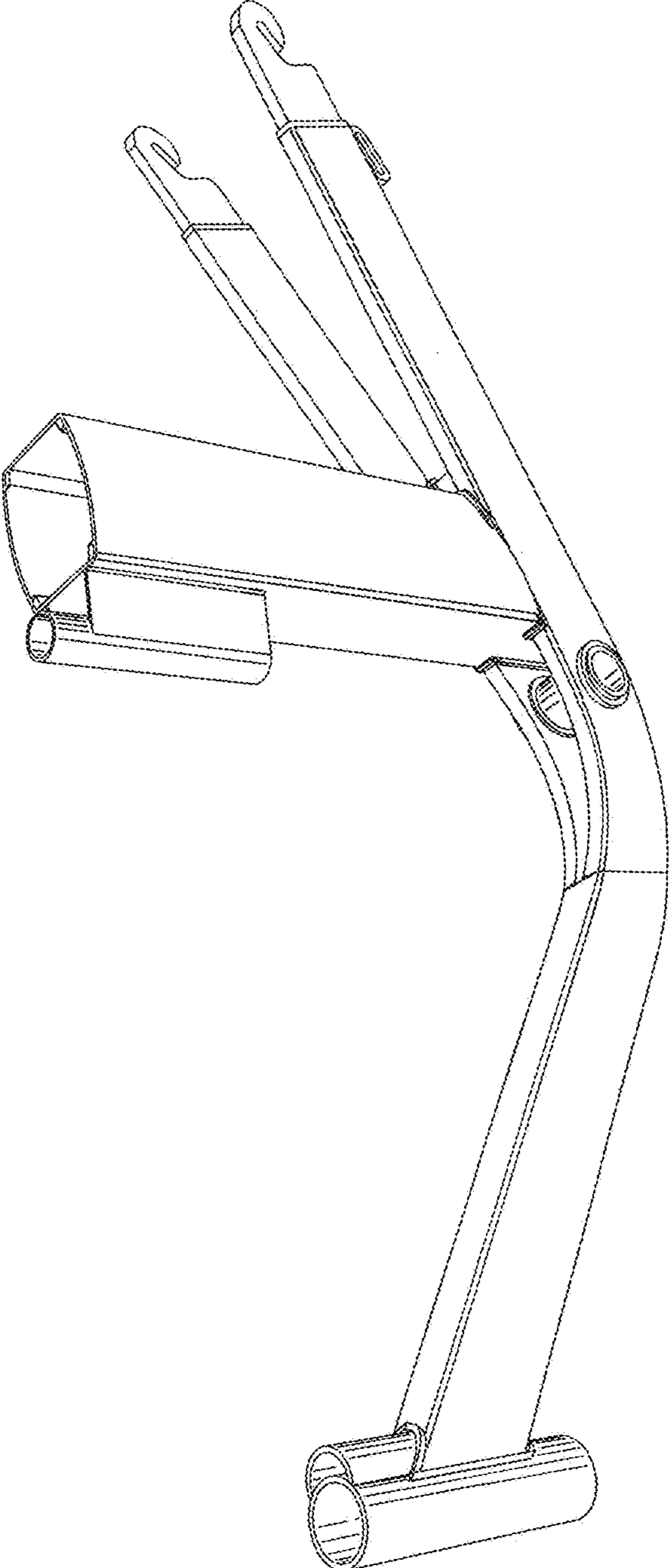

FIG. 12