



US00D799226S

(12) **United States Design Patent**
Grader et al.

(10) **Patent No.:** **US D799,226 S**

(45) **Date of Patent:** **** Oct. 10, 2017**

(54) **SEATING UNIT**

(71) Applicant: **British Airways Plc**, Harmondsworth,
West Drayton (GB)

(72) Inventors: **Paul Grader**, London (GB); **Peter
Cooke**, Sussex (GB)

(73) Assignee: **British Airways Plc**, Harmondsworth
(GB)

(**) Term: **15 Years**

(21) Appl. No.: **29/544,734**

(22) Filed: **Nov. 5, 2015**

Related U.S. Application Data

(62) Division of application No. 29/499,189, filed on Aug.
12, 2014, now Pat. No. Des. 765,999.

(30) **Foreign Application Priority Data**

Feb. 12, 2014 (GB) 4034250

(51) **LOC (10) Cl.** **06-01**

(52) **U.S. Cl.**
USPC **D6/356; D6/336**

(58) **Field of Classification Search**
USPC D6/33-338, 640, 643, 643.1, 644, 356
CPC A47C 17/00; A47C 17/02; A47C 17/12;
A47C 17/18; A47C 7/021; A47C 31/00;
A47C 3/16
See application file for complete search history.

(56) **References Cited**

U.S. PATENT DOCUMENTS

D66,116 S 12/1924 Farum
D314,869 S 2/1991 Entratter
5,024,398 A * 6/1991 Riedinger B64D 11/0015
244/118.5
D329,150 S 9/1992 Ball

D368,180 S 3/1996 Ball
D421,948 S * 3/2000 Dryburgh D12/195
6,059,364 A * 5/2000 Dryburgh A47C 1/0352
105/322
D439,063 S 3/2001 Round et al.
D439,425 S 3/2001 Park et al.
D443,990 S 6/2001 Beroth
D557,948 S 12/2007 Ng
D558,993 S 1/2008 Saint-Jalmes et al.
7,419,214 B2 9/2008 Plant
D591,520 S 5/2009 Orson et al.
D598,665 S 8/2009 Cloet et al.
D598,666 S 8/2009 Cloet et al.
7,607,612 B2 10/2009 Baatz et al.
D611,400 S 3/2010 Suge et al.
D612,312 S 3/2010 Davidson
D615,476 S 5/2010 Bock
D623,578 S 9/2010 Orson et al.
D653,883 S 2/2012 Ferry et al.
D661,116 S * 6/2012 Darbyshire D6/356

(Continued)

Primary Examiner — Deanna L Pratt

(74) *Attorney, Agent, or Firm* — Sterne, Kessler,
Goldstein & Fox P.L.L.C.

(57) **CLAIM**

The ornamental design for a seating unit, as shown and
described.

DESCRIPTION

FIG. 1 is a top view of a seating unit showing our new
design;
FIG. 2 is a top front perspective view thereof;
FIG. 3 is a side view thereof; and,
FIG. 4 is a front view thereof.
The shade lines in the figures show contour and not surface
ornamentation.
The dashed broken lines in the figures show portions of the
seating unit that form no part of the claimed design.

1 Claim, 4 Drawing Sheets

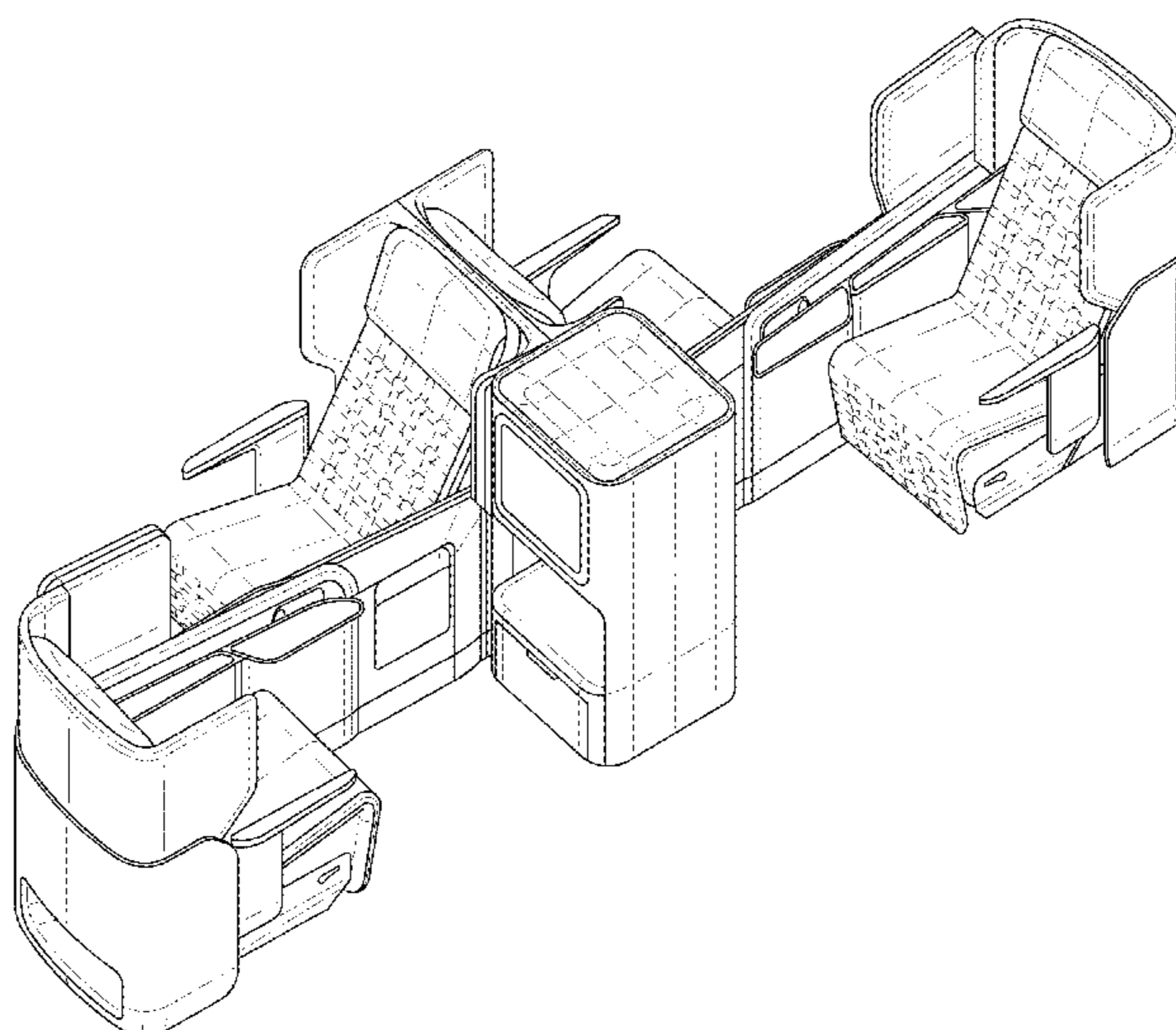

(56)

References Cited

U.S. PATENT DOCUMENTS

D695,033	S	12/2013	Salzberger et al.	
8,616,643	B2 *	12/2013	Darbyshire	B64D 11/06 297/340
D702,623	S	4/2014	Salzberger et al.	
D713,160	S *	9/2014	Roberts	D6/356
8,882,036	B2 *	11/2014	Henshaw	B64D 11/06 244/118.6
D718,945	S *	12/2014	Nicholas	D6/356
8,998,139	B2 *	4/2015	Dryburgh	B64D 11/06 244/118.6
D733,442	S *	7/2015	Dryburgh	D6/356
D741,075	S *	10/2015	Lawson	D6/338
D741,609	S *	10/2015	Williams	D6/338
9,302,774	B2 *	4/2016	Henshaw	B64D 11/06
2004/0232283	A1	11/2004	Ferry et al.	
2009/0050740	A1 *	2/2009	Saint-Jalmes	B60N 2/0232 244/118.6
2009/0146005	A1	6/2009	Bettell	
2010/0065683	A1	3/2010	Darbyshire	
2016/0122022	A1 *	5/2016	Cooke	B64C 1/18 244/118.6

* cited by examiner

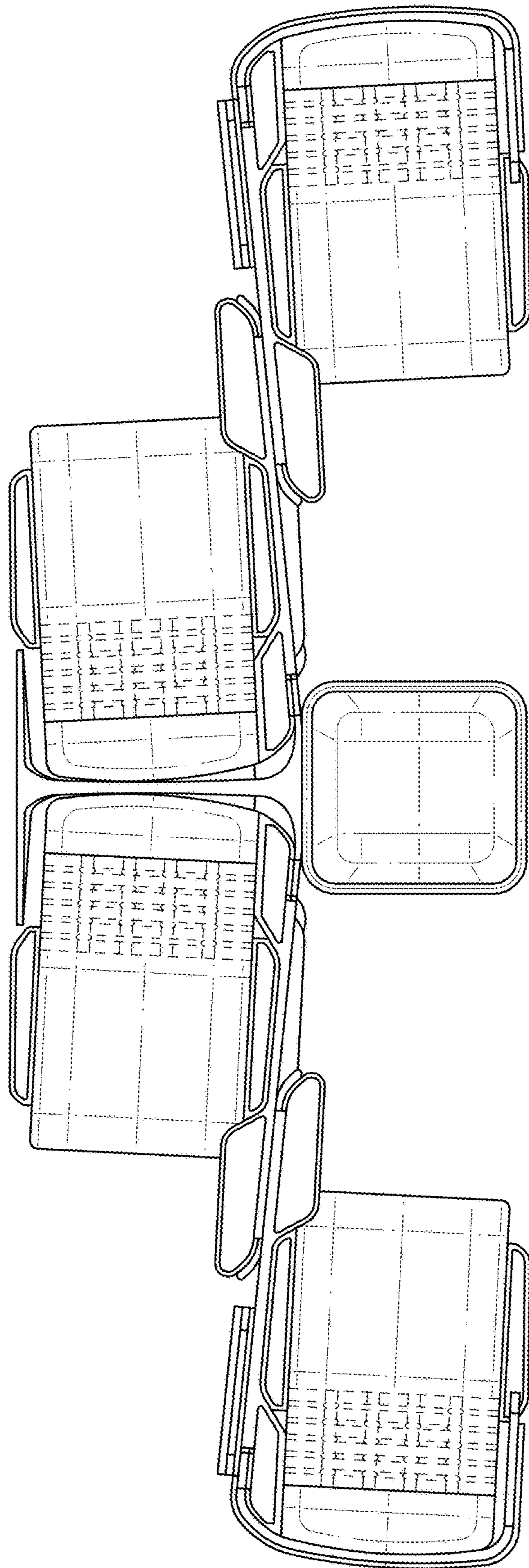

FIG. 1

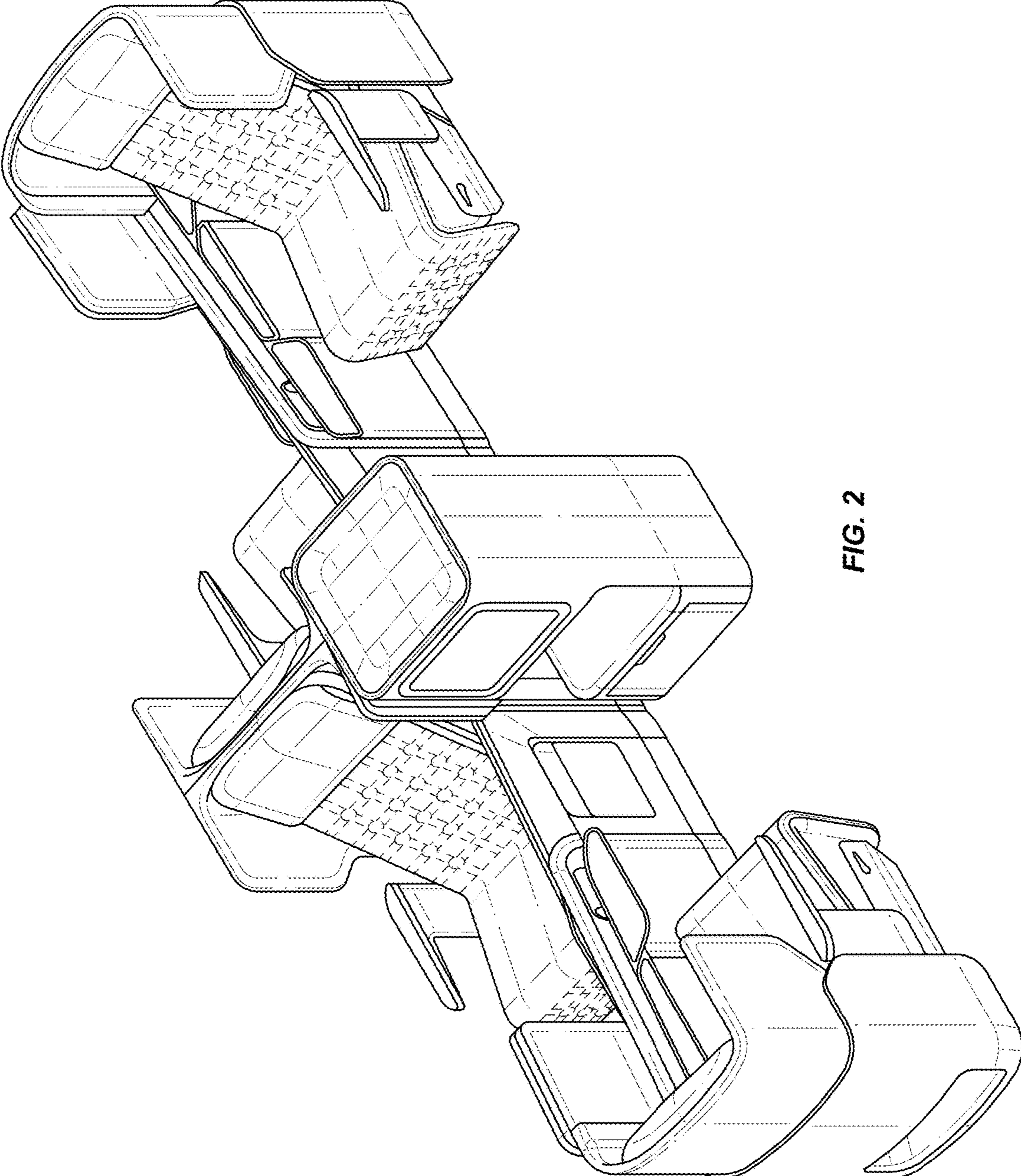

FIG. 2

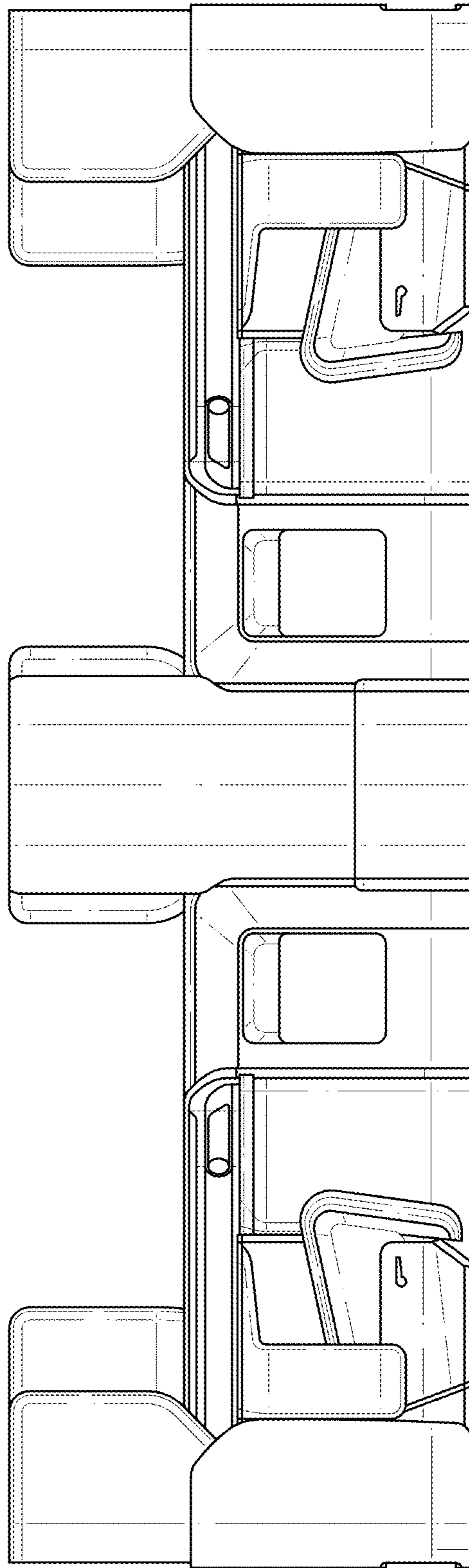

FIG. 3

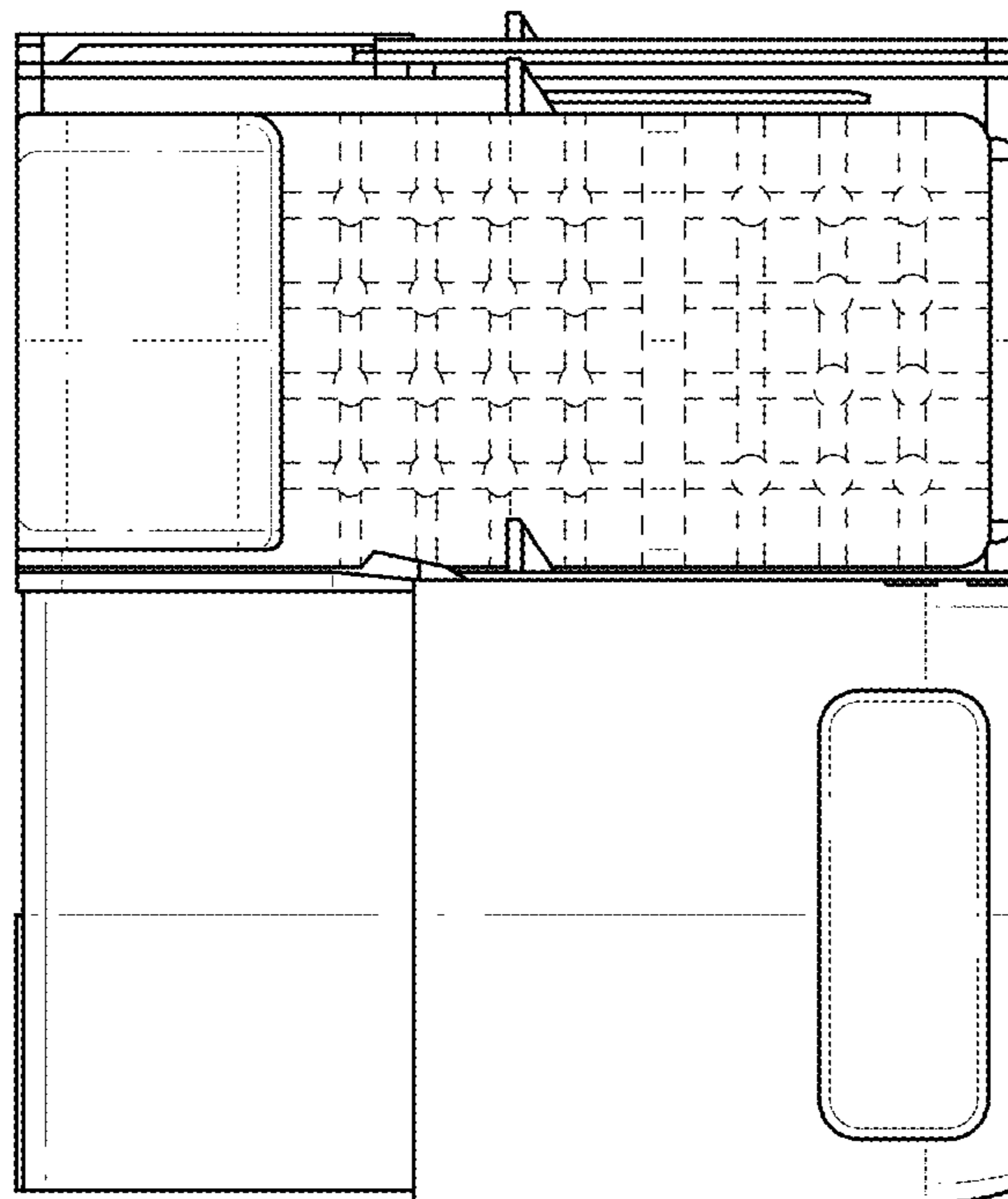

FIG. 4