



US00D799143S

(12) **United States Design Patent**
Cui

(10) **Patent No.:** **US D799,143 S**

(45) **Date of Patent:** **** Oct. 3, 2017**

(54) **ELECTRIC WINCH**

(71) Applicant: **NINGBO LIANDA WINCH CO. LTD.**, Ningbo, Zhejiang Province (CN)

(72) Inventor: **Xiaojun Cui**, Ningbo (JP)

(73) Assignee: **NINGBO LIANDA WINCH CO. LTD.**, Ningbo (CN)

(**) Term: **15 Years**

(21) Appl. No.: **29/564,011**

(22) Filed: **May 10, 2016**

(30) **Foreign Application Priority Data**

Jan. 22, 2016 (CN) 2016 3 023696

(51) **LOC (10) Cl.** **12-05**

(52) **U.S. Cl.**
USPC **D34/33**

(58) **Field of Classification Search**
USPC D34/33; 254/362, 356, 372, 380, 901,
254/382, 374, 316
CPC ... B66D 1/14; B66D 1/38; B66D 1/28; B66D
1/04; B66D 1/22; B66D 1/39; B66D
1/7405; B66D 1/00; B66D 1/08; B66D
1/26; B66D 1/36; B66D 1/505; B66D
1/7484; B66D 1/02

See application file for complete search history.

(56) **References Cited**

U.S. PATENT DOCUMENTS

6,604,731 B2 * 8/2003 Hodge B66D 1/22
254/344
6,864,650 B2 * 3/2005 Heravi B60P 3/12
318/266

D532,577 S * 11/2006 Elliott D34/33
D550,924 S * 9/2007 Huang D34/33
D599,524 S * 9/2009 Averill D34/33
D703,414 S * 4/2014 Fretz D34/33
D740,513 S * 10/2015 Fretz D34/33
D741,038 S * 10/2015 Huang D34/33
D742,614 S * 11/2015 Aho D34/33
D744,189 S * 11/2015 Fretz D34/33
D771,897 S * 11/2016 Aho D34/33
D776,395 S * 1/2017 Fretz D34/33
D779,768 S * 2/2017 Fretz D34/33

* cited by examiner

Primary Examiner — Cynthia Ramirez

(74) *Attorney, Agent, or Firm* — Oliff PLC

(57) **CLAIM**

The ornamental design for an electric winch, as shown and described.

DESCRIPTION

FIG. 1 is a first perspective view of an electric winch showing my new design;
FIG. 2 is a front view thereof;
FIG. 3 is a rear view thereof;
FIG. 4 is a left side view thereof;
FIG. 5 is a right side view thereof;
FIG. 6 is a bottom view thereof;
FIG. 7 is a top view thereof; and,
FIG. 8 is a second perspective view of the electric winch.

1 Claim, 7 Drawing Sheets

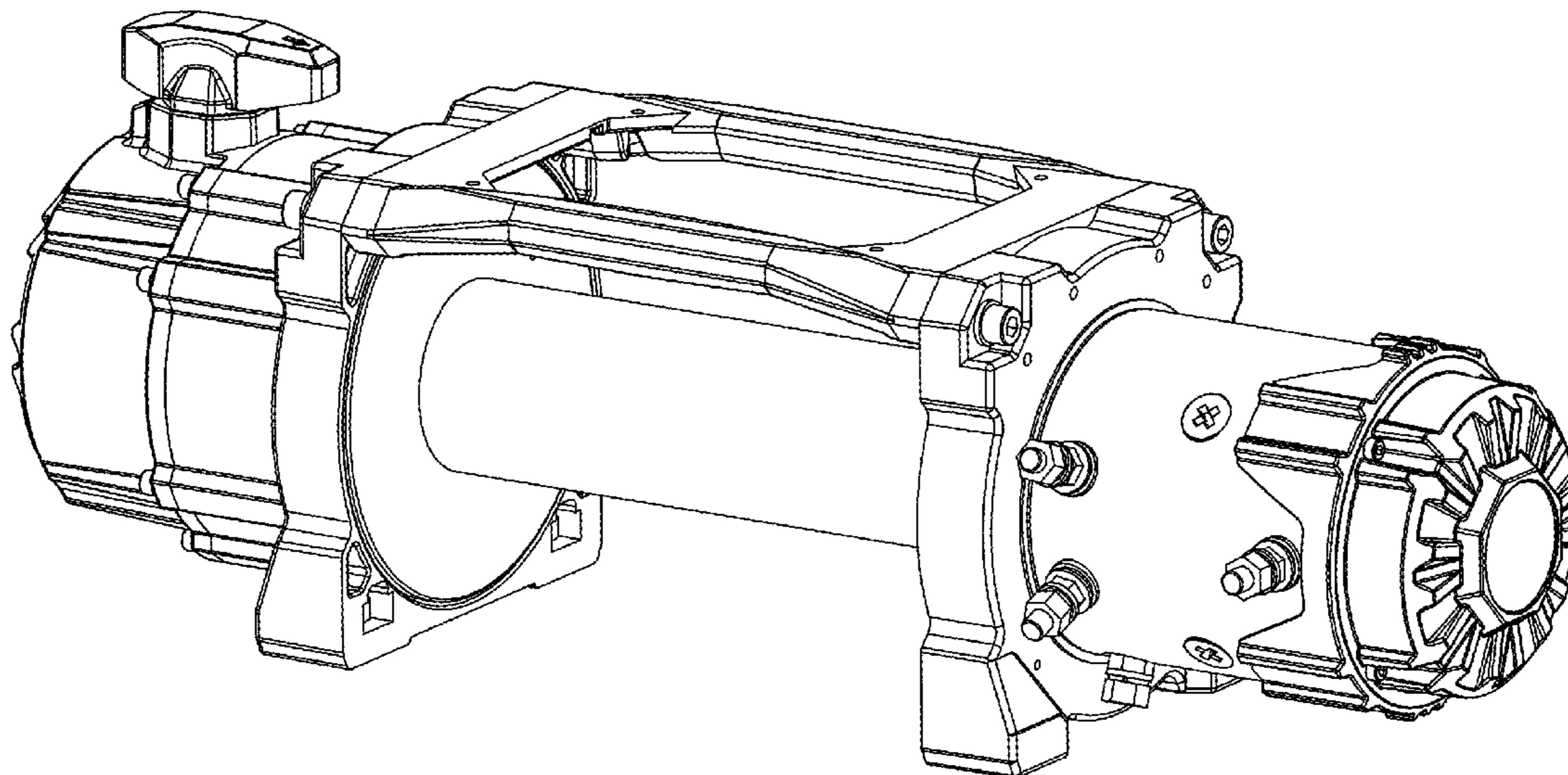

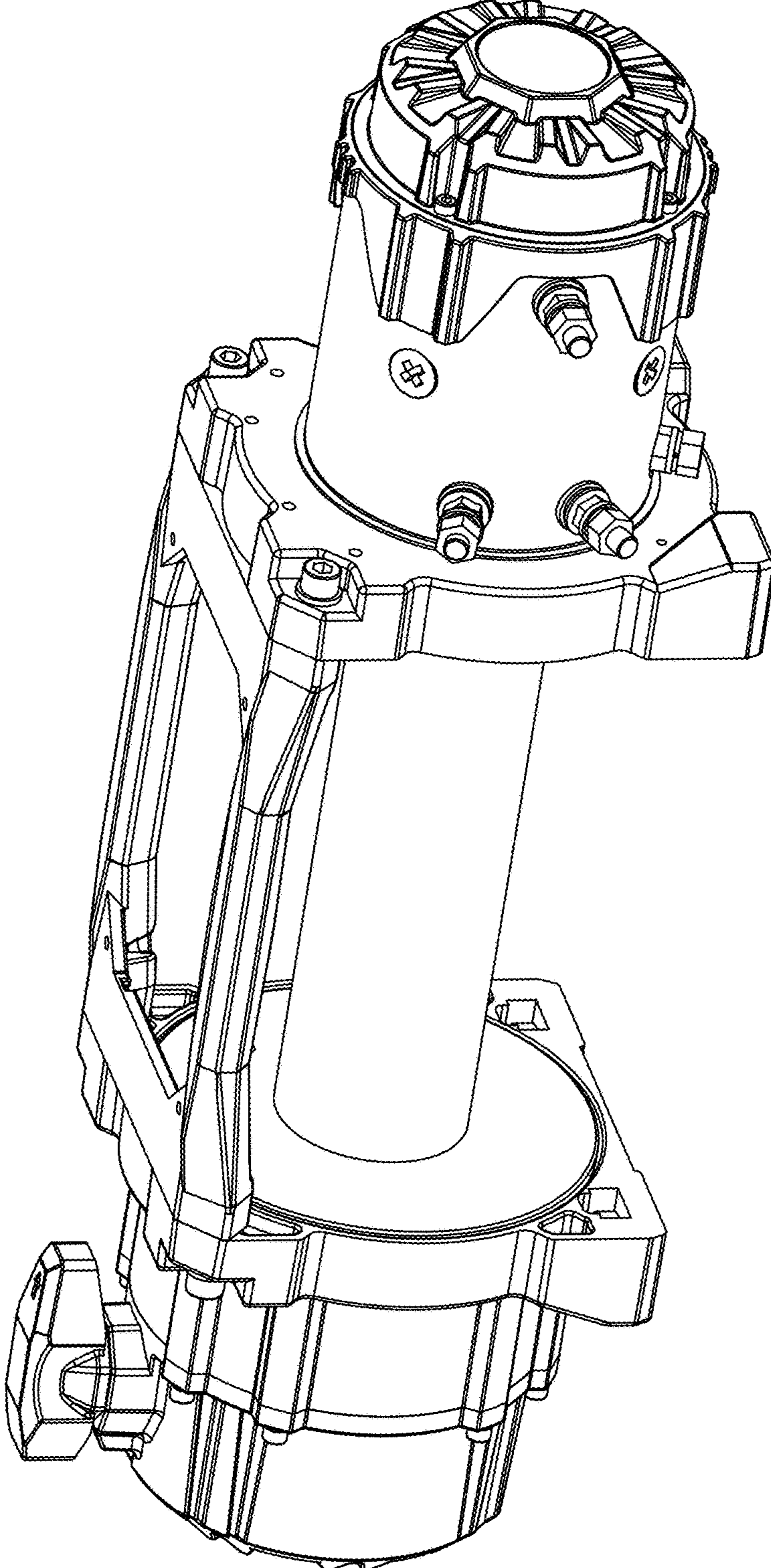

FIG. 1

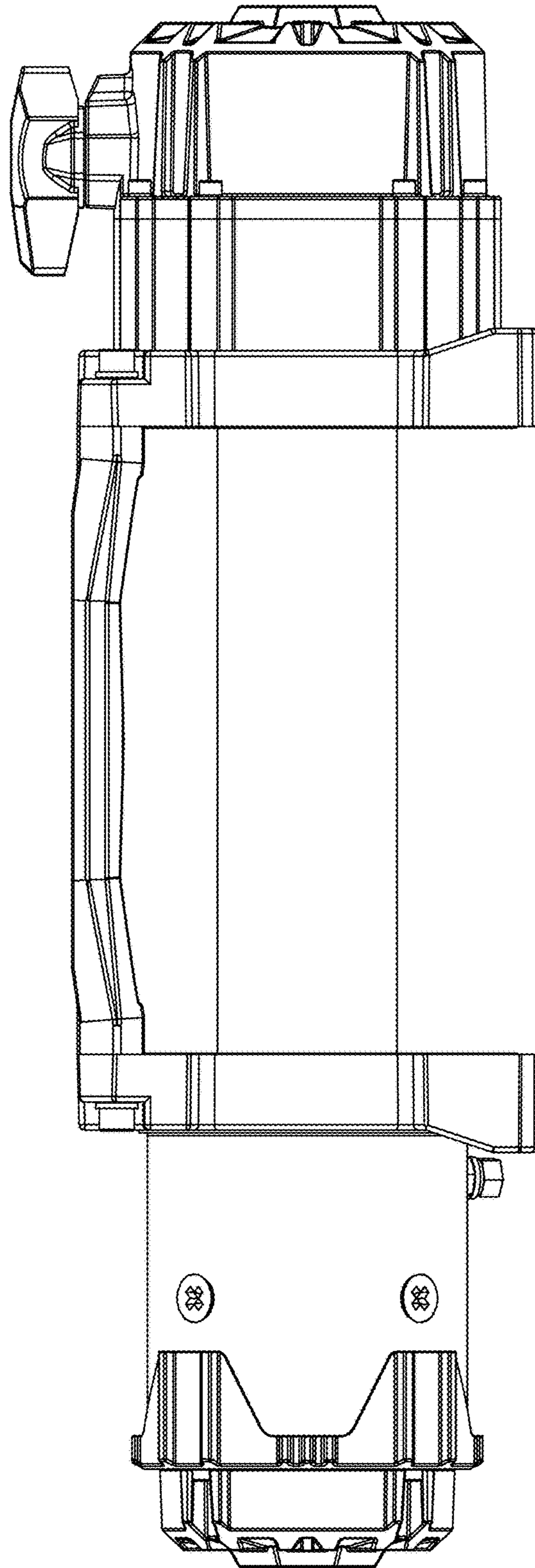

FIG. 2

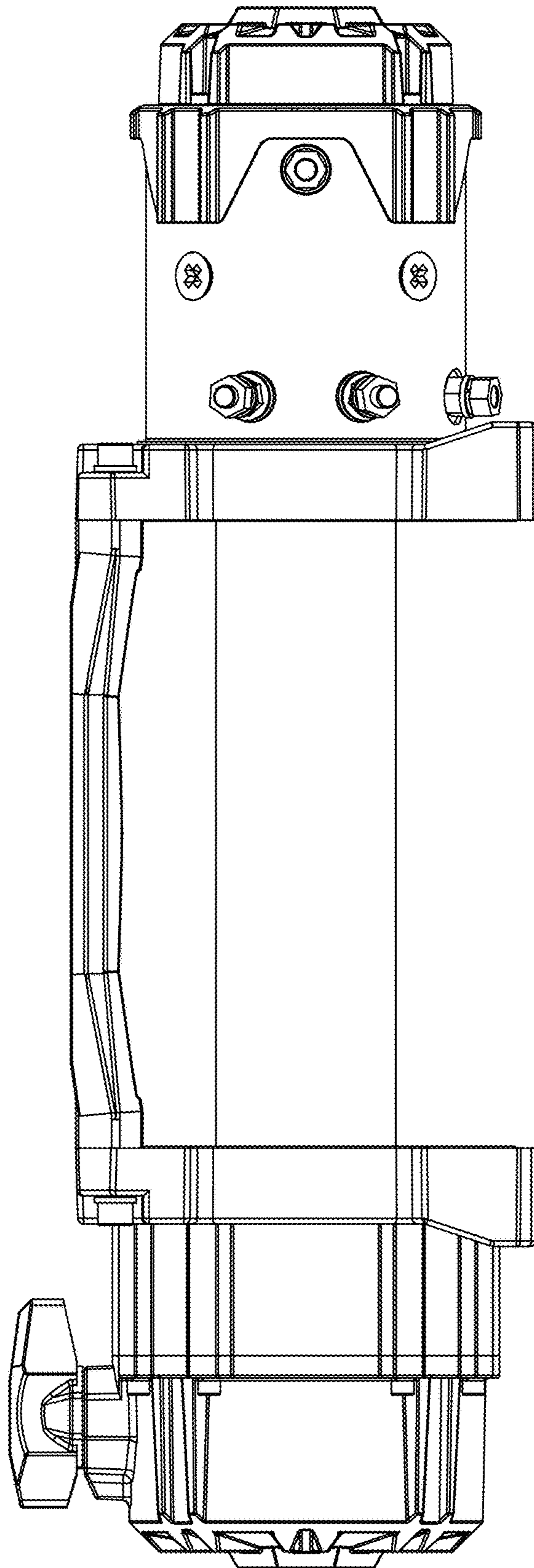

FIG. 3

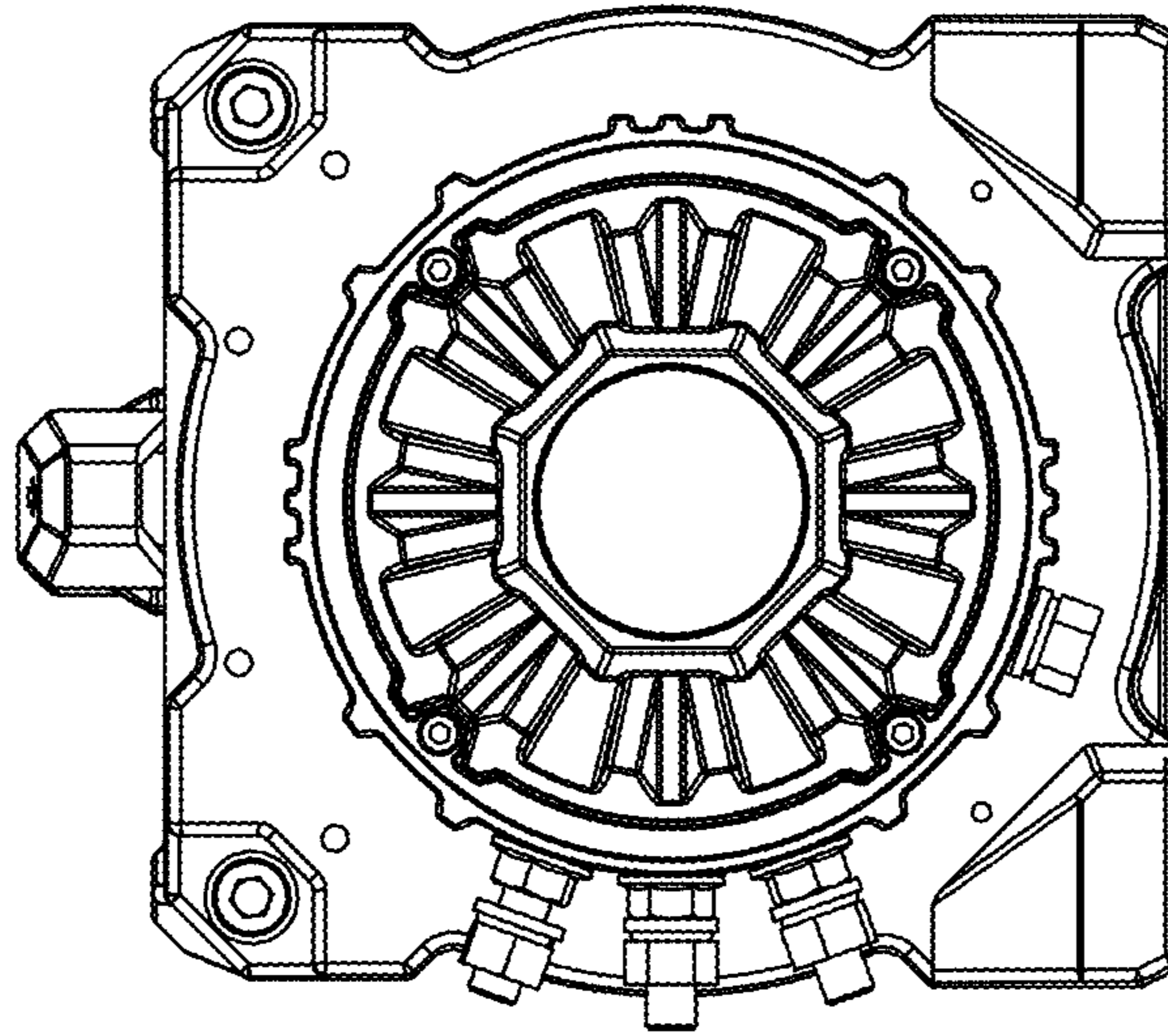

FIG. 4

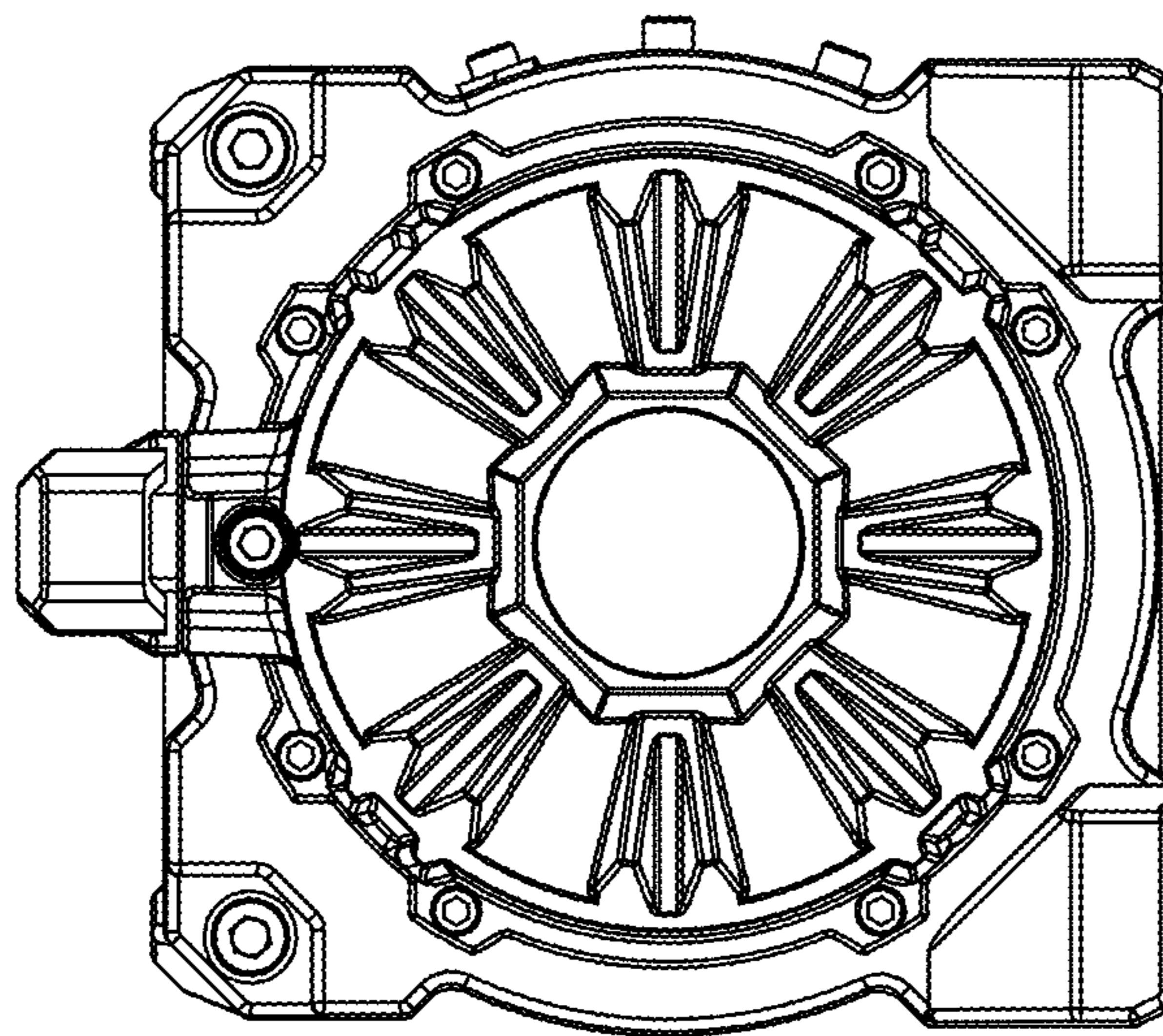

FIG. 5

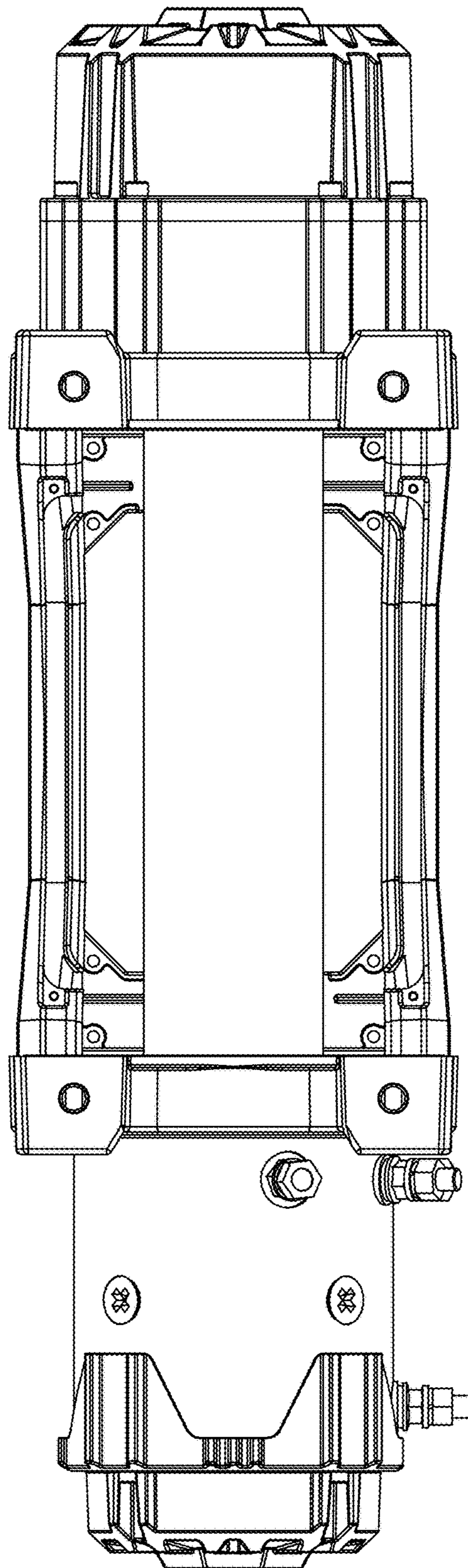

FIG. 6

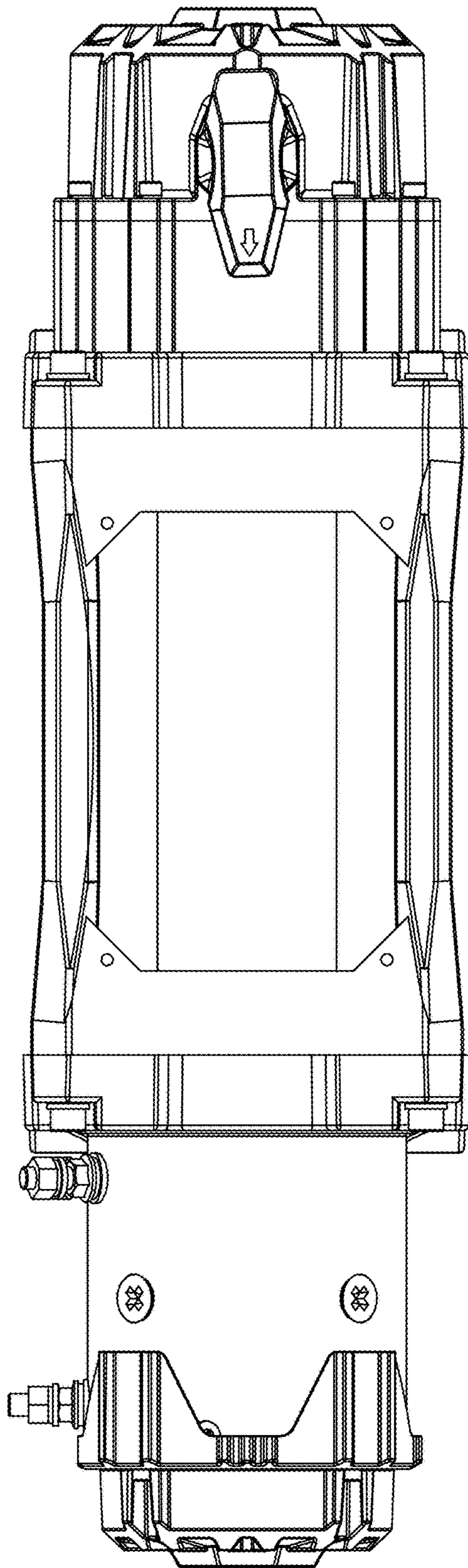

FIG. 7

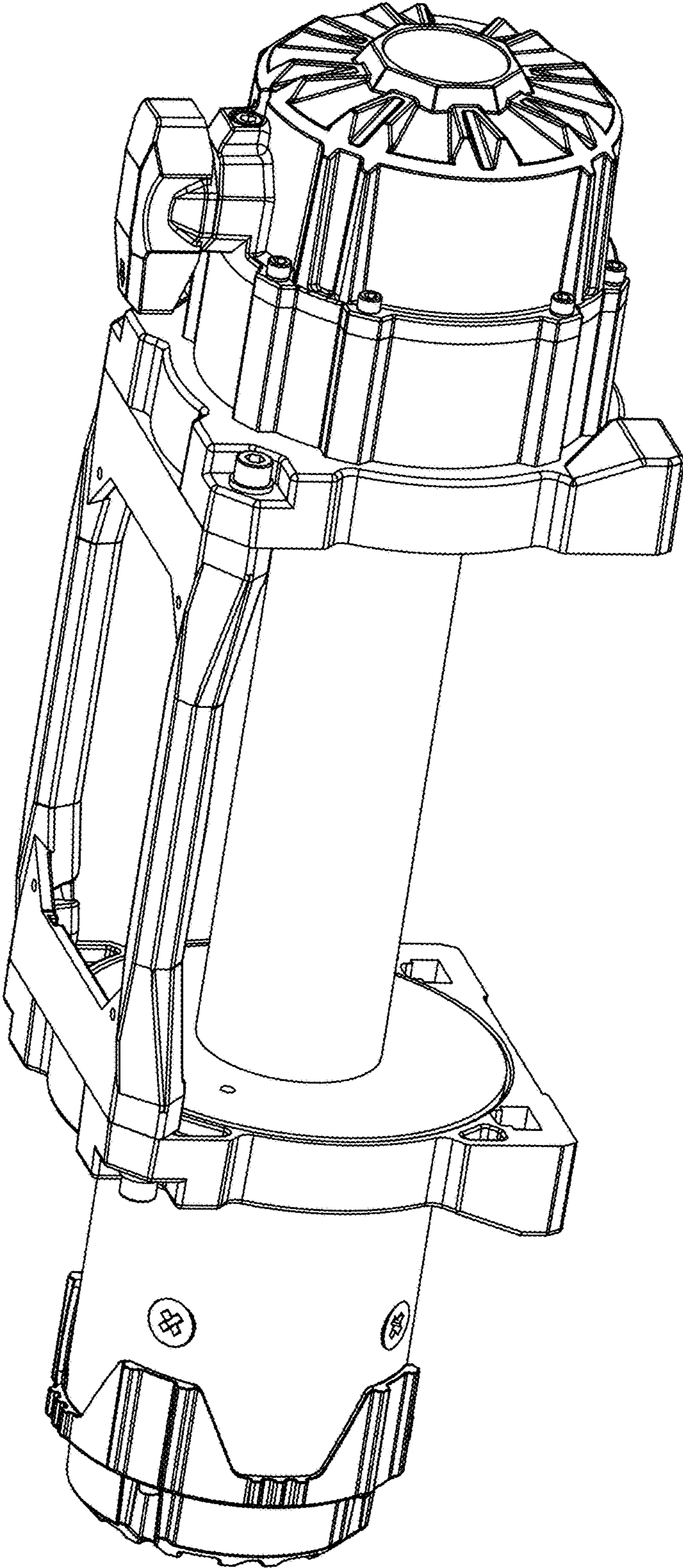

FIG. 8