



US00D798805S

(12) **United States Design Patent** (10) **Patent No.:** **US D798,805 S**  
**Schultz et al.** (45) **Date of Patent:** **\*\* Oct. 3, 2017**

(54) **TIRE SIDEWALL**

(71) Applicant: **Bridgestone Americas Tire Operations, LLC**, Nashville, TN (US)

(72) Inventors: **David E. Schultz**, Stow, OH (US);  
**Kevin E. Scheifele**, Atwater, OH (US);  
**Keith A. Dumigan**, Akron, OH (US)

(73) Assignee: **Bridgestone Americas Tire Operations, LLC**, Nashville, TN (US)

(\*\*) Term: **15 Years**

(21) Appl. No.: **29/565,621**

(22) Filed: **May 23, 2016**

**Related U.S. Application Data**

(63) Continuation-in-part of application No. 29/509,662, filed on Nov. 20, 2014, now abandoned.

(51) **LOC (10) Cl.** ..... **12-15**

(52) **U.S. Cl.**  
USPC ..... **D12/605**

(58) **Field of Classification Search**  
USPC ..... D12/500-605, 900  
CPC ..... B60C 1/00; B60C 13/00; B60C 13/02  
See application file for complete search history.

(56) **References Cited**

**U.S. PATENT DOCUMENTS**

|             |         |                 |
|-------------|---------|-----------------|
| D379,168 S  | 5/1997  | Ratliff, Jr.    |
| D380,718 S  | 7/1997  | Ratliff, Jr.    |
| 5,645,661 A | 7/1997  | Clementz et al. |
| D385,834 S  | 11/1997 | Ratliff, Jr.    |
| 5,807,446 A | 9/1998  | Ratliff, Jr.    |
| D412,476 S  | 8/1999  | Clementz et al. |

(Continued)

*Primary Examiner* — Robert M Spear

*Assistant Examiner* — John Voytek

(74) *Attorney, Agent, or Firm* — Shaun J. Fox

(57) **CLAIM**

The ornamental design for a tire sidewall, as shown and described.

**DESCRIPTION**

FIG. 1 is a side elevational view of a first, second, third and fourth embodiment of our new tire sidewall design; FIG. 2 is a cross-sectional view along cross-section line A-A of FIG. 1 of a first embodiment of our new tire design; FIG. 3 is cross-sectional view along cross-section line A-A of FIG. 1 a second embodiment of our new tire design; FIG. 4 is cross-sectional view along cross-section line A-A of FIG. 1 of a third embodiment of our new tire design; FIG. 5 is cross-sectional view along cross-section line A-A of FIG. 1 of a fourth embodiment of our new tire design; FIG. 6 is a side elevational view of a fifth, sixth, and seventh embodiment of our new tire sidewall design; FIG. 7 is a cross-sectional view along cross-section line B-B of FIG. 6 of a fifth embodiment of our new tire design; FIG. 8 is a cross-sectional view along cross-section line B-B of FIG. 6 of a sixth embodiment of our new tire design; and, FIG. 9 is a side elevational view of a seventh embodiment of our new tire sidewall design.

For clarity, variations in the linear surface shading represent elements of the design having a contrasting appearance due to the differences in surface treatment or depth as shown. The broken lines defining the tire tread, inner bead, inner bead, and portions of the tire sidewall represent unclaimed environmental subject matter; the broken lines immediately adjacent the solid line showing of the tire sidewall represent the boundaries of the claimed design but form no part thereof.

**1 Claim, 9 Drawing Sheets**

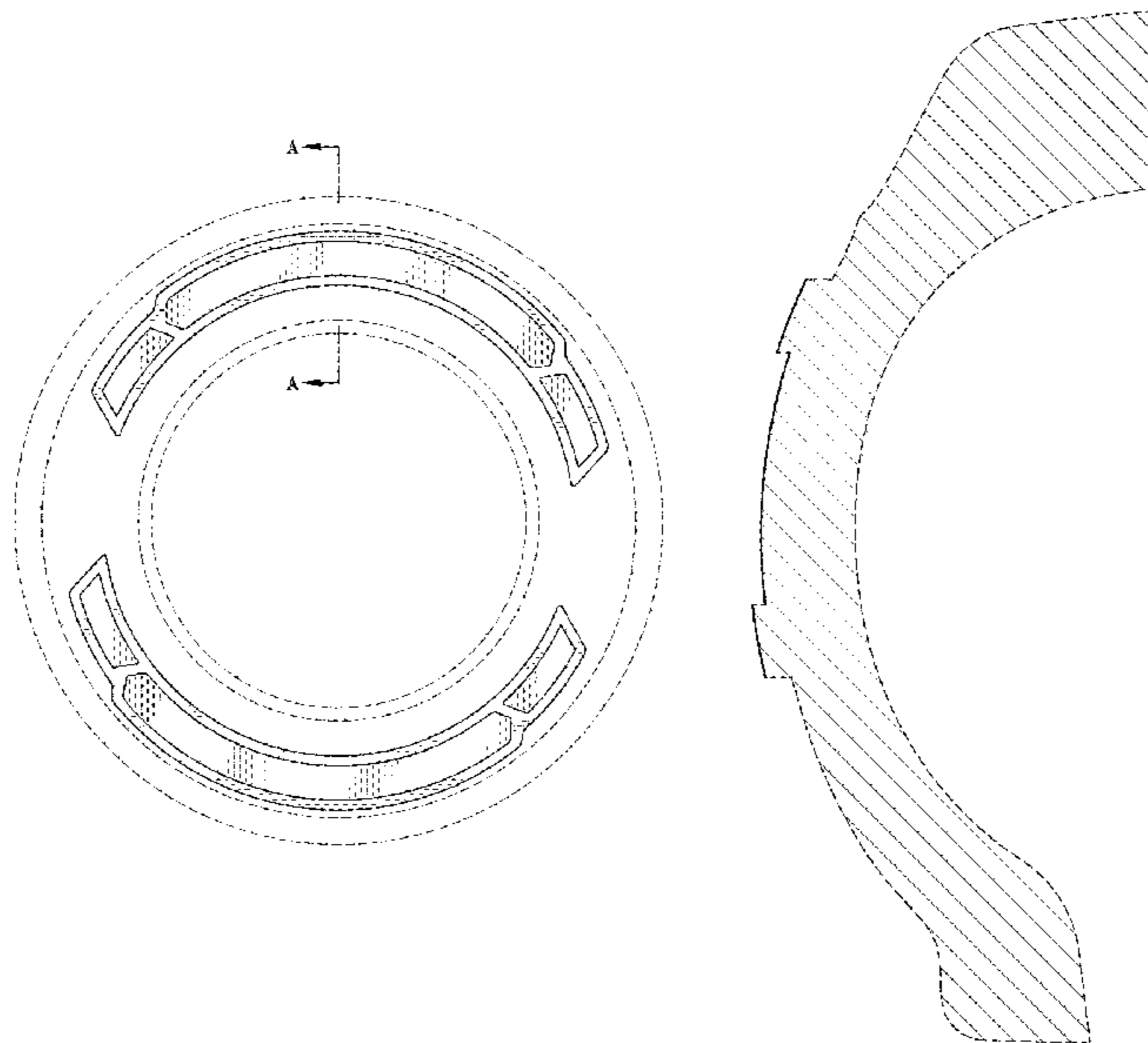

(56)

References Cited

U.S. PATENT DOCUMENTS

|            |         |                |                 |         |                  |         |
|------------|---------|----------------|-----------------|---------|------------------|---------|
| D492,648 S | 7/2004  | Maxwell et al. | D593,487 S      | 6/2009  | Takahashi        |         |
| D500,013 S | 12/2004 | Maxwell et al. | D593,939 S      | 6/2009  | Maxwell          |         |
| D503,146 S | 3/2005  | Maxwell et al. | D596,118 S      | 7/2009  | Frappart         |         |
| D506,435 S | 6/2005  | Maxwell et al. | D597,025 S      | 7/2009  | Fujita           |         |
| D517,003 S | 3/2006  | Shondel        | D597,480 S      | 8/2009  | Umstot et al.    |         |
| D540,250 S | 4/2007  | Shondel        | D598,843 S      | 8/2009  | Maxwell          |         |
| D540,740 S | 4/2007  | Maxwell et al. | D599,284 S      | 9/2009  | Misumi           |         |
| D541,210 S | 4/2007  | Maxwell et al. | D602,427 S      | 10/2009 | Takahashi        |         |
| D541,211 S | 4/2007  | Shondel et al. | D606,013 S      | 12/2009 | Reese et al.     |         |
| D542,219 S | 5/2007  | Shondel et al. | D606,488 S      | 12/2009 | Scheifele        |         |
| D542,220 S | 5/2007  | Shondel et al. | D606,933 S      | 12/2009 | Palma et al.     |         |
| D543,496 S | 5/2007  | Shondel et al. | D608,273 S      | 1/2010  | Scheifele et al. |         |
| D543,497 S | 5/2007  | Maxwell et al. | D608,275 S      | 1/2010  | Maxwell          |         |
| D543,932 S | 6/2007  | Shondel        | D610,978 S      | 3/2010  | Harvey et al.    |         |
| D543,933 S | 6/2007  | Shondel        | D610,980 S      | 3/2010  | Shondel          |         |
| D544,831 S | 6/2007  | Kikkawa et al. | D610,981 S      | 3/2010  | Shondel          |         |
| D547,261 S | 7/2007  | Shondel et al. | D614,123 S      | 4/2010  | Harvey           |         |
| D549,165 S | 8/2007  | Shondel et al. | D628,959 S      | 12/2010 | Harvey           |         |
| D549,168 S | 8/2007  | Shondel et al. | D629,745 S      | 12/2010 | Shondel          |         |
| D550,149 S | 9/2007  | Shondel        | D638,783 S      | 5/2011  | Endou et al.     |         |
| D550,150 S | 9/2007  | Shondel        | D638,784 S      | 5/2011  | Scheifele        |         |
| D550,151 S | 9/2007  | Maxwell        | D640,187 S      | 6/2011  | Fontaine et al.  |         |
| D552,535 S | 10/2007 | Smith          | 8,006,732 B2    | 8/2011  | Itoi             |         |
| D552,537 S | 10/2007 | Franks et al.  | D650,323 S      | 12/2011 | Morito et al.    |         |
| D553,076 S | 10/2007 | Miyasaka       | D656,089 S *    | 3/2012  | Miyazaki         | D12/605 |
| D557,202 S | 12/2007 | Shondel        | D656,090 S      | 3/2012  | Sato             |         |
| D558,138 S | 12/2007 | Shondel        | D662,871 S      | 7/2012  | Miyazaki         |         |
| D561,089 S | 2/2008  | Maxwell        | D662,877 S      | 7/2012  | Arrant et al.    |         |
| D563,310 S | 3/2008  | Shondel        | D666,143 S      | 8/2012  | Sato             |         |
| D567,169 S | 4/2008  | Maxwell et al. | 8,381,786 B2    | 2/2013  | Ebiko et al.     |         |
| D568,236 S | 5/2008  | Holden et al.  | D681,546 S      | 5/2013  | Sato             |         |
| D569,792 S | 5/2008  | Holden et al.  | D681,547 S      | 5/2013  | Sato             |         |
| D569,793 S | 5/2008  | Dixon          | D682,191 S      | 5/2013  | Ebiko et al.     |         |
| D571,287 S | 6/2008  | Dixon          | D683,303 S      | 5/2013  | Ebiko et al.     |         |
| D574,320 S | 8/2008  | Dixon          | D693,761 S      | 11/2013 | Nakamura         |         |
| D581,352 S | 11/2008 | Harvey         | D699,665 S      | 2/2014  | Maxwell et al.   |         |
| D581,353 S | 11/2008 | Harvey         | D701,826 S *    | 4/2014  | Morito           | D12/605 |
| D581,354 S | 11/2008 | Harvey         | D726,646 S *    | 4/2015  | Scheifele        | D12/605 |
| D583,313 S | 12/2008 | Harvey         | D749,499 S *    | 2/2016  | Iwabuchi         | D12/605 |
| D585,016 S | 1/2009  | Weimer et al.  | D750,555 S *    | 3/2016  | Iwabuchi         | D12/605 |
| D585,017 S | 1/2009  | Shondel        | D754,063 S *    | 4/2016  | Iwabuchi         | D12/605 |
| D585,018 S | 1/2009  | Shondel        | D754,595 S *    | 4/2016  | Tokizaki         | D12/605 |
| D588,529 S | 3/2009  | Reese et al.   | D769,182 S *    | 10/2016 | Iwabuchi         | D12/605 |
| D588,531 S | 3/2009  | Maxwell        | D769,807 S *    | 10/2016 | Ishikawa         | D12/605 |
|            |         |                | 2005/0224153 A1 | 10/2005 | Speyer et al.    |         |
|            |         |                | 2006/0266456 A1 | 11/2006 | Speyer et al.    |         |

\* cited by examiner

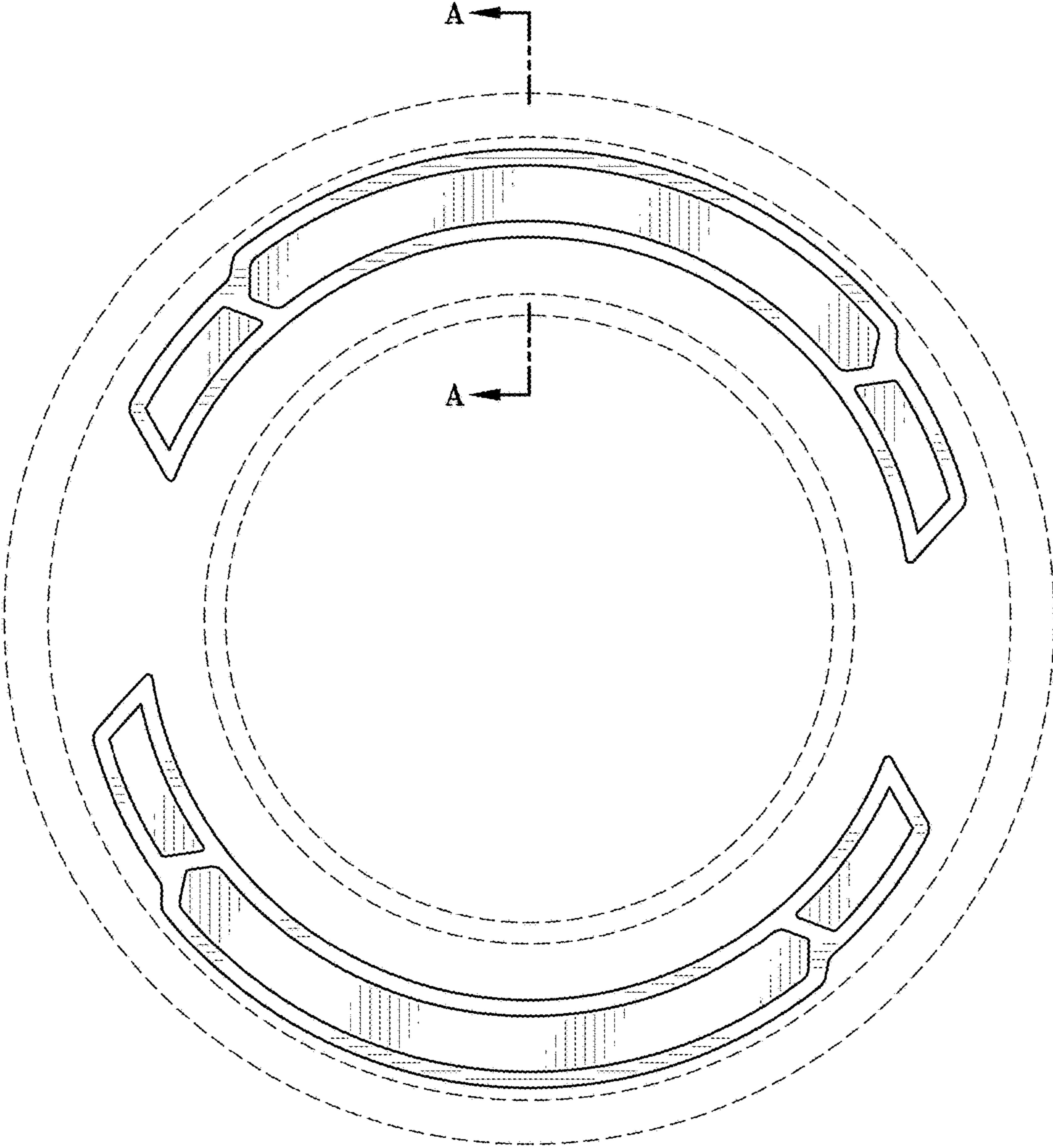

FIG. 1

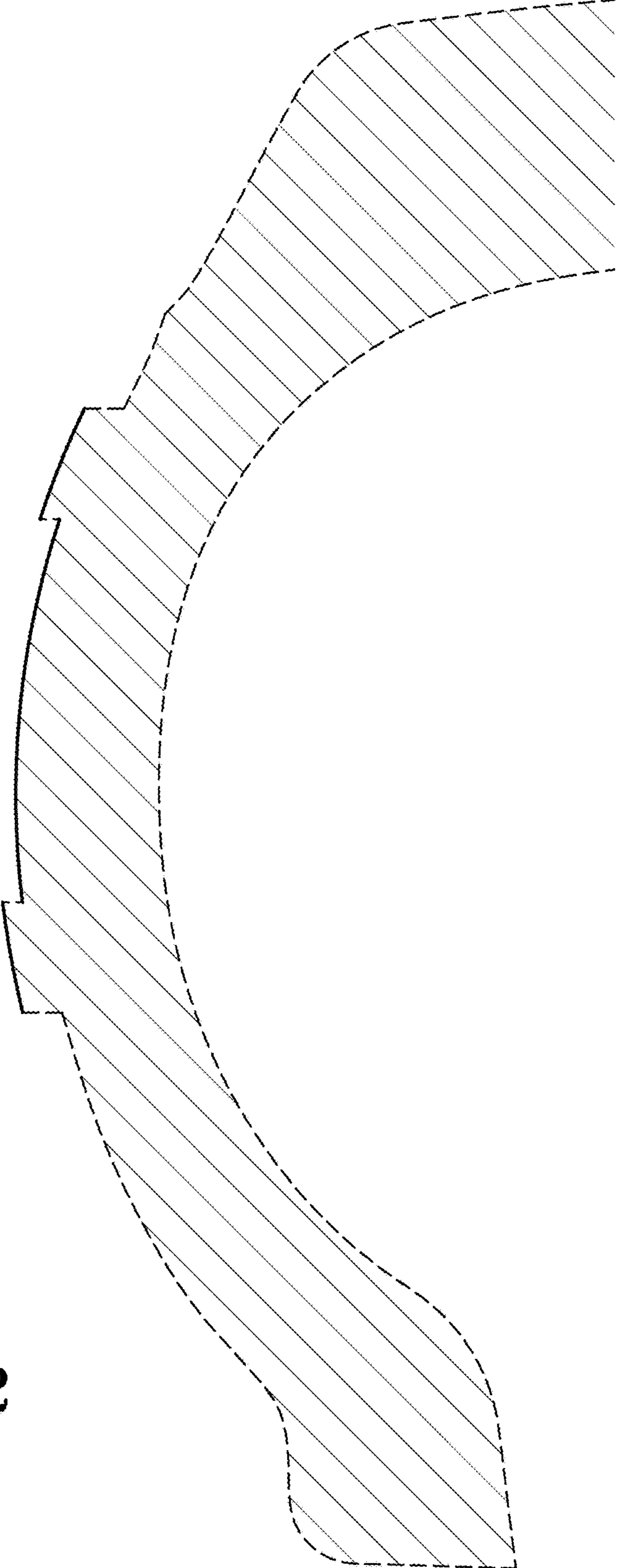

FIG.2

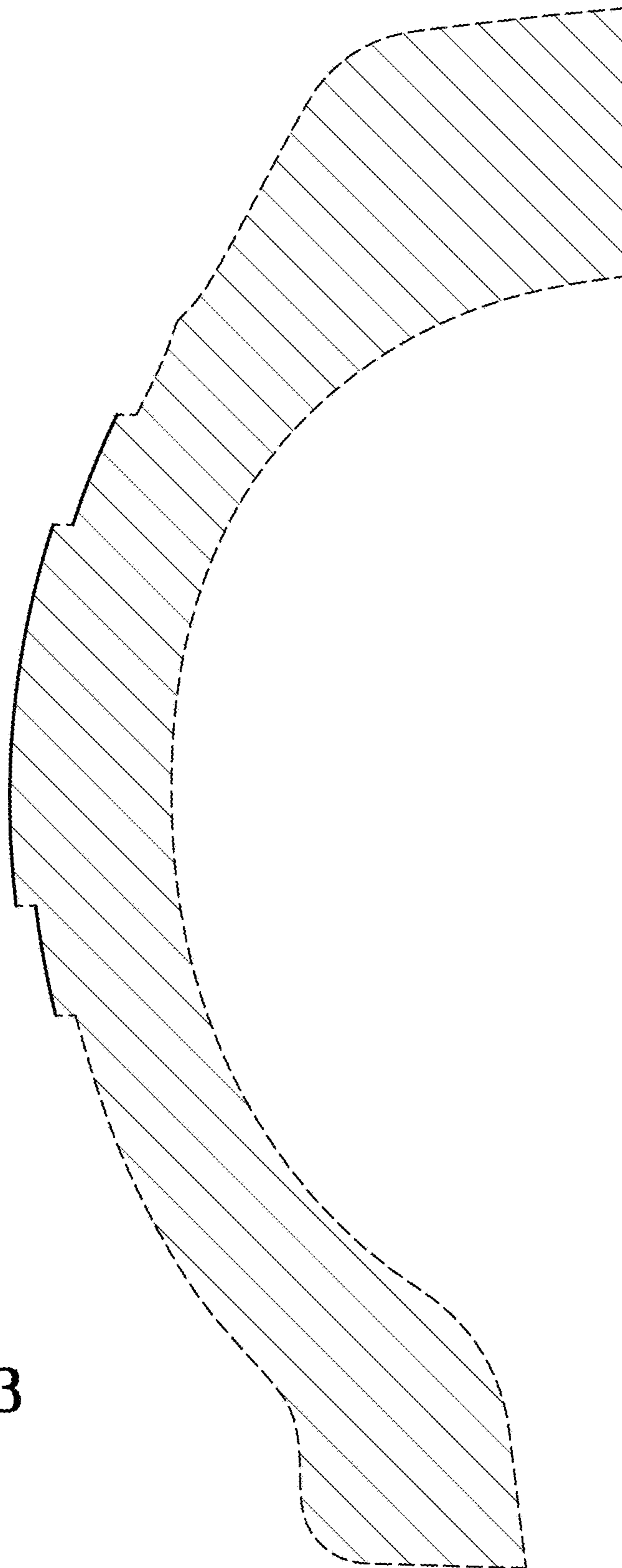

FIG. 3

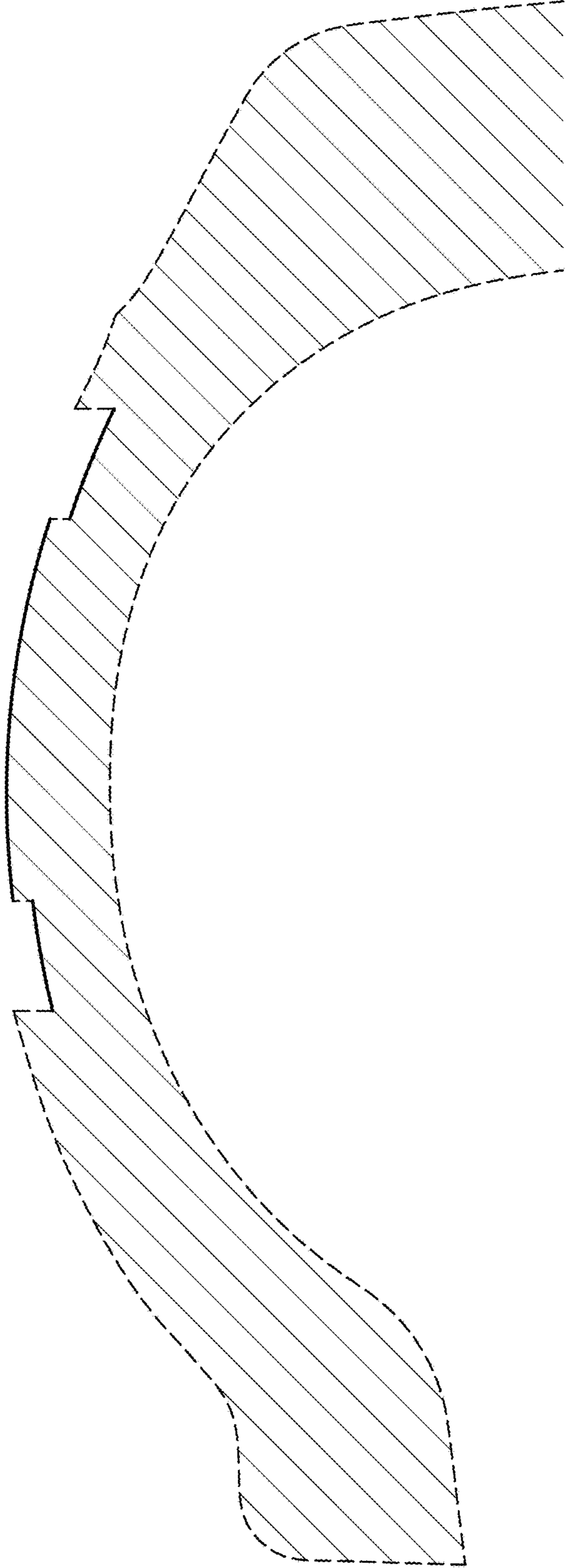

FIG. 4

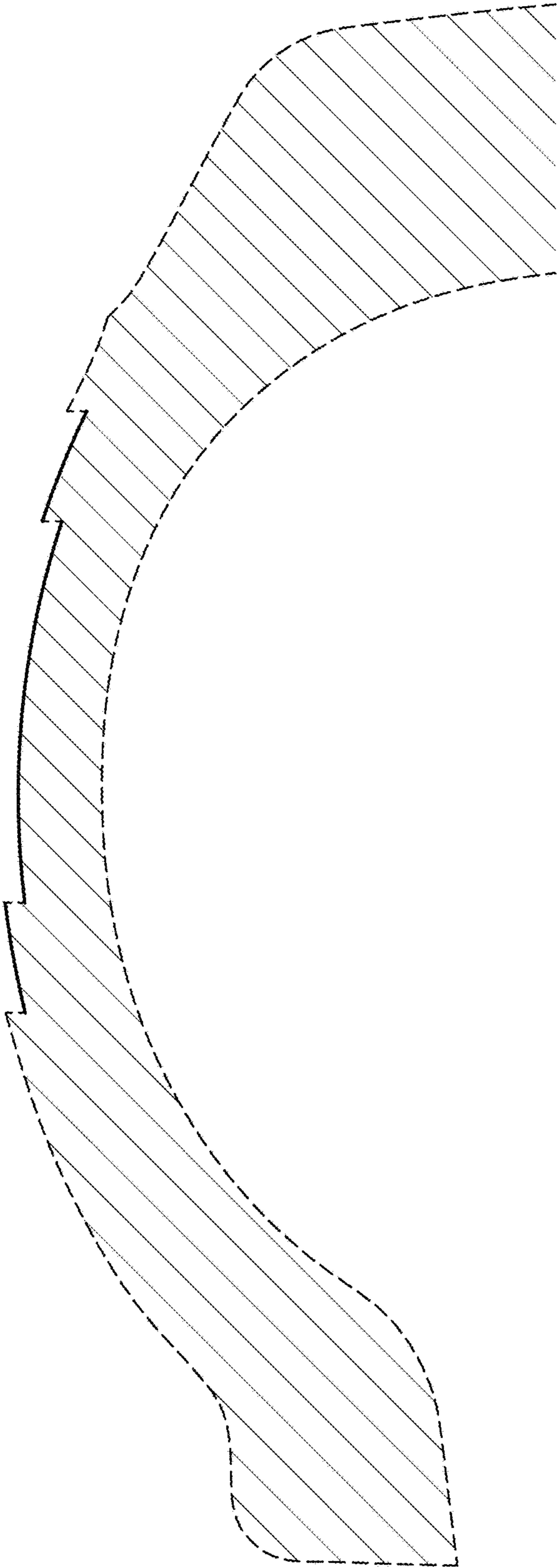

FIG.5

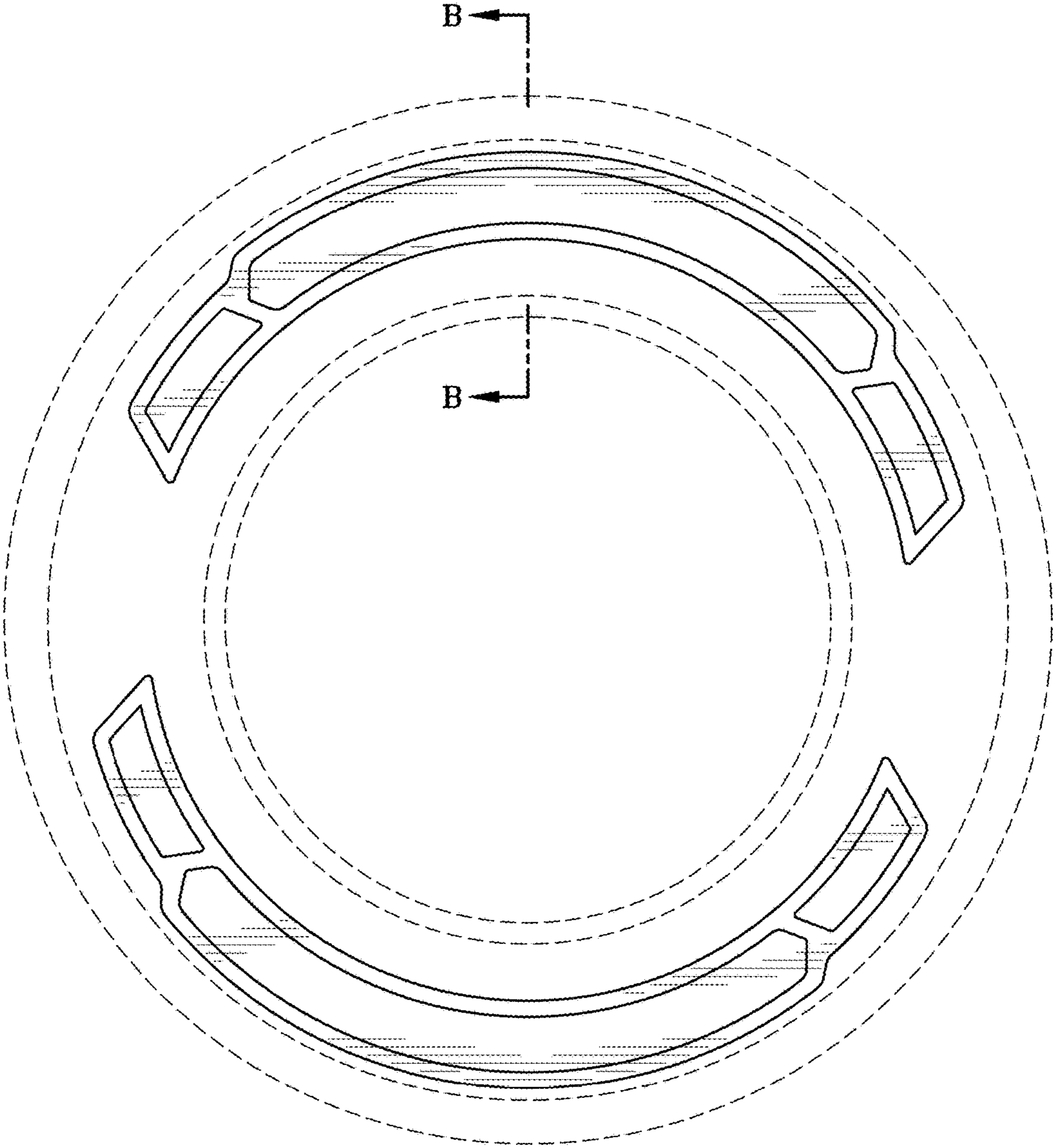

FIG.6



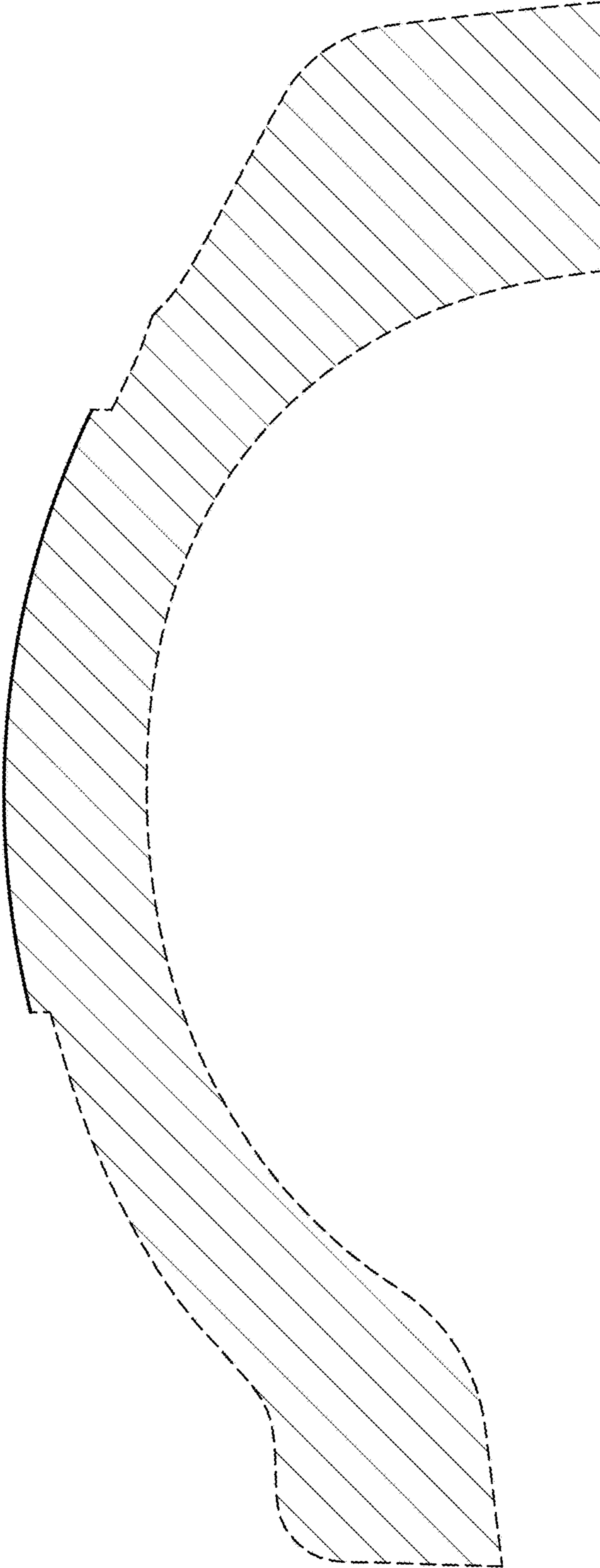

FIG. 7

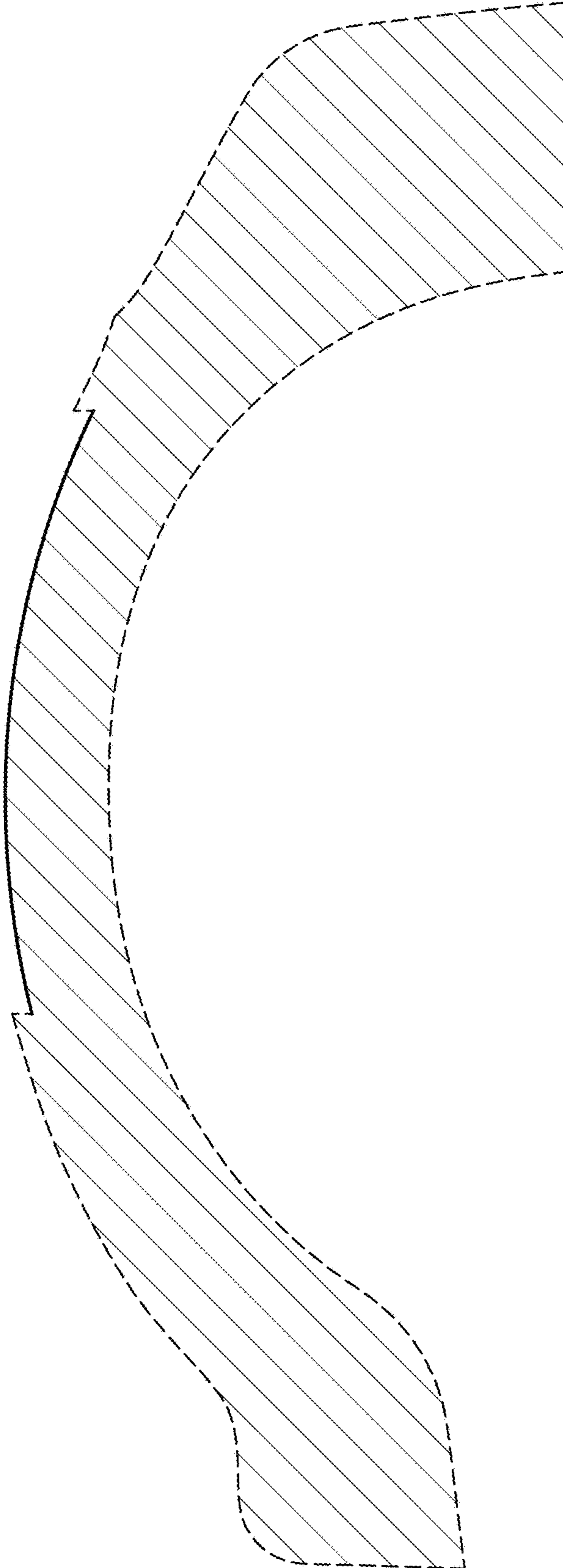

FIG. 8

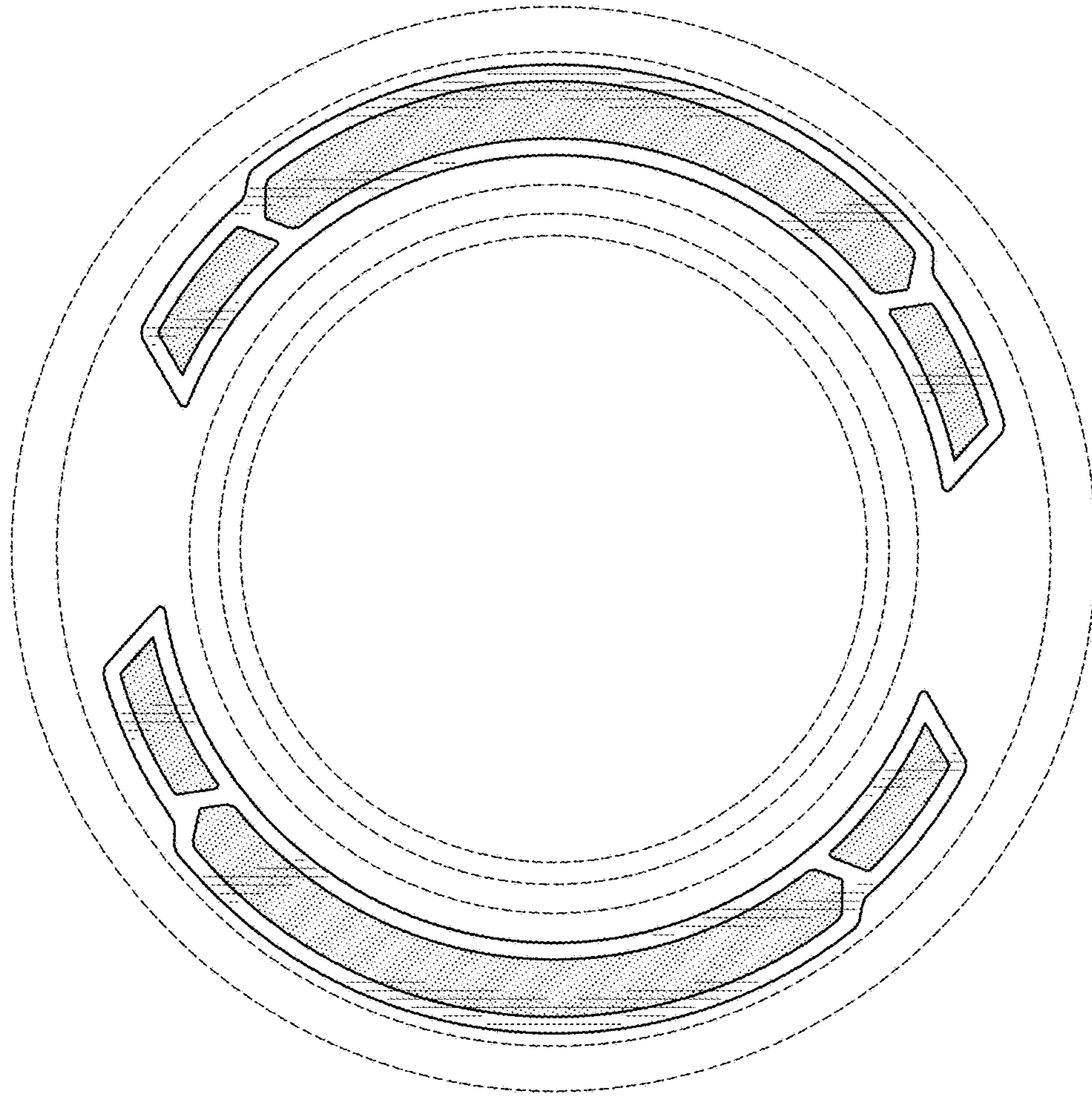

FIG. 9