



US00D798794S

(12) **United States Design Patent** (10) **Patent No.:** **US D798,794 S**
Fenny et al. (45) **Date of Patent:** **** Oct. 3, 2017**

(54) **CLOSED WING AIRCRAFT**

(71) Applicant: **Bell Helicopter Textron Inc.**, Fort Worth, TX (US)

(72) Inventors: **Carlos Alexander Fenny**, Fort Worth, TX (US); **Rohn Lee Olson**, Hurst, TX (US); **Andrew James Zahasky**, North Richland Hills, TX (US)

(73) Assignee: **BELL HELICOPTER TEXTRON INC.**, Fort Worth, TX (US)

(**) Term: **15 Years**

(21) Appl. No.: **29/564,548**

(22) Filed: **May 13, 2016**

(51) **LOC (10) Cl.** **12-07**

(52) **U.S. Cl.**
USPC **D12/328**; D21/441; D12/345

(58) **Field of Classification Search**
USPC D12/16.1, 319-324, 326-345; D21/436, D21/441, 443, 444, 446, 447, 448, 449, D21/450, 451, 452, 453

(Continued)

(56) **References Cited**

U.S. PATENT DOCUMENTS

D174,679 S * 5/1955 Cochran 244/12.1
D181,599 S * 12/1957 Nelson D12/330
(Continued)

OTHER PUBLICATIONS

Volocopter, Misc. Website images, VC400 <http://www.volocopter.com/index.php>, 13 pp. Oct. 29, 2014.

Primary Examiner — Robert M Spear
Assistant Examiner — Marissa J Cash

(74) *Attorney, Agent, or Firm* — Daniel J. Chalker; Edwin S. Flores; Chalker Flores, LLP

(57) **CLAIM**

The ornamental design for a closed wing aircraft, as shown and described.

DESCRIPTION

This application is related to the following application filed concurrently herewith: “Ring Wing and Spokes for Closed Wing Aircraft” and “Sinusoidal Circular Wing and Spokes for a Closed Wing Aircraft”.

FIG. 1 is a perspective view of a closed wing aircraft having equally spaced winglets on the fuselage in which all the rotors are deployed;

FIG. 2 is a front elevation view thereof;

FIG. 3 is a rear elevation view thereof;

FIG. 4 is a right side elevation view thereof;

FIG. 5 is a left side elevation view thereof;

FIG. 6 is a top plan view thereof;

FIG. 7 is a bottom plan view thereof;

FIG. 8 is a perspective view of a closed wing aircraft having equally spaced winglets on the fuselage in which the rotors on the spokes are deployed and the rotors on the closed wing are folded forward;

FIG. 9 is a front elevation view thereof;

FIG. 10 is a rear elevation view thereof;

FIG. 11 is a right side elevation view thereof;

FIG. 12 is a left side elevation view thereof;

FIG. 13 is a top plan view thereof;

FIG. 14 is a bottom plan view thereof;

FIG. 15 is a perspective view of a closed wing aircraft having unequally spaced winglets on the fuselage in which all the rotors are deployed;

FIG. 16 is a front elevation view thereof;

FIG. 17 is a rear elevation view thereof;

FIG. 18 is a right side elevation view thereof;

FIG. 19 is a left side elevation view thereof;

FIG. 20 is a top plan view thereof;

FIG. 21 is a bottom plan view thereof;

FIG. 22 is a perspective view of a closed wing aircraft having unequally spaced winglets on the fuselage in which the rotors on the spokes are deployed and the rotors on the closed wing are folded forward;

FIG. 23 is a front elevation view thereof;

FIG. 24 is a rear elevation view thereof;

(Continued)

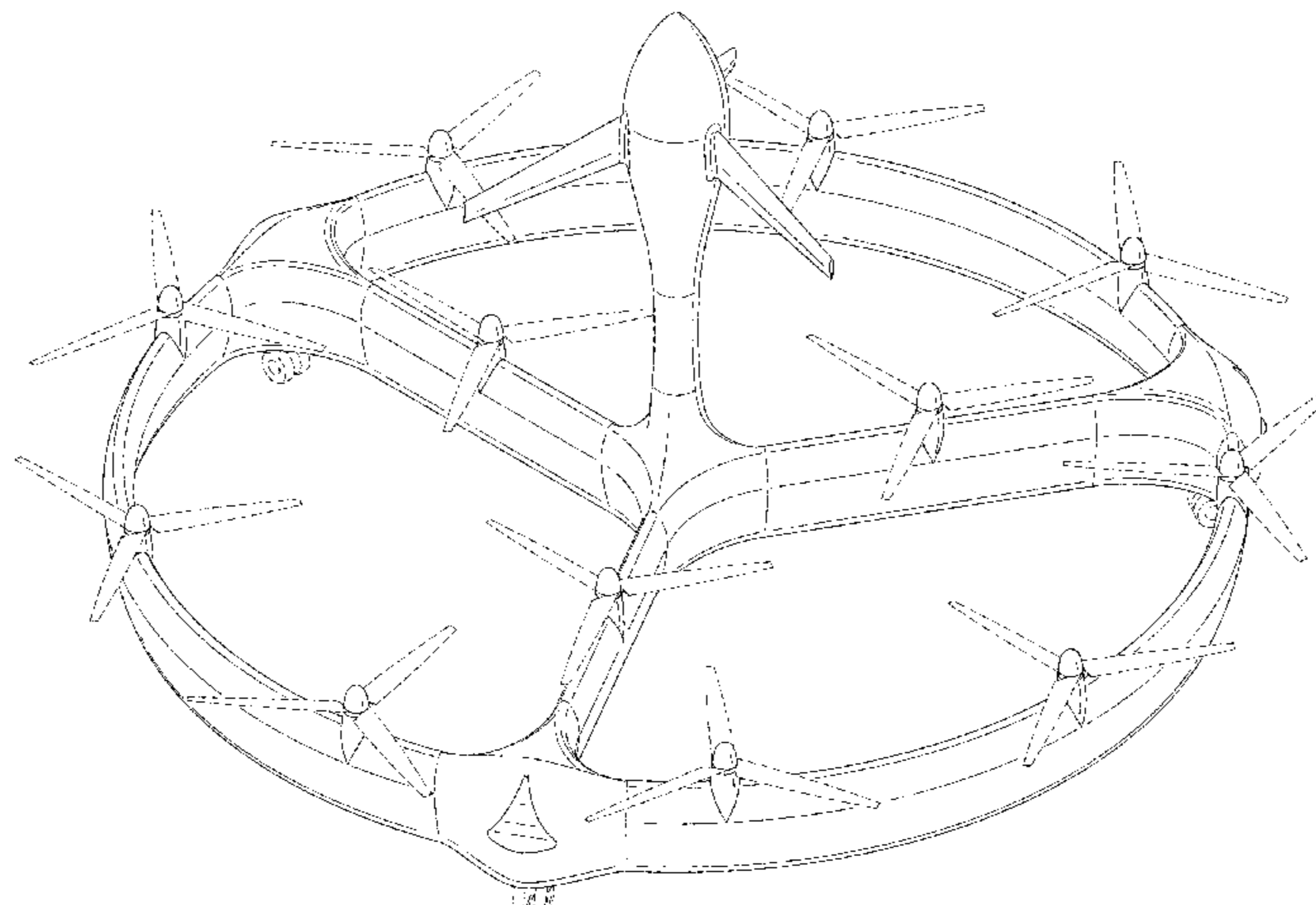

FIG. 25 is a right side elevation view thereof;
 FIG. 26 is a left side elevation view thereof;
 FIG. 27 is a top plan view thereof; and,
 FIG. 28 is a bottom plan view thereof.
 In the drawings, the evenly-spaced broken line showing of
 the rotors and landing gear depicts environment and forms
 no part of the claim; the dash-dot-dot-dash lines represent
 boundaries of the claimed design and form no part thereof.

1 Claim, 28 Drawing Sheets

(58) **Field of Classification Search**

CPC B64C 1/062; B64C 39/024; B64C 27/08;
 B64C 29/00; B64C 39/00; B64C 23/00;
 B64C 27/20

See application file for complete search history.

(56) **References Cited**

U.S. PATENT DOCUMENTS

D185,870 S * 8/1959 Apostolescu D21/452
 3,005,603 A 10/1961 Gaskins
 D193,245 S * 7/1962 Knox D21/444
 3,082,977 A 3/1963 Arlin
 D197,447 S * 2/1964 Friedrich 244/12.2
 D213,708 S * 4/1969 Blumenthal D21/441
 D214,577 S * 7/1969 Mueller 446/48
 3,640,489 A 2/1972 Jaeger
 3,834,654 A 9/1974 Miranda
 D241,565 S * 9/1976 Molenaar 446/48
 D314,549 S 2/1991 Myers
 D324,890 S * 3/1992 Smiel D21/441
 5,150,857 A * 9/1992 Moffitt B64C 27/20
 244/12.2
 5,178,344 A * 1/1993 Dlouhy B64C 27/20
 244/12.2

5,305,970 A * 4/1994 Porter B64G 1/1078
 244/135 R
 5,595,358 A 1/1997 Demidov et al.
 6,382,560 B1 5/2002 Ow
 6,607,162 B2 8/2003 Warsop et al.
 6,688,936 B2 * 2/2004 Davis A63H 27/04
 446/175
 6,921,313 B2 * 7/2005 Yu A63H 33/22
 446/39
 D543,928 S * 6/2007 Sanders, Jr. B64C 27/12
 D12/319
 7,370,828 B2 5/2008 Stephens
 7,658,348 B1 2/2010 Braly
 7,794,302 B2 * 9/2010 Davis A63H 27/12
 446/454
 D640,757 S * 6/2011 Cheng D21/451
 8,083,173 B2 * 12/2011 Arlton B64C 39/024
 244/17.23
 D664,214 S * 7/2012 Yuen D21/441
 D679,339 S * 4/2013 Genovese D12/16.1
 D679,340 S * 4/2013 Genovese D12/16.1
 8,408,489 B2 4/2013 Gosling
 D740,892 S * 10/2015 Chen D21/444
 D776,569 S * 1/2017 Baruchin D12/16.1
 D776,570 S * 1/2017 Baruchin D12/16.1
 D780,665 S * 3/2017 Blincow D12/320
 2002/0142699 A1 * 10/2002 Davis A63H 27/12
 446/37
 2007/0215746 A1 9/2007 Rieken et al.
 2010/0025526 A1 * 2/2010 Lawrence B64C 39/024
 244/17.23
 2015/0108280 A1 * 4/2015 Willard, Jr. B64G 1/46
 244/171.9
 2016/0170416 A1 * 6/2016 Chen B64C 27/08
 701/8
 2016/0229530 A1 * 8/2016 Welsh B64C 39/024
 2017/0015417 A1 * 1/2017 Bishop B64C 27/20
 2017/0029091 A1 * 2/2017 Linch B64C 11/001

* cited by examiner

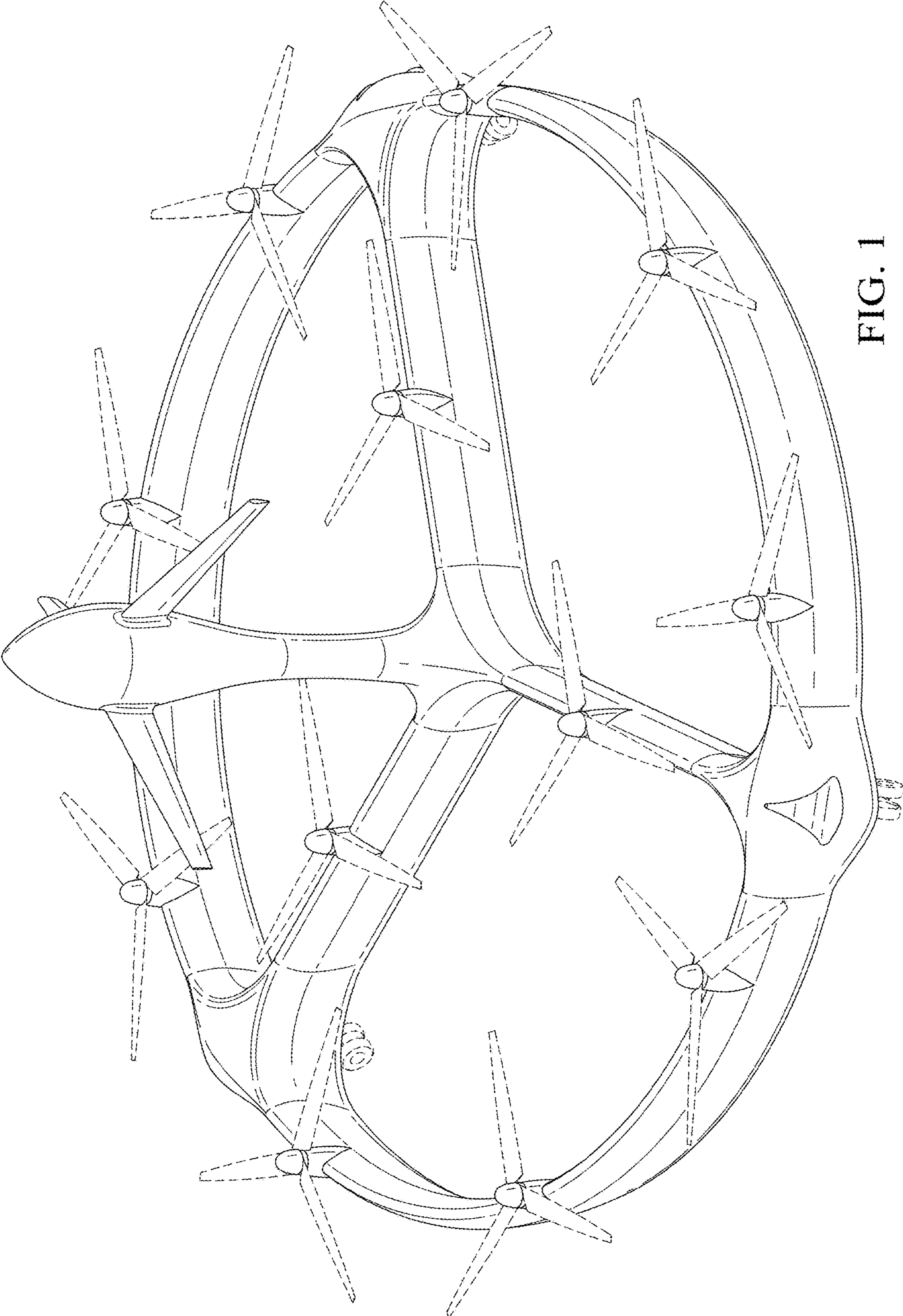

FIG. 1

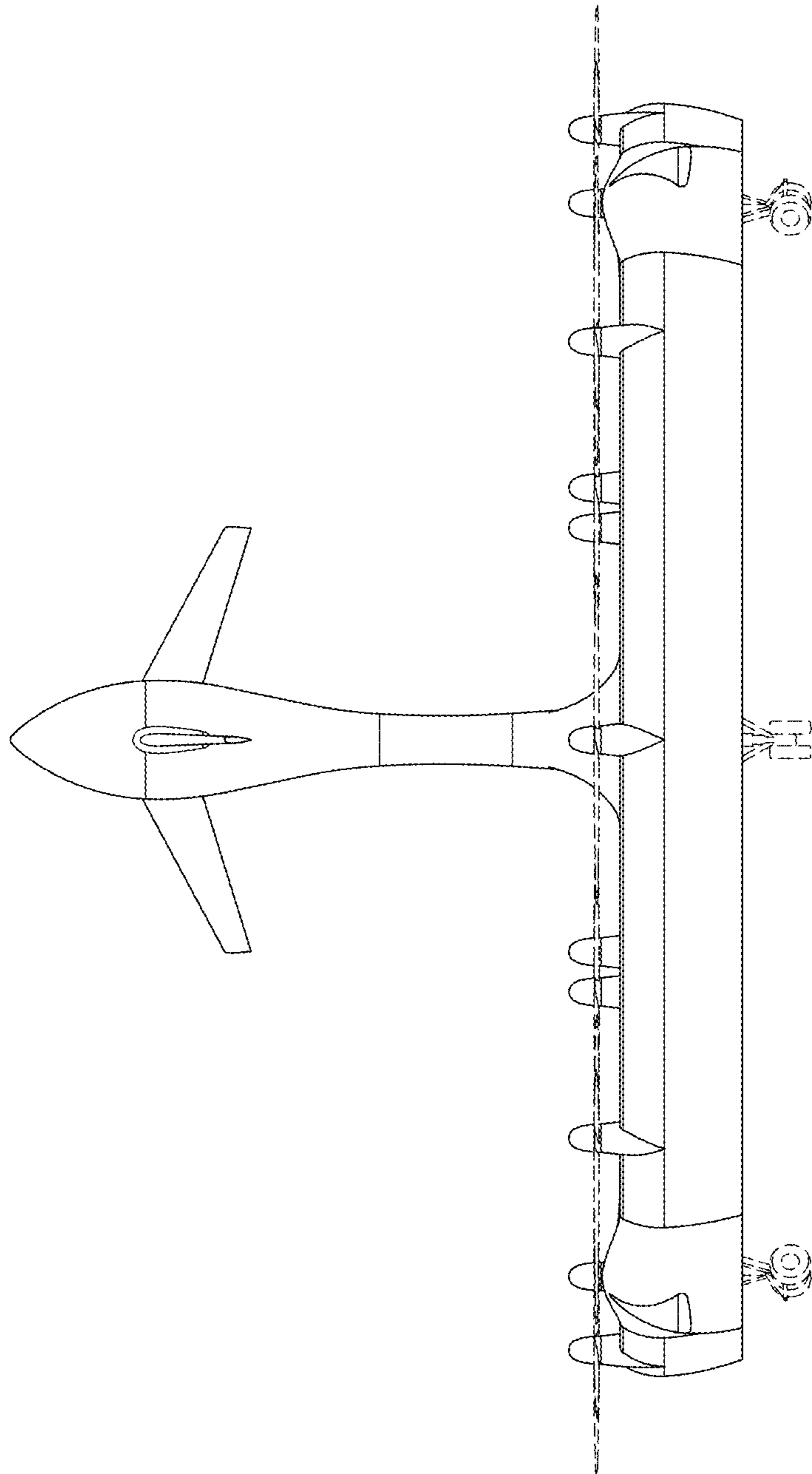

FIG. 2

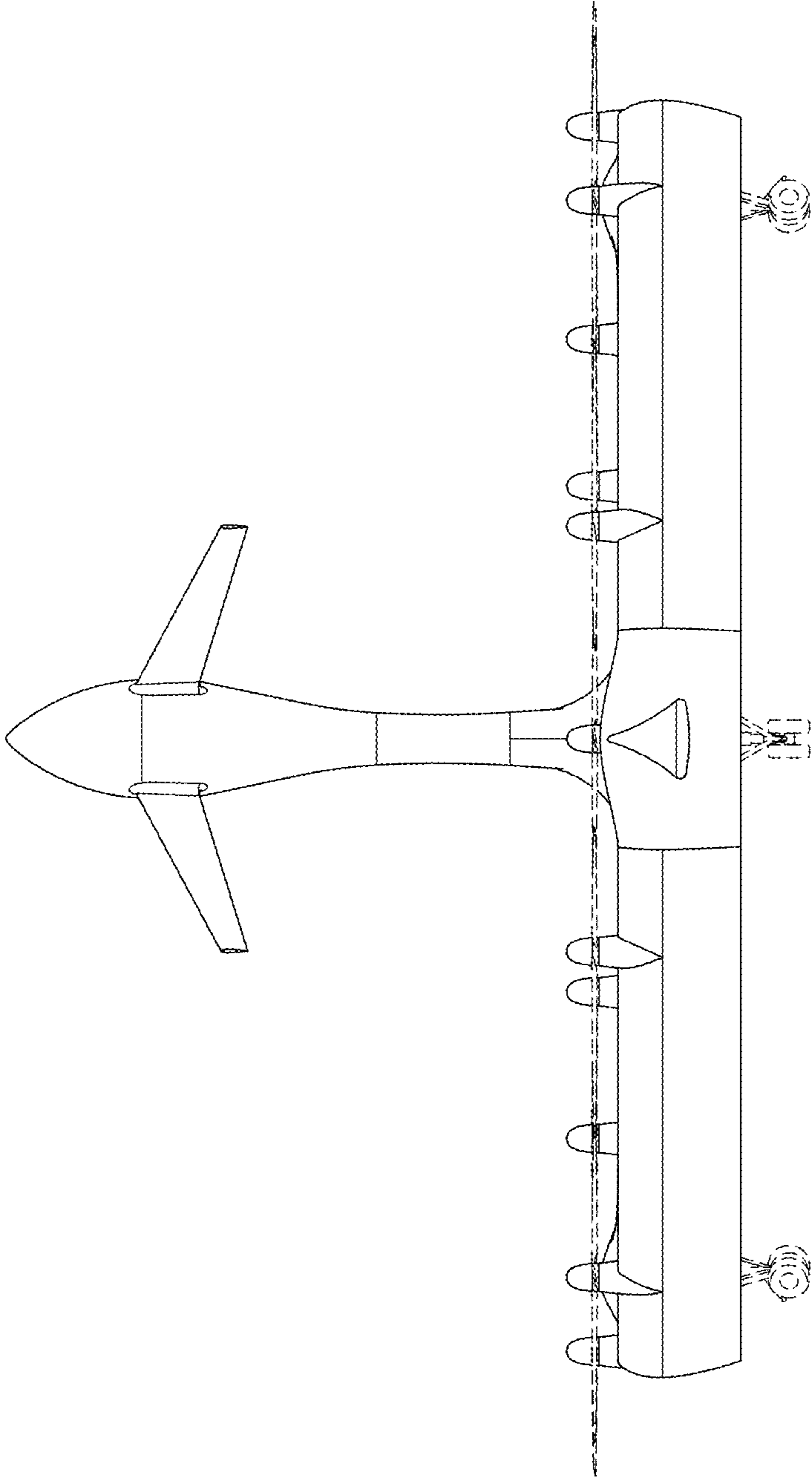

FIG. 3

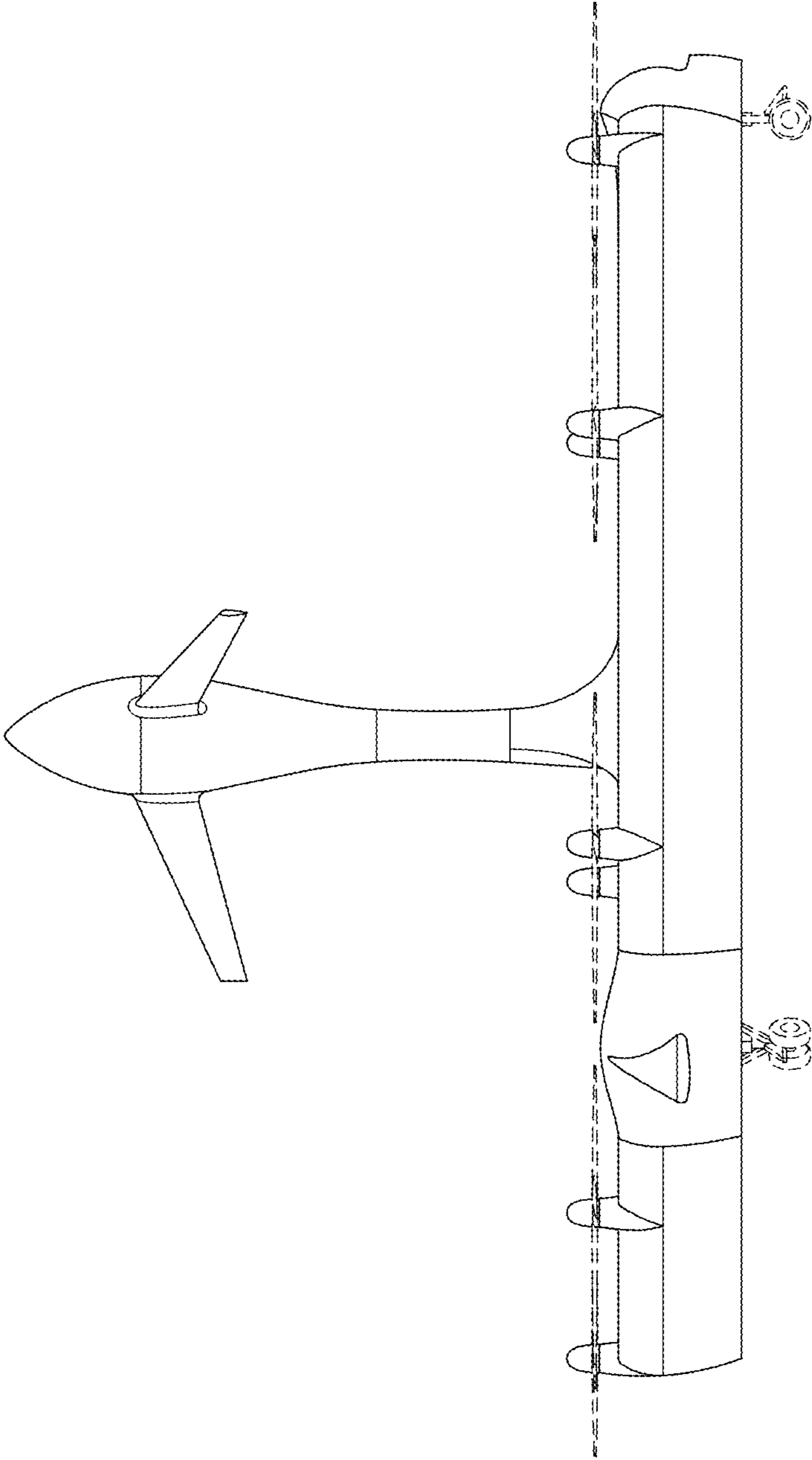

FIG. 4

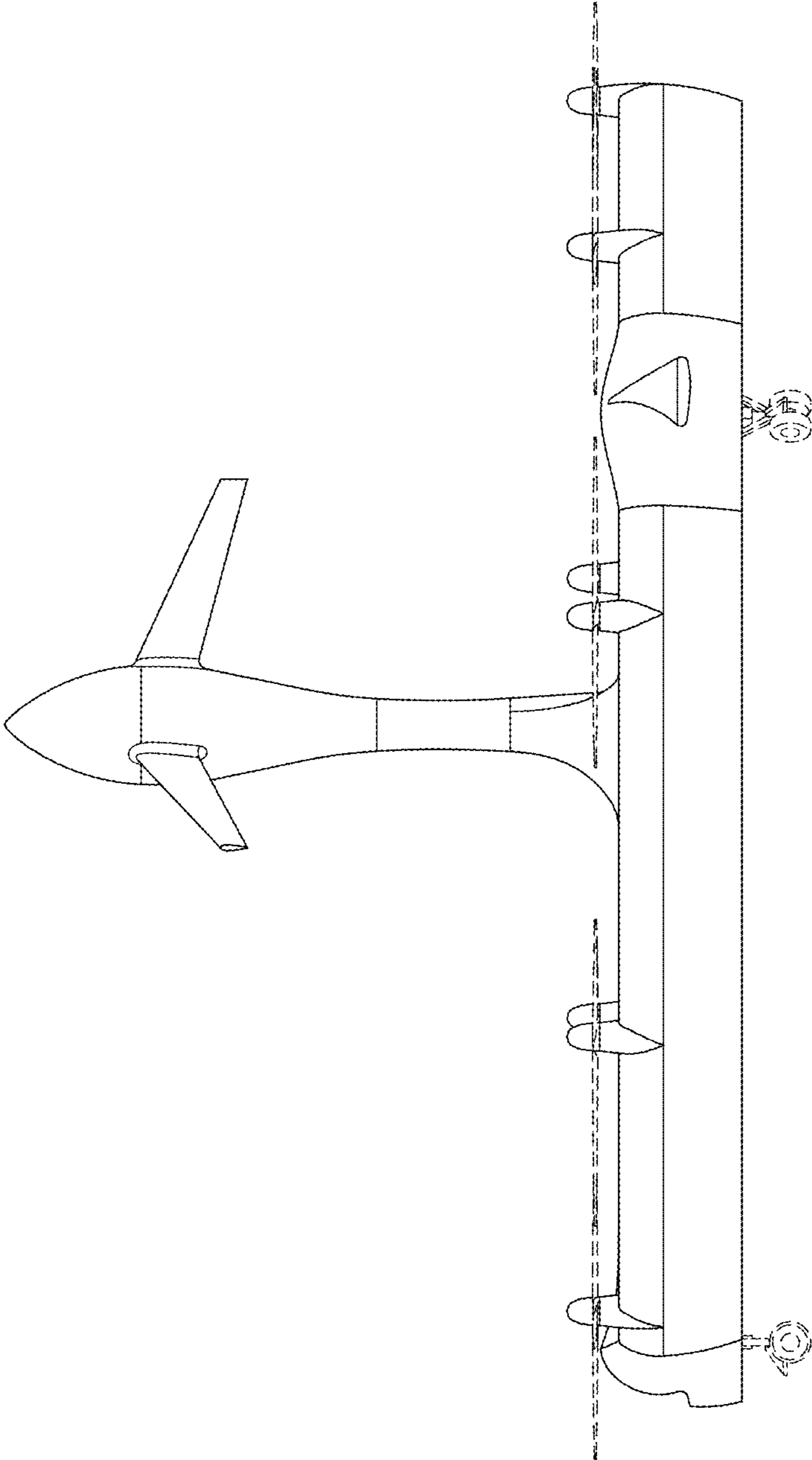

FIG. 5

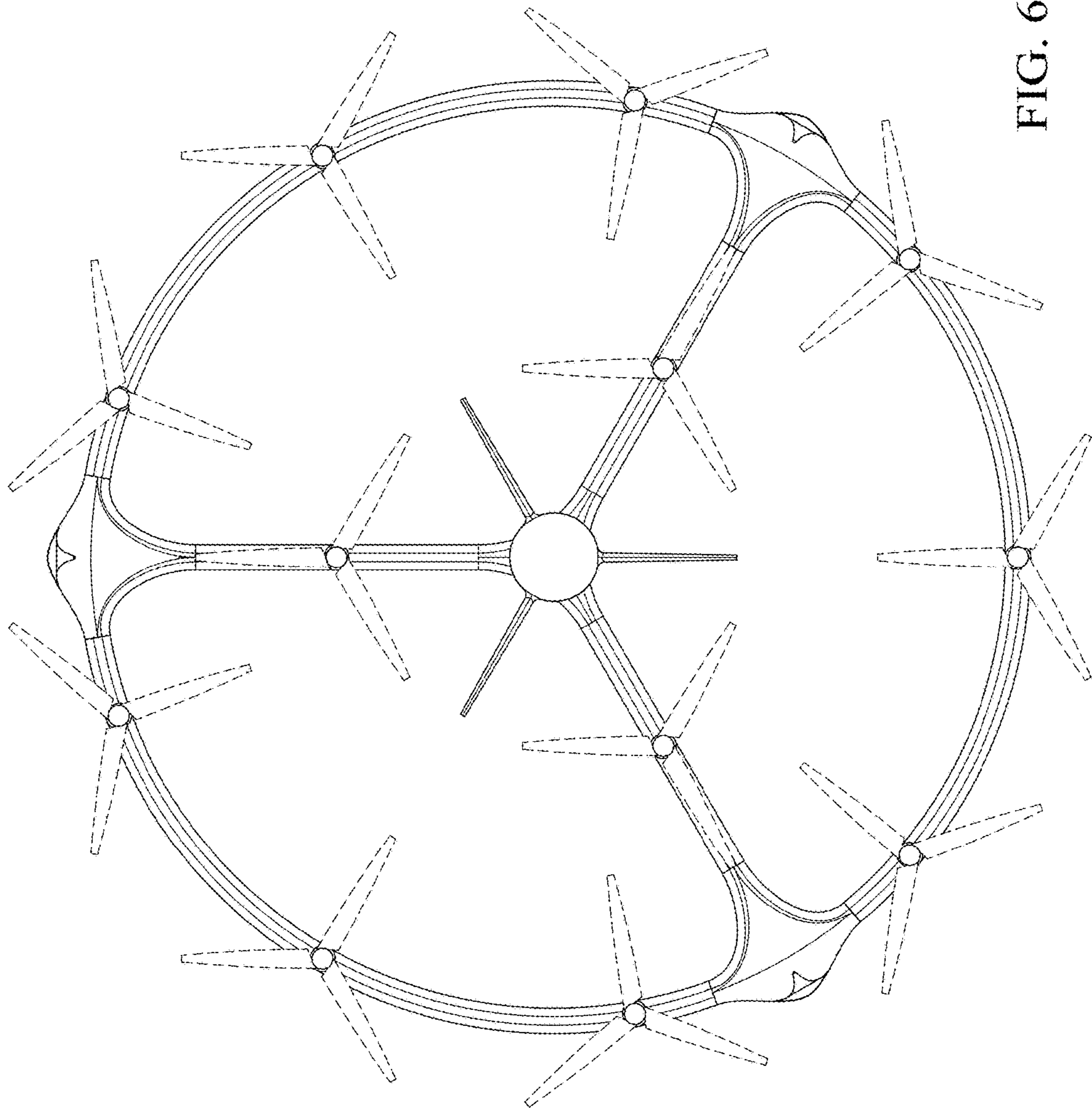

FIG. 6

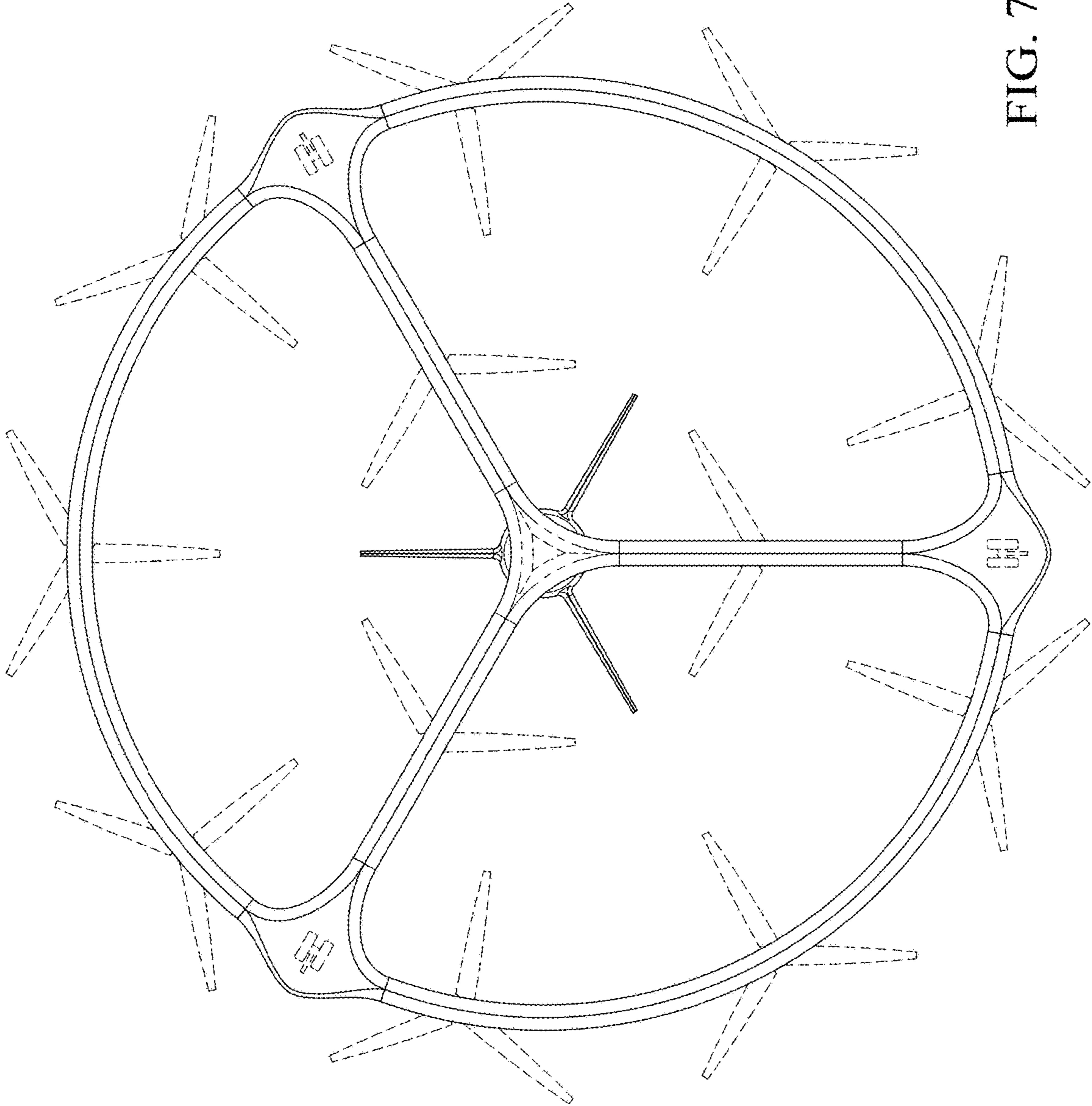

FIG. 7

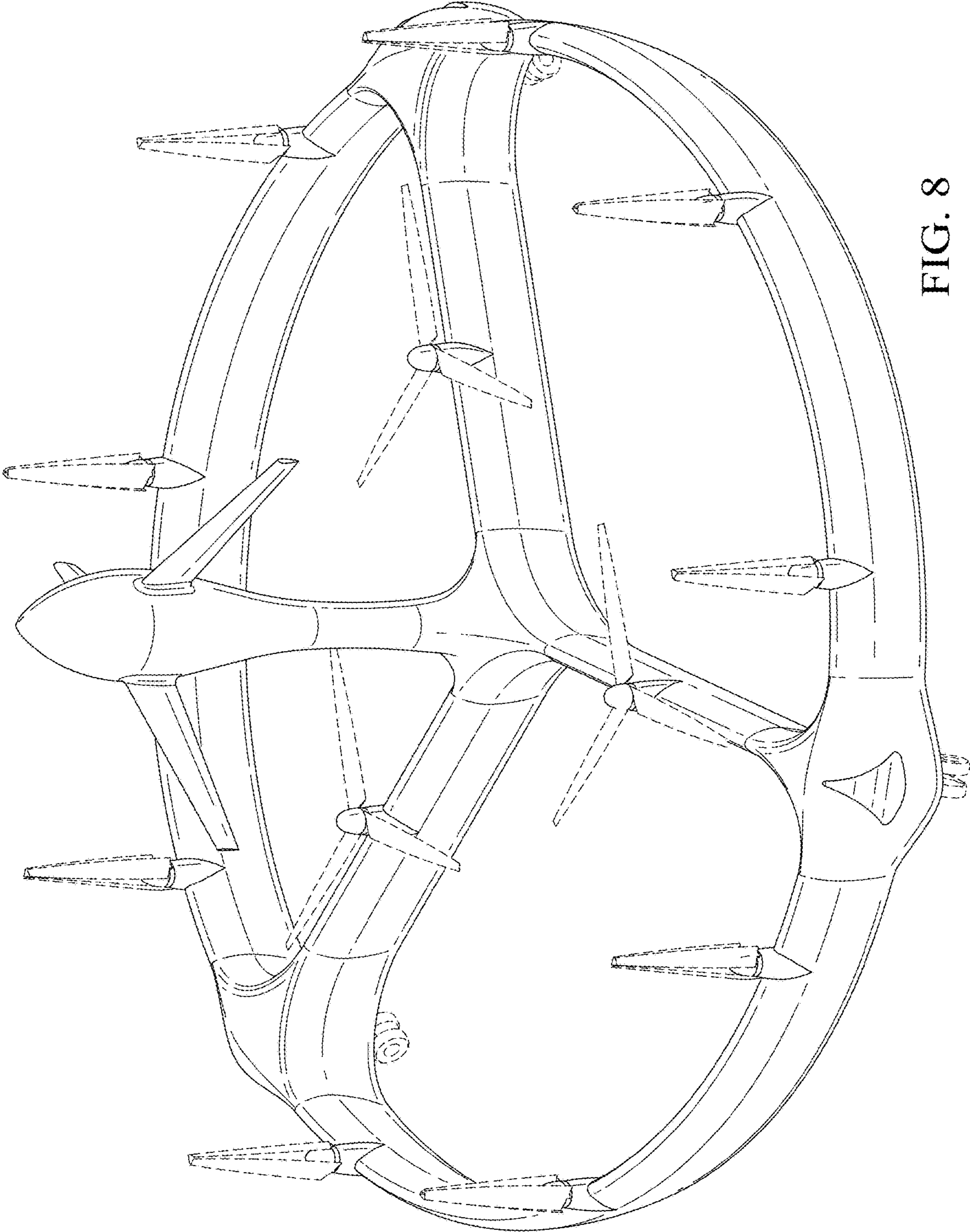

FIG. 8

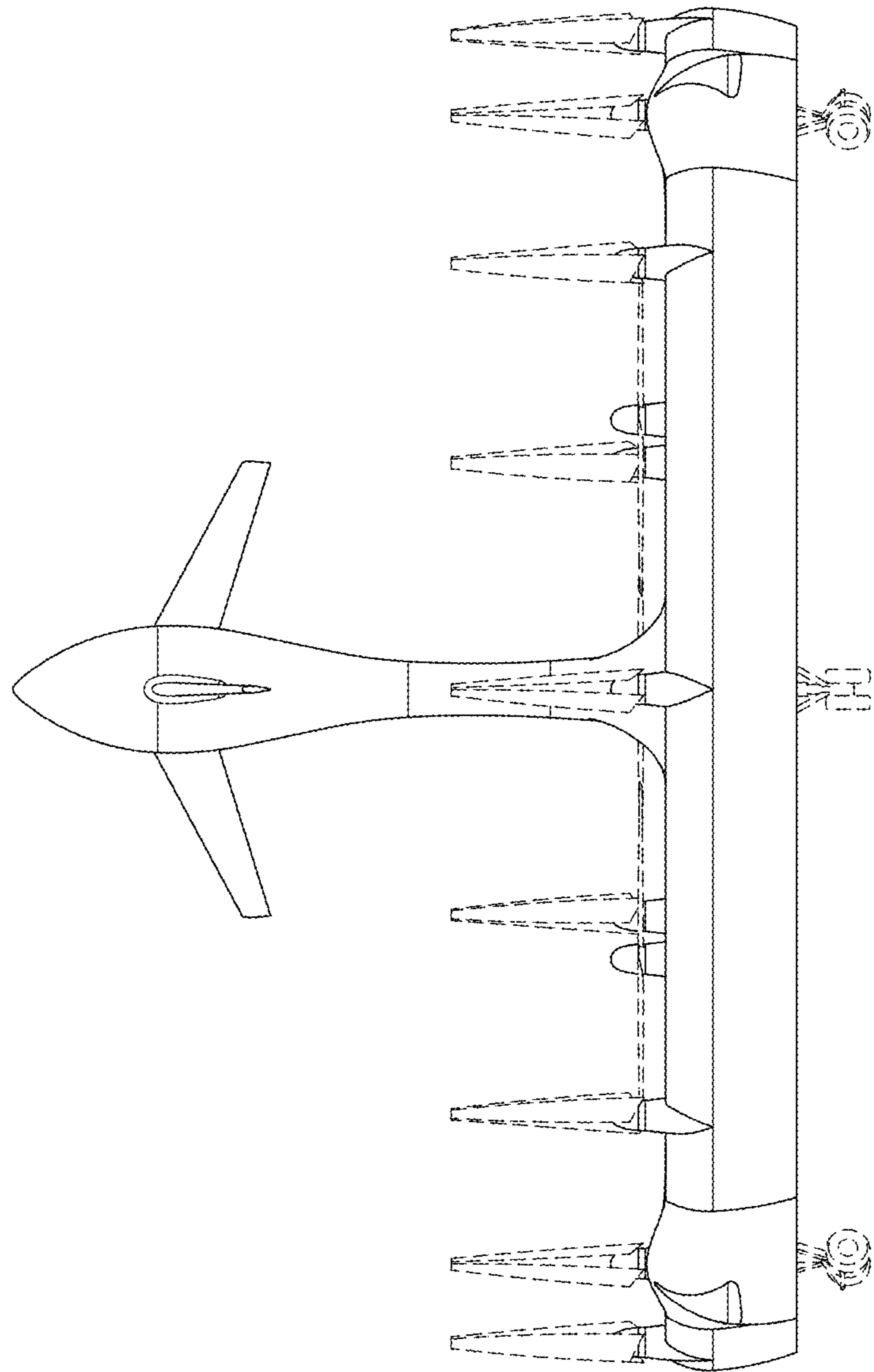

FIG. 9

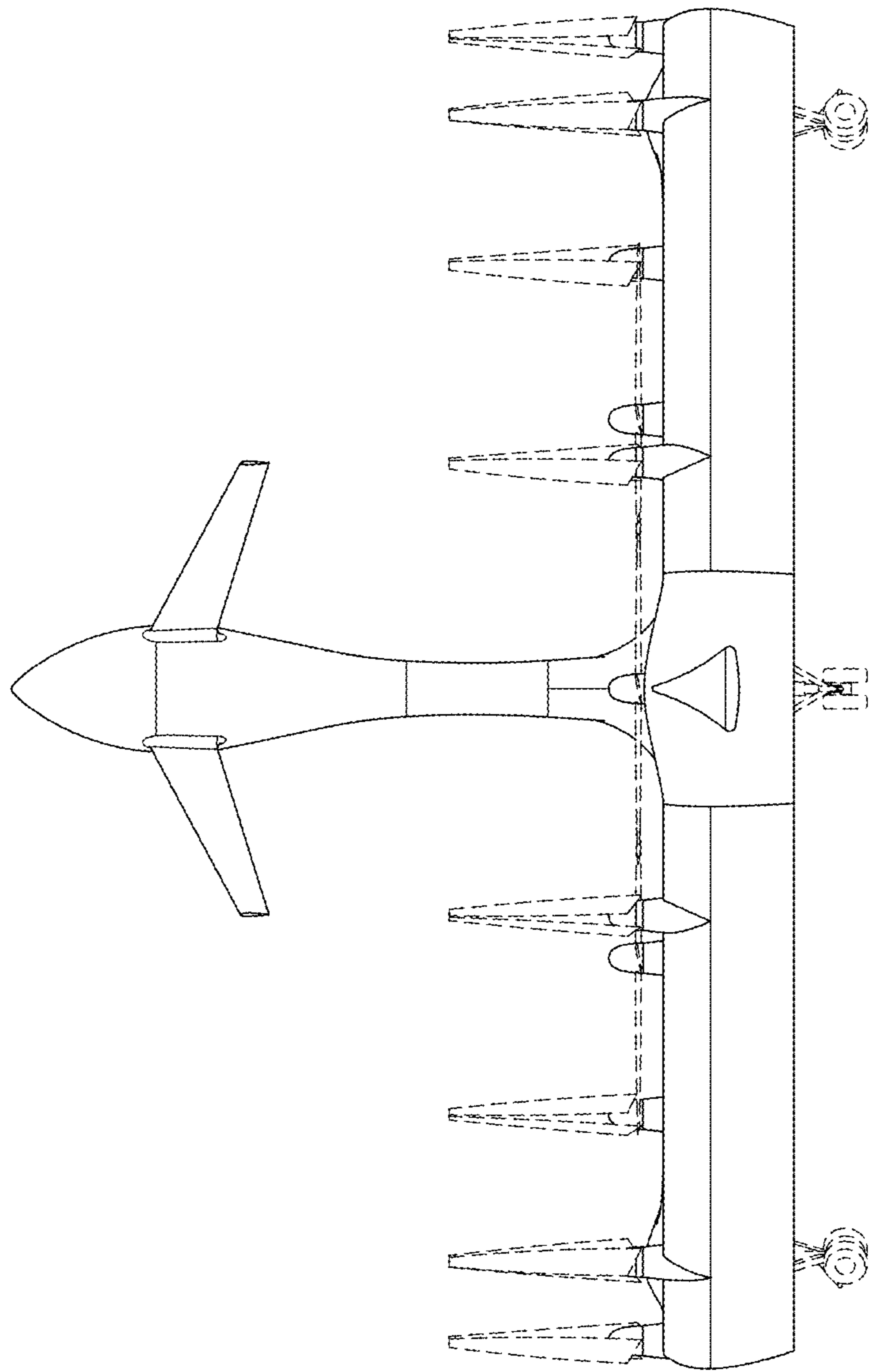

FIG. 10

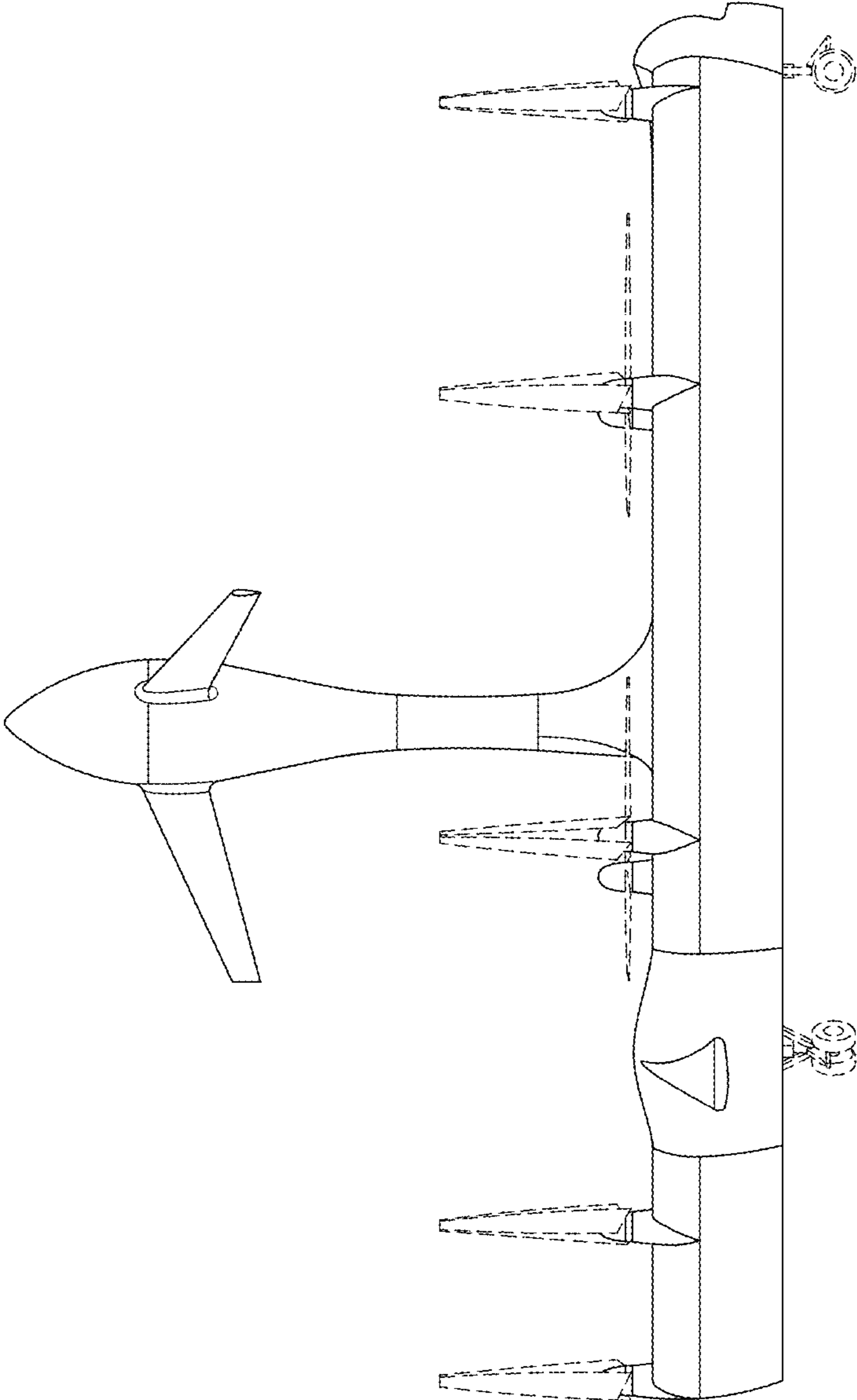

FIG. 11

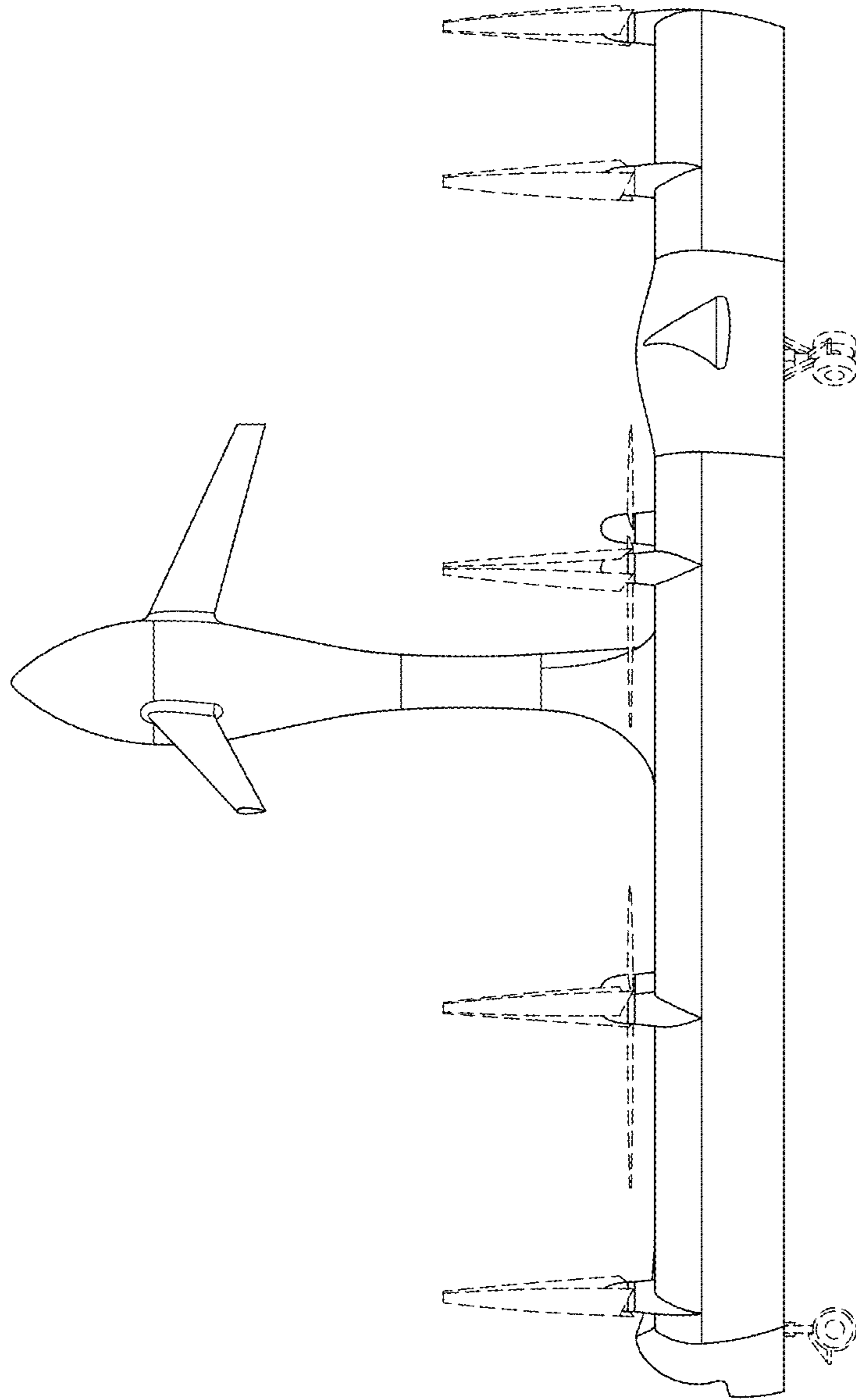

FIG. 12

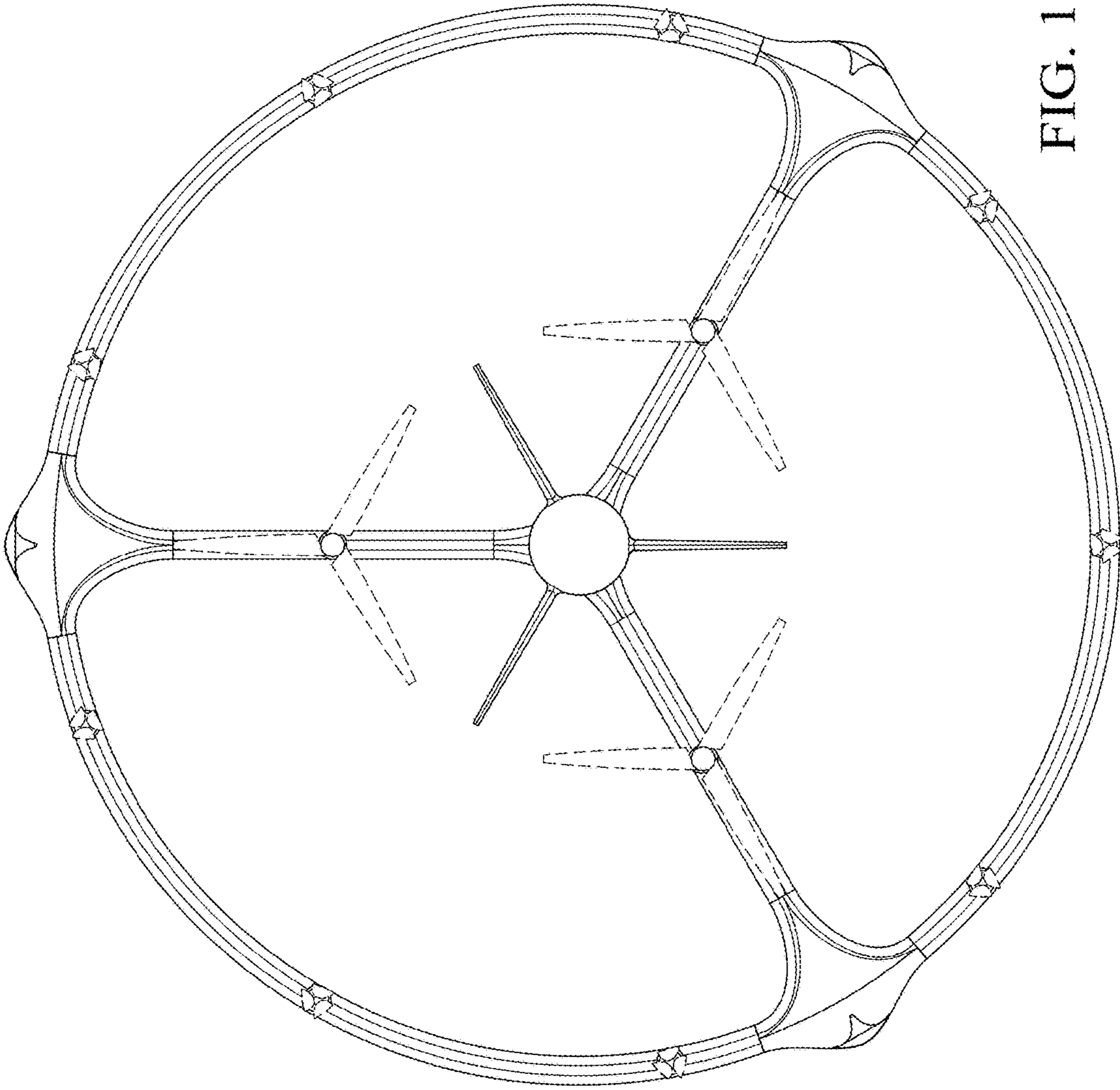

FIG. 13

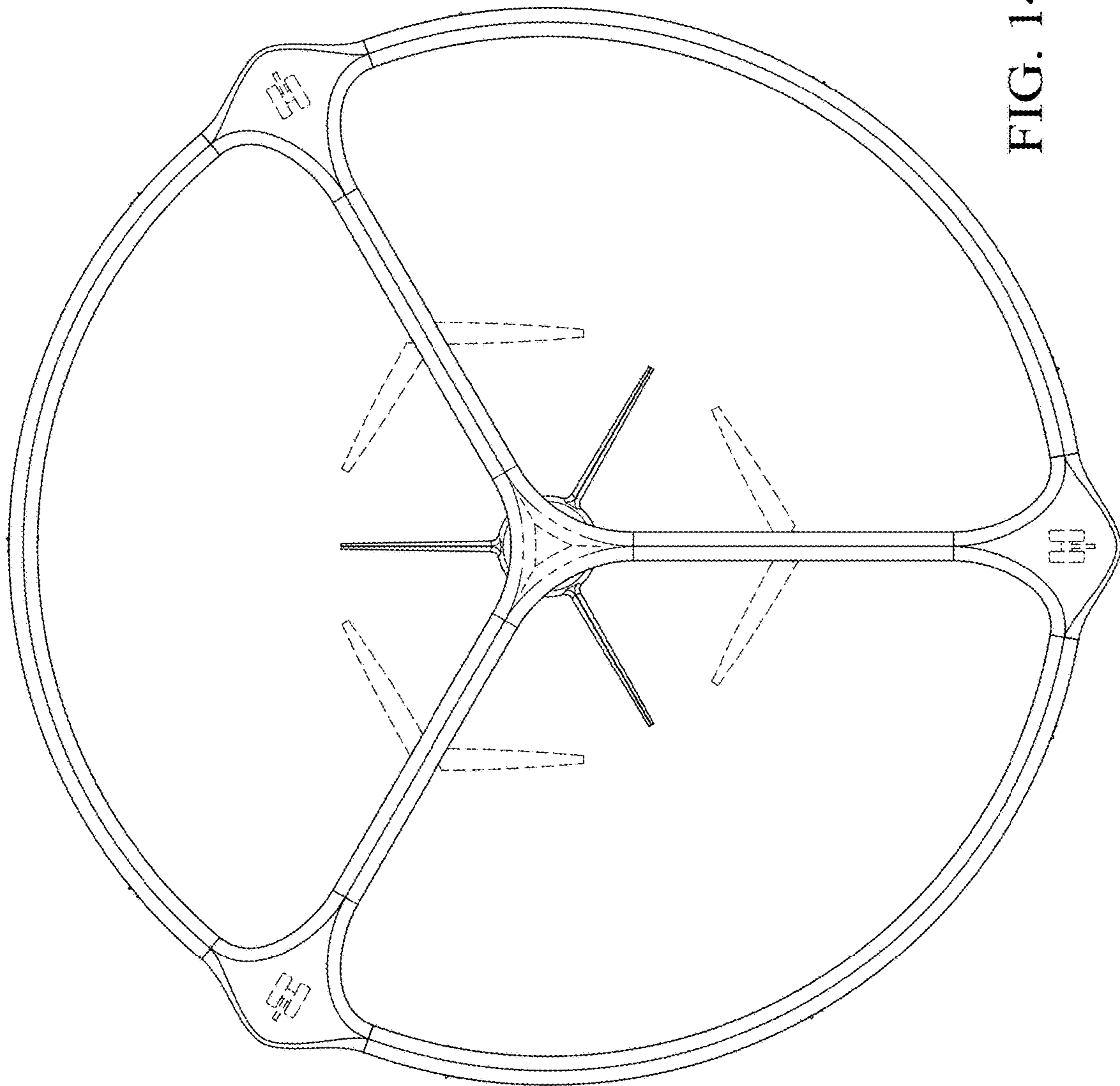

FIG. 14

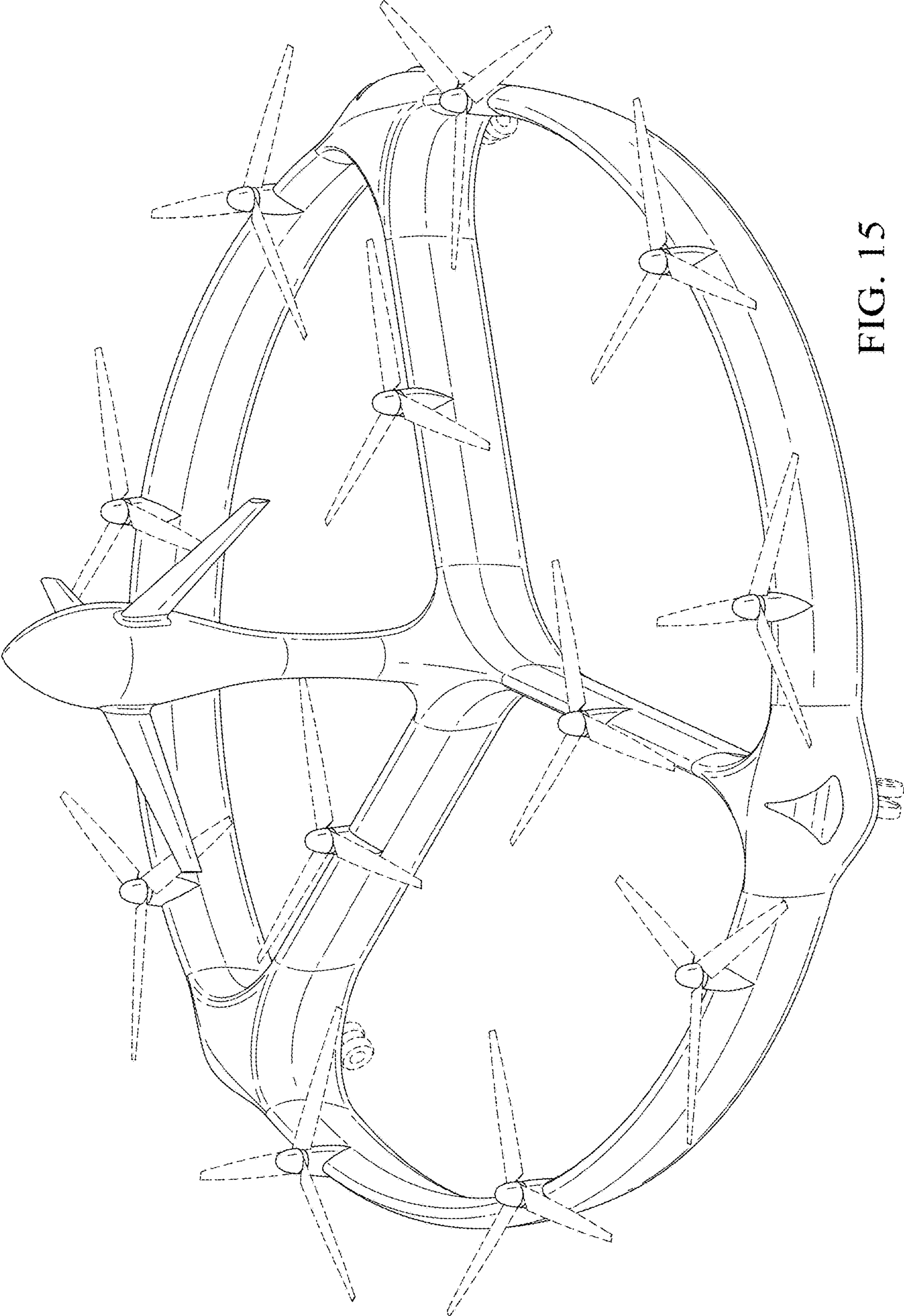

FIG. 15

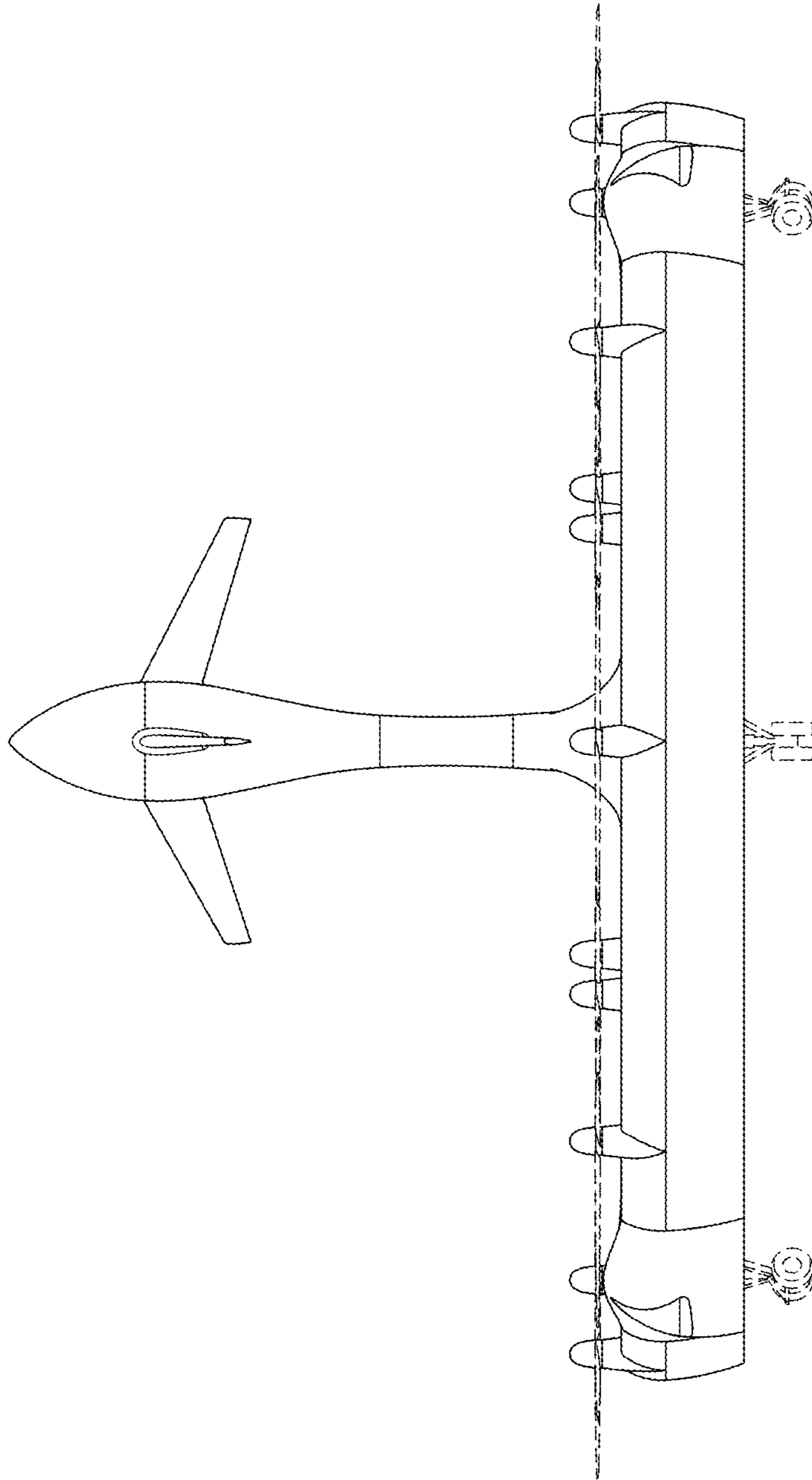

FIG. 16

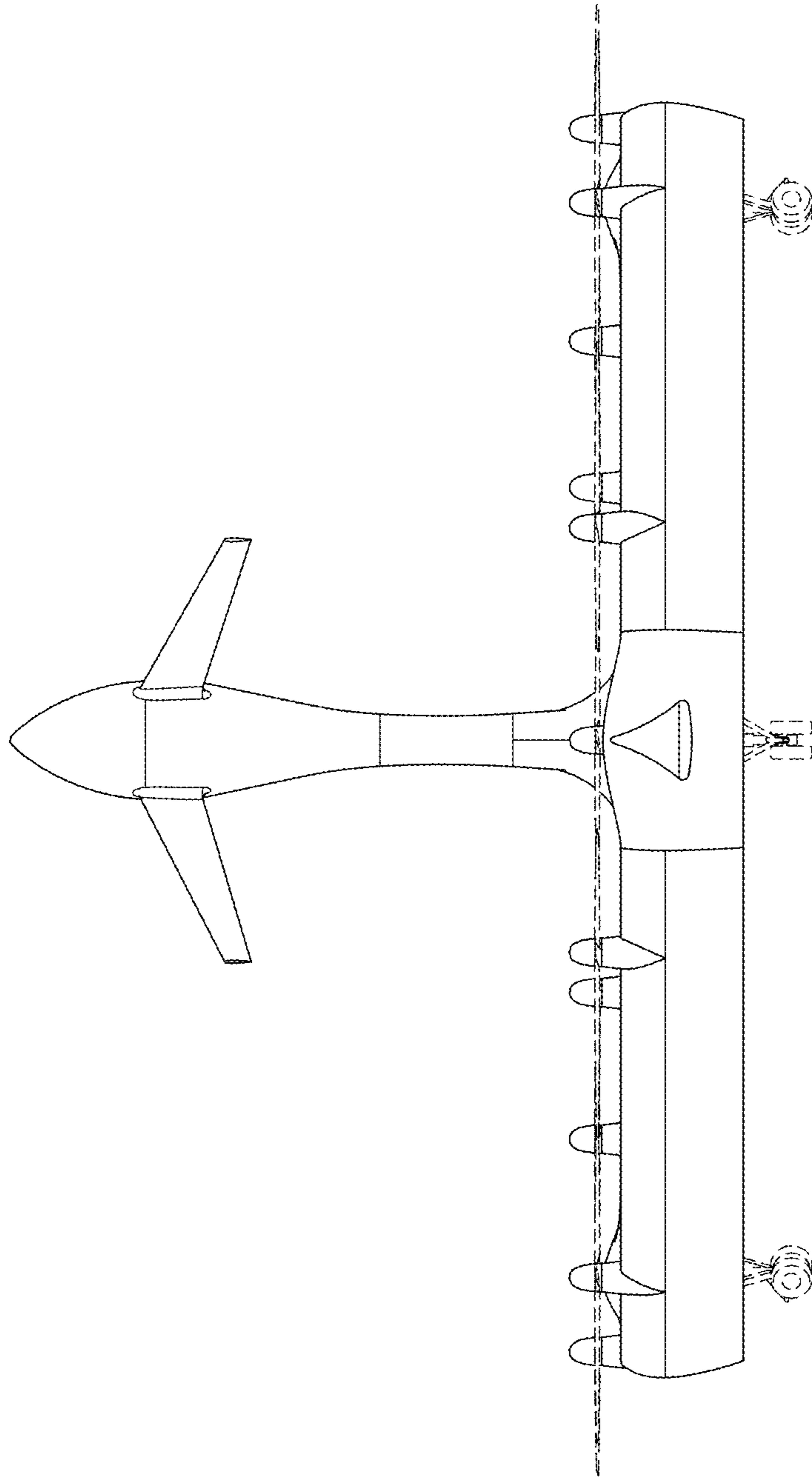

FIG. 17

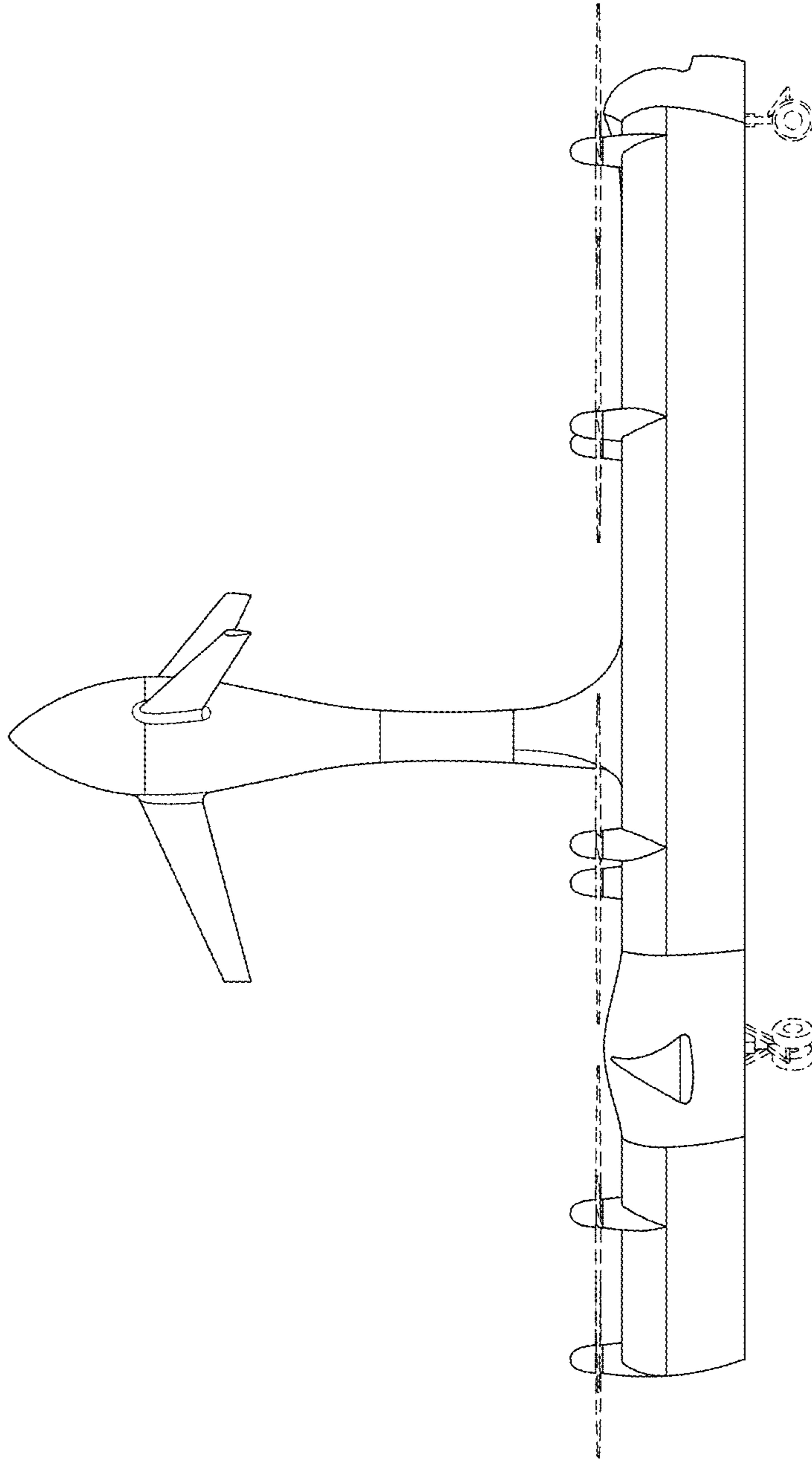

FIG. 18

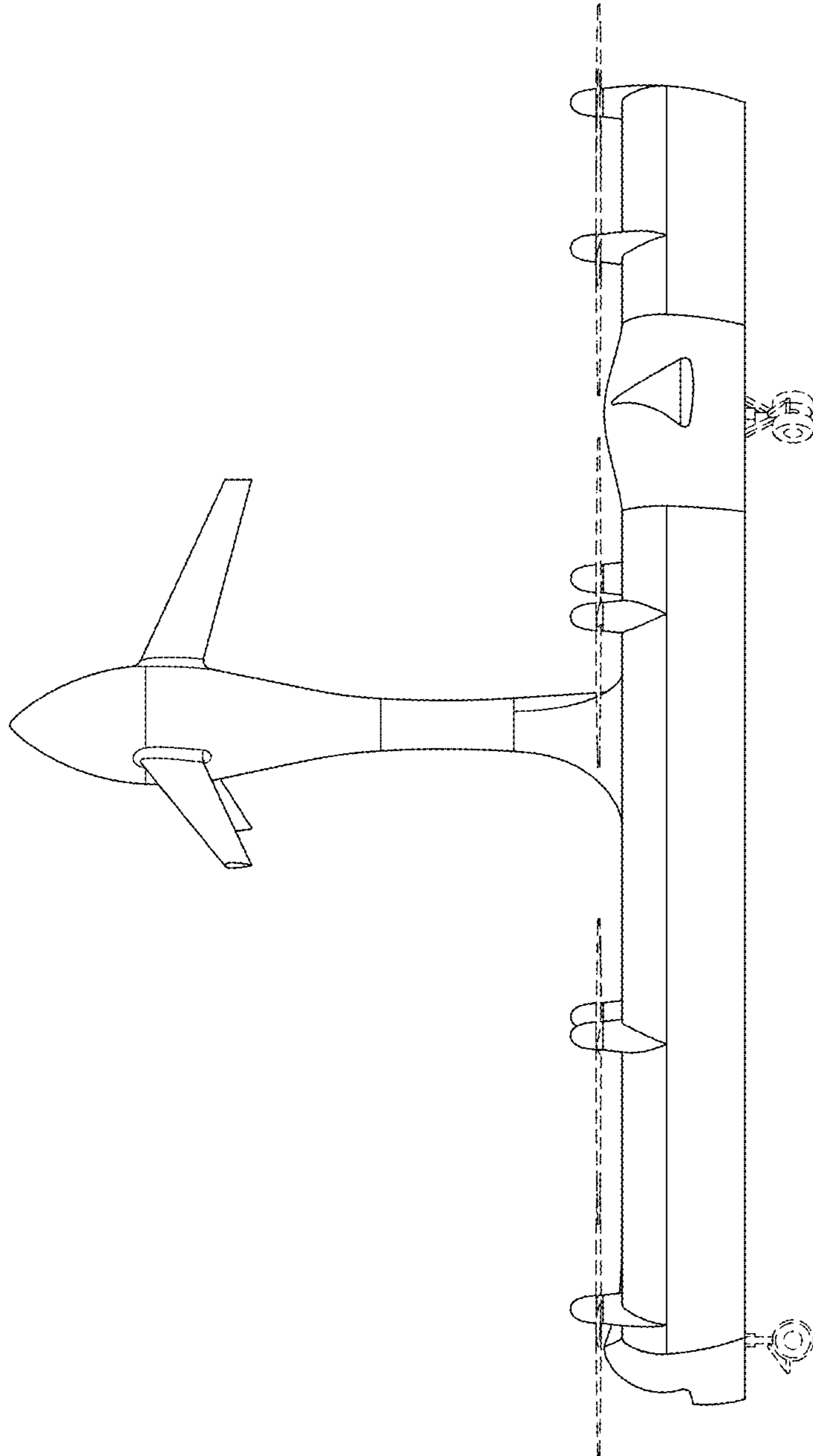

FIG. 19

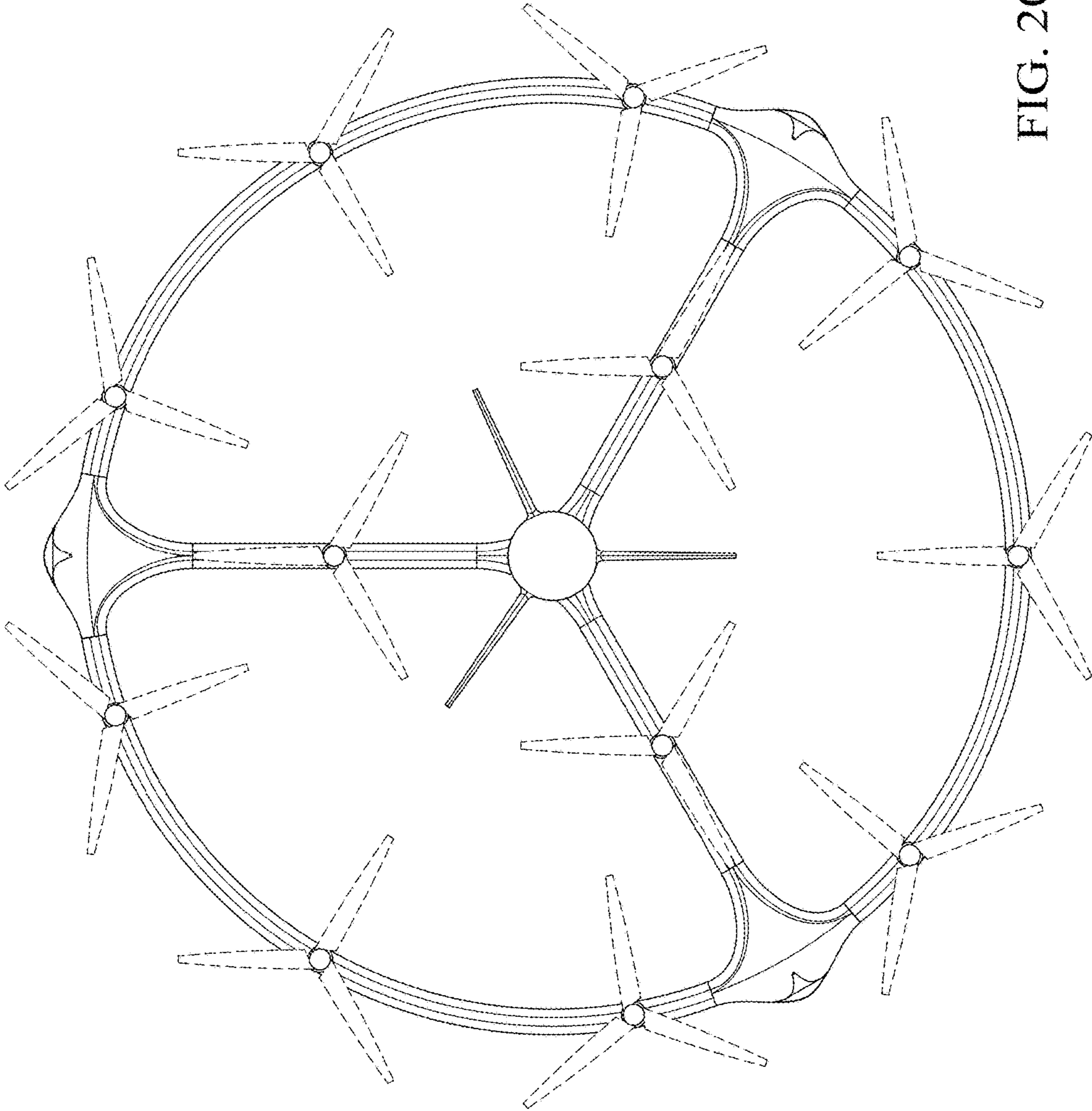

FIG. 20

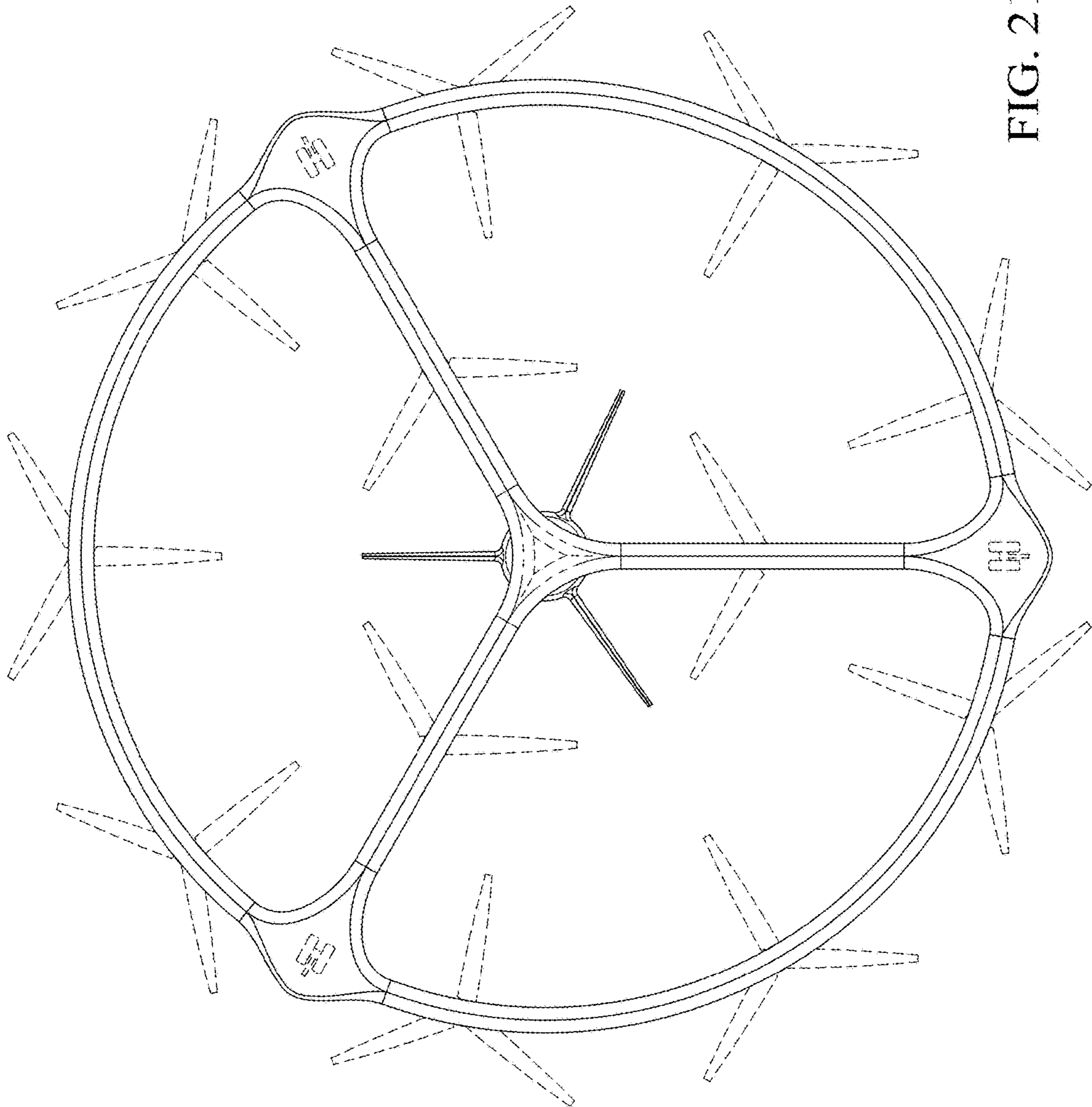

FIG. 21

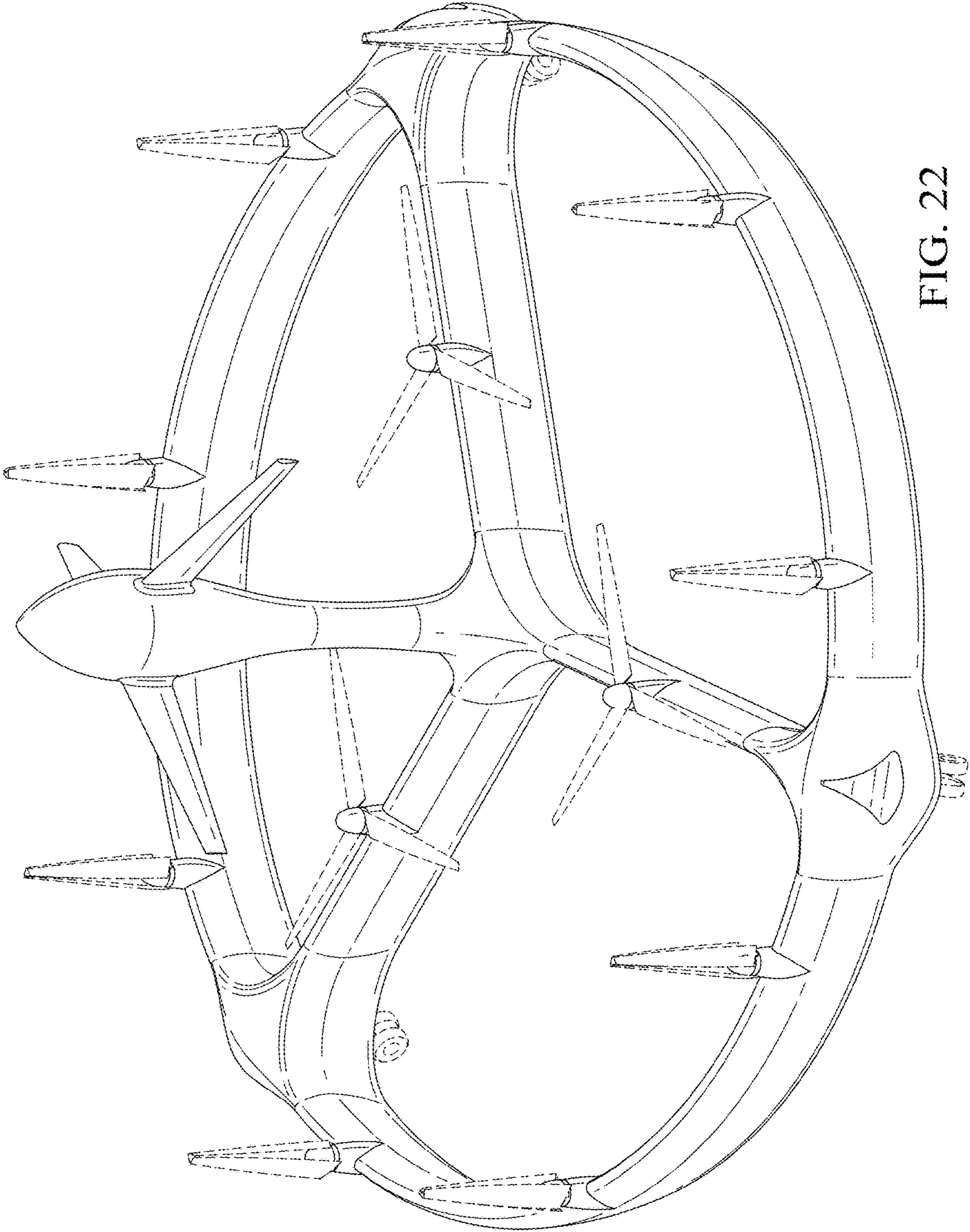

FIG. 22

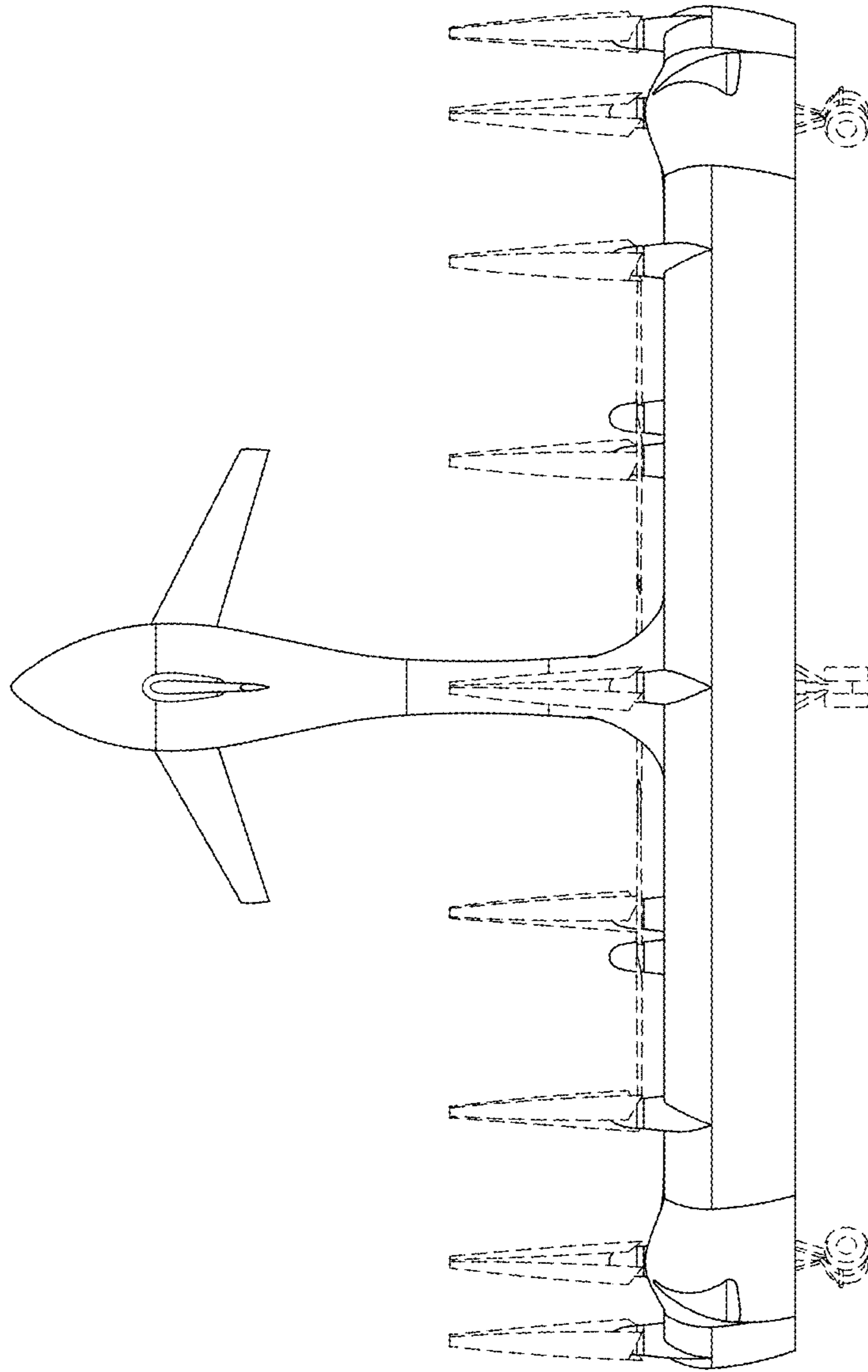

FIG. 23

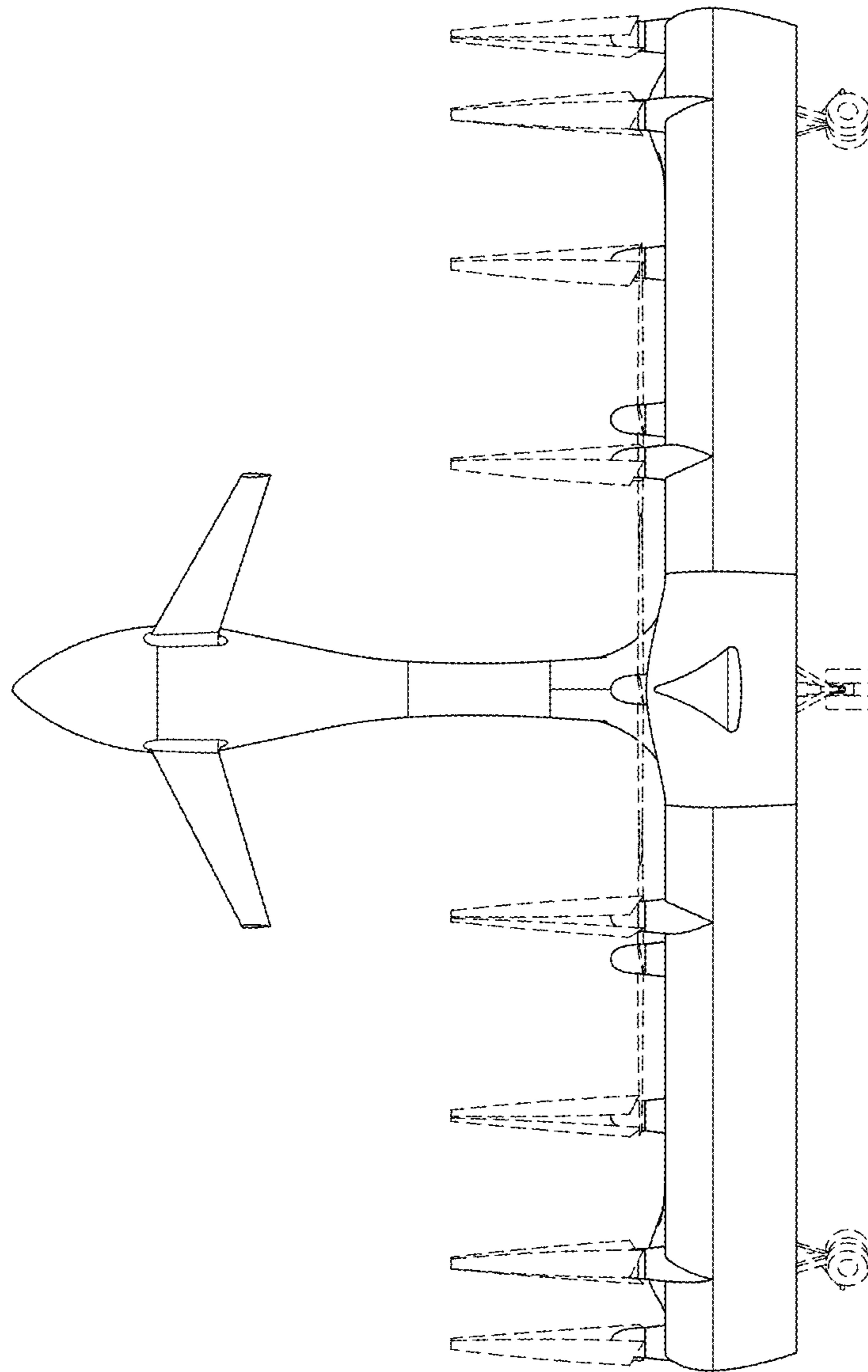

FIG. 24

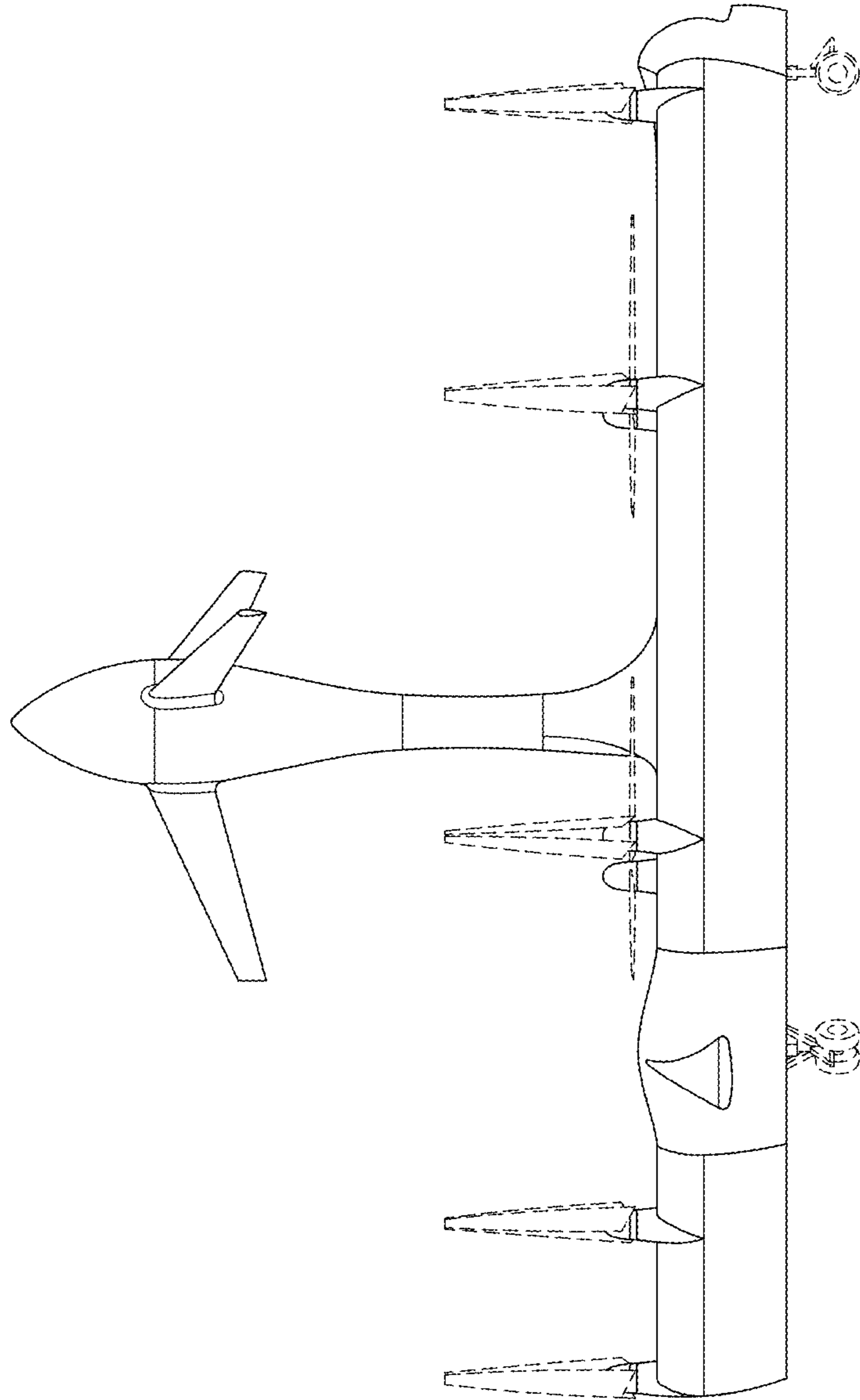

FIG. 25

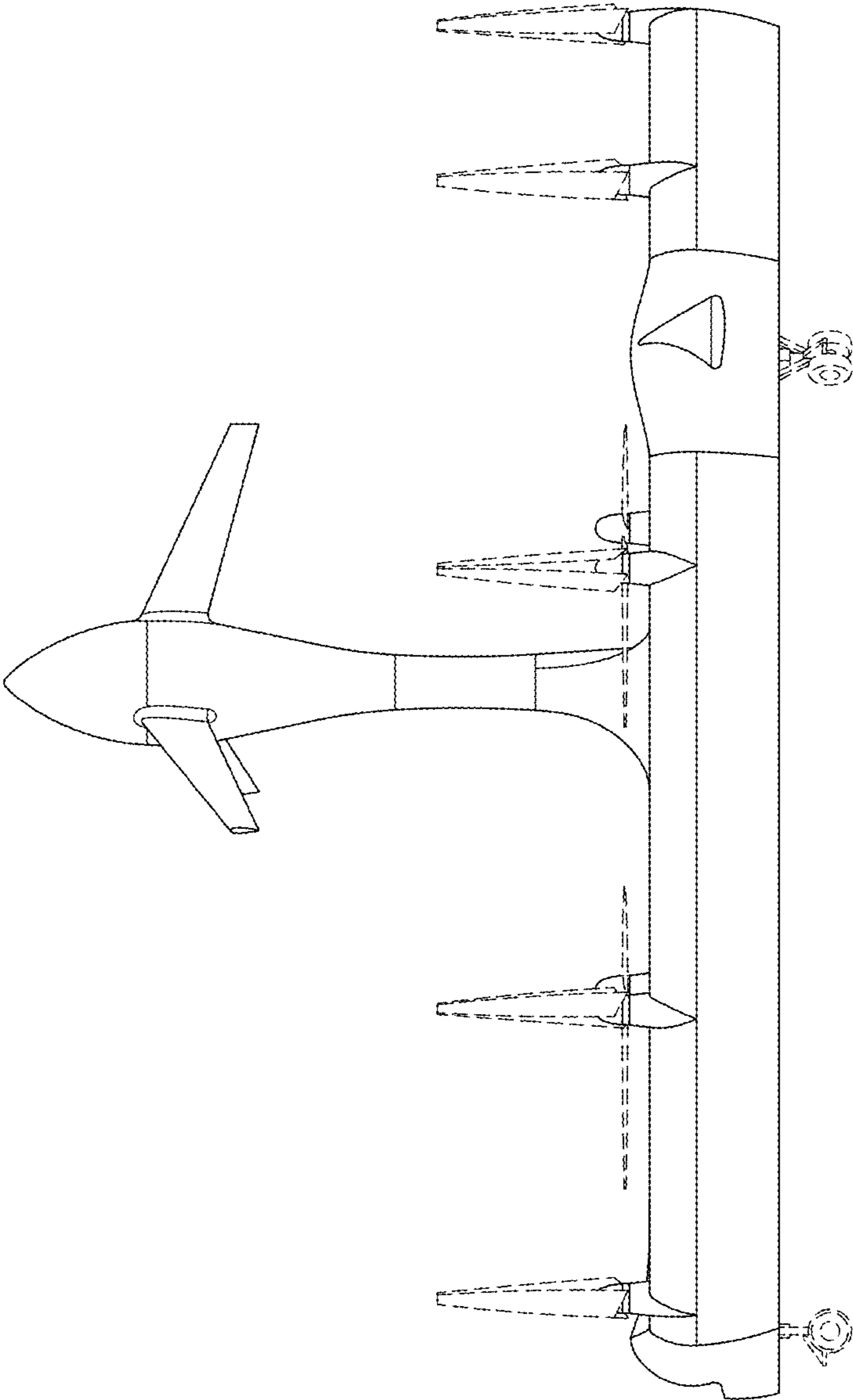

FIG. 26

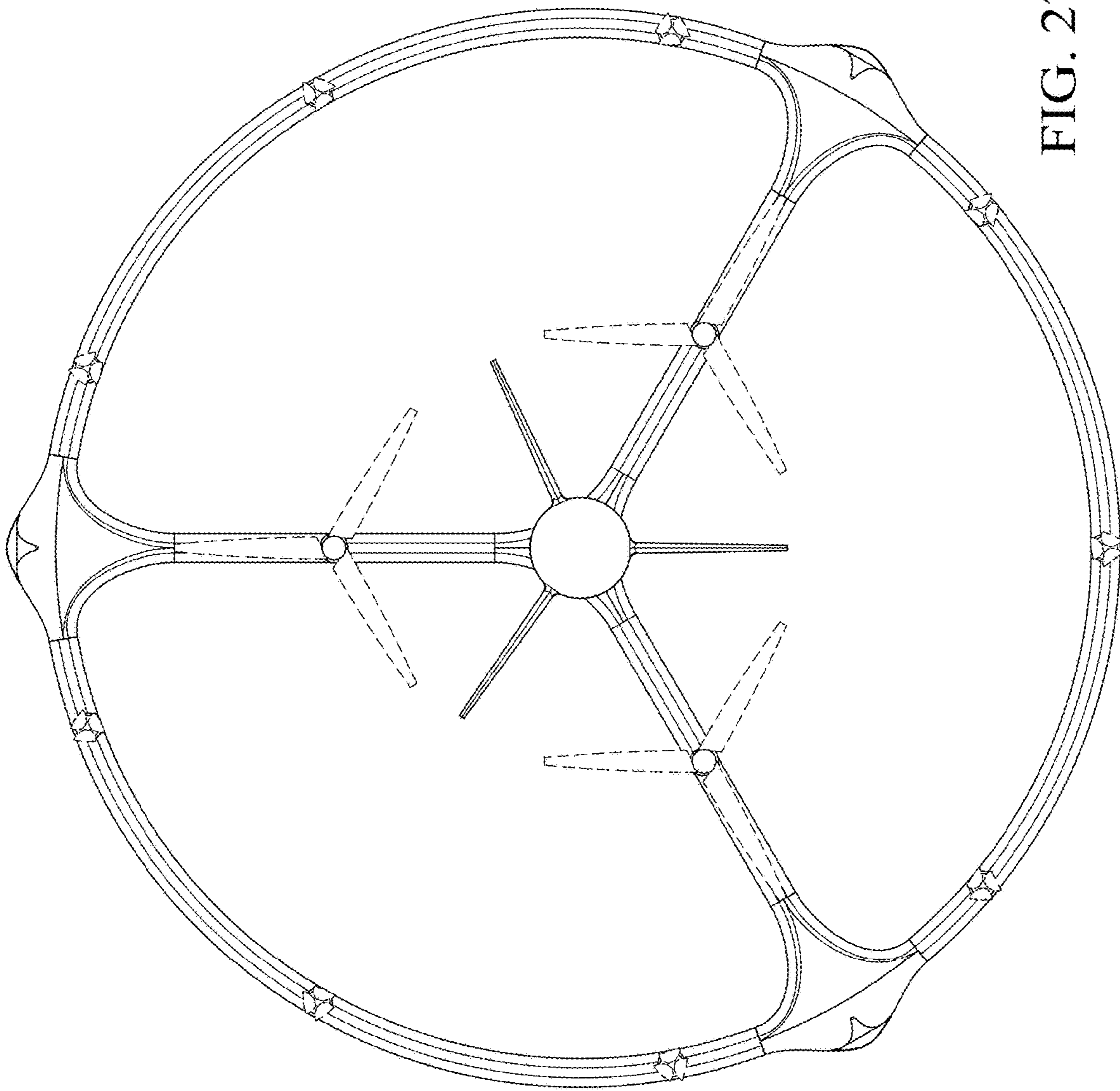

FIG. 27

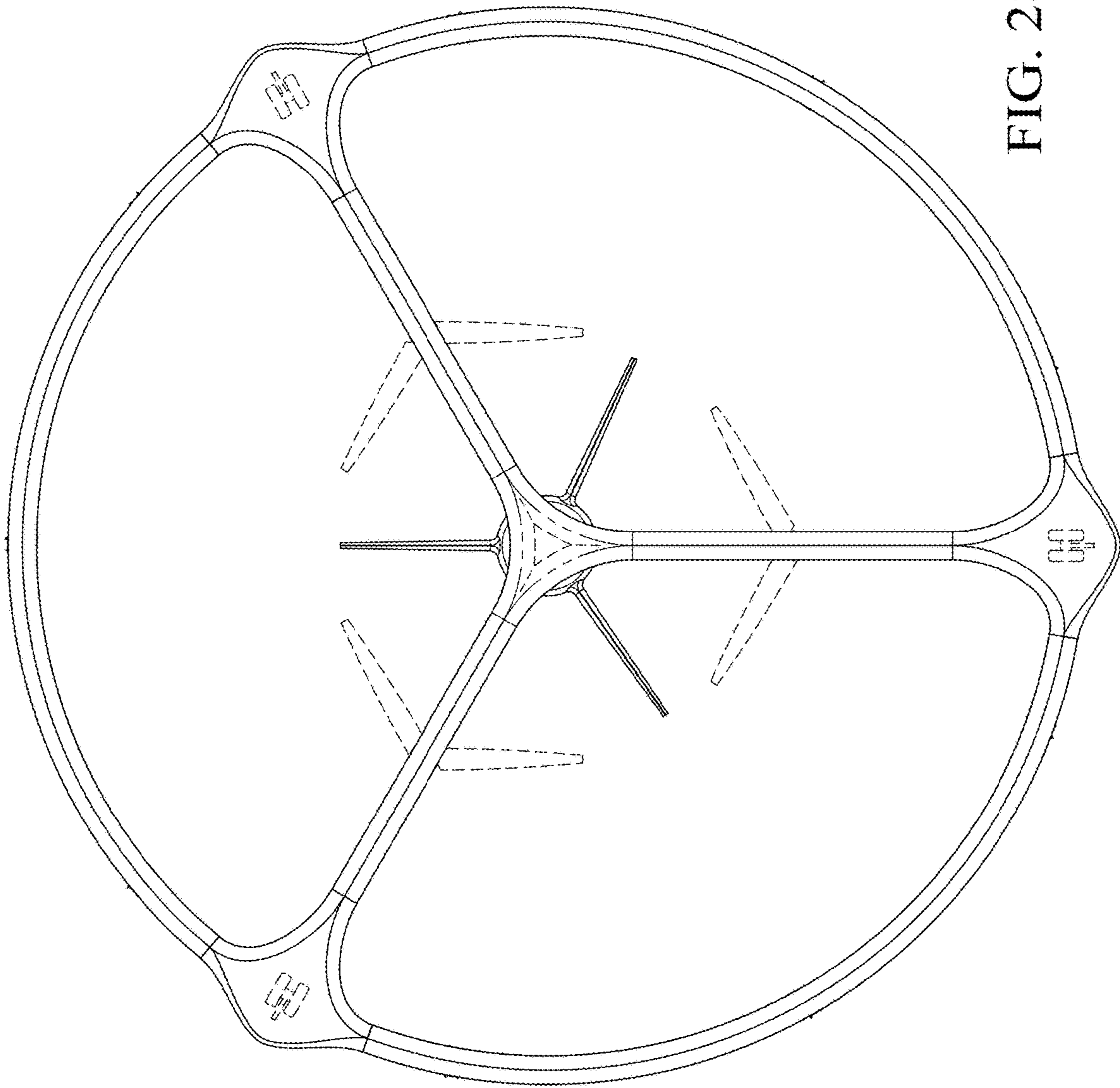

FIG. 28