



US00D798529S

(12) **United States Design Patent**  
**Rolston**

(10) **Patent No.:** **US D798,529 S**

(45) **Date of Patent:** **\*\* Oct. 3, 2017**

(54) **FRONT SUSPENDERS**

(71) Applicant: **George A. Rolston**, Toronto (CA)

(72) Inventor: **George A. Rolston**, Toronto (CA)

(\*\*) Term: **14 Years**

(21) Appl. No.: **29/474,552**

(22) Filed: **Oct. 24, 2014**

(51) **LOC (10) Cl.** ..... **02-07**

(52) **U.S. Cl.**  
USPC ..... **D2/626**

(58) **Field of Classification Search**  
USPC ..... D2/624-629, 634-640; D11/216-219,  
D11/231, 232, 238; D24/190  
CPC ..... A41F 11/02; A41F 11/06; A41F 11/08;  
A41F 11/16; A41F 17/00; A41F 3/02;  
A41F 9/00; A41F 9/002; A41F 9/007;  
A44B 11/20; A44B 17/00; B60R  
2022/006; B60R 22/00  
See application file for complete search history.

5,177,813 A \* 1/1993 Bosack ..... A41F 3/02  
2/323

6,959,455 B2 \* 11/2005 Hall ..... A41F 19/00  
2/340

D595,930 S \* 7/2009 Perry ..... D2/626

D692,638 S \* 11/2013 Herman ..... D2/626

2004/0168286 A1 \* 9/2004 Herman ..... A41F 3/02  
24/513

2011/0083254 A1 \* 4/2011 Trutna ..... A41F 1/002  
2/326

2015/0101109 A1 \* 4/2015 Herman ..... A41F 3/02  
2/326

**FOREIGN PATENT DOCUMENTS**

CA 155771 \* 2/2015

\* cited by examiner

*Primary Examiner* — Celia Murphy

*Assistant Examiner* — Clare Ann Gannon

(57) **CLAIM**

I claim the ornamental design for suspenders, as shown and described.

**DESCRIPTION**

FIG. 1 is a front perspective view of the suspenders, showing my new design in position of use on a human figure;  
FIG. 2 is a side elevation view thereof;  
FIG. 3 is a front elevation view thereof;  
FIG. 4 is a rear perspective view thereof;  
FIG. 5 is a top plan view thereof; and,  
FIG. 6 is a bottom perspective view thereof.  
The broken lines showing a human figure in FIG. 1 depict environment that forms no part of the claimed design.

**1 Claim, 3 Drawing Sheets**

(56) **References Cited**  
**U.S. PATENT DOCUMENTS**

D136,651 S \* 11/1943 Thorne ..... D2/626

2,564,564 A \* 8/1951 Cookman ..... A41F 9/002  
2/310

2,710,486 A \* 6/1955 Blatt ..... A41F 11/02  
2/306

3,164,845 A \* 1/1965 Fowler ..... A41F 5/00  
2/117

3,484,870 A \* 12/1969 Tempelhof ..... A41D 1/08  
2/227

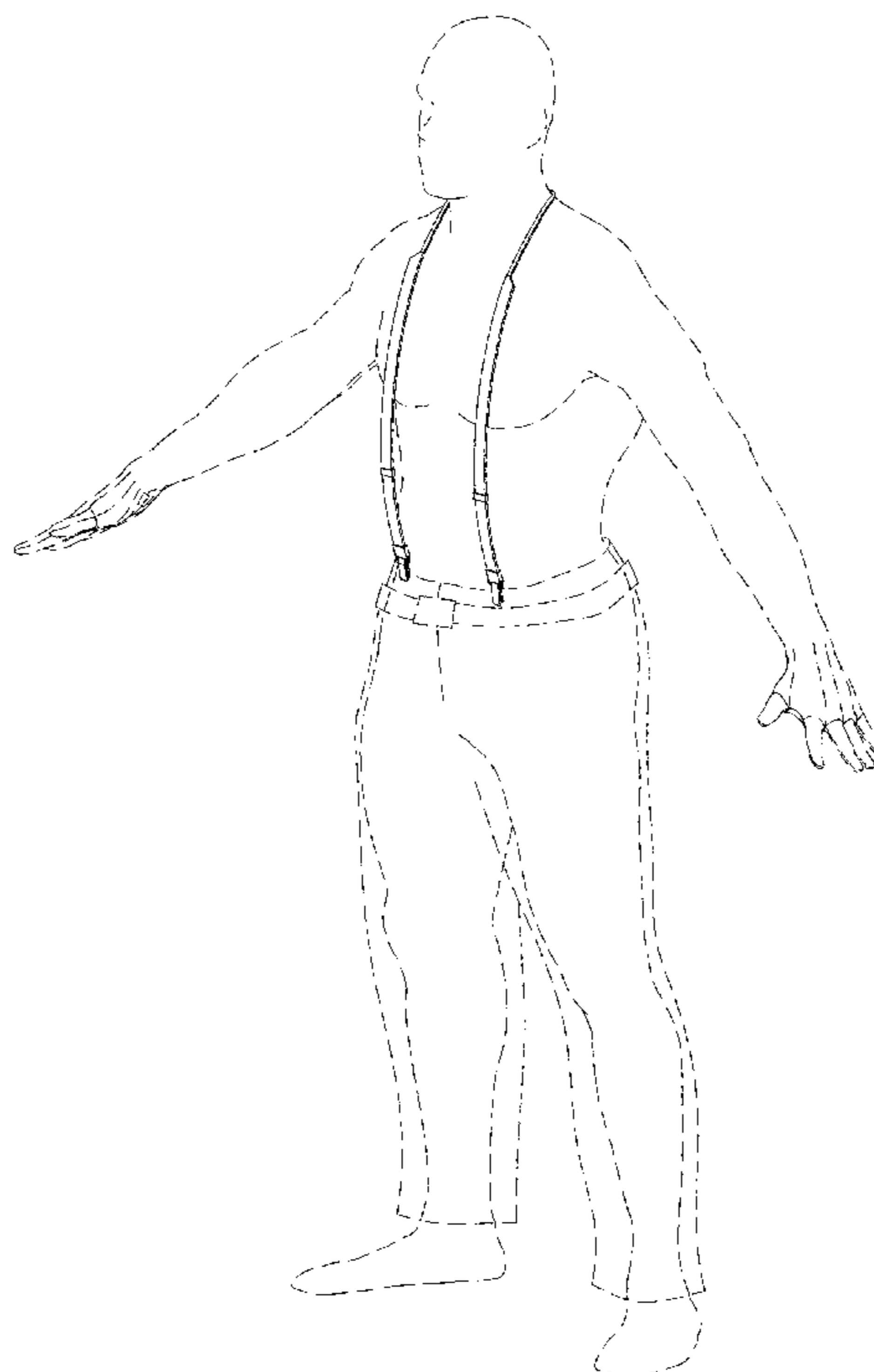

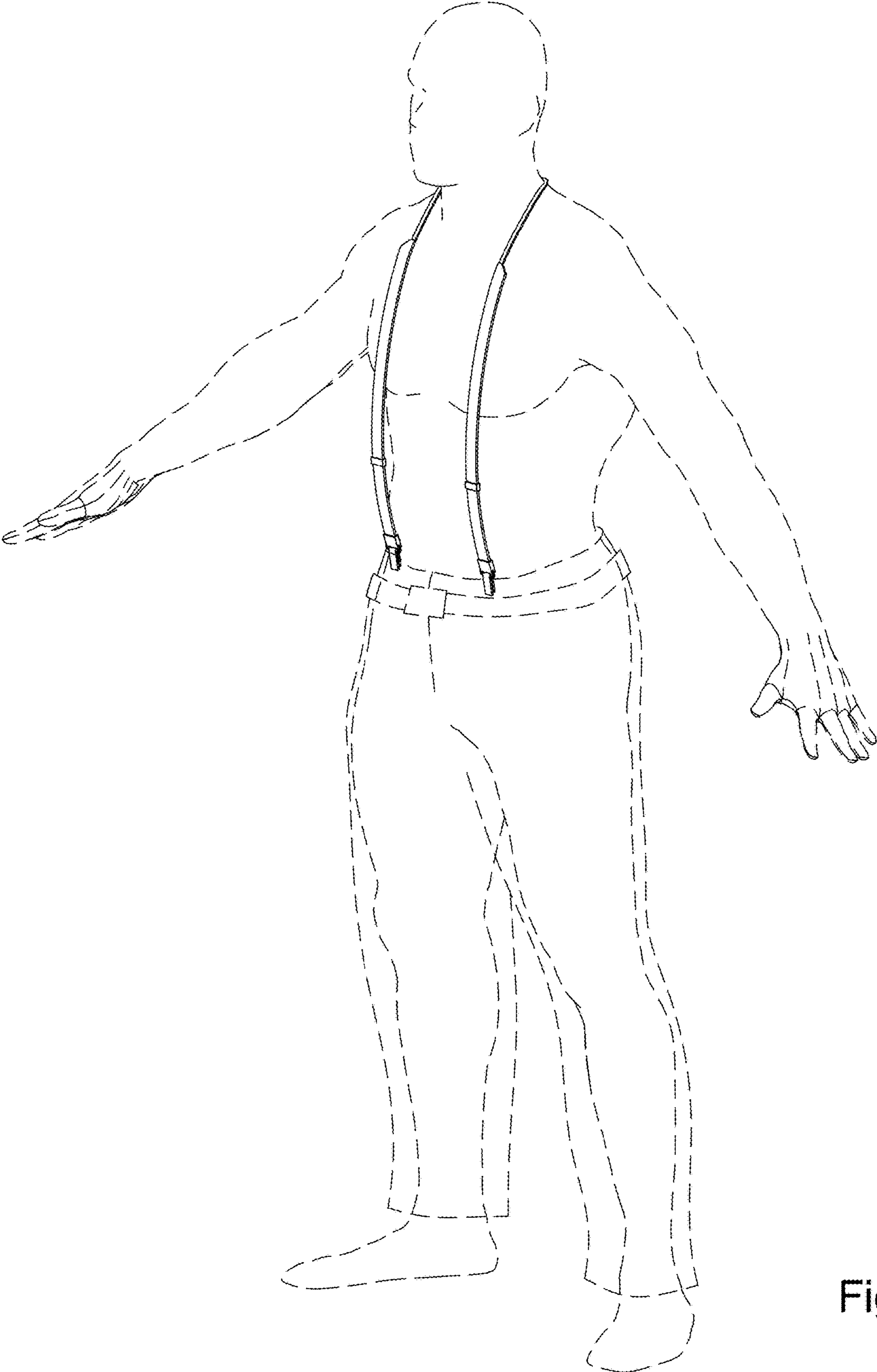

Fig. 1

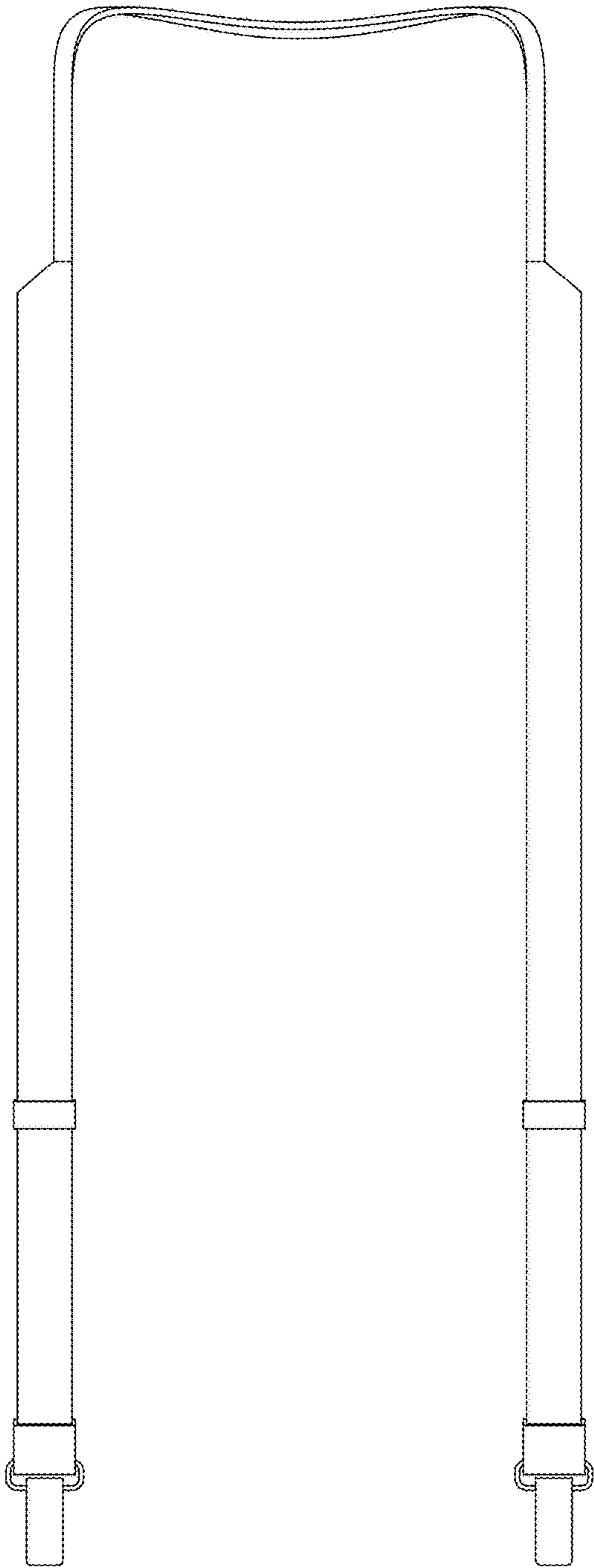

Fig. 3

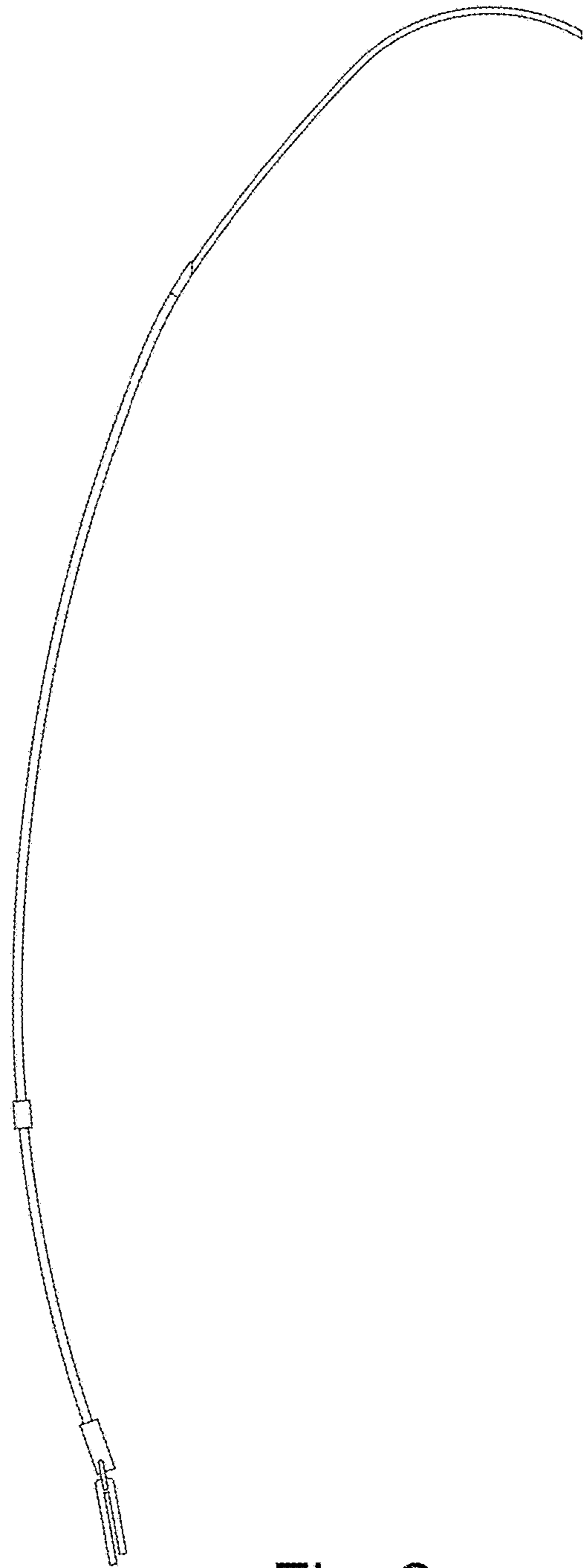

Fig. 2

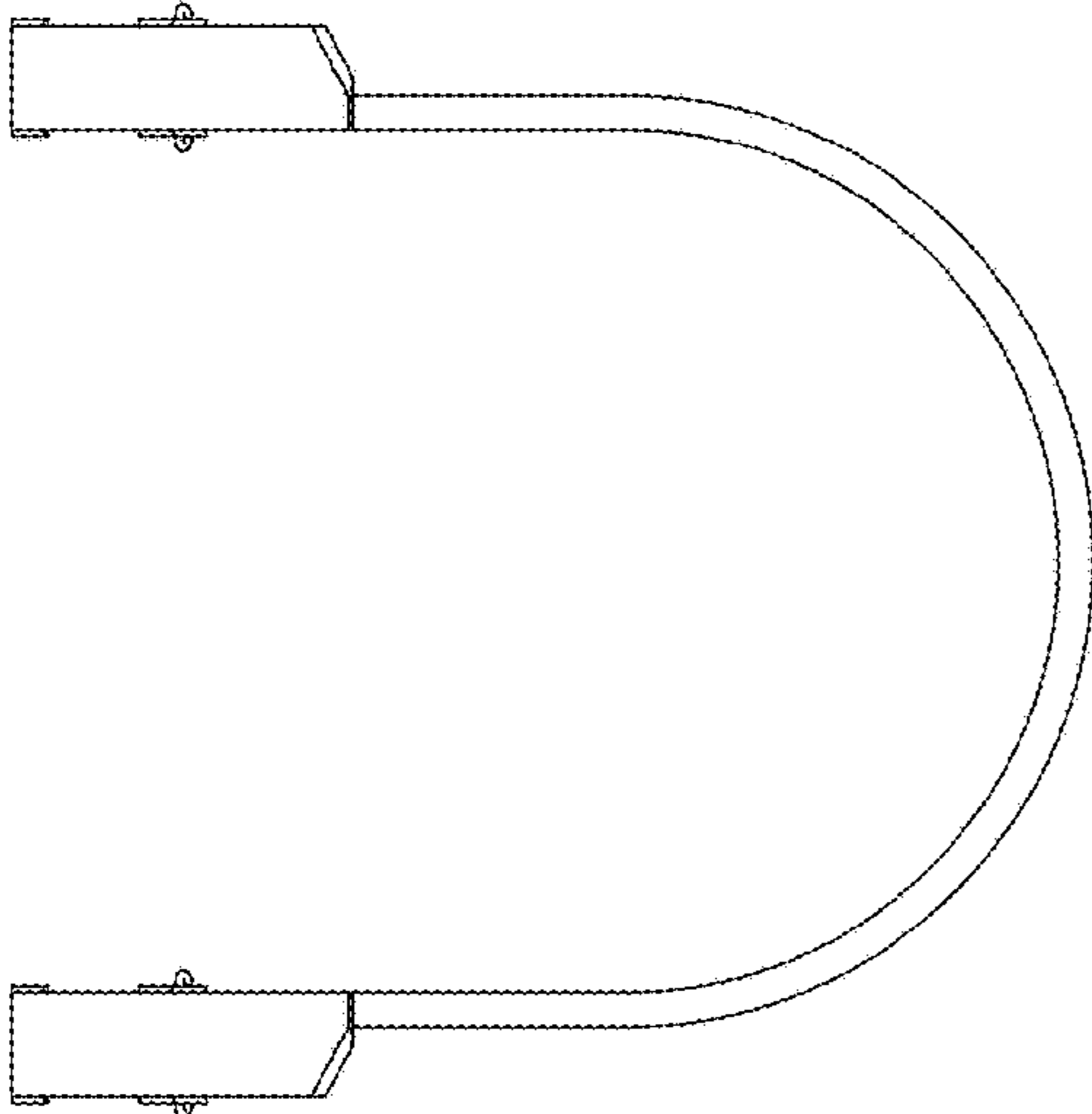

Fig. 5

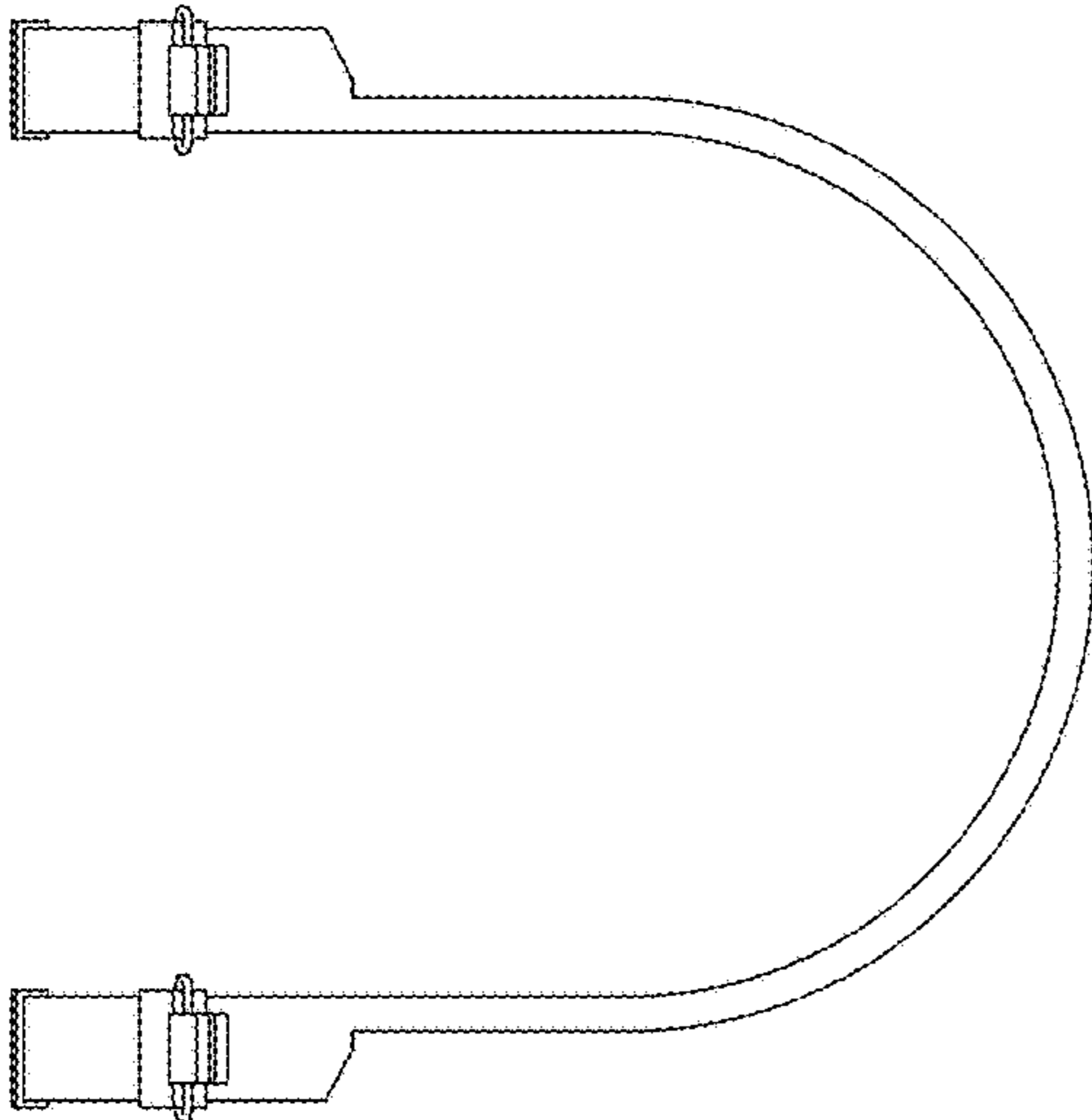

Fig. 6

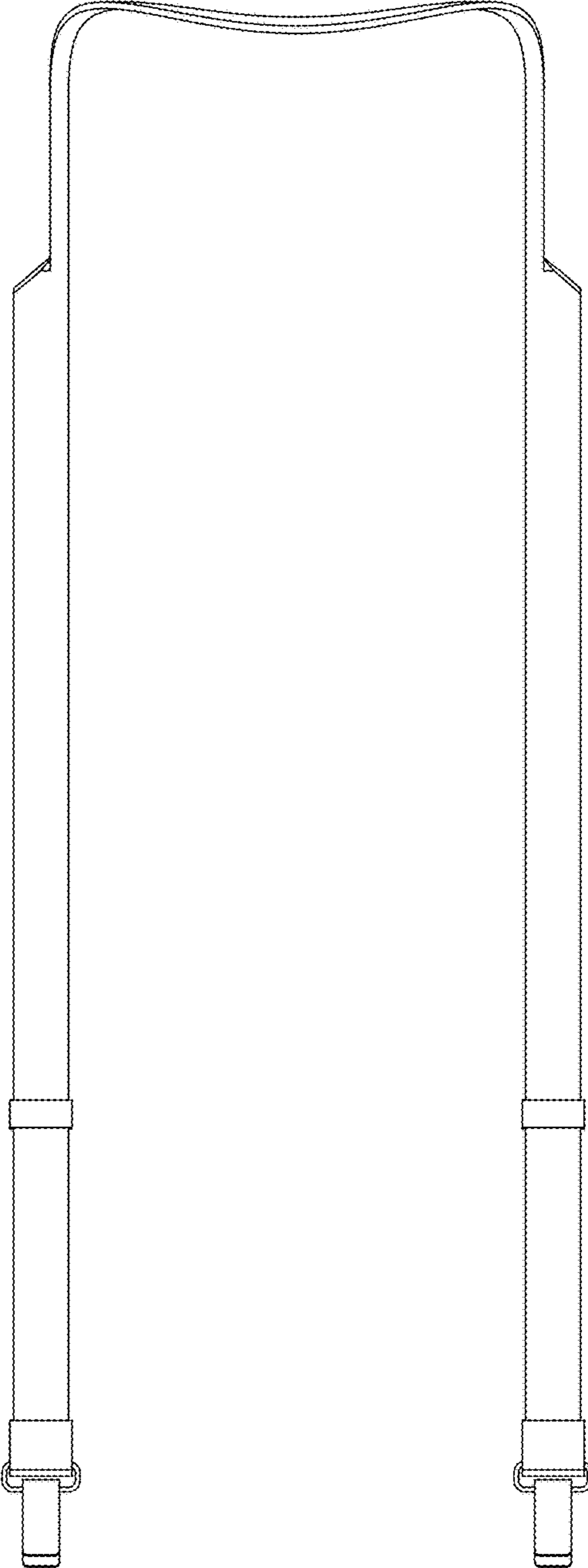

Fig. 4