



US00D798399S

(12) **United States Design Patent** (10) **Patent No.:** **US D798,399 S**  
**Hooper et al.** (45) **Date of Patent:** **\*\* Sep. 26, 2017**

- (54) **HOUSING OF AN EXERCISE DEVICE**
- (71) Applicant: **Precor Incorporated**, Woodinville, WA (US)
- (72) Inventors: **Elijah E. Hooper**, Seattle, WA (US);  
**Joshua S. Engstrom**, Woodinville, WA (US)
- (73) Assignee: **Precor Incorporated**, Woodinville, WA (US)
- (\*\*) Term: **15 Years**
- (21) Appl. No.: **29/581,975**
- (22) Filed: **Oct. 24, 2016**
- (51) **LOC (10) Cl.** ..... **21-02**
- (52) **U.S. Cl.**  
USPC ..... **D21/694**
- (58) **Field of Classification Search**  
USPC ..... 482/51-52, 54, 57, 66, 68, 70, 72;  
D12/42, 106, 115, 133, 181, 345;  
D19/99; D20/8, 22; D21/662, 663,  
D21/665-671, 673, 685, 694, 696-697  
CPC ..... A63B 2022/0658; A63B 21/015; A63B  
22/0605  
See application file for complete search history.

- D429,781 S 8/2000 Arnold et al.
- 6,123,650 A 9/2000 Birrell
- 6,146,313 A 11/2000 Whan-tong et al.
- 6,165,107 A 12/2000 Birrell
- 6,238,321 B1 5/2001 Arnold et al.
- D449,356 S 10/2001 Arnold et al.
- D450,100 S \* 11/2001 Hsu ..... D21/694  
(Continued)

**OTHER PUBLICATIONS**

Precor "Elliptical Fitness Cross Trainer", <https://www.precor.com/en-us/commercial/cardio/ellipticals/efx-865-elliptical-fitness-crosstrainer>. Jul. 27, 2017. shown in p. 1, Item # EFX 865.\*

*Primary Examiner* — Cynthia Ramirez  
*Assistant Examiner* — Michael Maharajh  
(74) *Attorney, Agent, or Firm* — Terence P. O'Brien

(57) **CLAIM**

We claim the ornamental design for a housing of an exercise device, as shown and described.

**DESCRIPTION**

FIG. 1 a side, top perspective view of a housing of an exercise device;  
FIG. 2 is a close-up perspective view of the housing of the exercise device of FIG. 1;  
FIG. 3 is a rear perspective view of the housing of the exercise device of FIG. 1;  
FIG. 4 is a first side view of the housing of the exercise device of FIG. 1;  
FIG. 5 is close up side view of the housing of the exercise device of FIG. 4; and,  
FIG. 6 is a rear view of the housing of the exercise device of FIG. 1.

The ornamental design that is claimed is shown in solid lines in the drawings. The evenly spaced broken lines shown in the figures are for the purpose of showing environment and form no part of the claimed design.

**1 Claim, 4 Drawing Sheets**

- (56) **References Cited**  
U.S. PATENT DOCUMENTS
- D302,451 S 7/1989 Bull et al.
- D303,695 S 9/1989 Smith et al.
- D304,358 S 10/1989 Armstrong et al.
- D314,597 S 2/1991 Armstrong et al.
- D321,229 S 10/1991 Dalton et al.
- D328,625 S 8/1992 Arthur et al.
- D328,770 S 8/1992 Henderson et al.
- D372,282 S 7/1996 Pasero et al.
- 5,685,804 A 11/1997 Whan-Tong et al.
- D388,847 S 1/1998 Whan-tong et al.
- D408,477 S 4/1999 Arnold et al.
- D410,978 S 6/1999 Littrell et al.

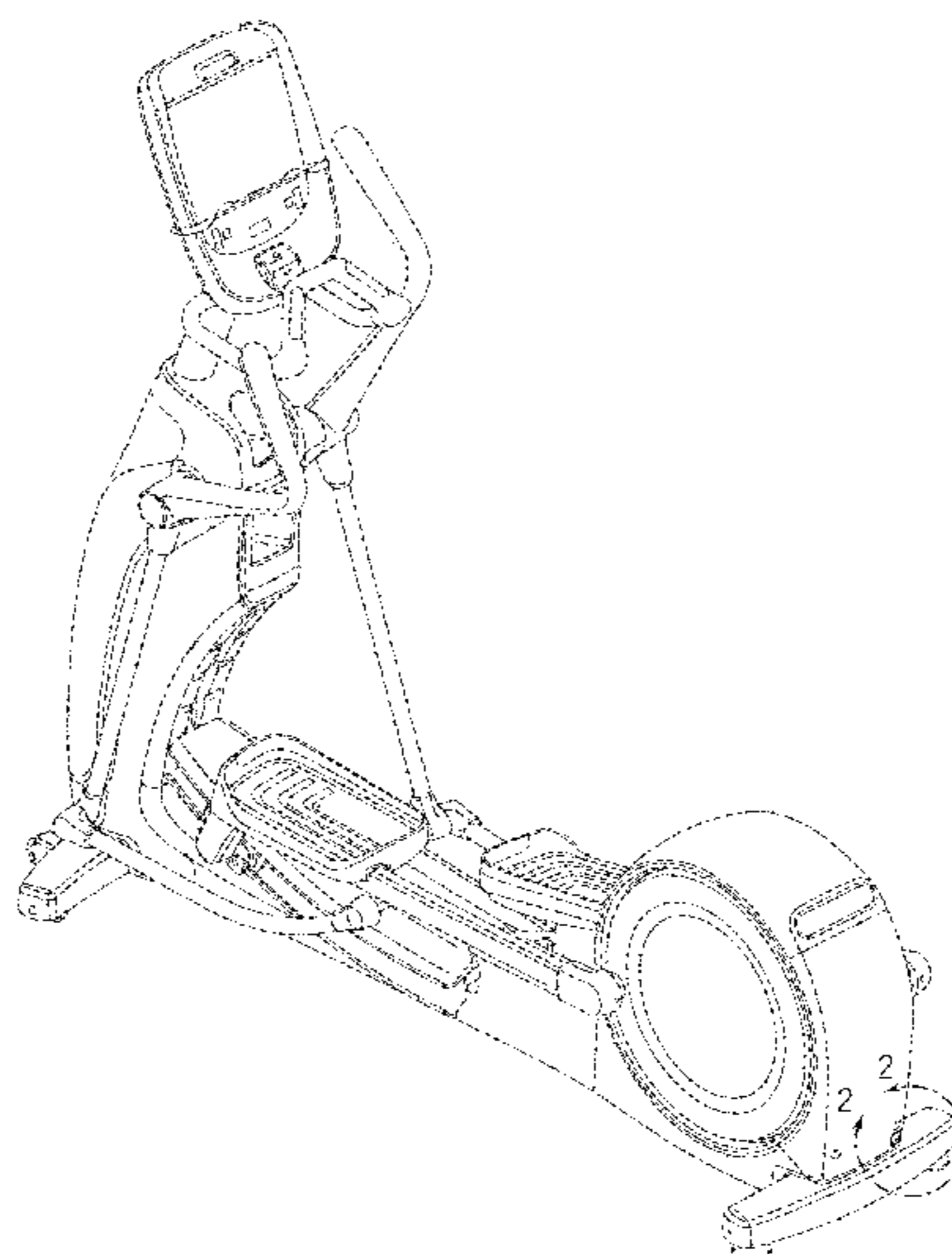

(56)

References Cited

U.S. PATENT DOCUMENTS

|           |      |         |                  |                       |
|-----------|------|---------|------------------|-----------------------|
| D464,688  | S    | 10/2002 | May et al.       |                       |
| D464,689  | S    | 10/2002 | May et al.       |                       |
| D465,000  | S    | 10/2002 | Arnold et al.    |                       |
| 6,482,130 | B1   | 11/2002 | Pasero et al.    |                       |
| D475,424  | S *  | 6/2003  | Lee .....        | D21/694               |
| D484,931  | S *  | 1/2004  | Tsai .....       | D21/694               |
| 6,749,540 | B1   | 6/2004  | Pasero et al.    |                       |
| 6,752,744 | B2   | 6/2004  | Arnold et al.    |                       |
| 6,939,271 | B1   | 9/2005  | Whan-tong et al. |                       |
| D530,758  | S *  | 10/2006 | Kim .....        | D21/668               |
| D559,925  | S    | 1/2008  | Horita           |                       |
| D567,310  | S *  | 4/2008  | Chen .....       | D21/668               |
| D567,313  | S    | 4/2008  | Horita           |                       |
| D567,314  | S    | 4/2008  | Horita           |                       |
| D567,315  | S    | 4/2008  | Horita           |                       |
| D575,363  | S    | 8/2008  | Horita           |                       |
| D575,837  | S    | 8/2008  | Horita           |                       |
| D590,033  | S *  | 4/2009  | Wang .....       | D21/668               |
| 7,513,855 | B1 * | 4/2009  | Yeh .....        | A63B 22/001<br>482/51 |
| D594,072  | S    | 6/2009  | Horita           |                       |
| D600,293  | S    | 9/2009  | Horita           |                       |
| 7,691,034 | B2   | 4/2010  | May et al.       |                       |
| 7,704,192 | B2   | 4/2010  | Dyer et al.      |                       |
| 7,731,634 | B2   | 6/2010  | Stewart et al.   |                       |
| 7,758,472 | B2   | 7/2010  | Stewart          |                       |
| 7,922,625 | B2   | 4/2011  | Grind            |                       |
| 8,419,598 | B2   | 4/2013  | Dyer et al.      |                       |
| D687,911  | S    | 8/2013  | Horita           |                       |
| D690,375  | S    | 9/2013  | Horita           |                       |
| D690,784  | S    | 10/2013 | Horita           |                       |
| 8,556,779 | B2   | 10/2013 | Grind            |                       |
| D703,278  | S    | 4/2014  | Horita           |                       |
| 9,468,795 | B2   | 10/2016 | Arnold et al.    |                       |

\* cited by examiner

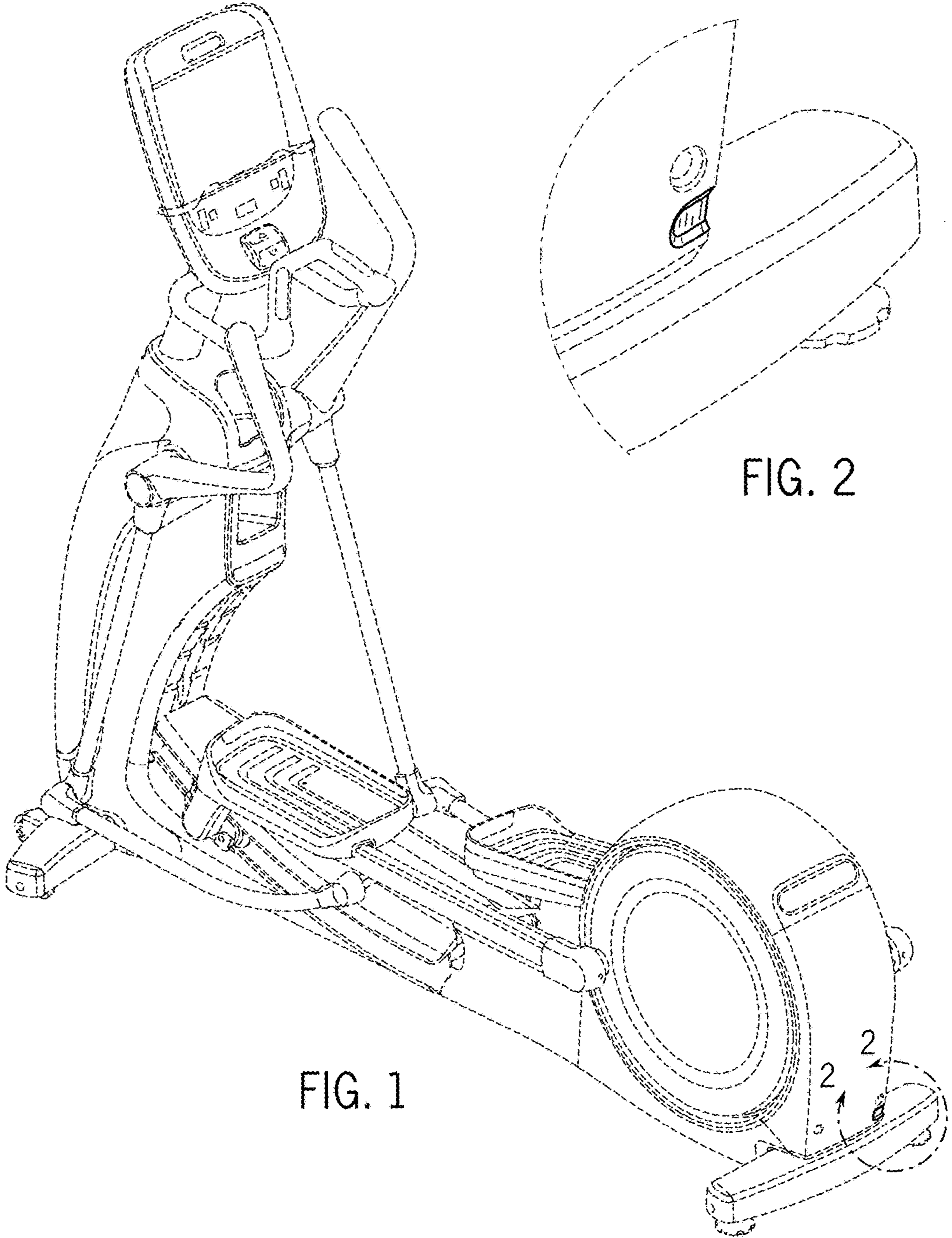

FIG. 1

FIG. 2

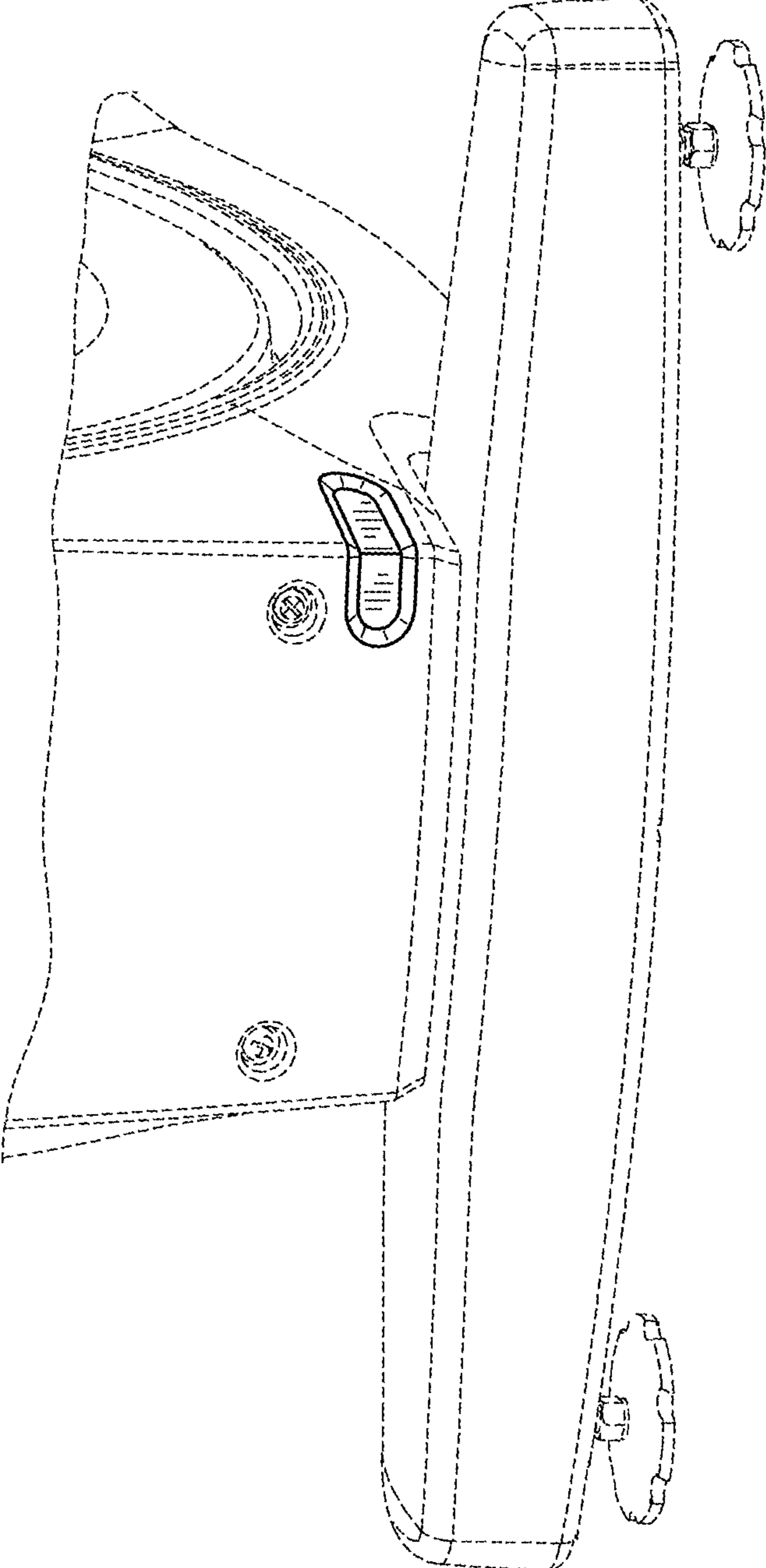
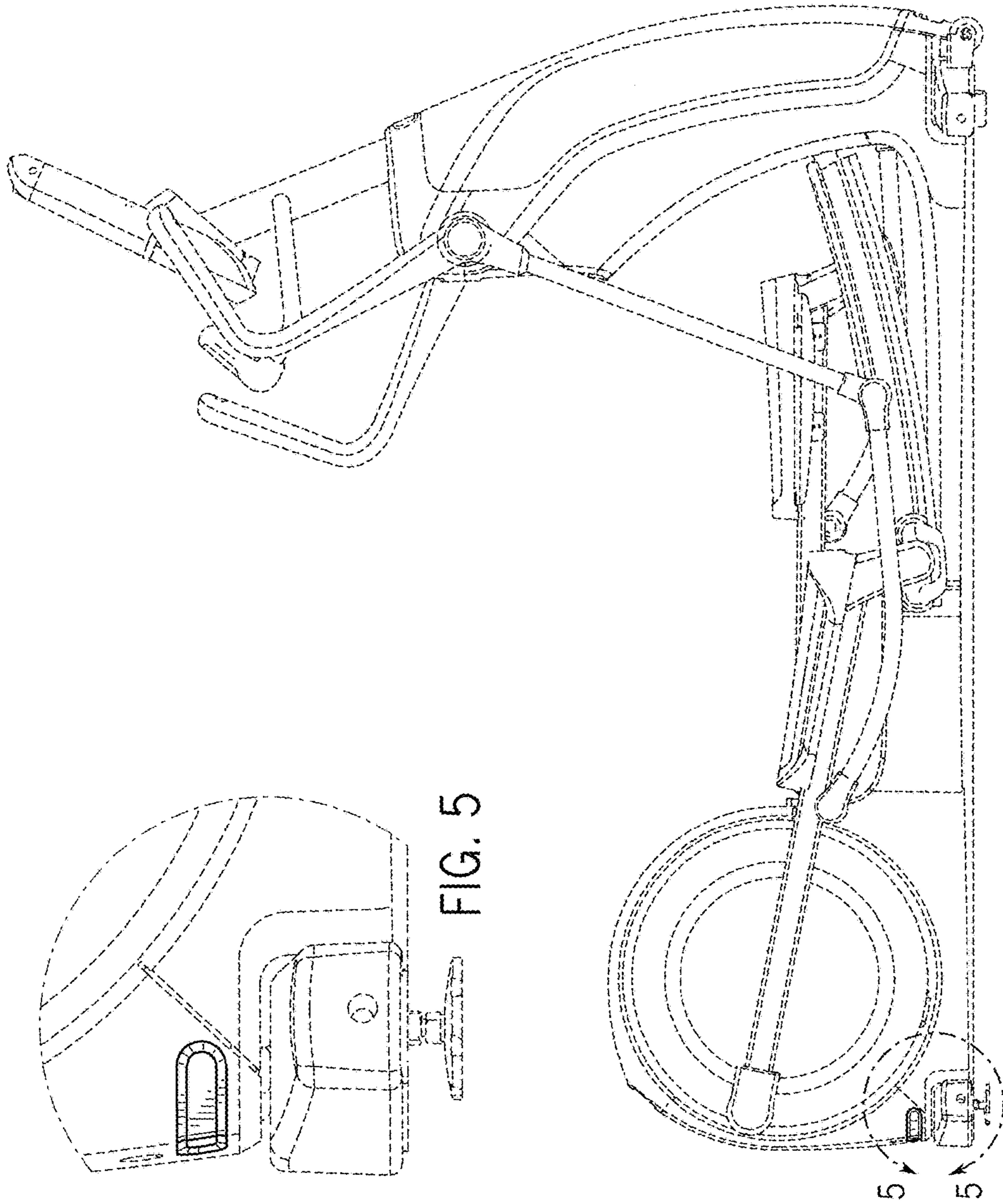

FIG. 3



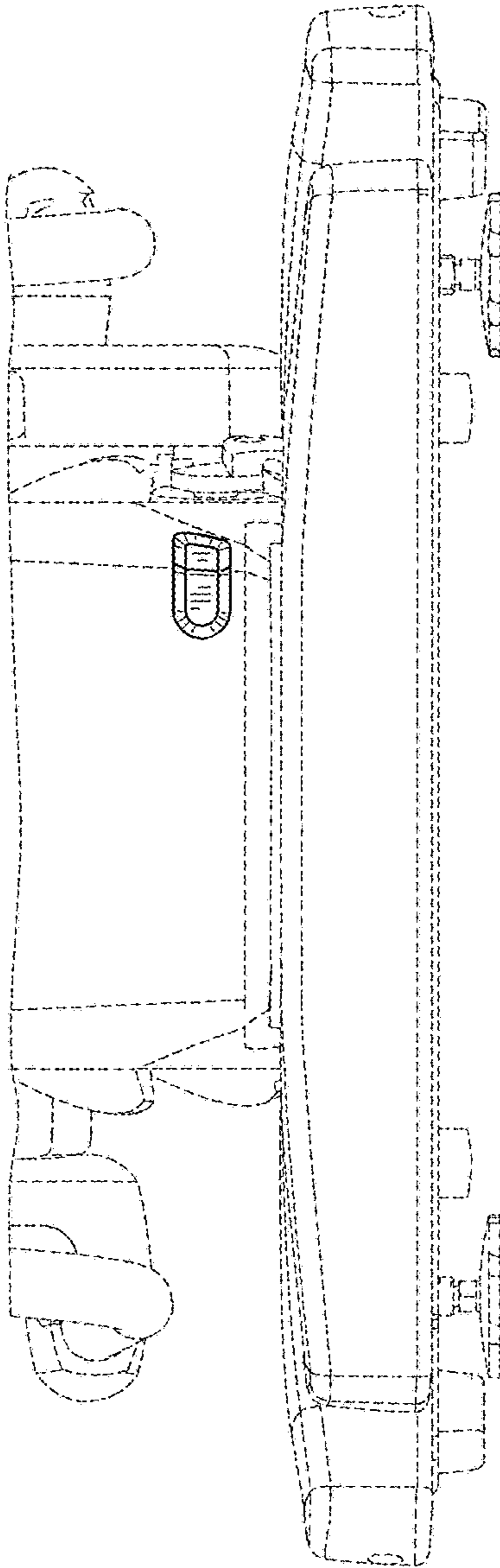

FIG. 6