



US00D798226S

(12) **United States Design Patent** (10) **Patent No.:** **US D798,226 S**
Parr et al. (45) **Date of Patent:** **** Sep. 26, 2017**

(54) **TIRE TREAD**
(71) Applicant: **Bridgestone Americas Tire Operations, LLC**, Nashville, OH (US)
(72) Inventors: **Richard S. Parr**, Canton, OH (US); **Aleksandr I. Shmagranoff**, Akron, OH (US)
(73) Assignee: **Bridgestone Americas Tire Operatons, LLC**, Nashville, TN (US)
(**) Term: **15 Years**
(21) Appl. No.: **29/579,121**
(22) Filed: **Sep. 28, 2016**
(51) **LOC (10) Cl.** **12-15**
(52) **U.S. Cl.**
USPC **D12/578**
(58) **Field of Classification Search**
USPC D12/568, 574-575, 577-580, 599
CPC B60C 1/0016; B60C 3/06; B60C 9/17;
B60C 11/0306; B60C 11/0302;
B60C 11/11; B60C 2011/0346;
B60C 2011/0365; B60C 2011/0369;
B60C 2011/0381
See application file for complete search history.

D639,235 S 6/2011 Reim et al.
D647,040 S 10/2011 Mathonet et al.
D648,673 S 11/2011 Koog
D662,456 S 6/2012 Corsi et al.
D700,883 S * 3/2014 Sareen D12/582
D710,294 S 8/2014 Dixon et al.
D715,217 S 10/2014 Dixon et al.
D719,907 S 12/2014 Ohara
(Continued)

OTHER PUBLICATIONS

Bridgestone Blizzak, posted at Bridgestonetire.com, posted on Jan. 25, 2013, site visited May 23, 2017, <http://www.bridgestonetire.com/tire/blizzak-w965#tire-reviews_strip-all>.*
(Continued)

Primary Examiner — Mary Ann Calabrese
Assistant Examiner — Messina L Smith
(74) *Attorney, Agent, or Firm* — Shaun J. Fox

(57) **CLAIM**
The ornamental design for a tire tread, as shown and described.

DESCRIPTION

FIG. 1 is a side perspective view of a tire tread showing our new design, it being understood that the tread pattern is repeated throughout the circumference of the tire tread, the opposite side being the same as that shown; FIG. 2 is a front elevational view thereof, the opposite side being identical thereto; FIG. 3 is an enlarged fragmentary front elevational view thereof; and, FIG. 4 is a side elevational of side view. The broken lines defining the shoulder ribs, tread lug walls, tread grooves, sidewall, inner bead, and the peripheral boundary between the claimed tire tread and the sidewall depict environmental subject matter that forms no part of the claimed design.

1 Claim, 4 Drawing Sheets

(56) **References Cited**
U.S. PATENT DOCUMENTS
D250,946 S * 1/1979 Germain D12/594
D383,102 S * 9/1997 Harris D12/600
D420,630 S * 2/2000 De Coninck D12/600
D481,990 S * 11/2003 Hanna D12/579
D492,643 S * 7/2004 Robert D12/579
D549,163 S * 8/2007 Maus D12/579
D573,942 S * 7/2008 Song D12/579
D615,482 S 5/2010 Nakano
D615,922 S 5/2010 Takano
D617,728 S 6/2010 de Benedittis et al.
D619,082 S 7/2010 de Benedittis et al.
D626,501 S 11/2010 Cazin-Bourguignon et al.

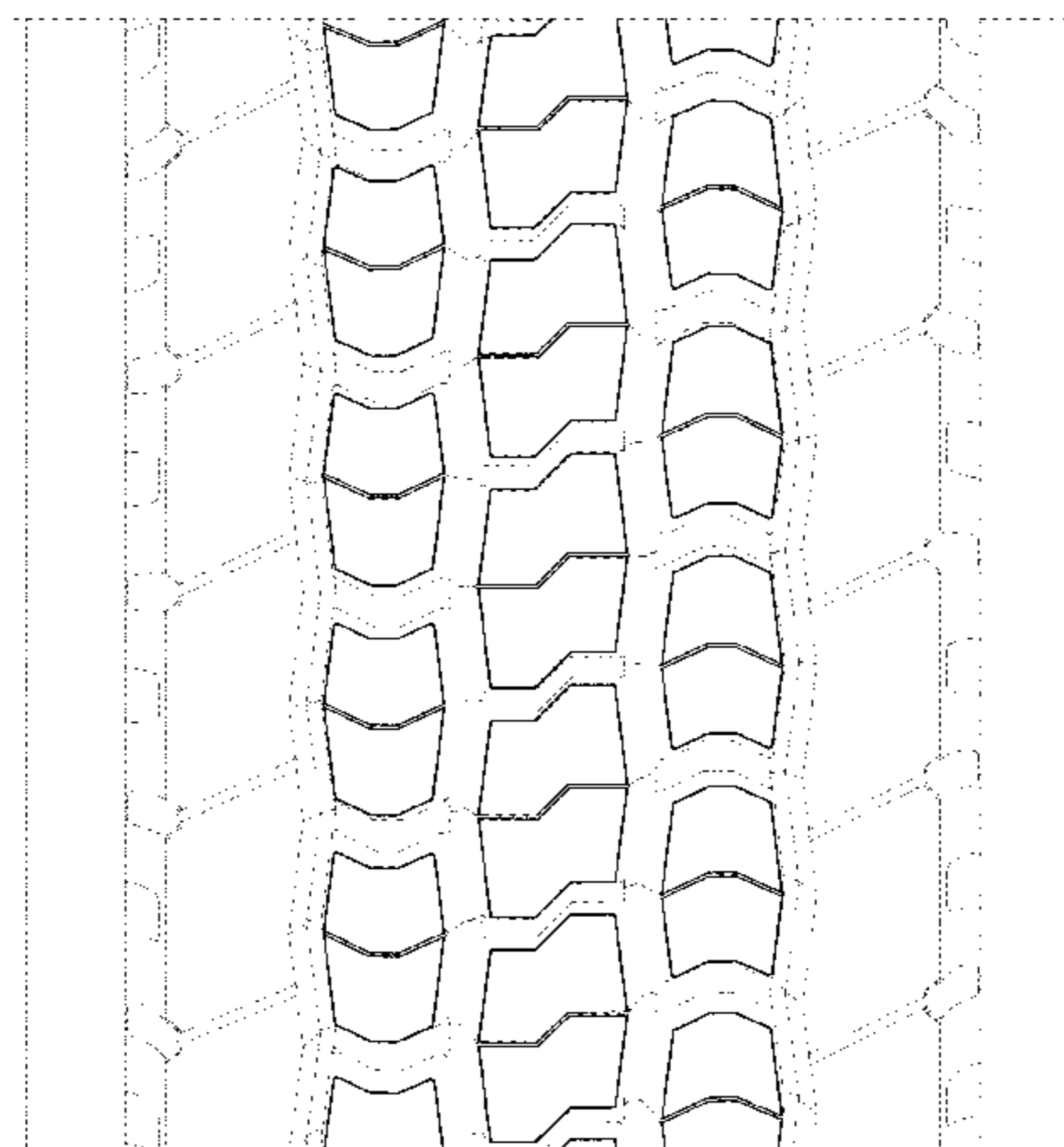
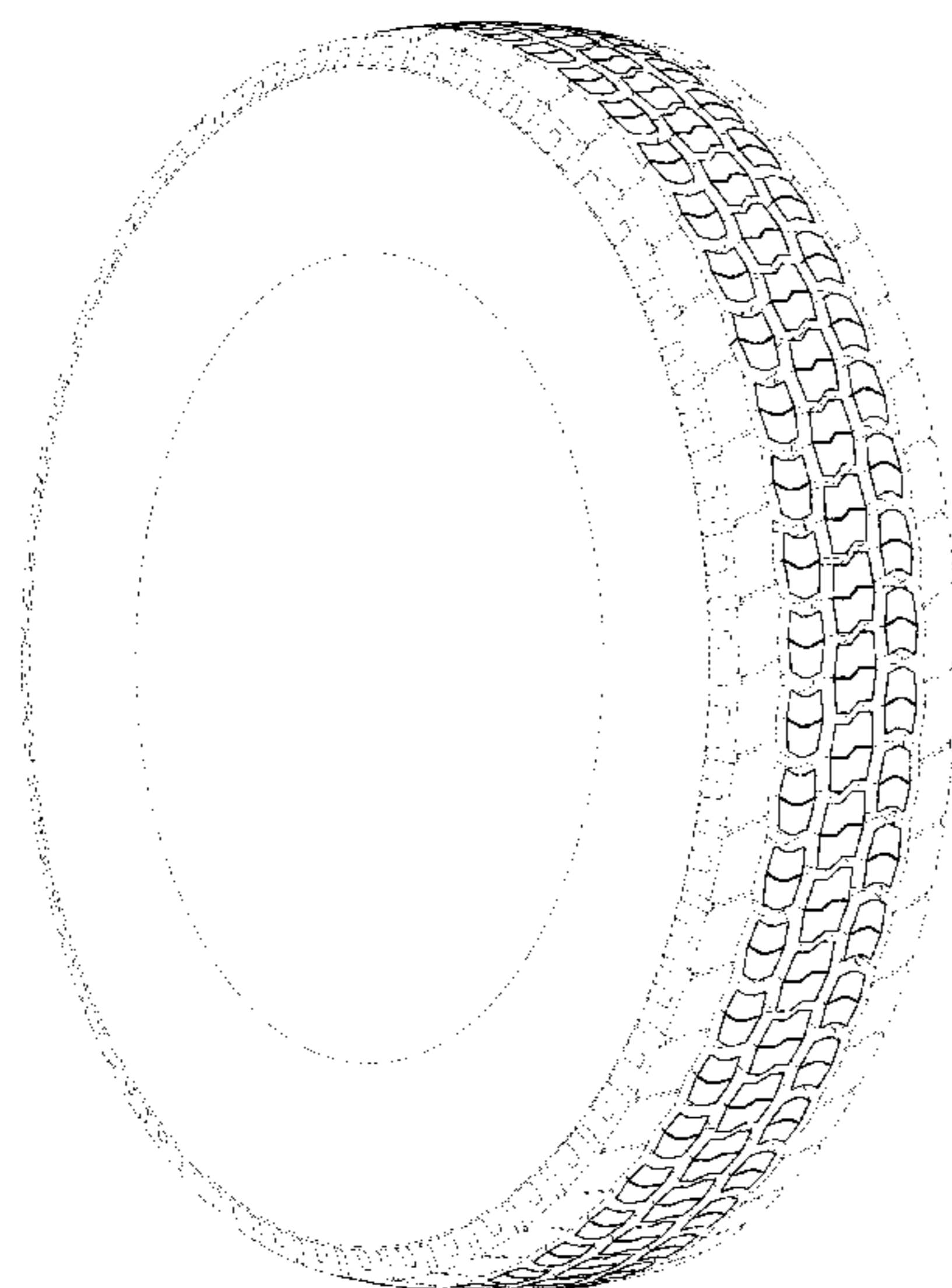

(56)

References Cited

U.S. PATENT DOCUMENTS

D722,553 S	2/2015	Corsi et al.	
D726,644 S *	4/2015	Kuwahara	D12/602
D730,273 S	5/2015	Schimmoeller	
D738,294 S	9/2015	Koog	
D738,813 S	9/2015	Wang	
D738,814 S	9/2015	Otani	
D740,210 S	10/2015	Uphouse et al.	
D741,790 S *	10/2015	Parr	D12/594
D746,224 S	12/2015	Drake	
D753,582 S	4/2016	Matsuda	
D767,475 S *	9/2016	Scheifele	D12/580
D784,251 S *	4/2017	Cerny	D12/600
2015/0075693 A1 *	3/2015	Dorfi	B29D 30/0061 152/523

OTHER PUBLICATIONS

Bridgestone: M726 EL, posted at Jordanscarcare.com, no posting date given, site visited May 23, 2017, <<http://jordanscarcare.com/m726-el-tires-mesquite-rowlett-tx#u=/Line:1400/DisplayAll:0>>.*

* cited by examiner

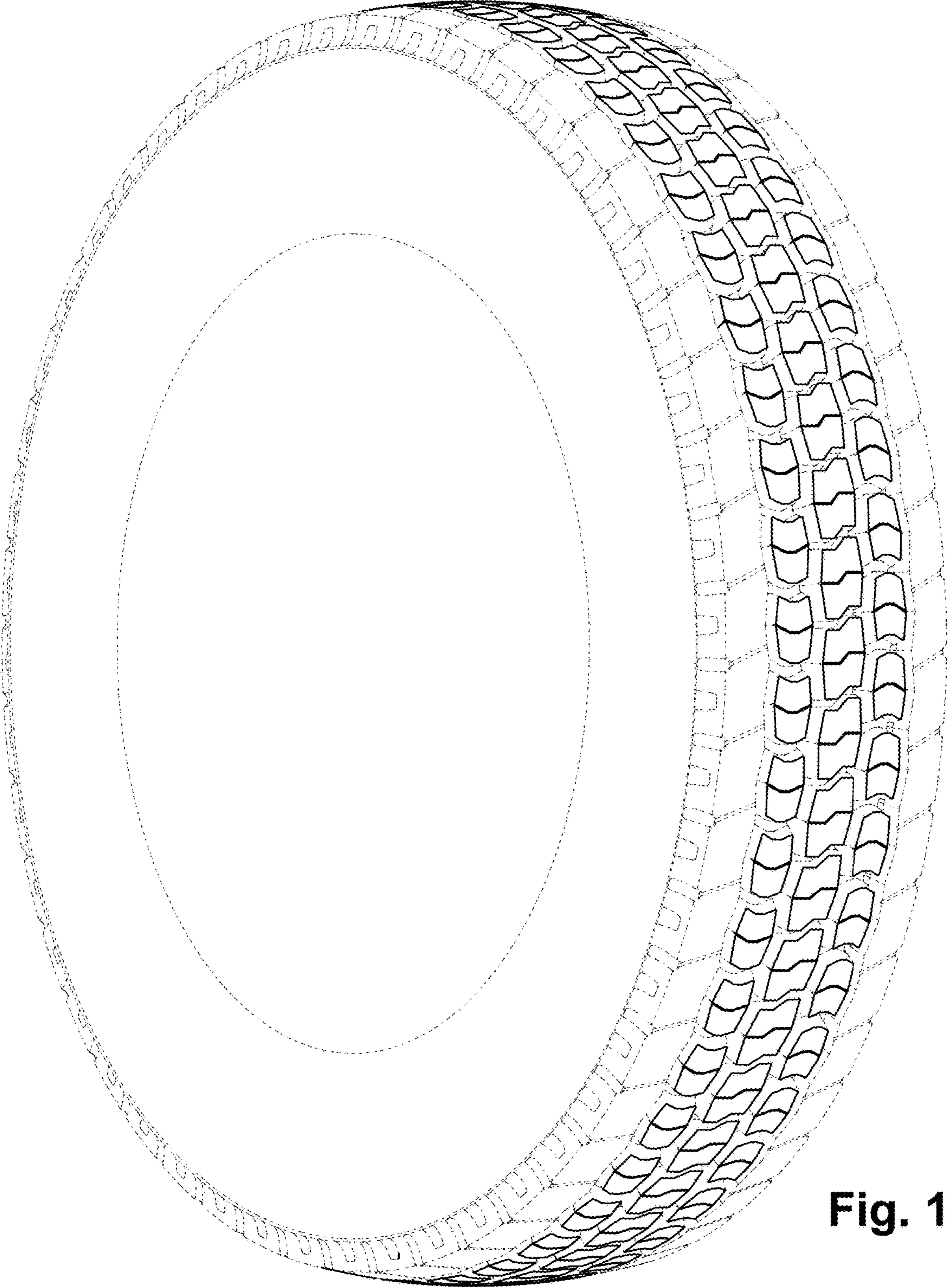

Fig. 1

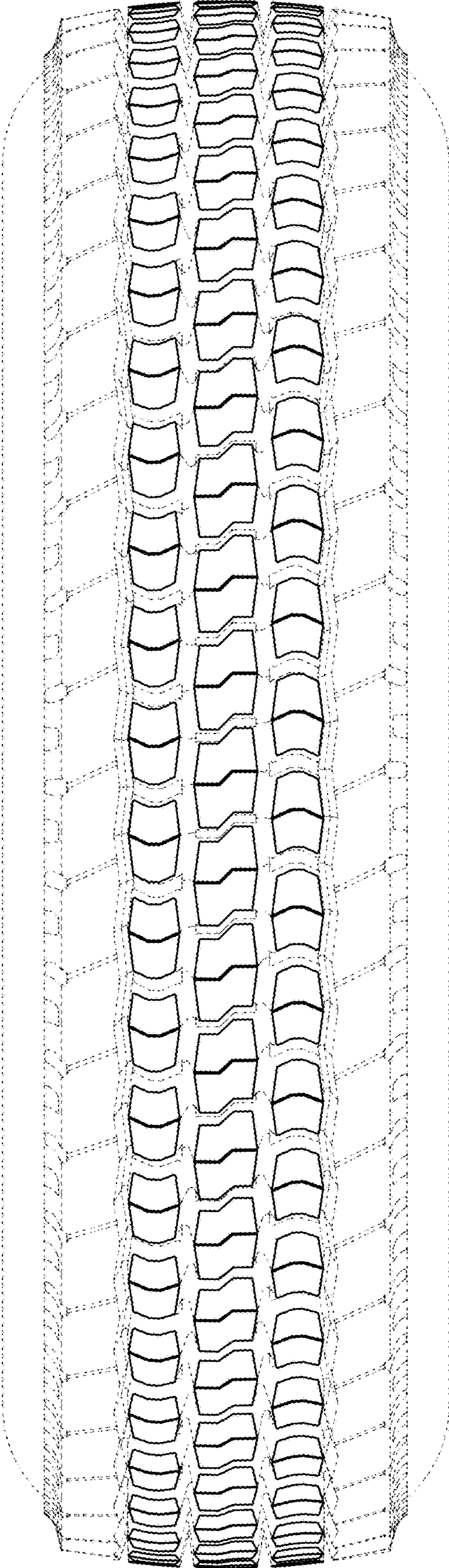

Fig. 2

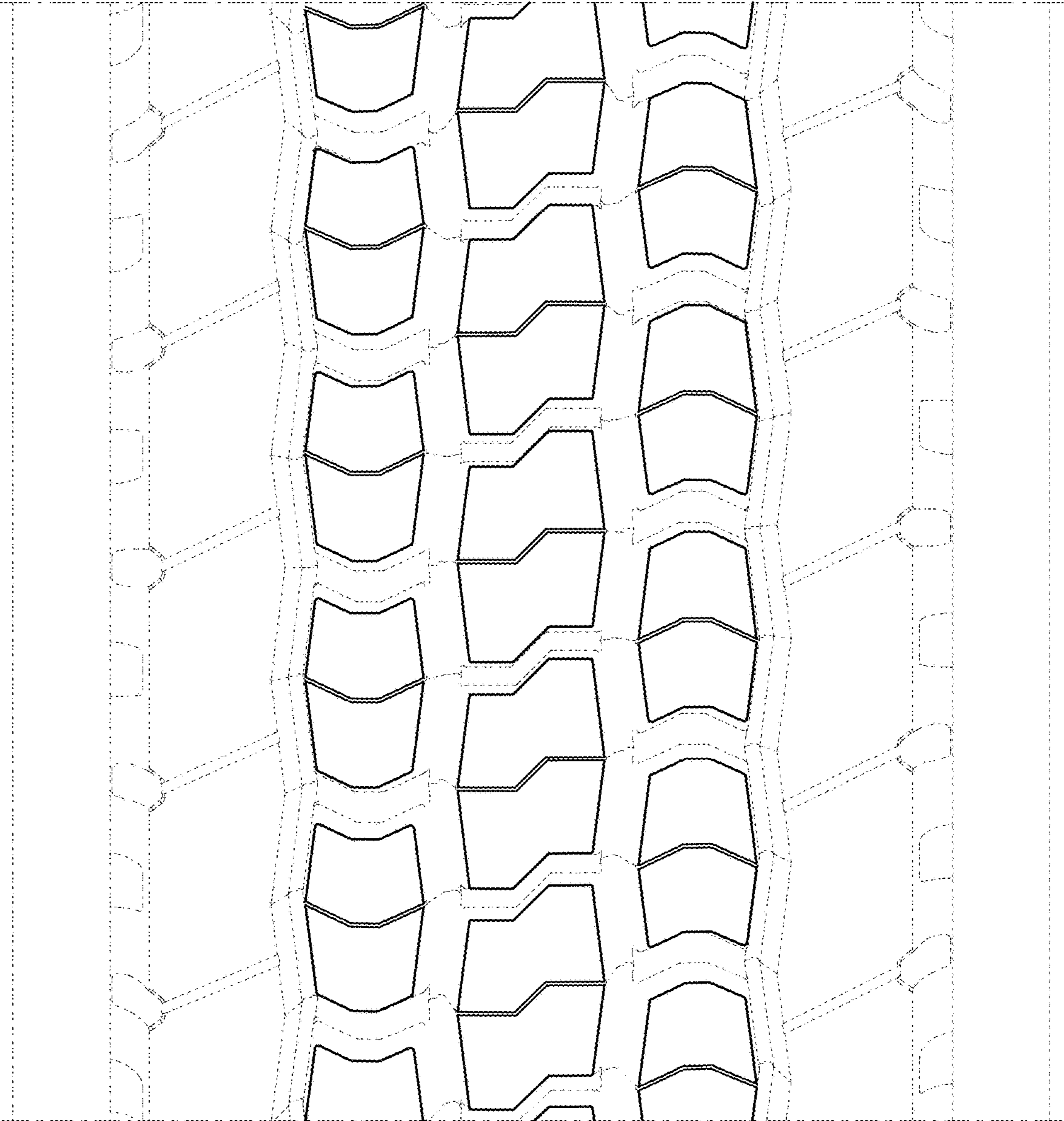

Fig. 3

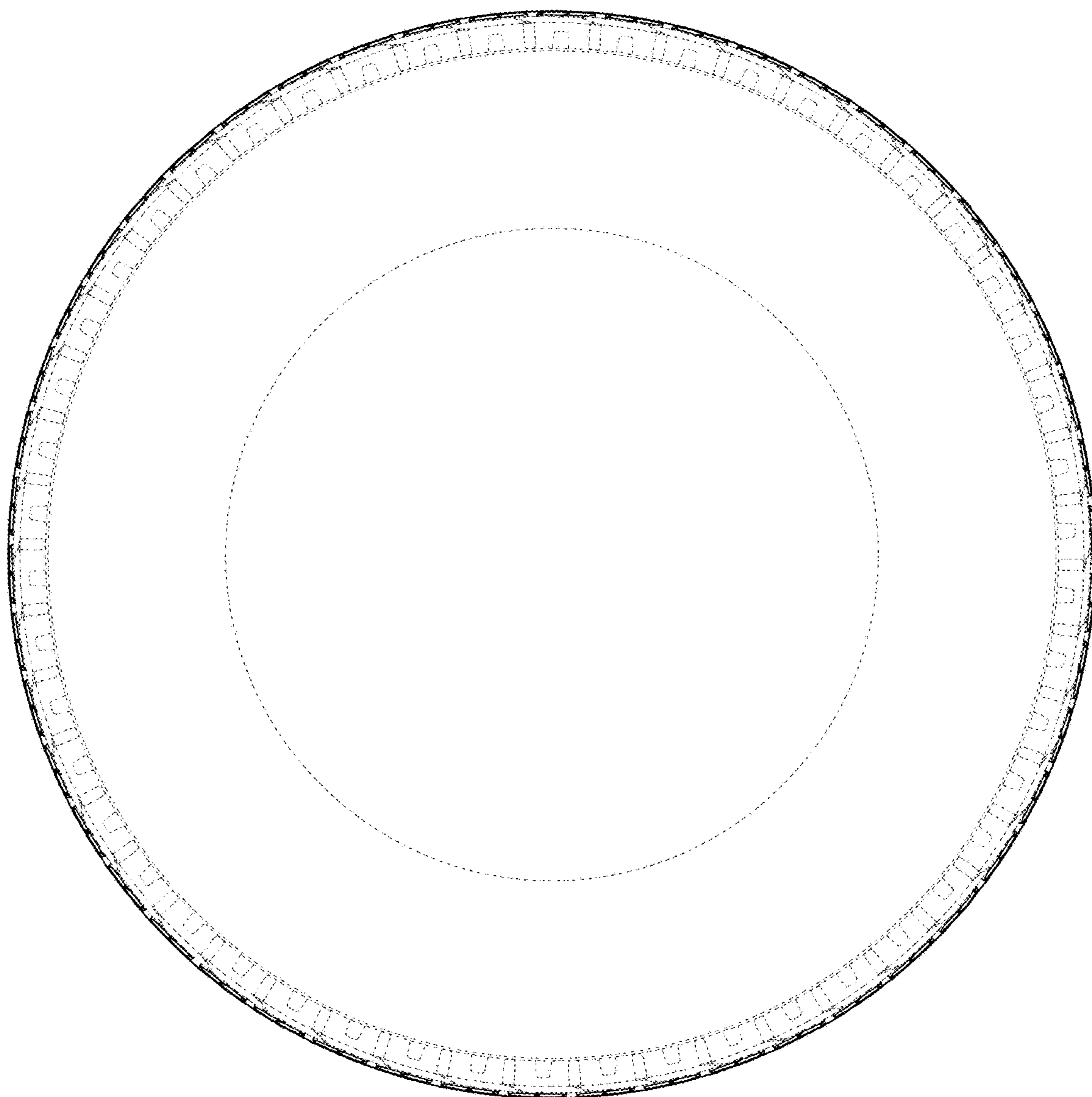

Fig. 4

UNITED STATES PATENT AND TRADEMARK OFFICE
CERTIFICATE OF CORRECTION

PATENT NO. : D798,226 S
APPLICATION NO. : 29/579121
DATED : September 26, 2017
INVENTOR(S) : Richard S. Parr and Aleksandr I. Shmagranoff

Page 1 of 1

It is certified that error appears in the above-identified patent and that said Letters Patent is hereby corrected as shown below:

On the Title Page

The state of the Applicant is incorrectly identified as "OH". It should be "TN".

The Assignee is incorrectly identified as "Bridgestone Americas Tire Operatons, LLC". It should be Bridgestone Americas Tire Operations, LLC.

Signed and Sealed this
Tenth Day of April, 2018

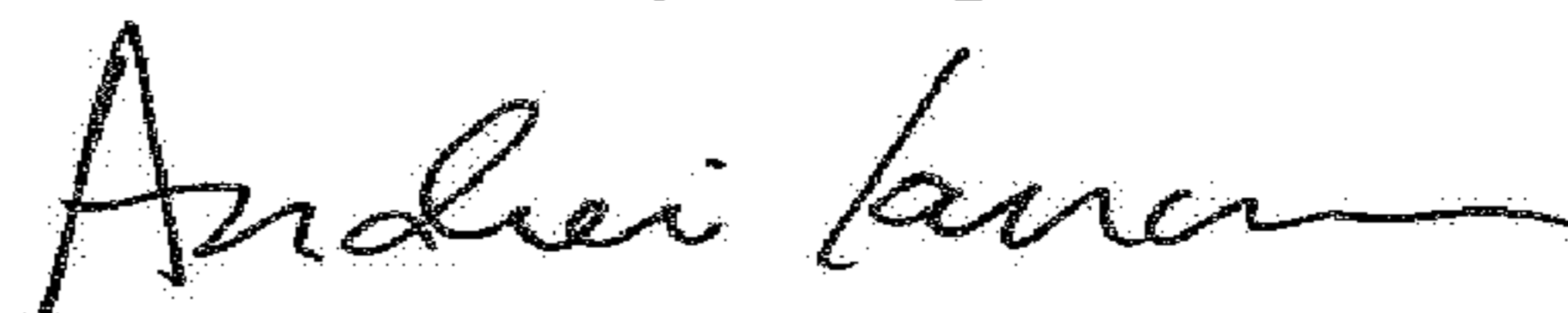

Andrei Iancu
Director of the United States Patent and Trademark Office