



US00D798198S

(12) **United States Design Patent**
Chen

(10) **Patent No.:** **US D798,198 S**

(45) **Date of Patent:** **** Sep. 26, 2017**

(54) **GROUP OF VEHICLE CONTROL ARMS**

8,267,414 B2 * 9/2012 Mesa B60G 7/02
280/124.134

(71) Applicant: **Jacky Chen**, City of Industry, CA (US)

D687,745 S * 8/2013 Pelini D12/159

8,516,673 B1 * 8/2013 Katok B23P 6/00

(72) Inventor: **Jacky Chen**, City of Industry, CA (US)

D713,301 S * 9/2014 Haviland D12/159

2014/0041182 A1 * 2/2014 Katok B23P 11/00

(**) Term: **14 Years**

29/402.08

(21) Appl. No.: **29/521,568**

* cited by examiner

(22) Filed: **Mar. 25, 2015**

Primary Examiner — Darlington Ly

(51) **LOC (10) Cl.** **12-16**

(74) *Attorney, Agent, or Firm* — Che-Yang Chen; Law
Offices of Scott Warmuth

(52) **U.S. Cl.**

(57) **CLAIM**

USPC **D12/159**

The ornamental design for a group of vehicle control arms,
as shown and described.

(58) **Field of Classification Search**

DESCRIPTION

USPC D12/110, 111, 114, 159–161; D15/148;

29/402.7, 402.08; 267/38–53,

267/64.11–64.28, 183–259, 260–291;

280/5.5–5.524; 301/124.1–137

CPC . B23P 6/00; B23P 11/00; B60G 7/001; B60G

7/02; B60G 7/005

See application file for complete search history.

FIG. 1 is a top and front perspective view of a group of
vehicle control arms showing my new design;

FIG. 2 is a front elevational view thereof;

FIG. 3 is a rear elevational view thereof;

FIG. 4 is a right side elevational view thereof;

FIG. 5 is a left side elevational thereof;

FIG. 6 is a bottom plan view thereof; and,

FIG. 7 is a top plan view thereof.

The broken lines in the drawings illustrate portions of the
group of vehicle control arms that form no part of the
claimed design.

(56) **References Cited**

U.S. PATENT DOCUMENTS

D58,959 S * 9/1921 Wendland D12/159

D223,024 S * 2/1972 Thomas D12/159

D402,617 S * 12/1998 Adams, III D12/160

D545,246 S * 6/2007 Kroeker D12/159

D610,952 S * 3/2010 Noble D12/159

1 Claim, 3 Drawing Sheets

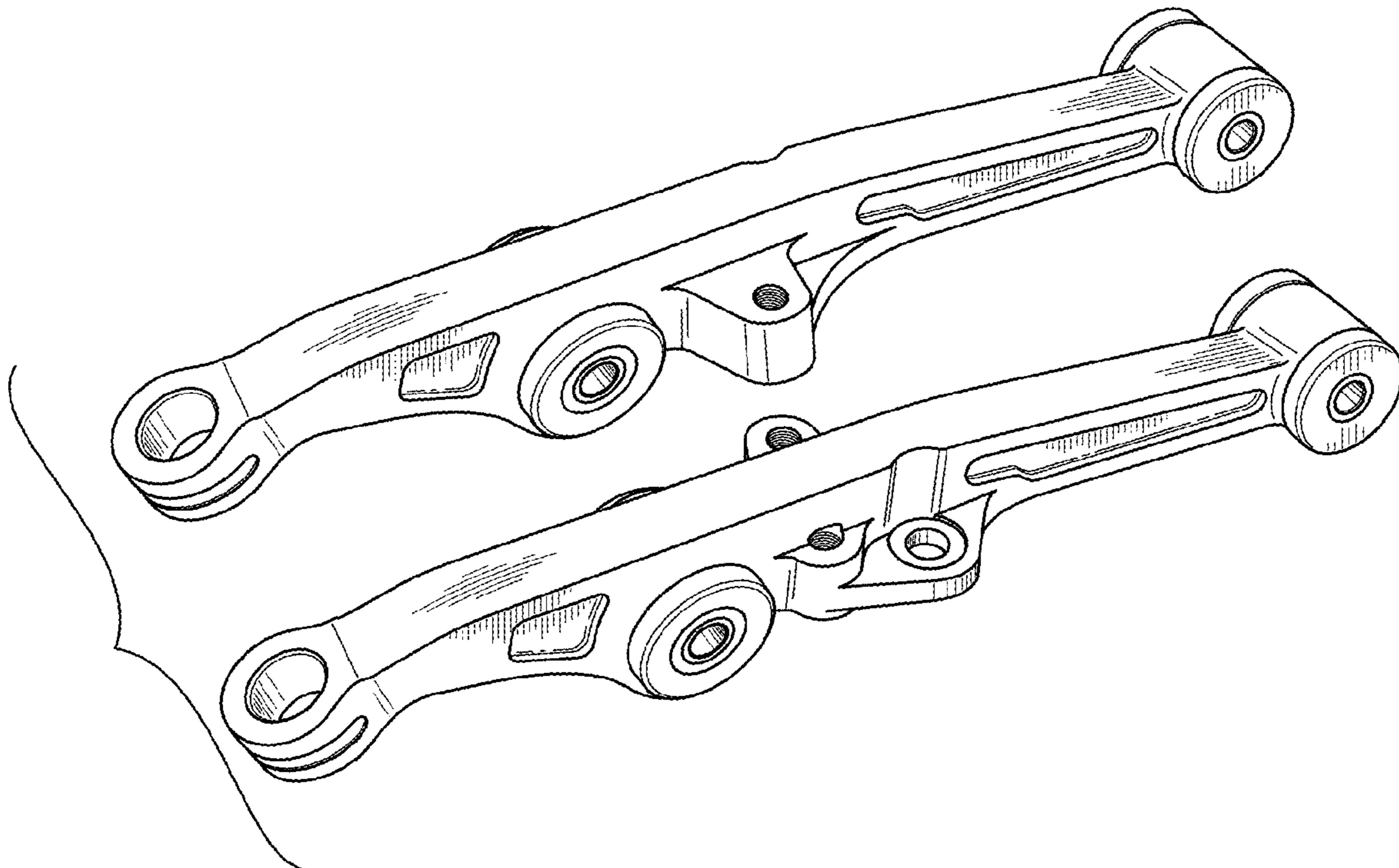

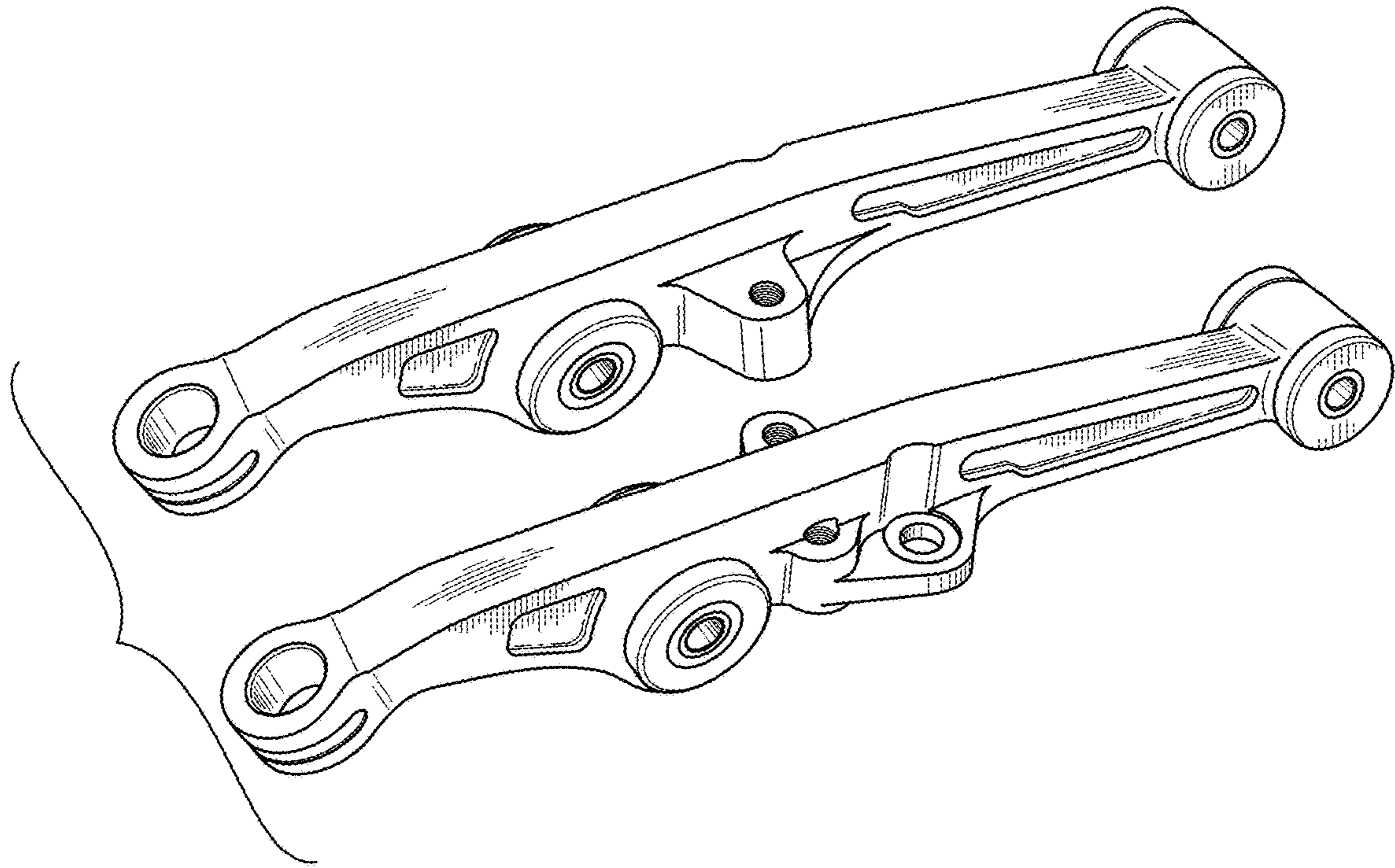

FIG. 1

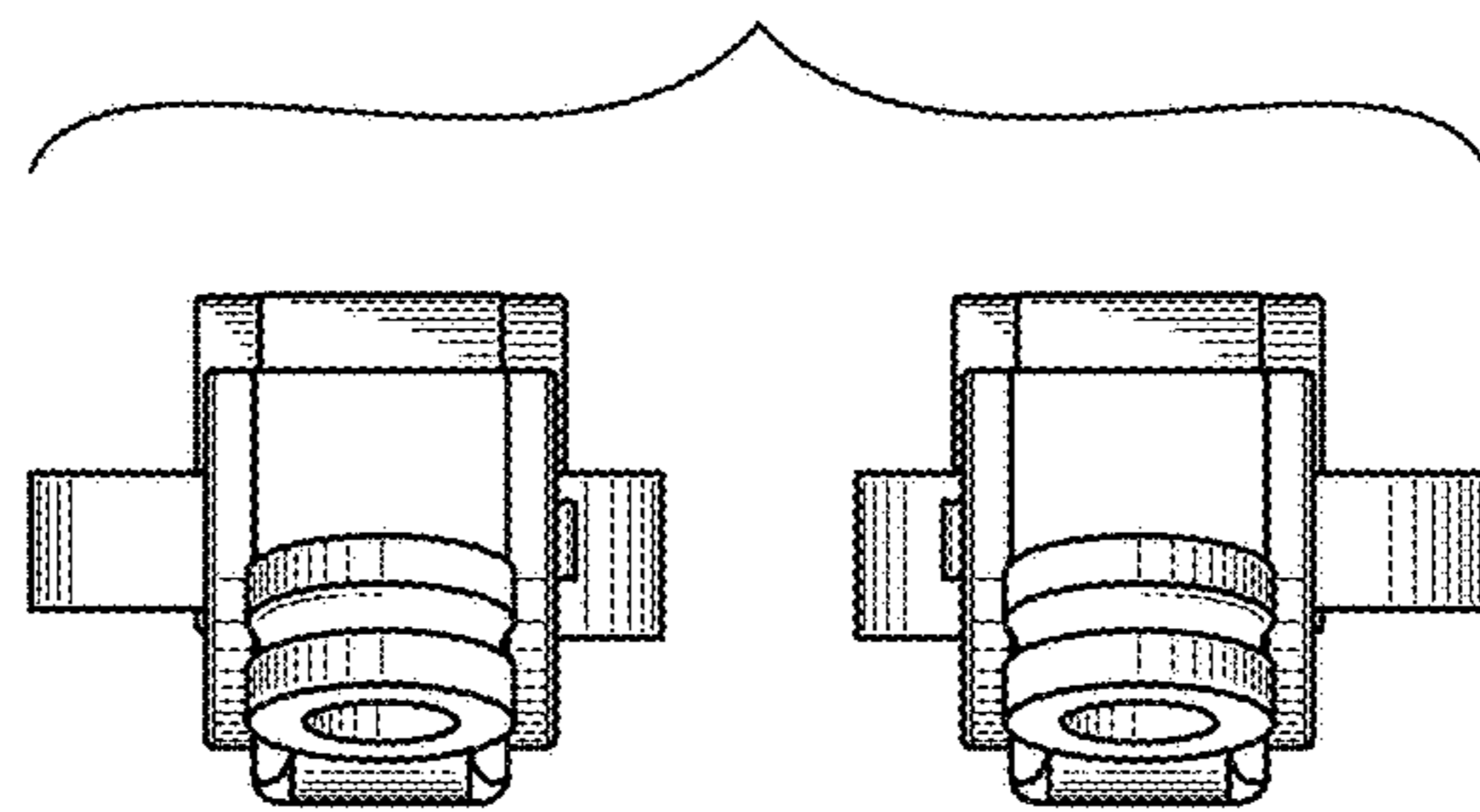

FIG. 2

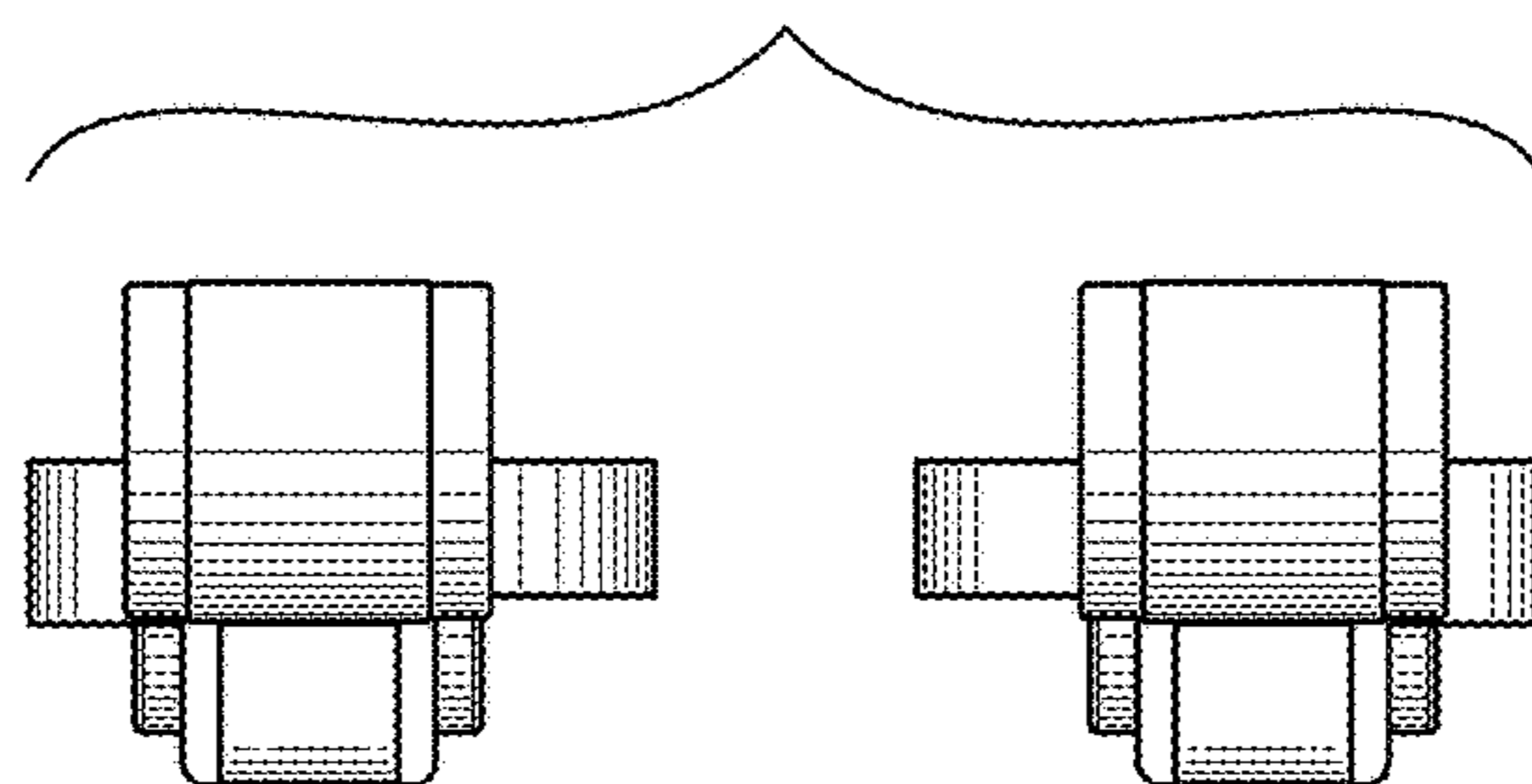

FIG. 3

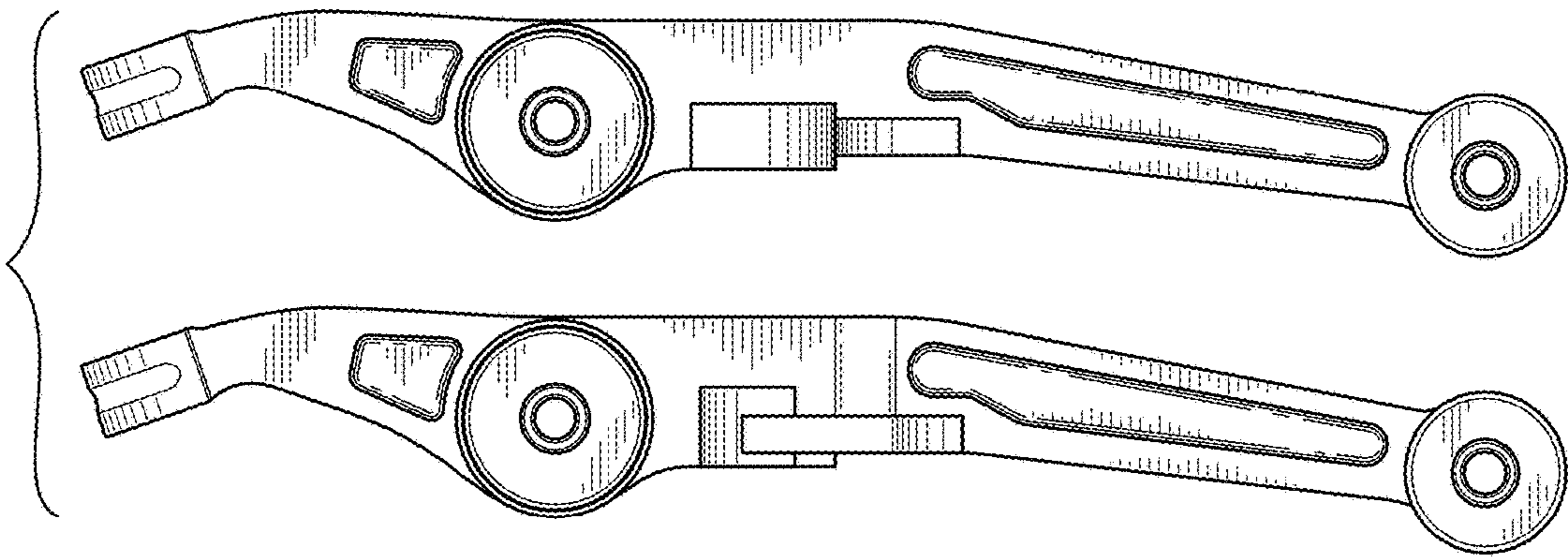

FIG. 4

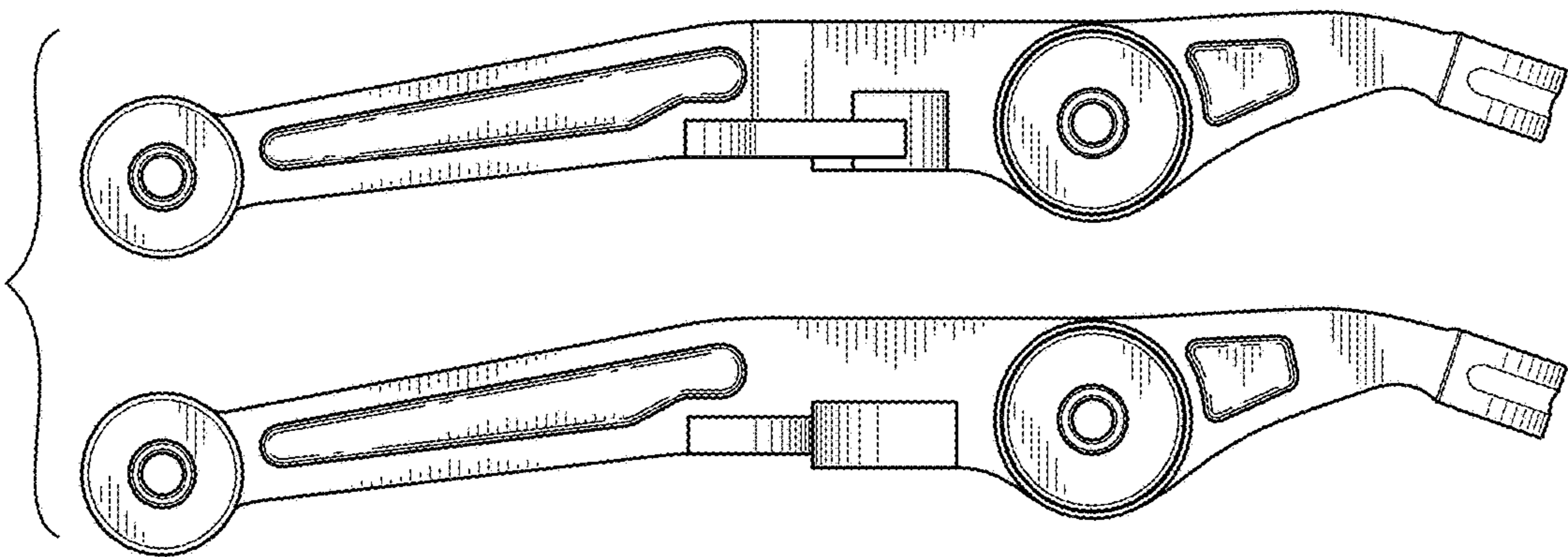

FIG. 5

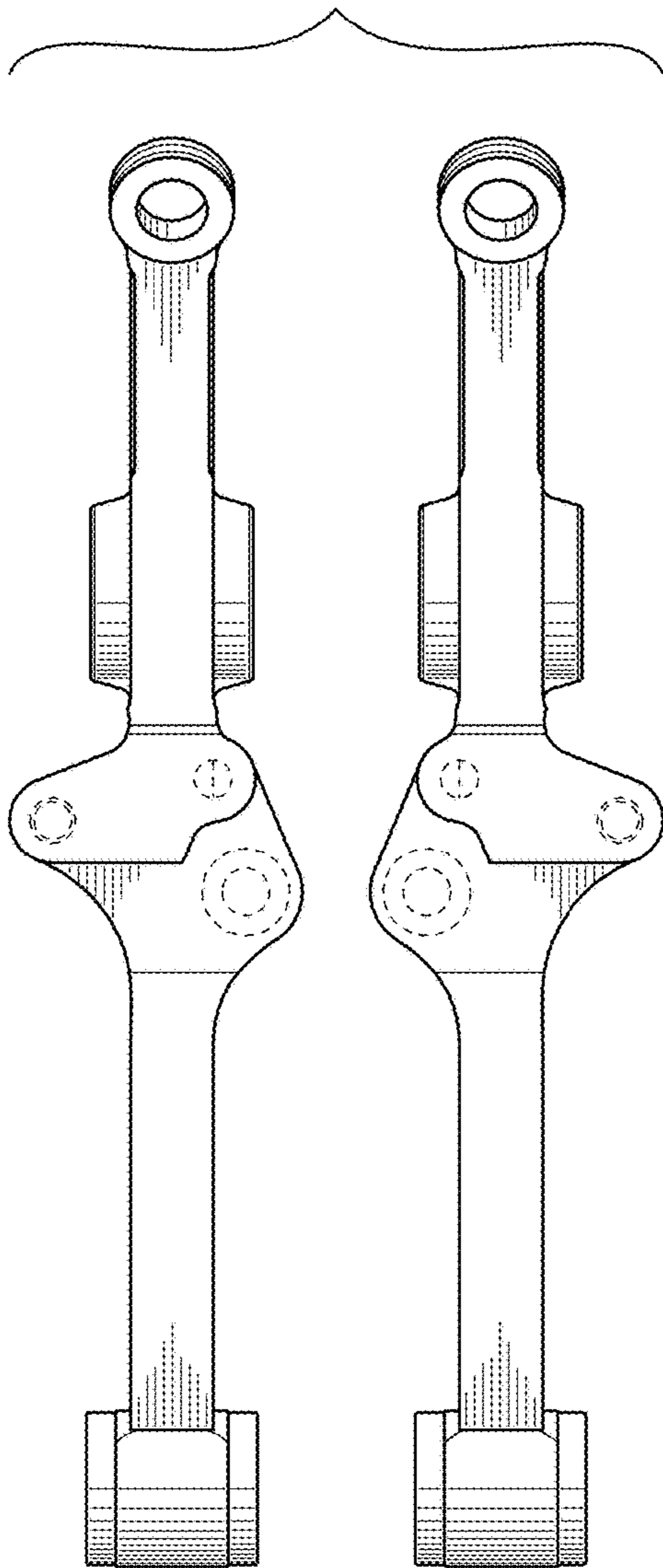

FIG. 6

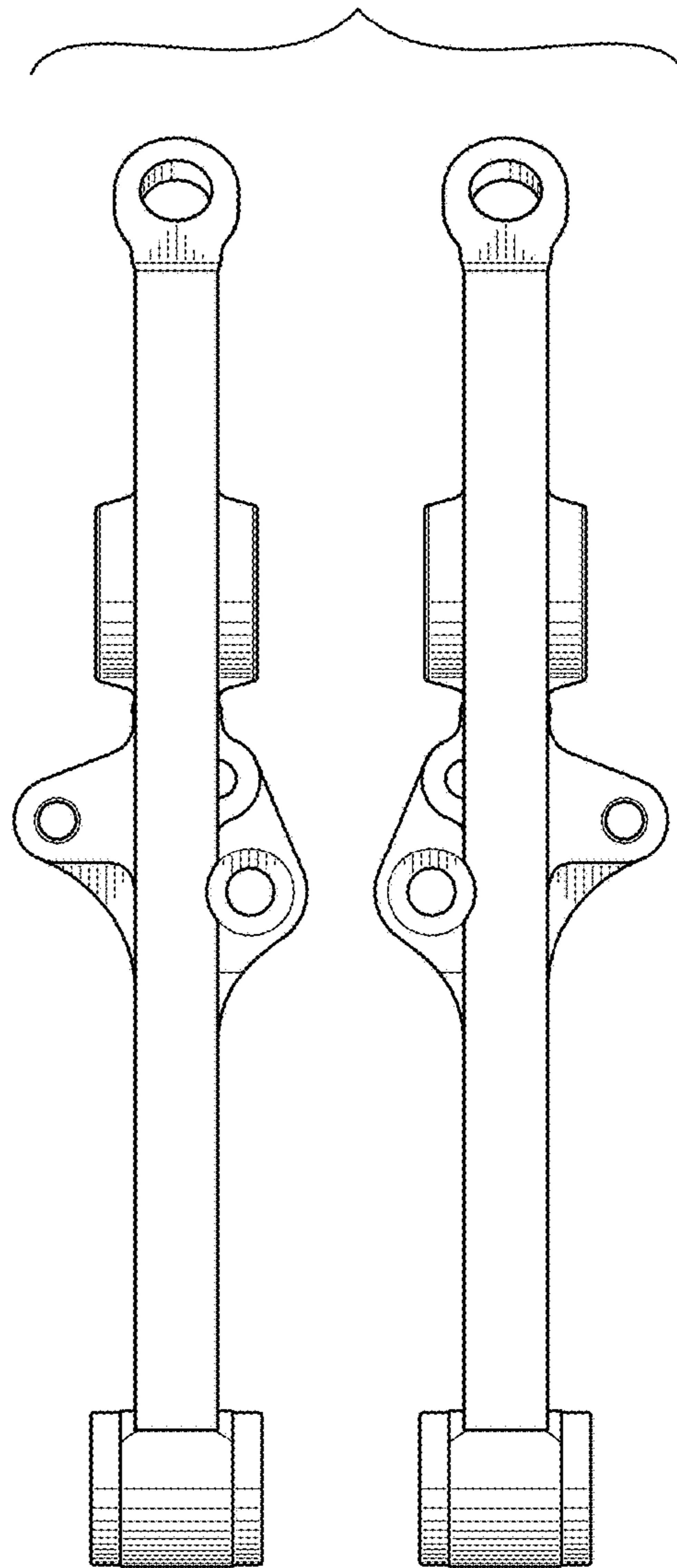

FIG. 7