



US00D797967S

(12) **United States Design Patent** (10) **Patent No.:** **US D797,967 S**
Barry (45) **Date of Patent:** **** Sep. 19, 2017**

(54) **VEHICLE REAR TAILLAMP**
(71) Applicant: **GM GLOBAL TECHNOLOGY OPERATIONS LLC**, Detroit, MI (US)
(72) Inventor: **Adam H. Barry**, Davisburg, MI (US)
(73) Assignee: **GM Global Technology Operations LLC**, Detroit, MI (US)
(**) Term: **15 Years**
(21) Appl. No.: **29/552,667**
(22) Filed: **Jan. 25, 2016**
(51) **LOC (10) Cl.** **26-07**
(52) **U.S. Cl.**
USPC **D26/28**
(58) **Field of Classification Search**
USPC D26/28-36; 362/459-468, 475-478, 362/485-487
CPC F21S 48/00; F21S 48/10; F21S 48/115; F21S 48/225; F21S 48/1233; F21S 48/1266; F21S 48/1388; F21S 48/2268; F21V 21/04
See application file for complete search history.

D605,978 S 12/2009 Wolff et al.
D608,249 S 1/2010 Peters
D608,690 S 1/2010 Folden et al.
D608,691 S 1/2010 Zak, Jr. et al.
D609,608 S 2/2010 Boniface et al.
D611,387 S 3/2010 Thompson et al.
D611,879 S 3/2010 Kim et al.
D612,297 S 3/2010 Peters et al.
D613,645 S 4/2010 Song et al.
D615,458 S 5/2010 Thompson et al.
D618,595 S 6/2010 Ware et al.
D623,090 S 9/2010 Cox et al.
D627,262 S 11/2010 Ikeda et al.
D635,488 S 4/2011 Phipps
D644,147 S 8/2011 Suh et al.
D644,567 S 9/2011 Kozub
D657,718 S 4/2012 Zipfel et al.
D659,052 S 5/2012 Ware et al.
D659,053 S 5/2012 Ware et al.
D668,182 S 10/2012 Barba Franco et al.
D668,183 S 10/2012 Smart
D678,820 S 3/2013 Son et al.
D678,821 S 3/2013 Ikeda et al.
D680,909 S 4/2013 Munson et al.
D680,910 S 4/2013 David
D684,711 S * 6/2013 Chen D26/28

(Continued)

Primary Examiner — Angela J Lee
(74) *Attorney, Agent, or Firm* — Reising Ethington P.C.

(56) **References Cited**

U.S. PATENT DOCUMENTS

D542,442 S * 5/2007 Matsunami D26/28
D570,742 S 6/2008 Takagi et al.
D592,105 S 5/2009 Dean et al.
D597,447 S 8/2009 Folden
D600,595 S 9/2009 Nakamura et al.
D601,925 S 10/2009 O'Donnell
D603,755 S 11/2009 Peters
D604,203 S 11/2009 O'Donnell
D605,082 S 12/2009 Munson
D605,083 S 12/2009 Manoogian, II et al.
D605,977 S 12/2009 Zipfel et al.

(57) **CLAIM**

The ornamental design for a vehicle rear taillamp, as shown and described.

DESCRIPTION

FIG. 1 is a perspective view of the vehicle rear taillamp; FIG. 2 is a front view thereof; FIG. 3 is a side view thereof; and, FIG. 4 is a top view thereof. In the drawings, the portions shown by broken lines form no part of the claimed design.

1 Claim, 2 Drawing Sheets

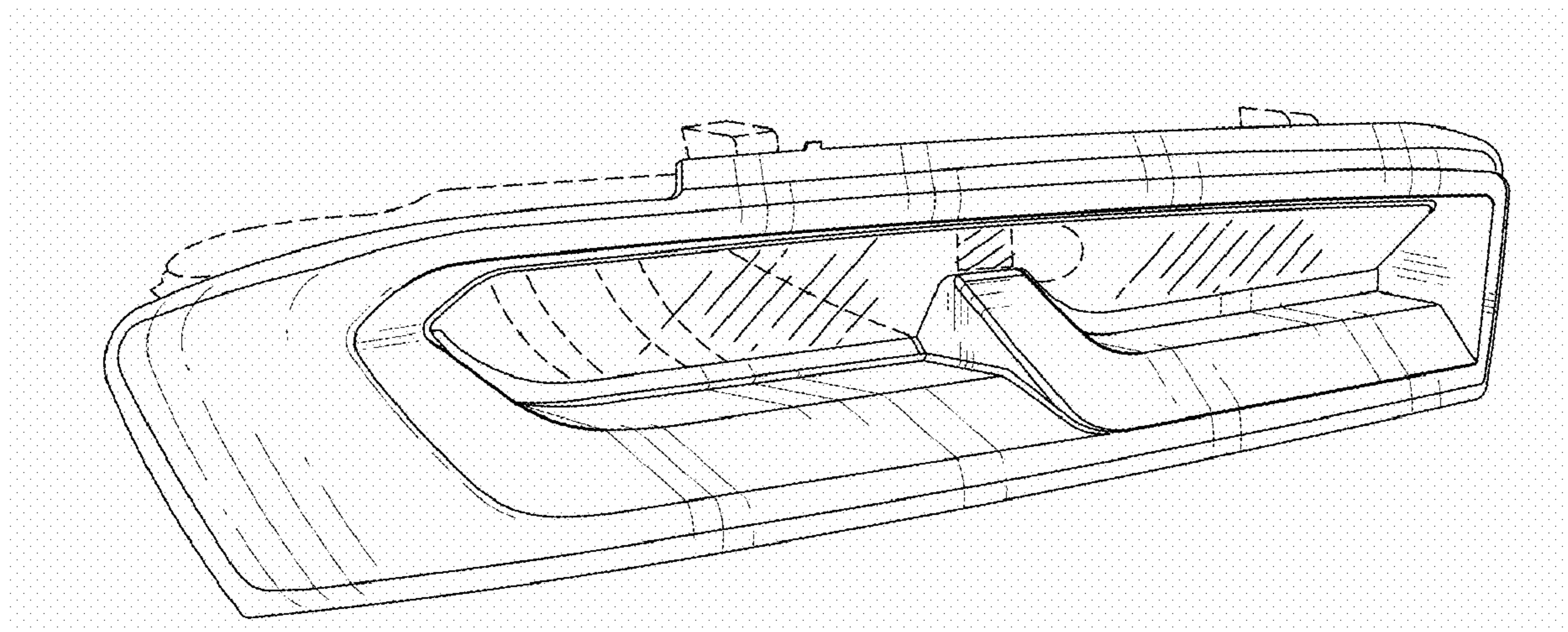

(56)

References Cited

U.S. PATENT DOCUMENTS

D684,899 S	6/2013	Baker		D732,431 S	6/2015	Loeb	
D686,536 S	7/2013	McCabe et al.		D732,432 S	6/2015	Aengenheyster	
D692,798 S	11/2013	Thurber		D732,433 S	6/2015	Aengenheyster	
D692,799 S	11/2013	Smith et al.		D732,435 S	6/2015	Mackay	
D696,157 S	12/2013	Loeb		D733,002 S	6/2015	Loeb	
D699,629 S	2/2014	Ikeda et al.		D735,611 S	8/2015	Aengenheyster	
D700,871 S	3/2014	O'Donnell et al.		D735,627 S	8/2015	Smith	
D701,631 S *	3/2014	Goto	D26/28	D736,451 S	8/2015	Smith	
D703,103 S	4/2014	Lee		D739,306 S	9/2015	McMahan et al.	
D704,103 S	5/2014	Mack et al.		D739,317 S	9/2015	McMahan et al.	
D704,366 S *	5/2014	Saracoglu	D26/28	D741,223 S	10/2015	Kim et al.	
D705,132 S	5/2014	Ware et al.		D743,309 S	11/2015	Thole et al.	
D705,699 S	5/2014	Ware et al.		D743,313 S	11/2015	Smith et al.	
D711,025 S *	8/2014	Gueler	D26/28	D743,314 S	11/2015	Thole et al.	
D713,298 S	9/2014	Dyson		D743,857 S	11/2015	McMahan et al.	
D713,764 S	9/2014	Ferlazzo et al.		D744,158 S	11/2015	Willett et al.	
D716,696 S	11/2014	Thole et al.		D745,086 S	12/2015	Finos et al.	
D716,706 S	11/2014	Thole et al.		D745,719 S	12/2015	Boniface et al.	
D716,709 S	11/2014	Thole et al.		D745,725 S	12/2015	McMahan et al.	
D717,696 S	11/2014	Thole et al.		D745,726 S	12/2015	McMahan et al.	
D718,189 S	11/2014	Krieg et al.		D745,837 S	12/2015	Smith et al.	
D718,683 S	12/2014	Thole et al.		D746,726 S	1/2016	Smith et al.	
D720,872 S *	1/2015	Lim	D26/28	D746,727 S	1/2016	Smith et al.	
D722,282 S	2/2015	Loeb		D746,728 S	1/2016	Smith et al.	
D722,533 S	2/2015	Thole et al.		D746,729 S	1/2016	Boniface et al.	
D722,534 S	2/2015	Munson et al.		D746,730 S	1/2016	Kim et al.	
D724,510 S	3/2015	McMahan et al.		D747,514 S	1/2016	McMahan et al.	
D725,001 S	3/2015	McMahan et al.		D747,515 S	1/2016	McMahan et al.	
D726,591 S	4/2015	Jacob		D747,819 S	1/2016	Thole et al.	
D730,776 S	6/2015	Smart		D747,822 S *	1/2016	Tsai	D26/28
D730,783 S	6/2015	Henriques et al.		D770,646 S *	11/2016	Stopka	D26/28
D732,427 S	6/2015	Loeb		D776,313 S *	1/2017	Han	D26/28
D732,429 S	6/2015	Loeb		D780,961 S *	3/2017	Curic	D26/28
D732,430 S	6/2015	Loeb		D781,473 S *	3/2017	Wheel	D26/28
				2014/0160739 A1 *	6/2014	Hiesl	F21V 15/01 362/217.1

* cited by examiner

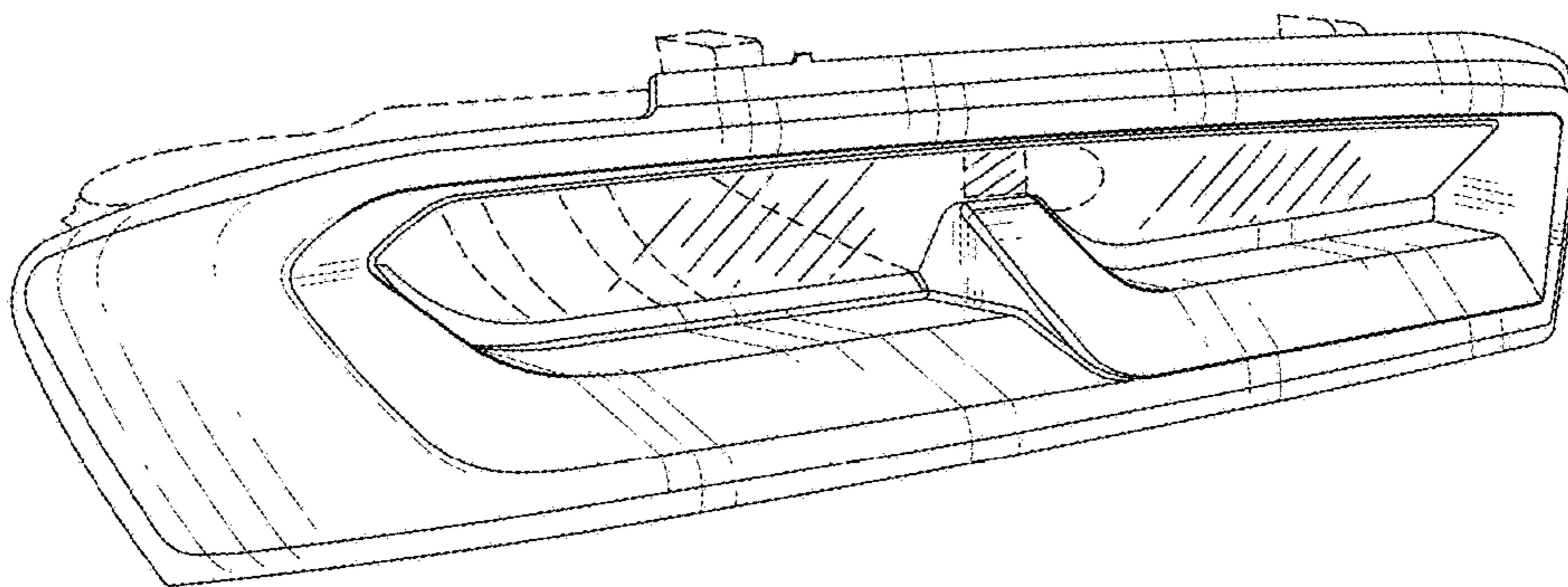

Fig. 1

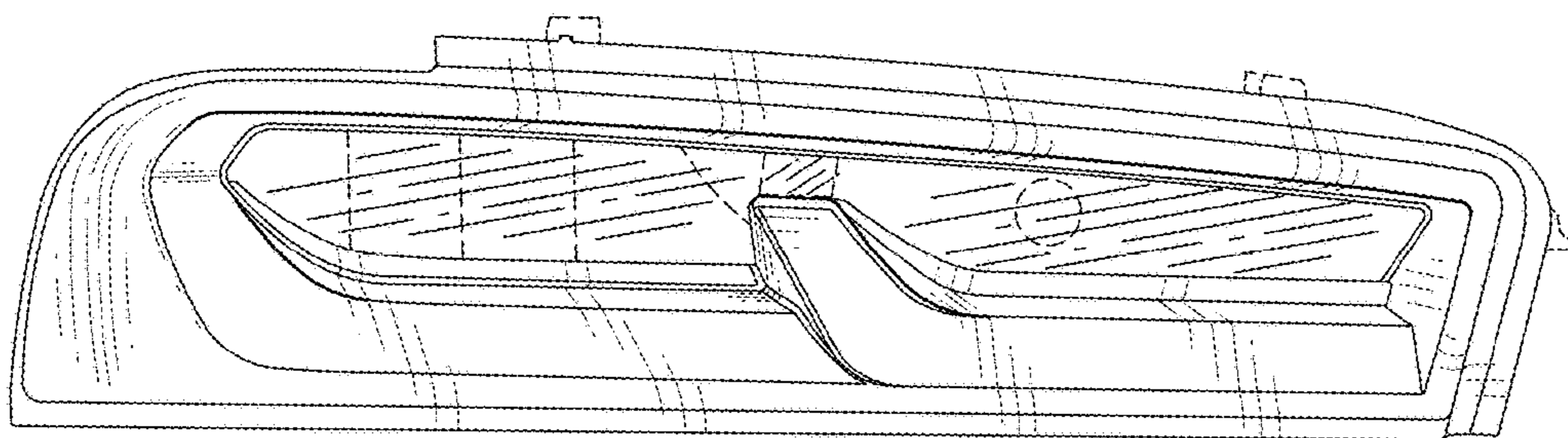

Fig. 2

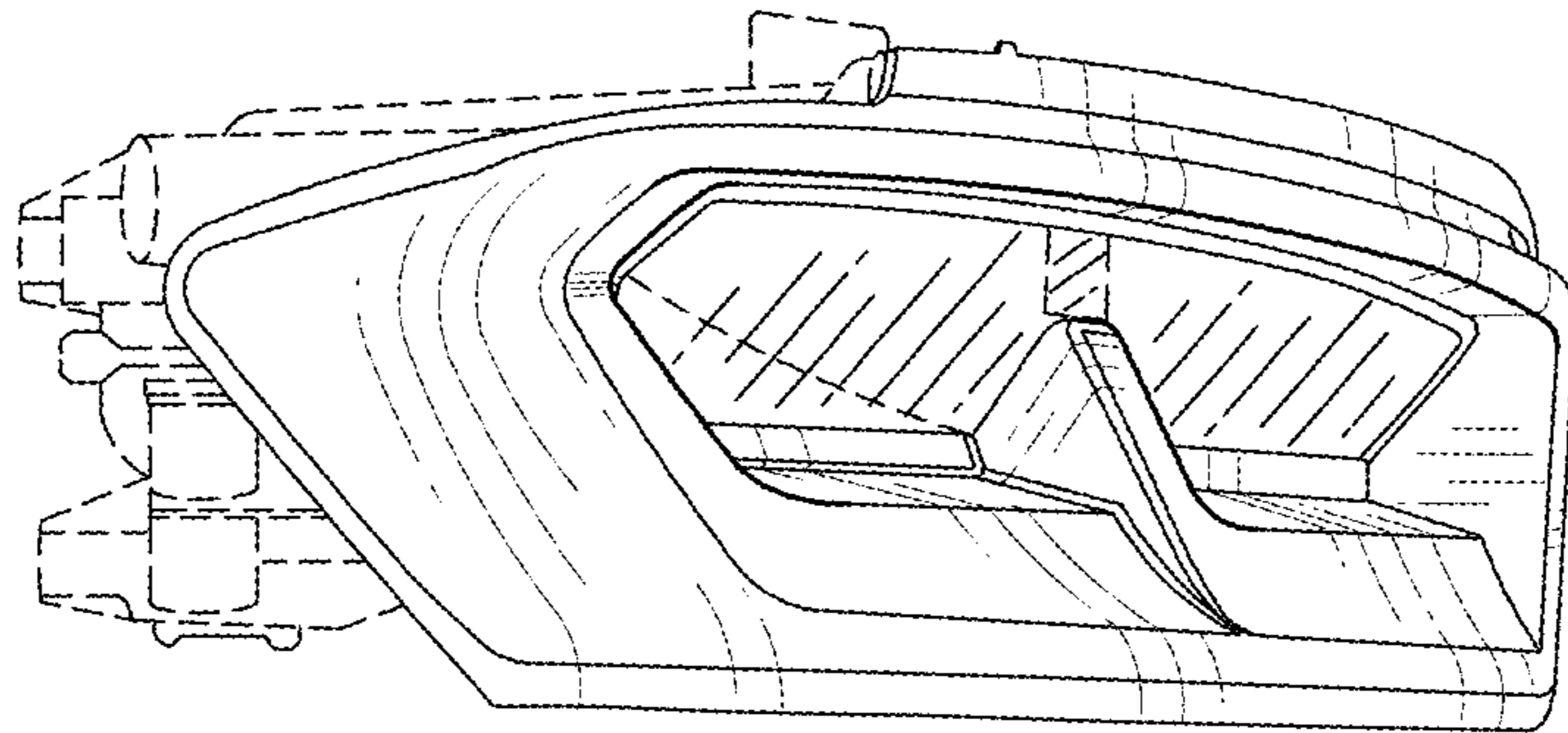

Fig. 3

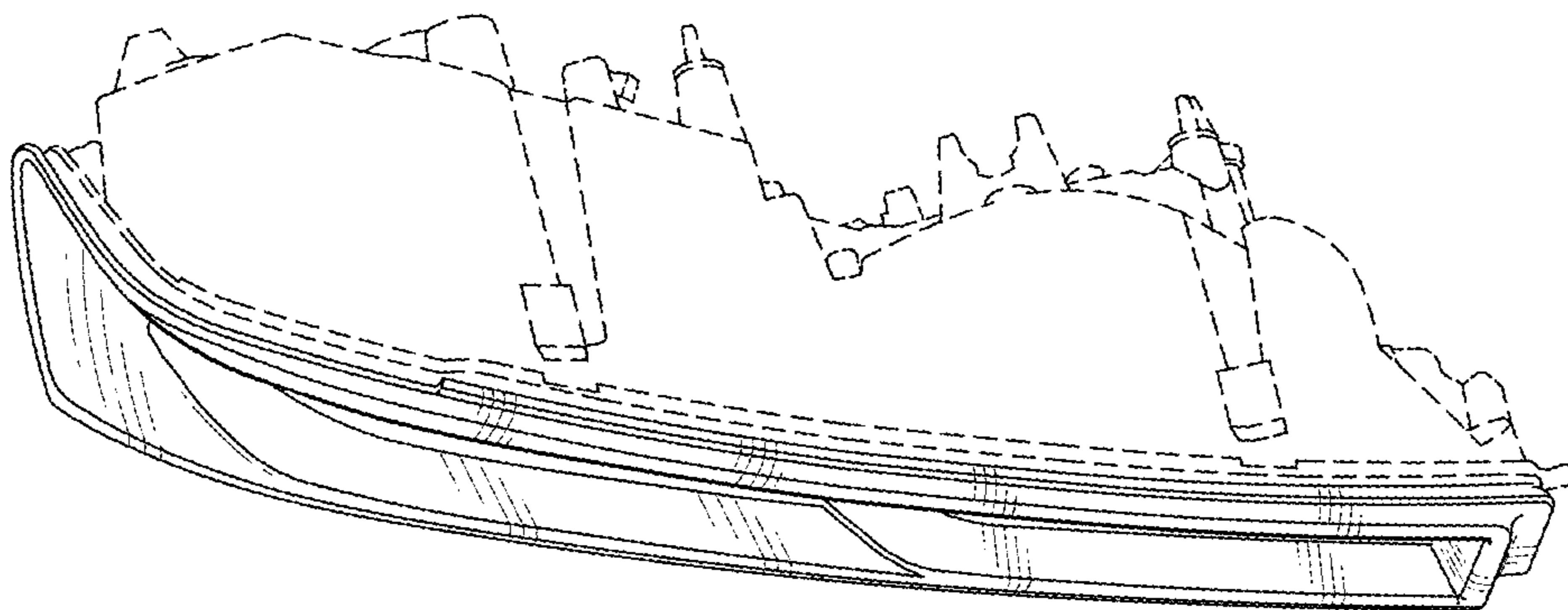

Fig. 4