



US00D797957S

(12) **United States Design Patent**  
**Larson**

(10) **Patent No.:** **US D797,957 S**  
(45) **Date of Patent:** **\*\* Sep. 19, 2017**

(54) **FLOOR UNDERLAYMENT**

(71) Applicant: **PROGRESS PROFILES SPA**, Asolo (TV) (IT)

(72) Inventor: **David D. Larson**, Golden, CO (US)

(73) Assignee: **PROGRESS PROFILES S.P.A.** (IT)

(\*\*) Term: **15 Years**

(21) Appl. No.: **29/547,874**

(22) Filed: **Dec. 8, 2015**

**Related U.S. Application Data**

(60) Division of application No. 29/493,206, filed on Jun. 6, 2014, which is a continuation of application No. 12/550,111, filed on Aug. 28, 2009, now Pat. No. 9,188,348.

(51) **LOC (10) Cl.** ..... **25-01**

(52) **U.S. Cl.**  
USPC ..... **D25/160**

(58) **Field of Classification Search**  
USPC ..... D25/138, 139, 140, 141, 143, 144, 145, D25/146, 147, 148, 149, 151, 152, 153, D25/154, 155, 156, 157, 158, 159, 160, D25/161, 162, 163, 142, 115, 118; D5/1, D5/2, 4, 39, 58, 61, 63, 3  
CPC ..... E04B 5/00; E04B 2001/1984; E04B 2001/2484; E04F 15/00; E04F 15/02; E04F 15/02044; E04F 15/0215; E04F 15/18; E04F 15/182; F24D 3/02; F24D 3/12; F24D 3/14; F24D 3/142; F24D 3/149; F24D 13/02; F24D 13/024  
See application file for complete search history.

(56) **References Cited**

**U.S. PATENT DOCUMENTS**

254,269 A \* 2/1882 Brown ..... E01O 5/00 404/34  
1,485,370 A 3/1924 Cumfer

1,549,773 A 8/1925 Hynes  
2,139,512 A \* 12/1938 Nagorny ..... A44C 15/00 428/52

2,956,785 A 10/1960 Richl  
3,135,040 A 6/1964 Watson  
3,235,712 A 2/1966 Watson

(Continued)

**FOREIGN PATENT DOCUMENTS**

CA 1186470 5/1985  
CH 657690 9/1986

(Continued)

**OTHER PUBLICATIONS**

5 Facts You May Not Know About Heated Flooring (on-line), dated Sep. 12, 2015. Retrieved from Internet Aug. 3, 2016, URL: <https://web.archive.org/web/20150912220312/http://www.southcypress.com/v3/articles/heated-flooring.htm> (4 pages).\*

(Continued)

*Primary Examiner* — Vy Koenig

*Assistant Examiner* — Kimberly Barnes

(74) *Attorney, Agent, or Firm* — Sheridan Ross P.C.

(57) **CLAIM**

The ornamental design for a floor underlayment, as shown and described.

**DESCRIPTION**

FIG. 1 is a perspective view of a floor underlayment in accordance with the present invention; FIG. 2 is a top plan view of the invention illustrated in FIG. 1; FIG. 3 is a side elevational view of the invention illustrated in FIG. 1; and, FIG. 4 is a bottom plan view of the invention illustrated in FIG. 1.

**1 Claim, 3 Drawing Sheets**

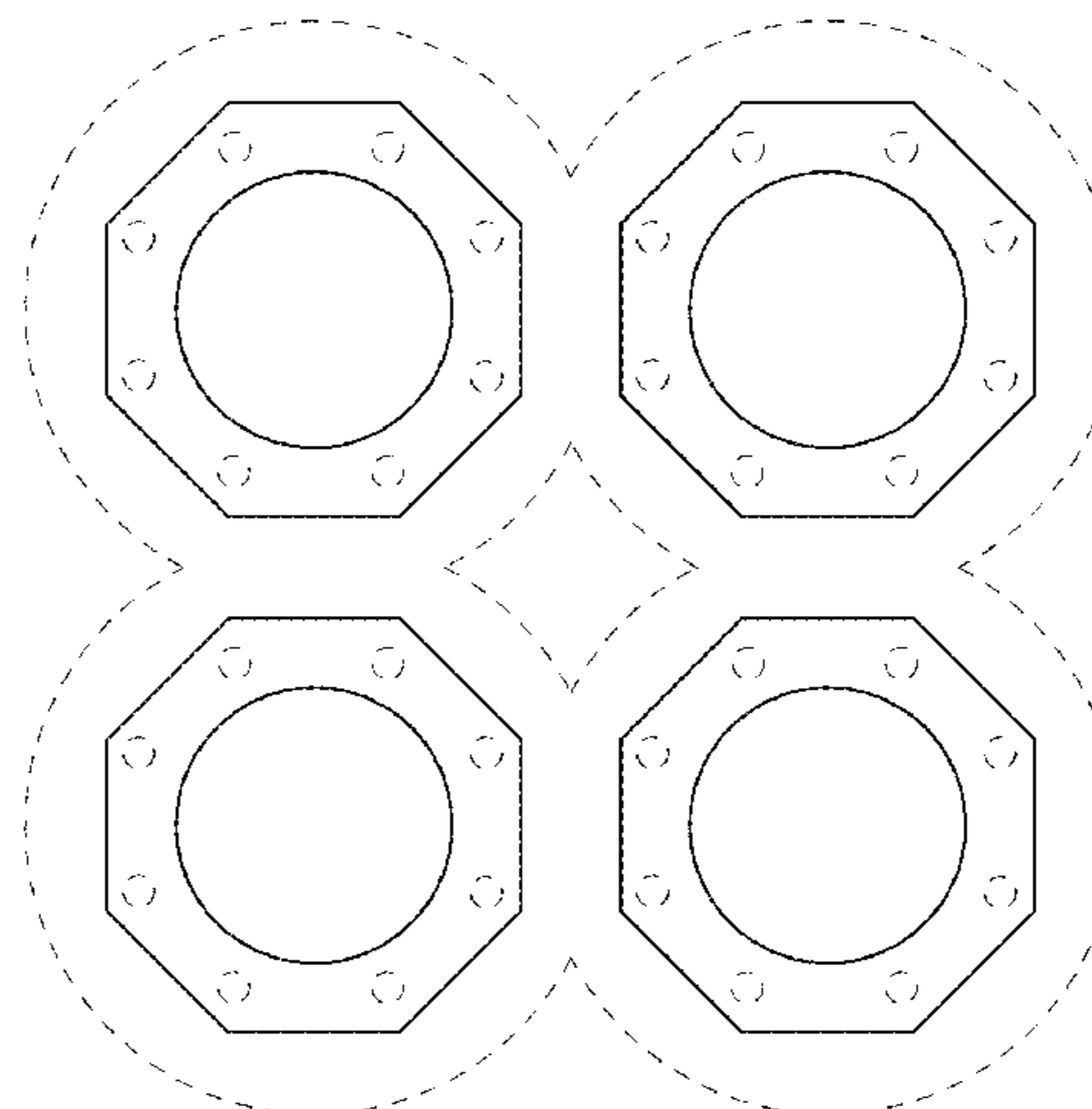
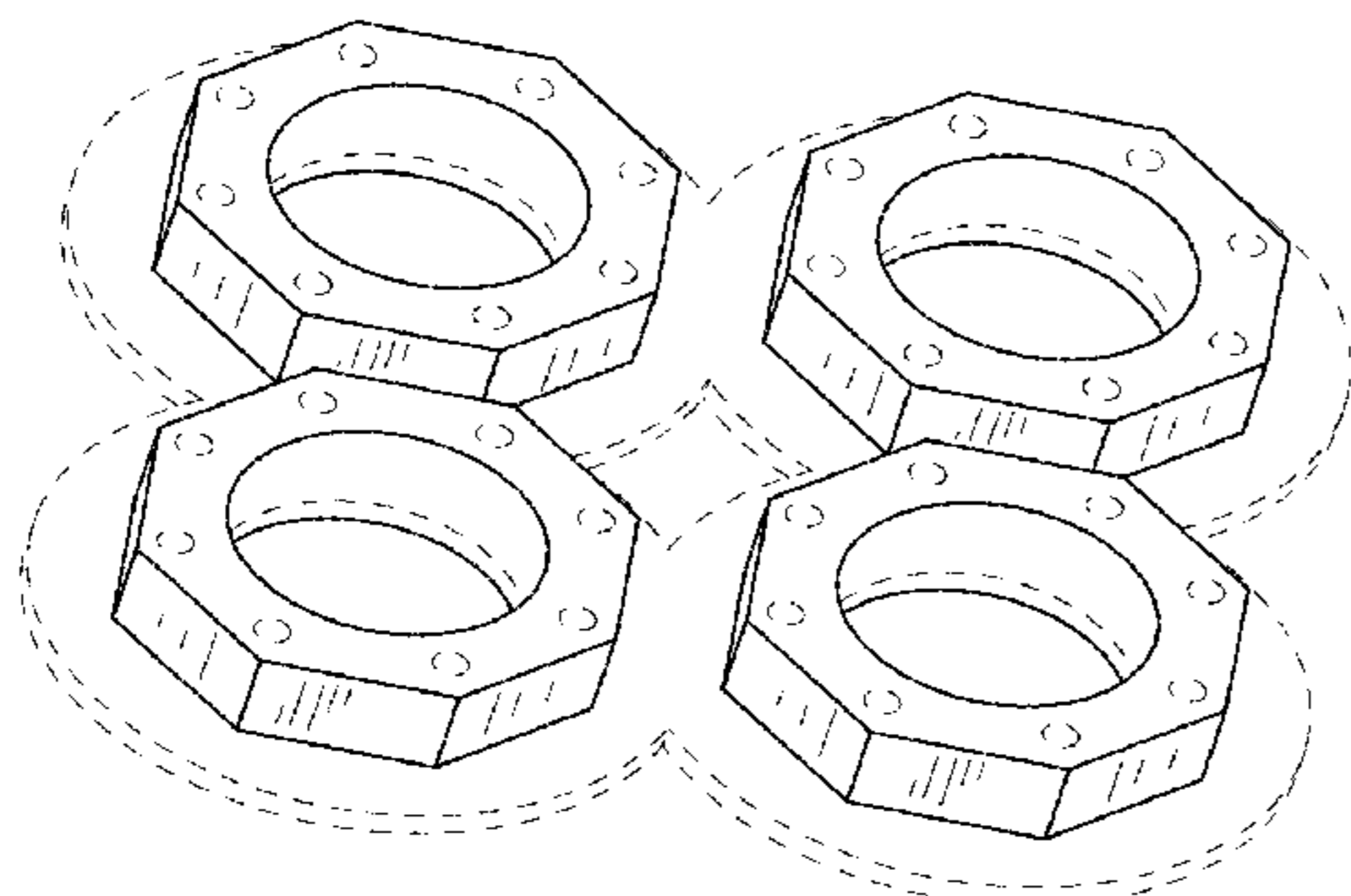

(56)

References Cited

U.S. PATENT DOCUMENTS

3,434,401 A 3/1969 Kiewit  
 3,487,579 A \* 1/1970 Brettingen ..... A63H 33/086  
 446/128  
 3,597,891 A 8/1971 Martin  
 3,695,615 A \* 10/1972 Shoptaugh ..... A63F 3/00574  
 273/157 R  
 3,757,481 A 9/1973 Skinner  
 4,016,692 A 4/1977 Jordan et al.  
 4,183,167 A \* 1/1980 Jatich ..... A63F 9/0073  
 446/118  
 4,250,674 A 2/1981 Feist  
 4,326,366 A 4/1982 Werner  
 4,338,994 A 7/1982 Hewing et al.  
 4,576,221 A 3/1986 Fennesz  
 4,640,067 A 2/1987 Hagemann et al.  
 4,640,854 A 2/1987 Radtke  
 4,923,733 A 5/1990 Herbst  
 4,955,471 A \* 9/1990 Hirose ..... G11B 23/027  
 206/303  
 4,997,308 A \* 3/1991 Welling, Jr. .... E01C 5/00  
 404/38  
 5,042,569 A 8/1991 Siegmund  
 5,052,161 A 10/1991 Whitacre  
 5,078,203 A 1/1992 Shiroki  
 5,105,595 A 4/1992 Tokei et al.  
 5,131,458 A 7/1992 Bourne et al.  
 5,374,466 A 12/1994 Bleasdale  
 5,386,670 A 2/1995 Takeda et al.  
 5,447,433 A \* 9/1995 Perry, Jr. .... G09B 1/06  
 434/171  
 5,480,259 A 1/1996 Thrower  
 5,499,476 A 3/1996 Adams et al.  
 D370,034 S \* 5/1996 Kipfer ..... D21/386  
 D372,158 S \* 7/1996 Bonaddio ..... 5/636  
 5,585,154 A 12/1996 Rhoades  
 5,789,462 A 8/1998 Motani et al.  
 5,863,440 A \* 1/1999 Rink ..... B01D 17/0205  
 210/502.1  
 6,076,315 A 6/2000 Kondo  
 6,094,878 A 8/2000 Schluter  
 6,178,662 B1 \* 1/2001 Legatzke ..... A43B 1/0009  
 36/29  
 6,434,901 B1 8/2002 Schluter  
 6,805,298 B1 10/2004 Corbett  
 6,918,217 B2 7/2005 Jakob-Bamberg et al.  
 D508,332 S 8/2005 Julton  
 D541,396 S 4/2007 Fawcett et al.  
 7,250,570 B1 7/2007 Morand et al.  
 D551,152 S \* 9/2007 Funk ..... D12/217  
 D568,006 S \* 4/2008 Shin ..... D30/146  
 D587,358 S 2/2009 Stephan et al.  
 7,585,556 B2 9/2009 Julton  
 7,669,371 B2 3/2010 Hill  
 8,002,241 B1 \* 8/2011 Shaw ..... B60P 3/36  
 248/346.5  
 8,176,694 B2 5/2012 Batori  
 8,288,689 B1 \* 10/2012 Adelman ..... H05B 3/146  
 219/200  
 8,573,901 B2 \* 11/2013 de Souza Filho ..... B23B 1/00  
 407/107  
 D706,459 S \* 6/2014 Schluter ..... D25/138  
 D712,159 S \* 9/2014 Clerici ..... D5/5  
 8,950,141 B2 \* 2/2015 Schluter ..... E04F 15/182  
 52/385  
 9,188,348 B2 \* 11/2015 Larson ..... F24D 13/024  
 D747,503 S \* 1/2016 Reynolds ..... D25/158  
 9,248,492 B2 \* 2/2016 Sullivan ..... B21D 47/00  
 9,275,622 B2 \* 3/2016 Claeys ..... G10K 11/172  
 9,284,693 B2 \* 3/2016 Tabibnia ..... E01O 5/00  
 9,416,979 B2 \* 8/2016 Larson ..... F24D 13/024  
 2005/0184066 A1 \* 8/2005 Brooks ..... B65D 77/0433  
 219/730  
 2006/0265975 A1 11/2006 Geffe  
 2006/0278172 A1 12/2006 Ragonetti et al.

2007/0056233 A1 3/2007 Kang et al.  
 2008/0017725 A1 1/2008 Backman, Jr.  
 2008/0173060 A1 7/2008 Cymbalisty et al.  
 2008/0276557 A1 11/2008 Rapaz  
 2008/0290503 A1 11/2008 Karavakis et al.  
 2008/0290504 A1 11/2008 Karavakis et al.  
 2008/0295441 A1 12/2008 Carolan et al.  
 2009/0026192 A1 1/2009 Fuhrman  
 2009/0230113 A1 9/2009 Batori  
 2014/0069039 A1 3/2014 Schluter et al.  
 2016/0010327 A1 1/2016 Larson  
 2016/0033144 A1 2/2016 Larson  
 2016/0047131 A1 2/2016 Larson

FOREIGN PATENT DOCUMENTS

DE 2840149 3/1980  
 DE 8413516 10/1984  
 DE 3317131 11/1984  
 DE 3730144 4/1988  
 DE 4201553 11/1992  
 DE 9114591 3/1993  
 DE 4230168 8/1993  
 DE 4226312 2/1994  
 DE 4242026 6/1994  
 DE 19750277 5/1999  
 DE 19828607 12/1999  
 DE 19936801 8/2000  
 DE 19912922 1/2001  
 DE 10040643 11/2001  
 DE 202006013453 11/2006  
 DE 102006004626 8/2007  
 DE 102006004755 8/2007  
 EM 001079214-0005 \* 3/2009  
 EP 60547 9/1982  
 EP 74490 3/1983  
 EP 133556 2/1985  
 EP 189020 7/1986  
 EP 367176 5/1990  
 EP 368804 5/1990  
 EP 437999 7/1991  
 EP 514684 11/1992  
 EP 0582031 2/1994  
 EP 947778 10/1999  
 EP 1054217 11/2000  
 EP 1068413 1/2001  
 EP 1074793 2/2001  
 EP 1096079 5/2001  
 EP 1338413 8/2003  
 EP 1208332 3/2004  
 EP 1770337 4/2007  
 FR 2695986 3/1994  
 FR 2746426 9/1997  
 GB 2006548 5/1979  
 GB 2097836 11/1982  
 GB 2364565 1/2002  
 GB 2373042 9/2002  
 JP H01-139935 6/1989  
 JP H05-264051 10/1993  
 JP 2008-025295 2/2008  
 WO WO 82/03099 9/1982  
 WO WO 95/22671 8/1995  
 WO WO 2004/111544 12/2004

OTHER PUBLICATIONS

Ditra Heat—Glens Falls Tile (on-line), dated Sep. 4, 2014. Retrieved from Internet Aug. 3, 2016, URL: <http://www.glensfallstile.com/general-tips/ditra-heat/772/> (1 page).  
 Official Action for U.S. Appl. No. 29/493,206, mailed Aug. 10, 2016 8 pages.  
 Third Party Submission for U.S. Appl. No. 14/829,108, mailed Aug. 17, 2016, 17 pages.  
 Official Action for U.S. Appl. No. 15/070,960, mailed Aug. 26, 2016 9 pages.  
 Official Action for U.S. Appl. No. 15/185,576, mailed Aug. 24, 2016 14 pages.

(56)

**References Cited**

OTHER PUBLICATIONS

Polypipe Brochure; "Redefining Heating Systems," www.ufch.com;  
Polyplumb: Hot & Cold Plumbing & Heating System; © 2006,  
Polypipe Group; Printed: Feb. 2007, 44 pages.

Third Party Submission for U.S. Appl. No. 14/860,065, filed Jun.  
23, 2016 25 pages.

Third Party Submission for U.S. Appl. No. 14/860,065, filed Jul. 8,  
2016 26 pages.

Notice of Allowance for U.S. Appl. No. 14/860,065, mailed Sep. 14,  
2016 10 pages.

Official Action for U.S. Appl. No. 12/550,111, mailed Apr. 26, 2013  
12 pages.

Official Action for U.S. Appl. No. 12/550,111, mailed Dec. 5, 2013  
14 pages.

Official Action for U.S. Appl. No. 12/550,111, mailed Jan. 23, 2015  
16 pages.

Notice of Allowance for U.S. Appl. No. 12/550,111, mailed Aug. 28,  
2015 11 pages.

Notice of Allowance for U.S. Appl. No. 12/550,111, mailed Sep. 22,  
2015 10 pages.

Official Action for U.S. Appl. No. 14/860,065, mailed Mar. 15,  
2016, 6 pages.

Third Party Submission for U.S. Appl. No. 14/860,065, mailed Apr.  
28, 2016, 18 pages.

Notice of Allowance for U.S. Appl. No. 14/880,859, mailed Mar. 7,  
2016, 16 pages.

Official Action for U.S. Appl. No. 14/829,108, mailed Jan. 20, 2016,  
10 pages.

\* cited by examiner

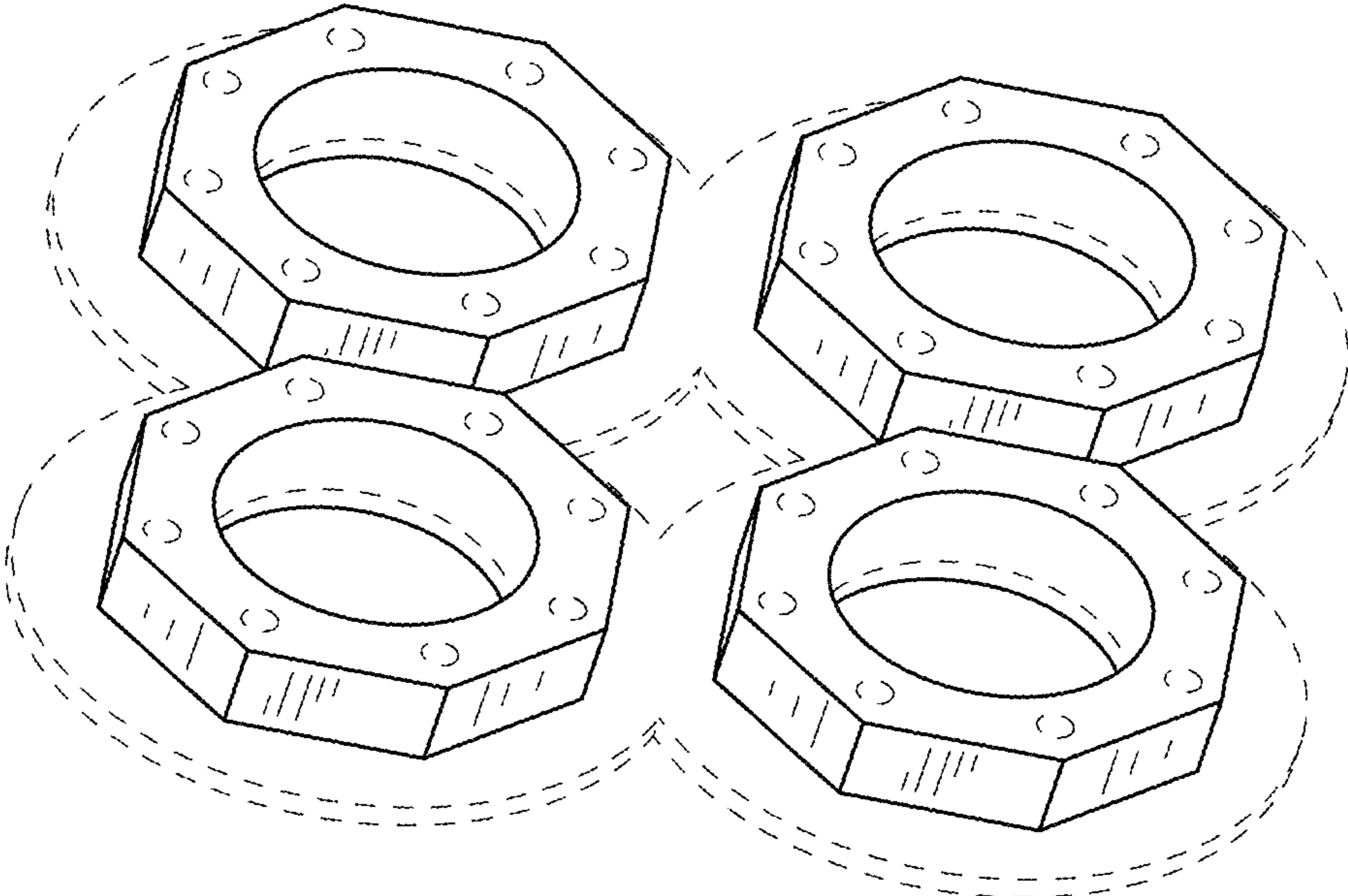

FIG.1

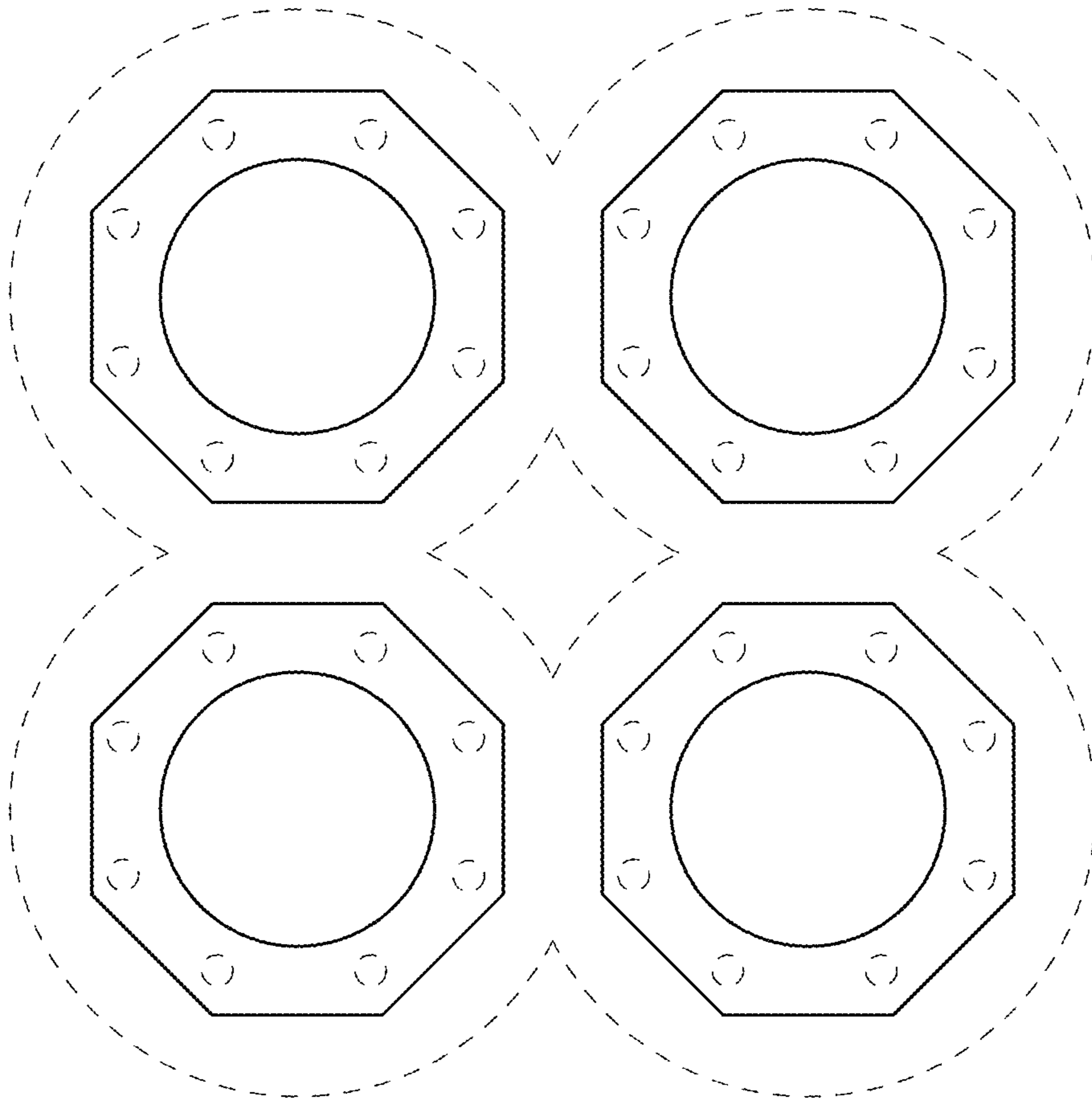

FIG. 2

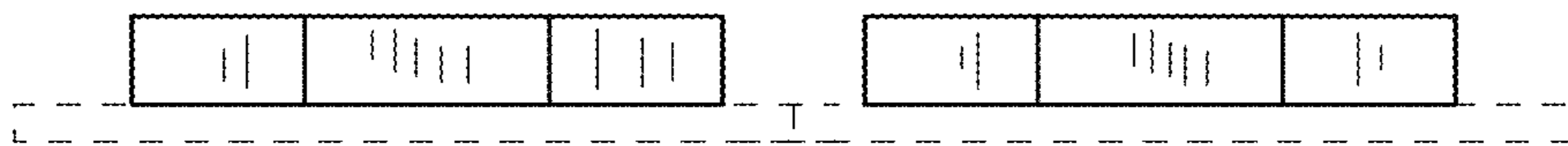

FIG. 3

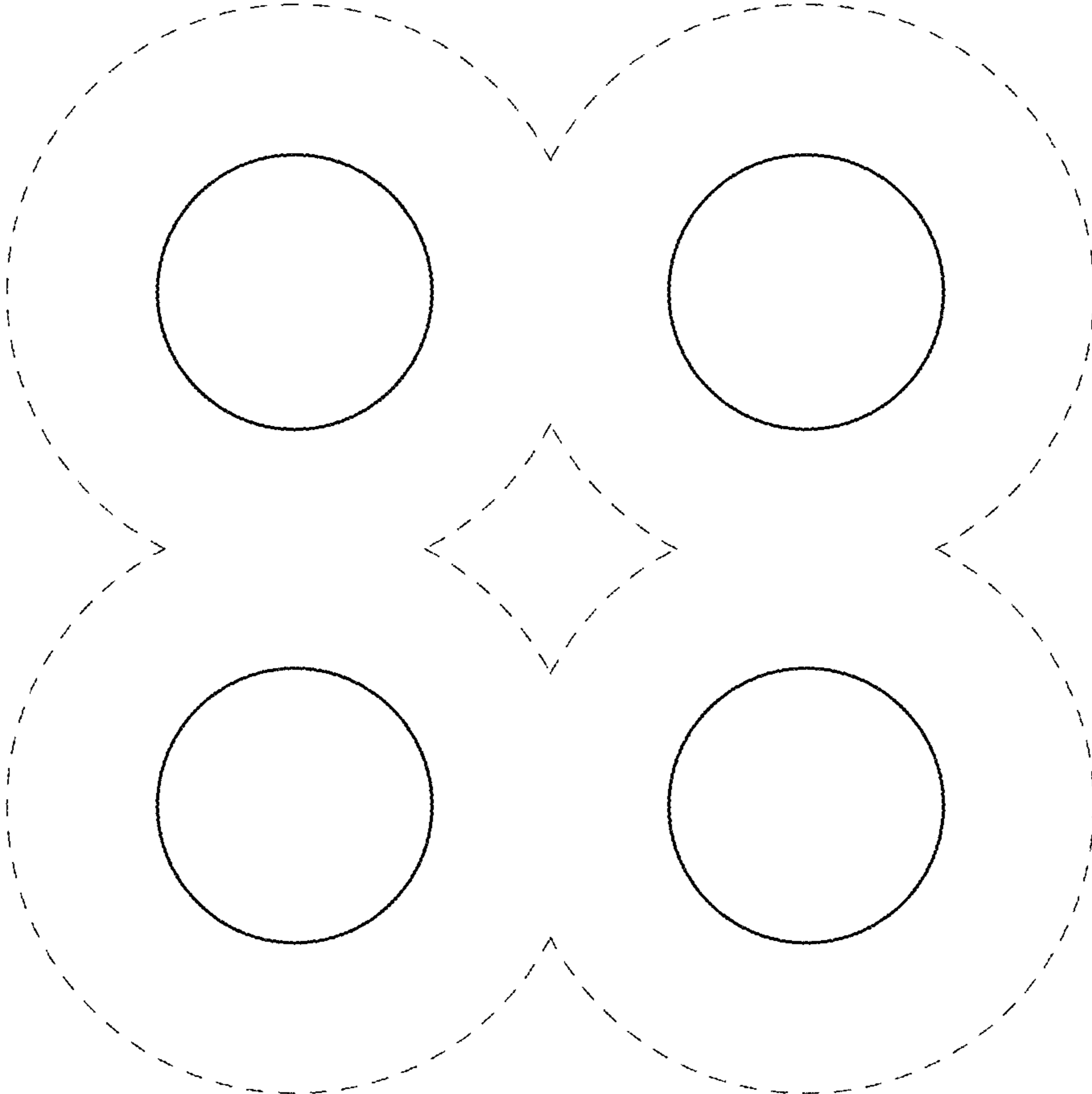

FIG.4