



US00D796481S

(12) **United States Design Patent**
Kuramoto

(10) **Patent No.:** **US D796,481 S**

(45) **Date of Patent:** **** Sep. 5, 2017**

(54) **AUDIO MIXER**

(71) Applicant: **Pioneer DJ CORPORATION**,
Yokohama-shi, Kanagawa (JP)

(72) Inventor: **Takahiro Kuramoto**, Yokohama (JP)

(73) Assignee: **Pioneer DJ CORPORATION**,
Yokohama-shi, Kanagawa (JP)

(**) Term: **15 Years**

(21) Appl. No.: **29/574,775**

(22) Filed: **Aug. 18, 2016**

(51) **LOC (10) Cl.** **14-03**

(52) **U.S. Cl.**
USPC **D14/217**

(58) **Field of Classification Search**
USPC D14/217, 257, 258, 434, 496, 162, 167,
D14/175, 188, 196-198
CPC .. G10H 2210/241; G10H 1/0066; G10H 1/46;
G10H 2240/325; G10H 2250/631; G10H
1/00; G10H 1/0008; G10H 1/0025; G10H
1/0091; G10H 1/125; G10H 2210/051;
G10H 2210/056; G10H 2210/066; G10H
2210/125; G10H 2210/321; G10H
2230/291; G10H 2240/026; G10H
2240/285; G10H 2240/305; G10H
2240/311; G10H 2250/025; G10H
2250/031; G10H 2250/035; G10H
2250/435; G10H 2250/571; G10H
2250/641; G10H 3/146; G10H 5/005;
G10H 7/02; G10H 7/06

See application file for complete search history.

(56) **References Cited**

U.S. PATENT DOCUMENTS

D665,778 S * 8/2012 Langlois D14/217
D680,519 S * 4/2013 Ito D14/217
D692,414 S * 10/2013 Ito D14/217
D717,278 S * 11/2014 Amiya D14/217

D748,607 S * 2/2016 Ito D14/217
D760,196 S * 6/2016 O'Donnell D14/217
D765,620 S * 9/2016 Kitamura D14/217

(Continued)

OTHER PUBLICATIONS

U.S. Appl. No. 29/574,771, filed Aug. 18, 2016, Takahiro Kuramoto.

Primary Examiner — Ian Simmons

Assistant Examiner — Khawaja Anwar

(74) *Attorney, Agent, or Firm* — Drinker Biddle & Reath LLP

(57) **CLAIM**

I claim the ornamental design for an audio mixer, as shown and described.

DESCRIPTION

FIG. 1 is an upper perspective view showing the design at the open state;

FIG. 2 is a lower perspective view thereof;

FIG. 3 is a front view thereof;

FIG. 4 is a rear view thereof;

FIG. 5 is a left-side view thereof;

FIG. 6 is a right-side view thereof;

FIG. 7 is a top view thereof;

FIG. 8 is a bottom view thereof;

FIG. 9 is an upper perspective view showing the design at the closed state;

FIG. 10 is a lower perspective view thereof;

FIG. 11 is a front view thereof;

FIG. 12 is a rear view thereof;

FIG. 13 is a left-side view thereof;

FIG. 14 is a right-side view thereof;

FIG. 15 is a top view thereof; and,

FIG. 16 is a bottom view thereof.

The broken lines shown in the drawings represent unclaimed portions of the audio mixer and form not parts of the claimed design.

1 Claim, 16 Drawing Sheets

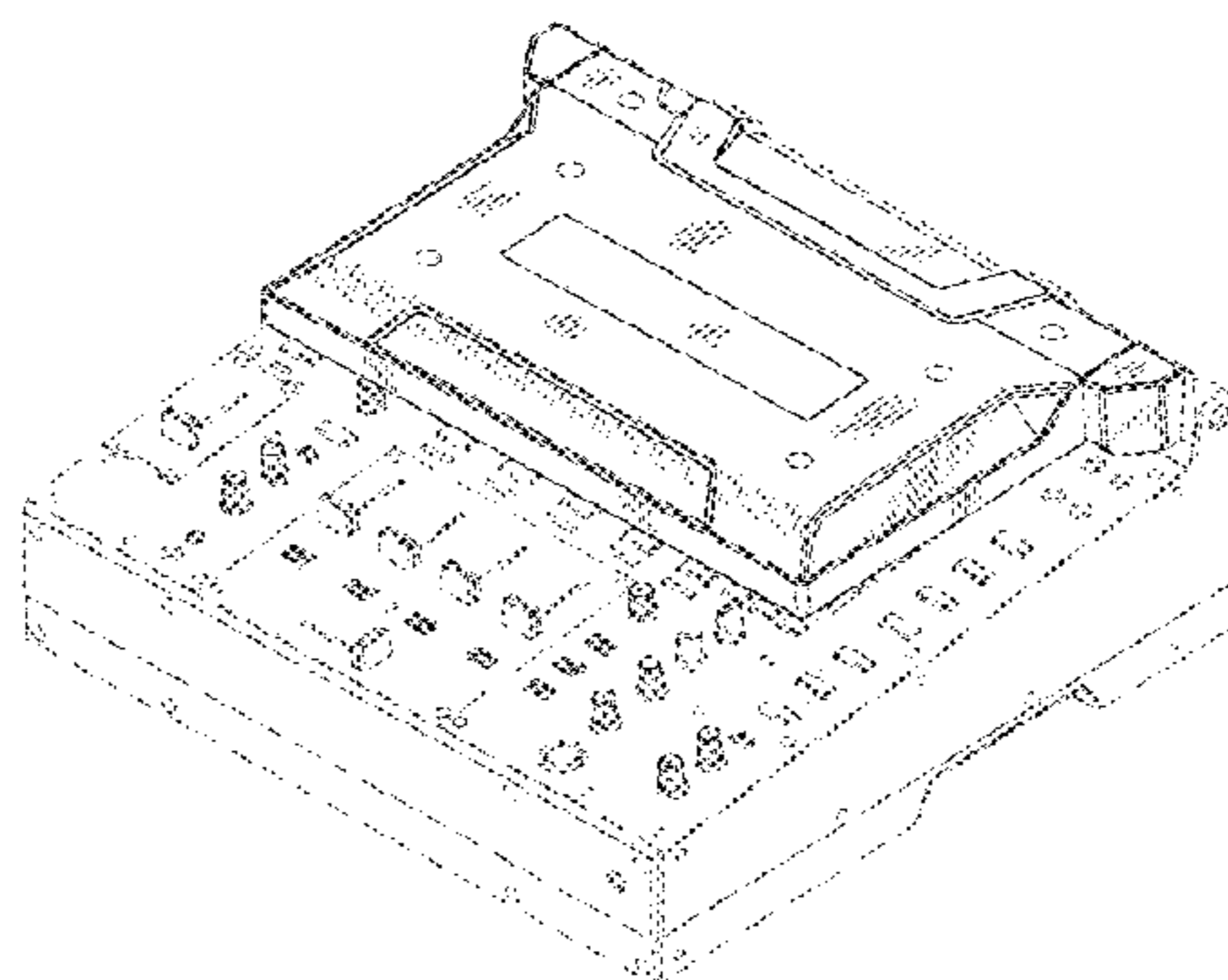
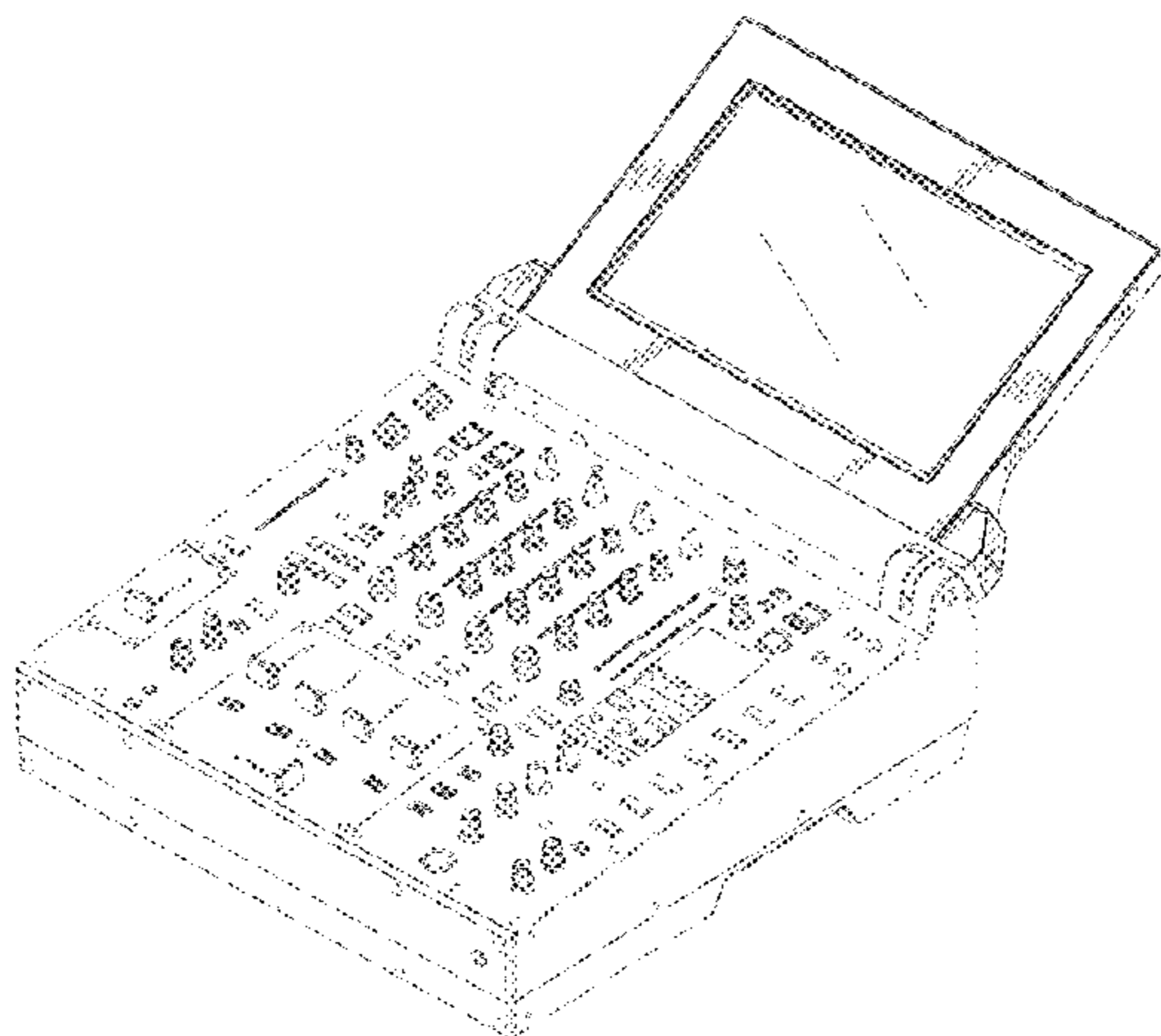

(56)

References Cited

U.S. PATENT DOCUMENTS

D771,020 S	*	11/2016	O'Donnell	D14/217
D772,200 S	*	11/2016	Tschetter	D14/217
D780,718 S	*	3/2017	Jackson	D14/217
D783,001 S	*	4/2017	Tschetter	D14/217

* cited by examiner

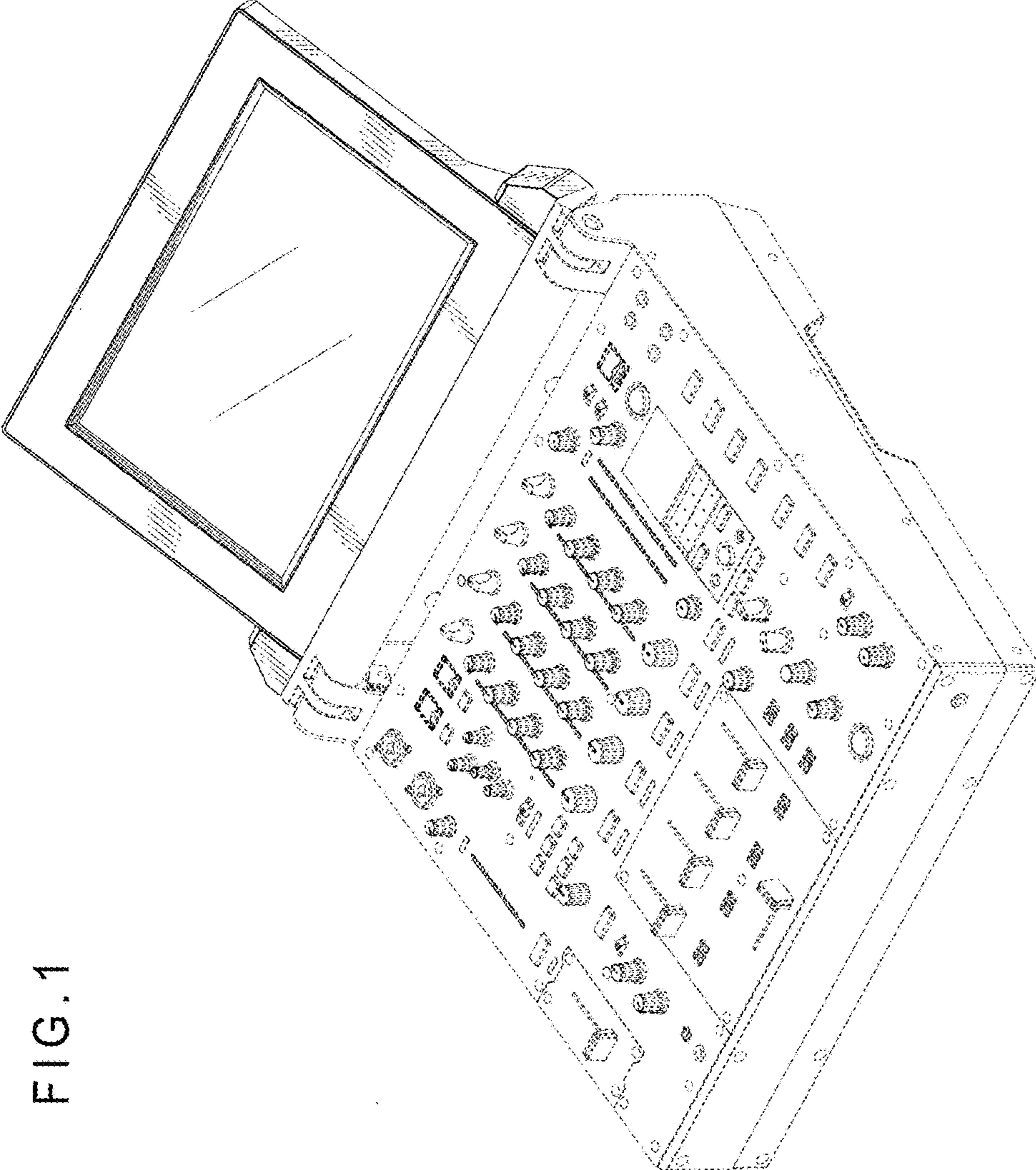

FIG. 1

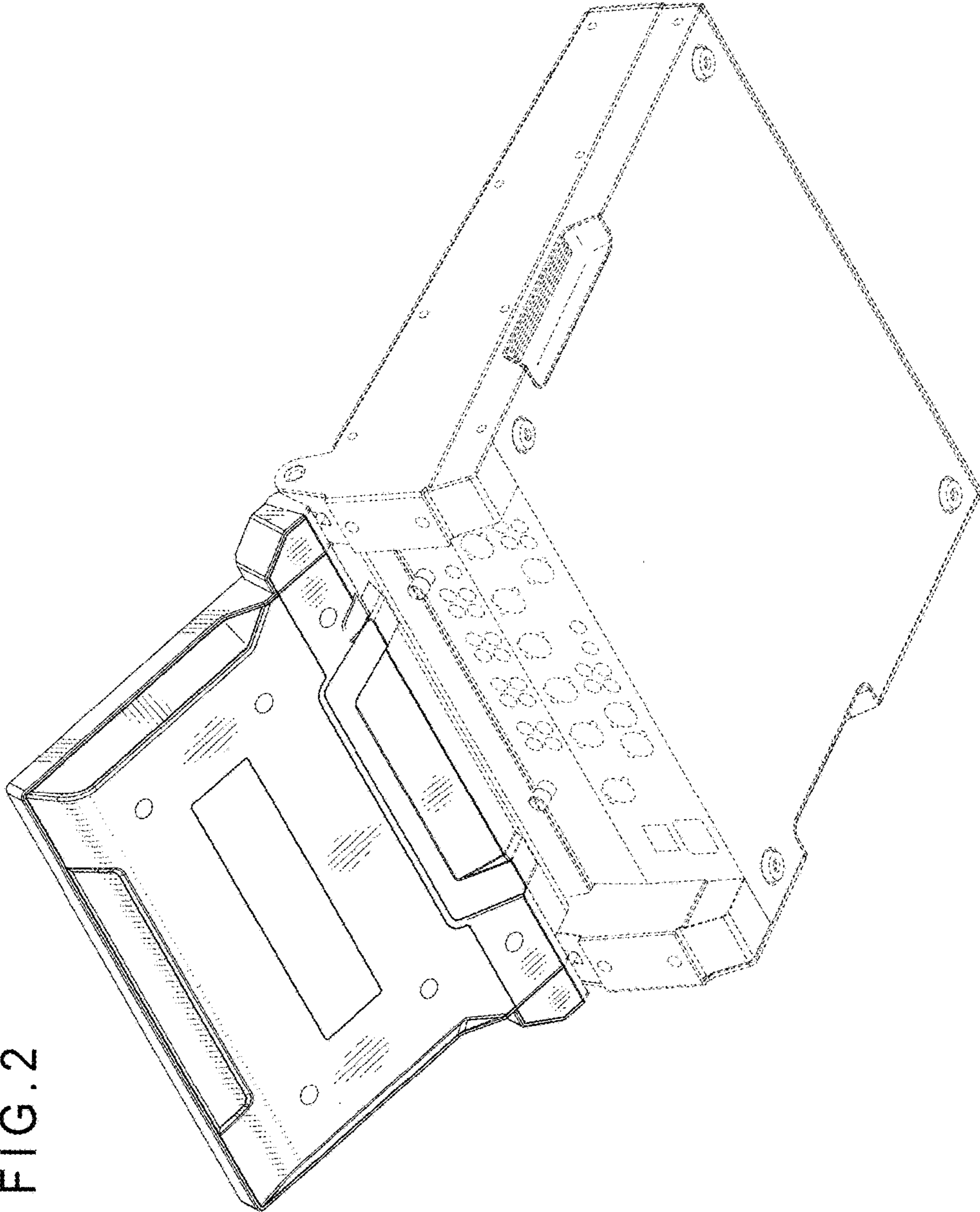

FIG. 2

FIG. 3

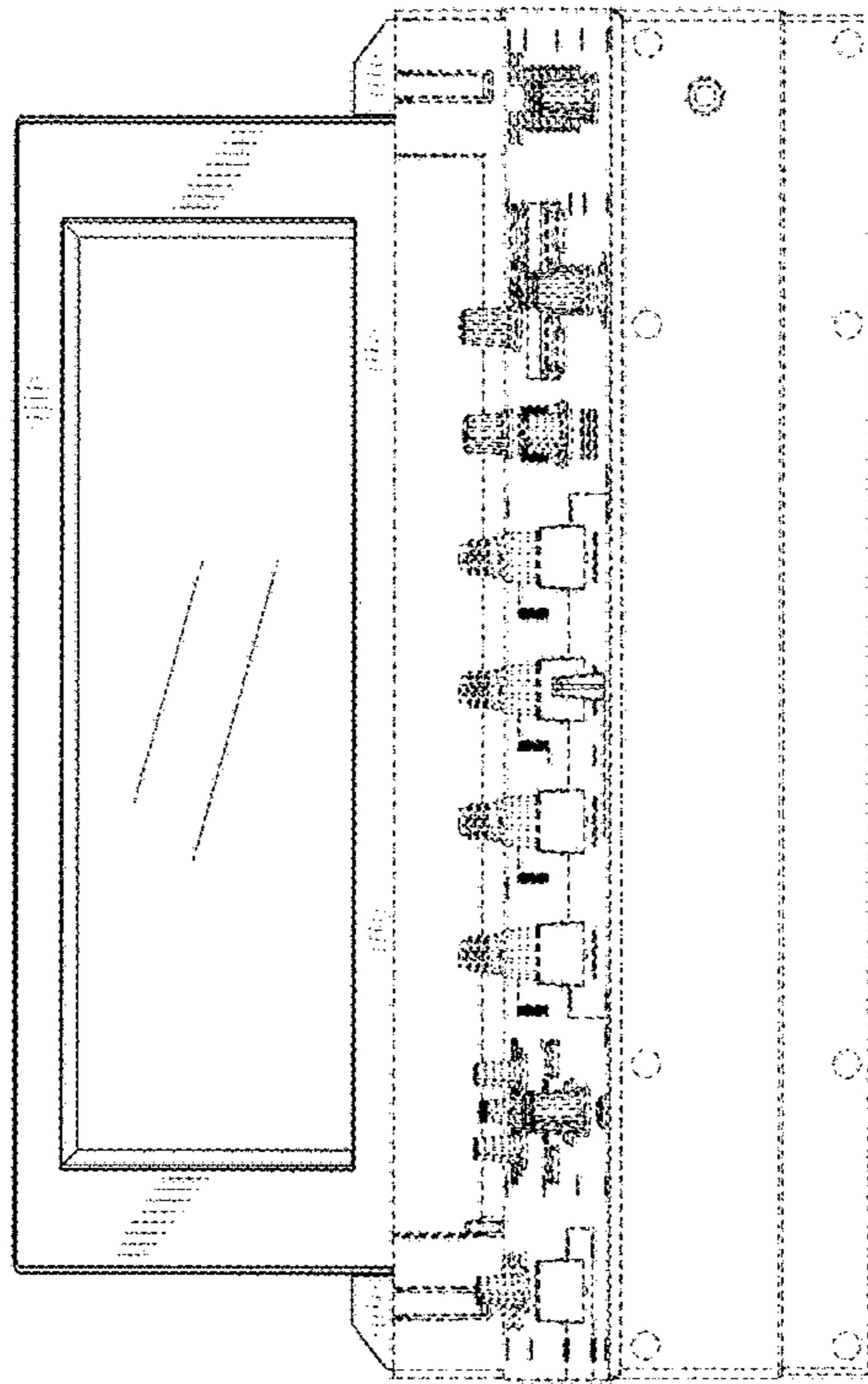

FIG. 4

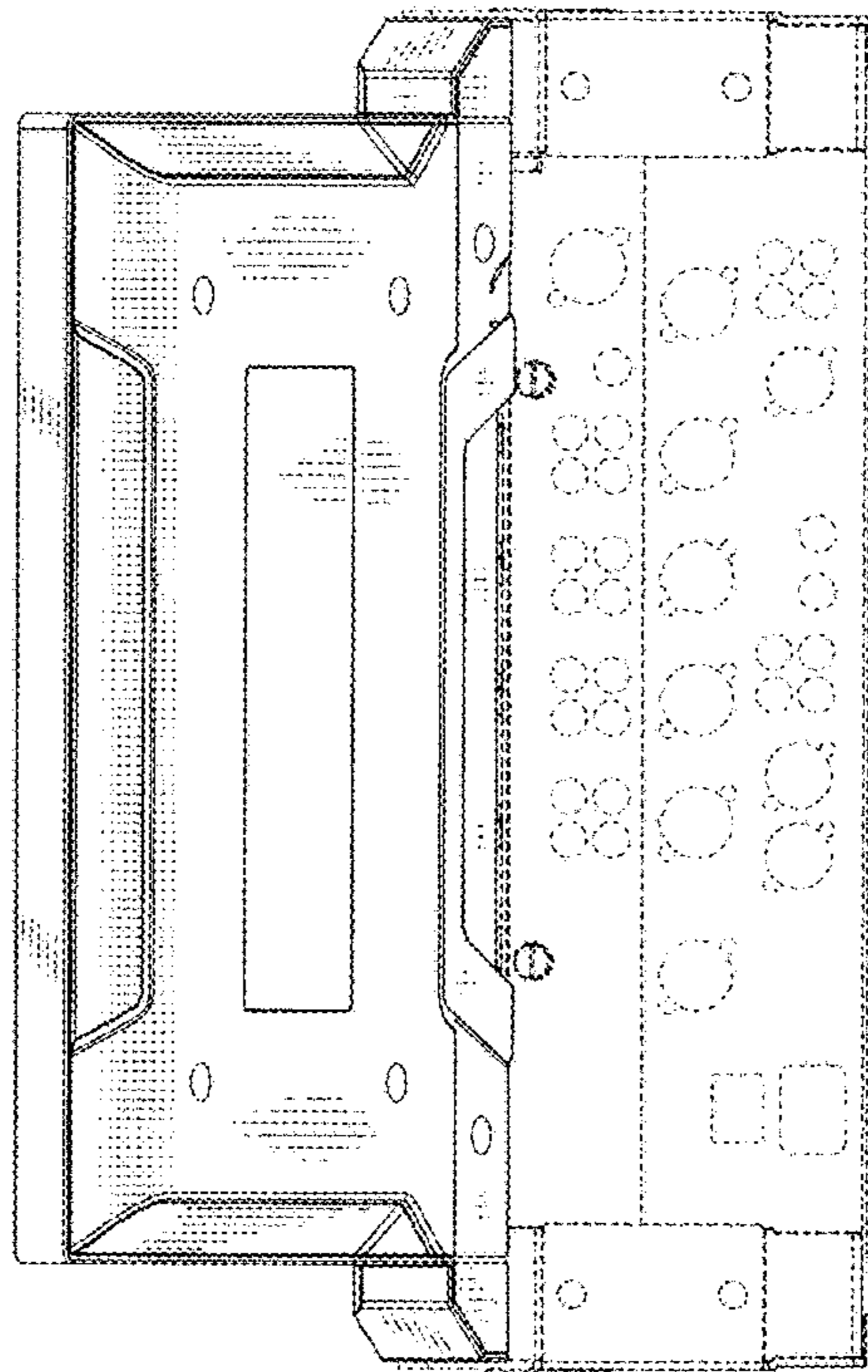

FIG. 5

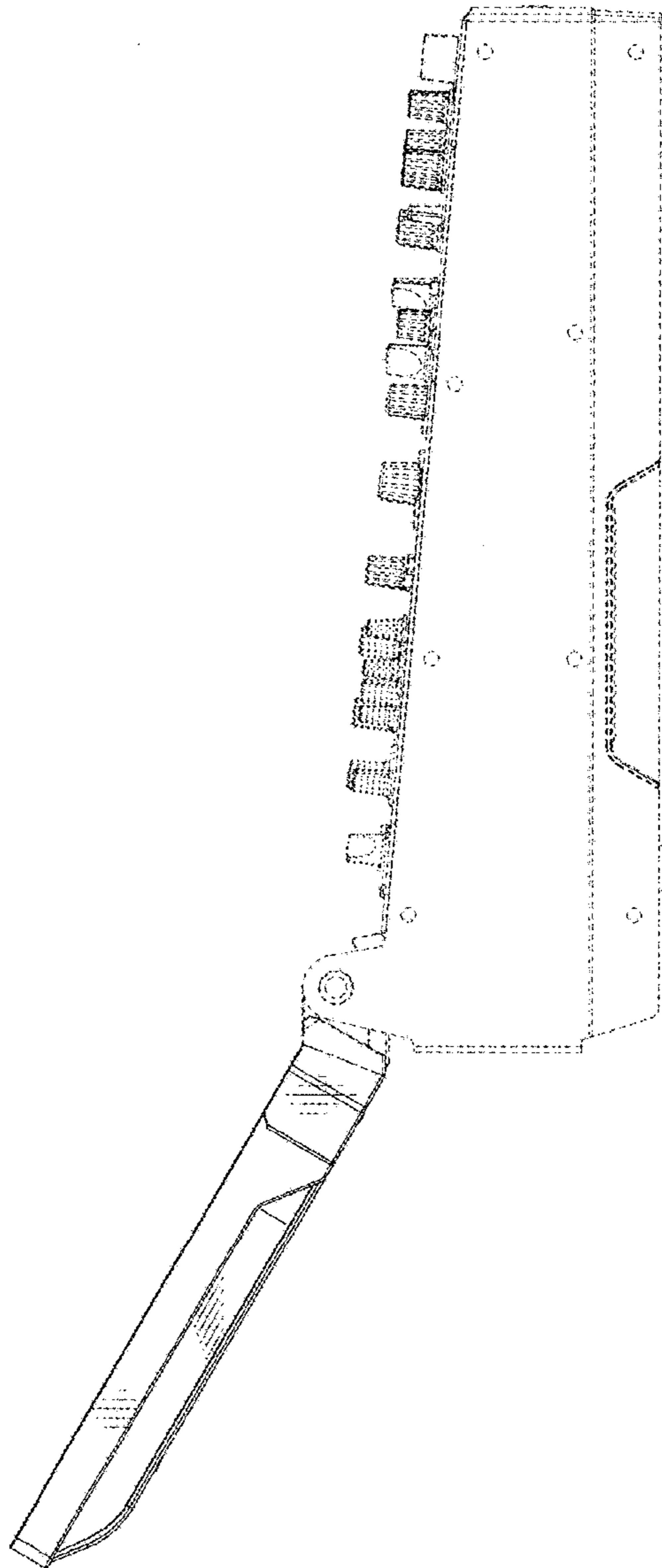
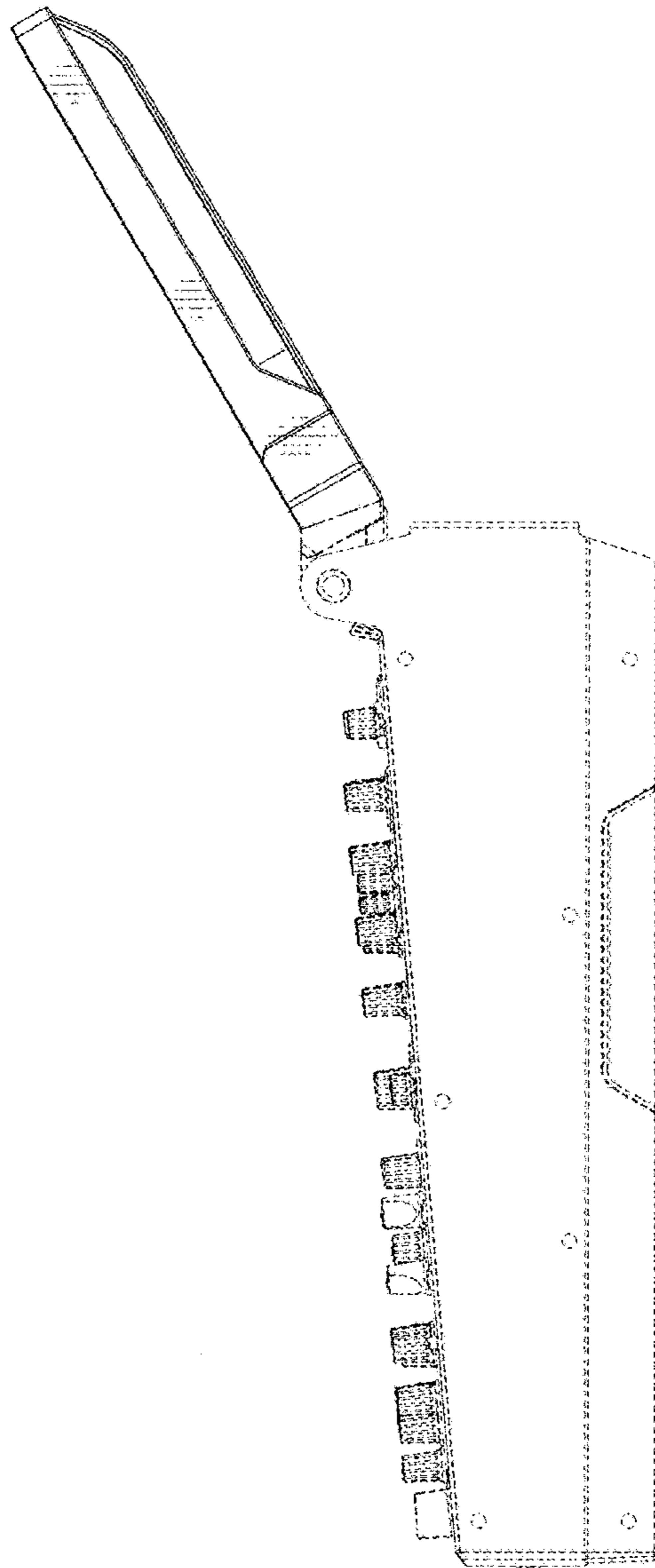

FIG. 6



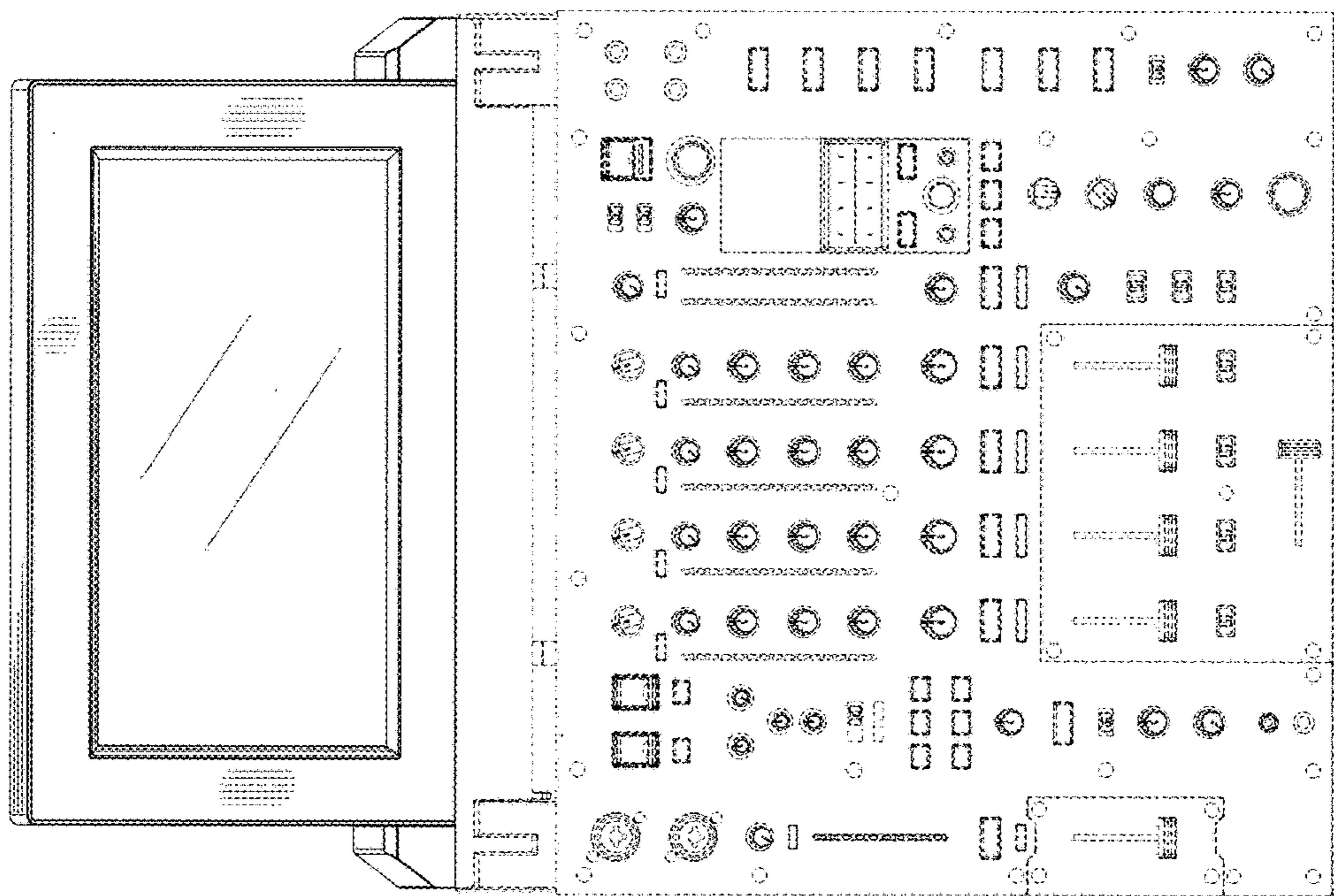

FIG. 7

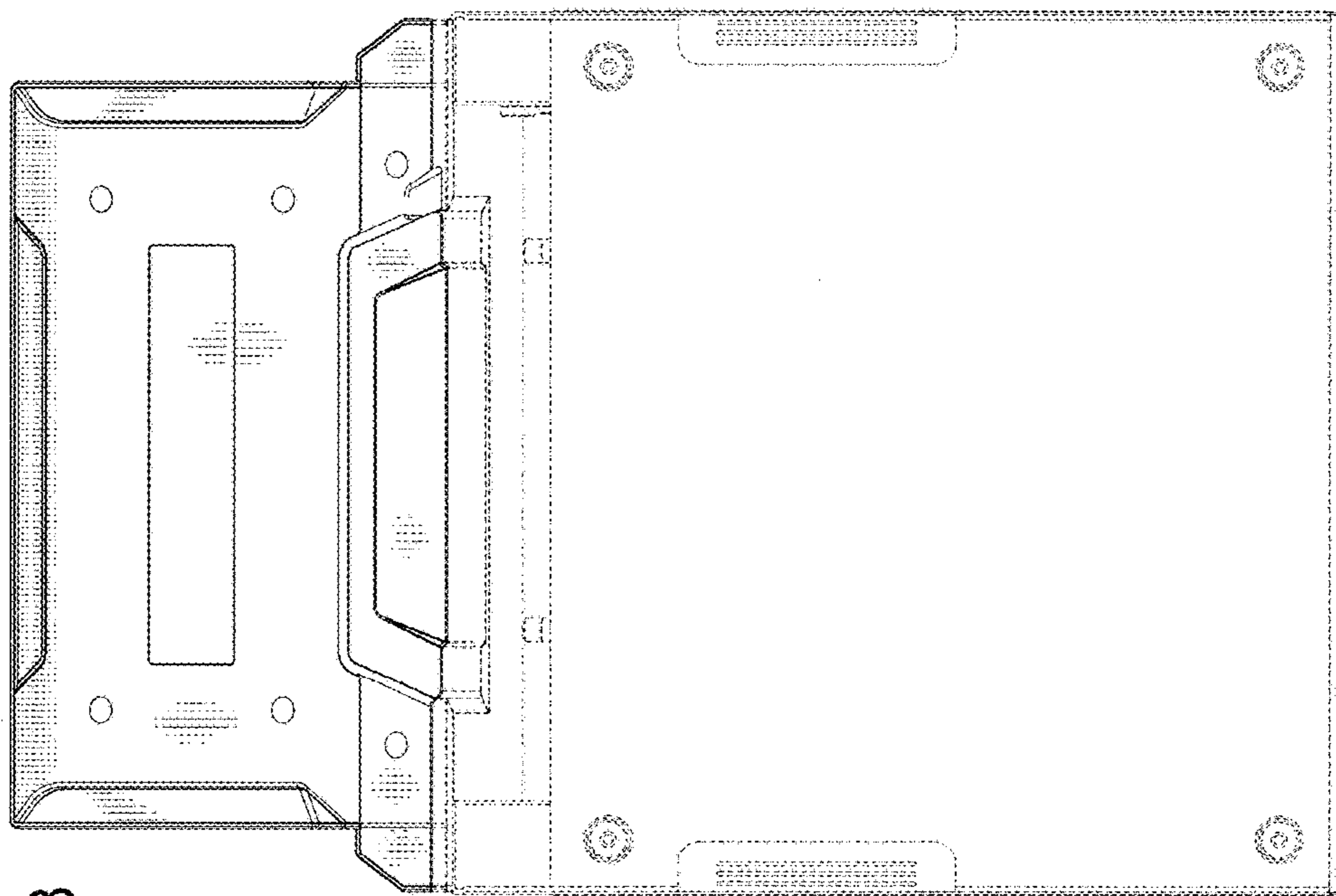

FIG. 8

FIG. 9

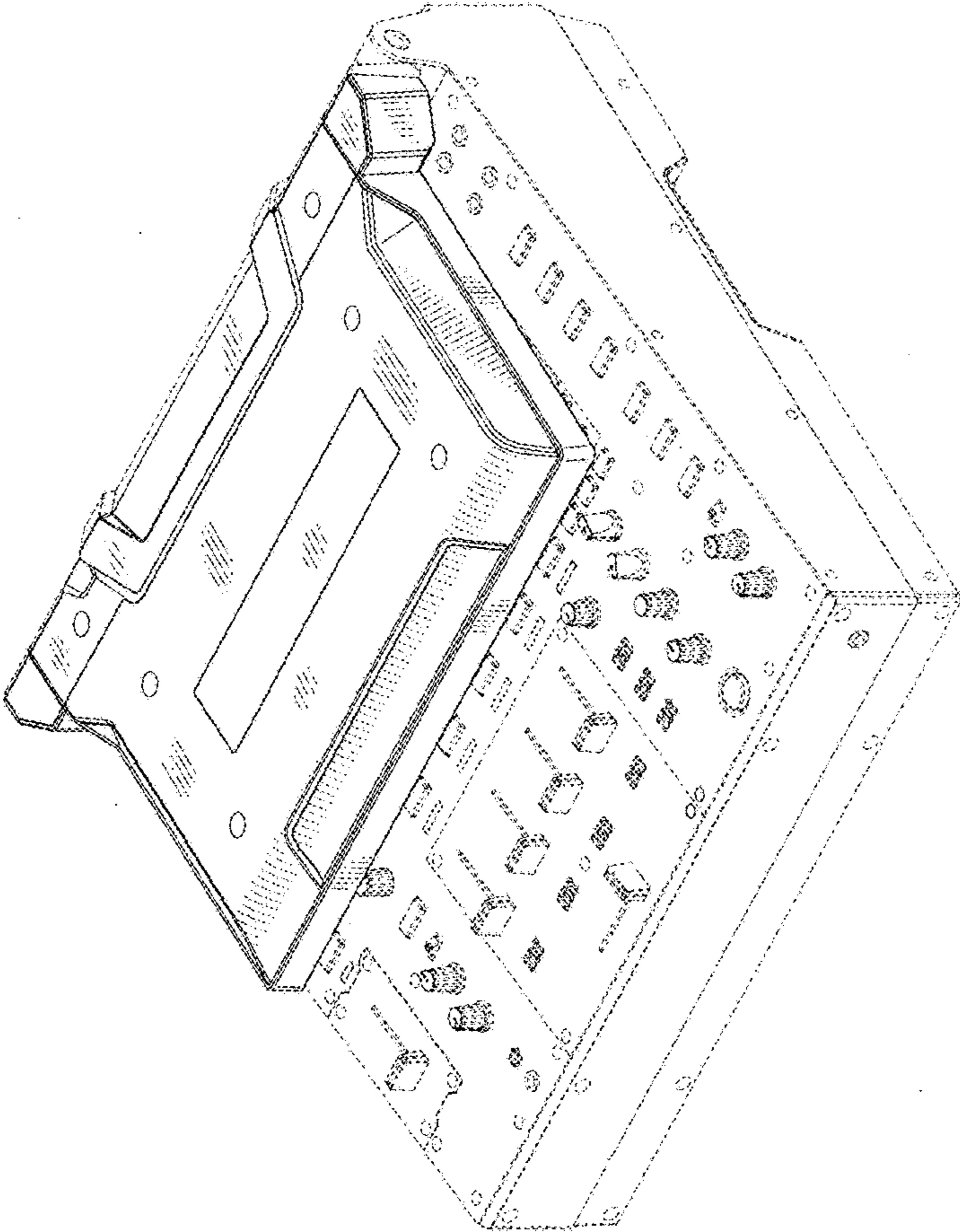

FIG. 10

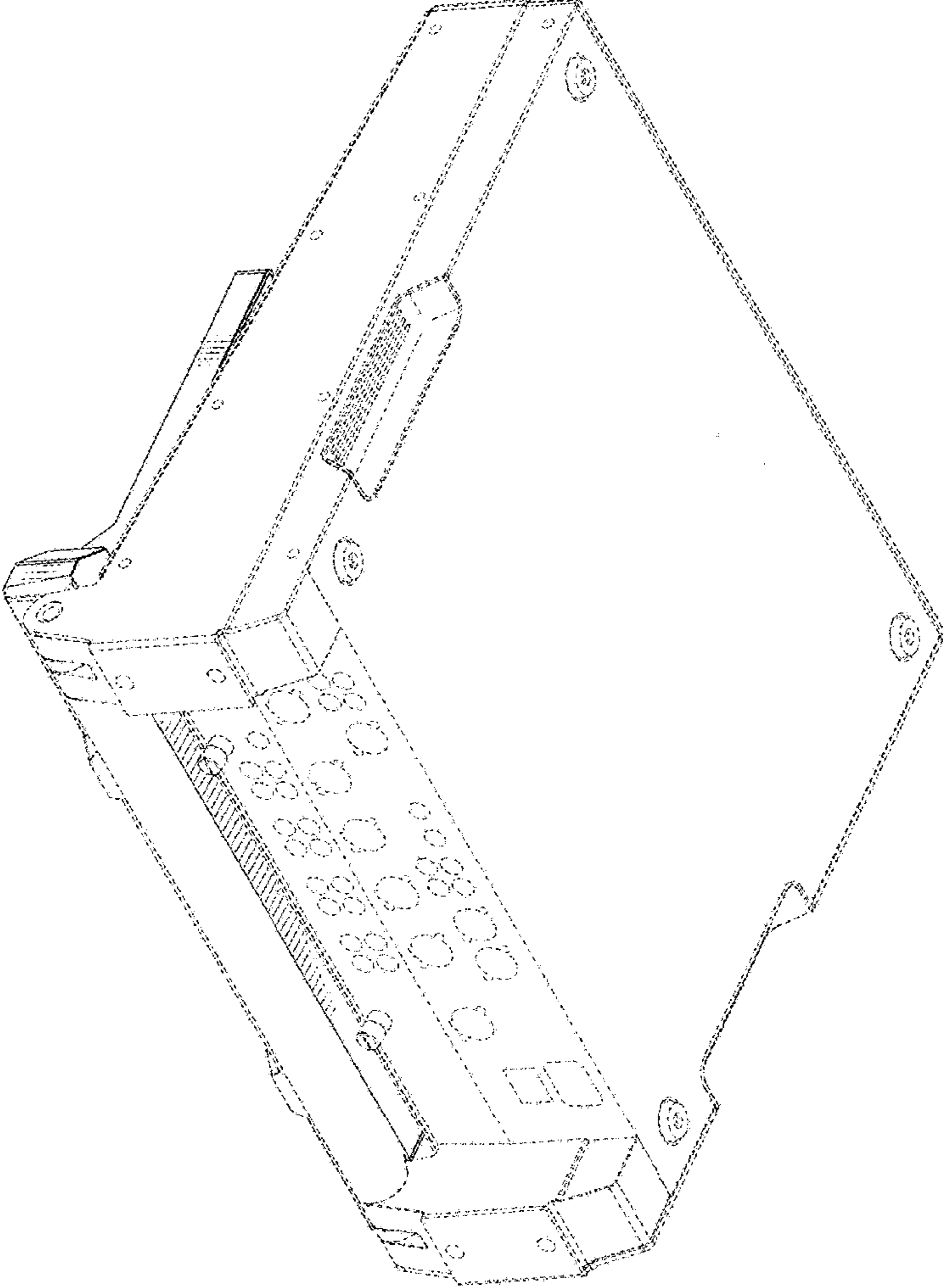

FIG. 11

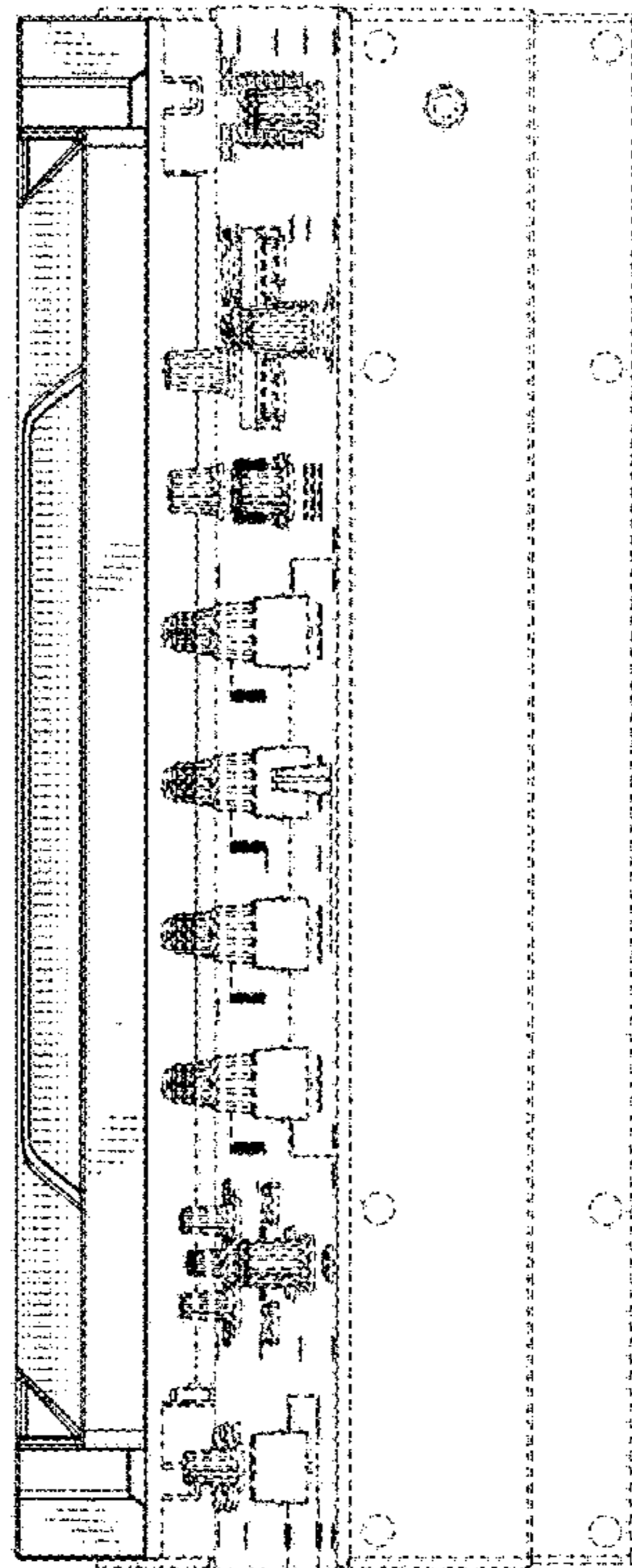

FIG. 12

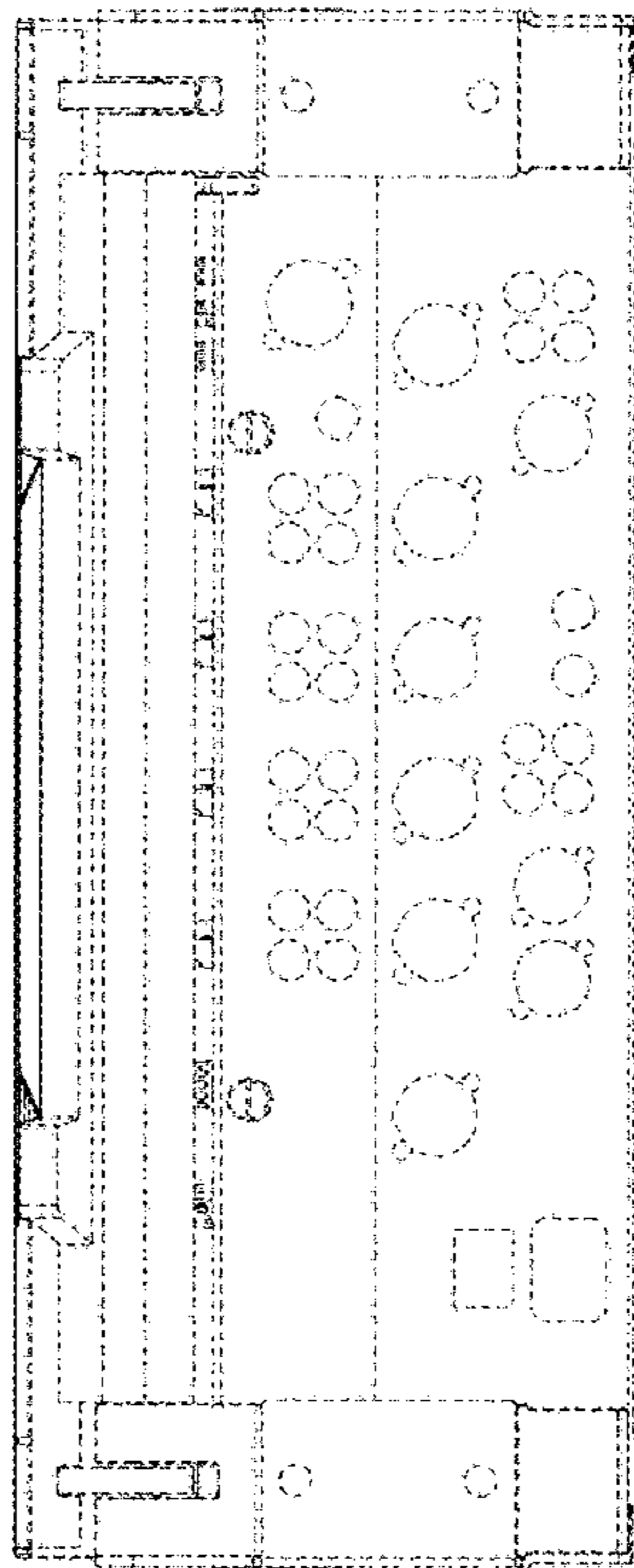

FIG. 13

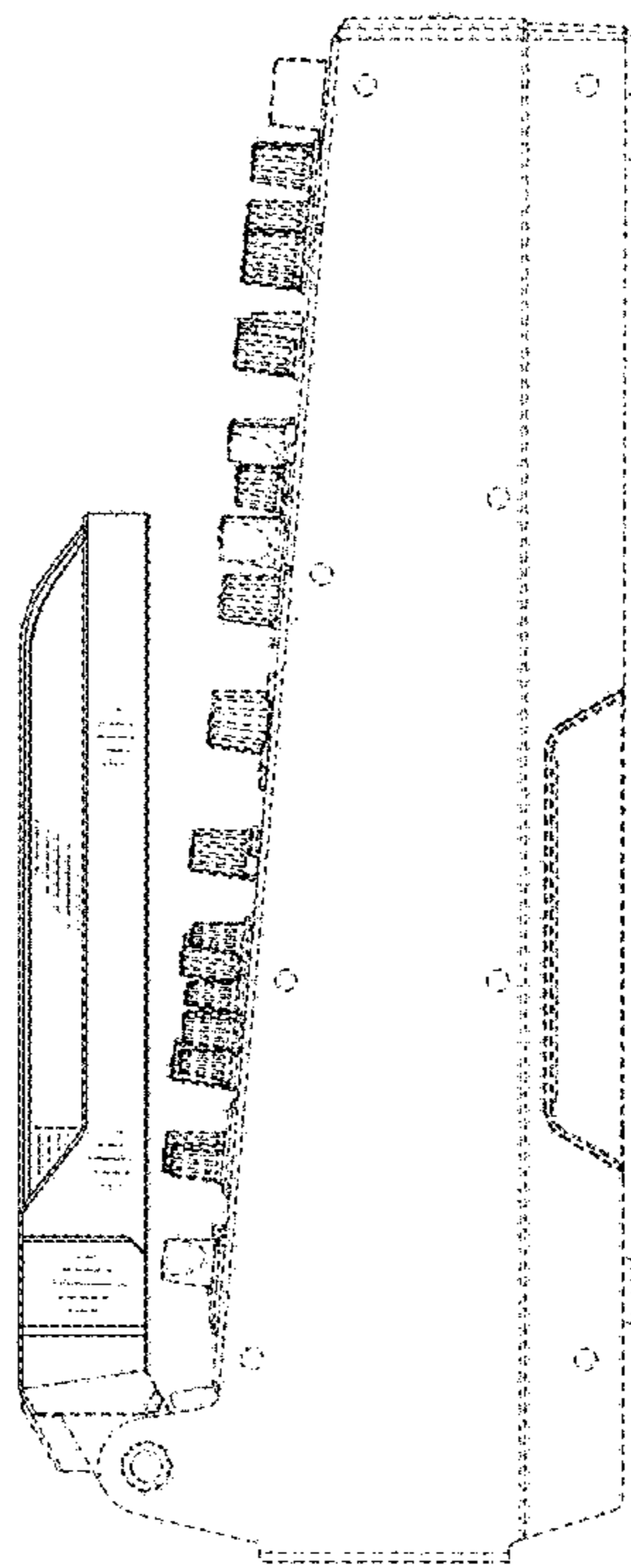

FIG. 14

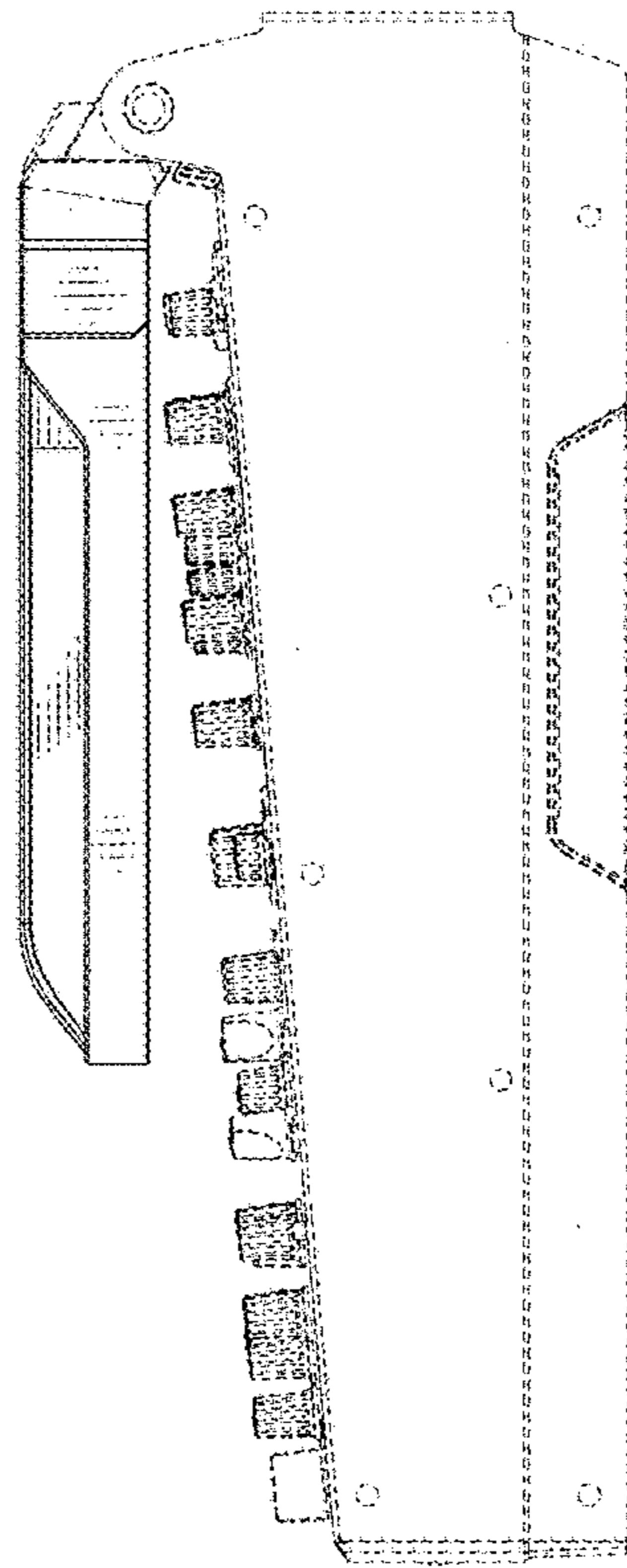

FIG. 15

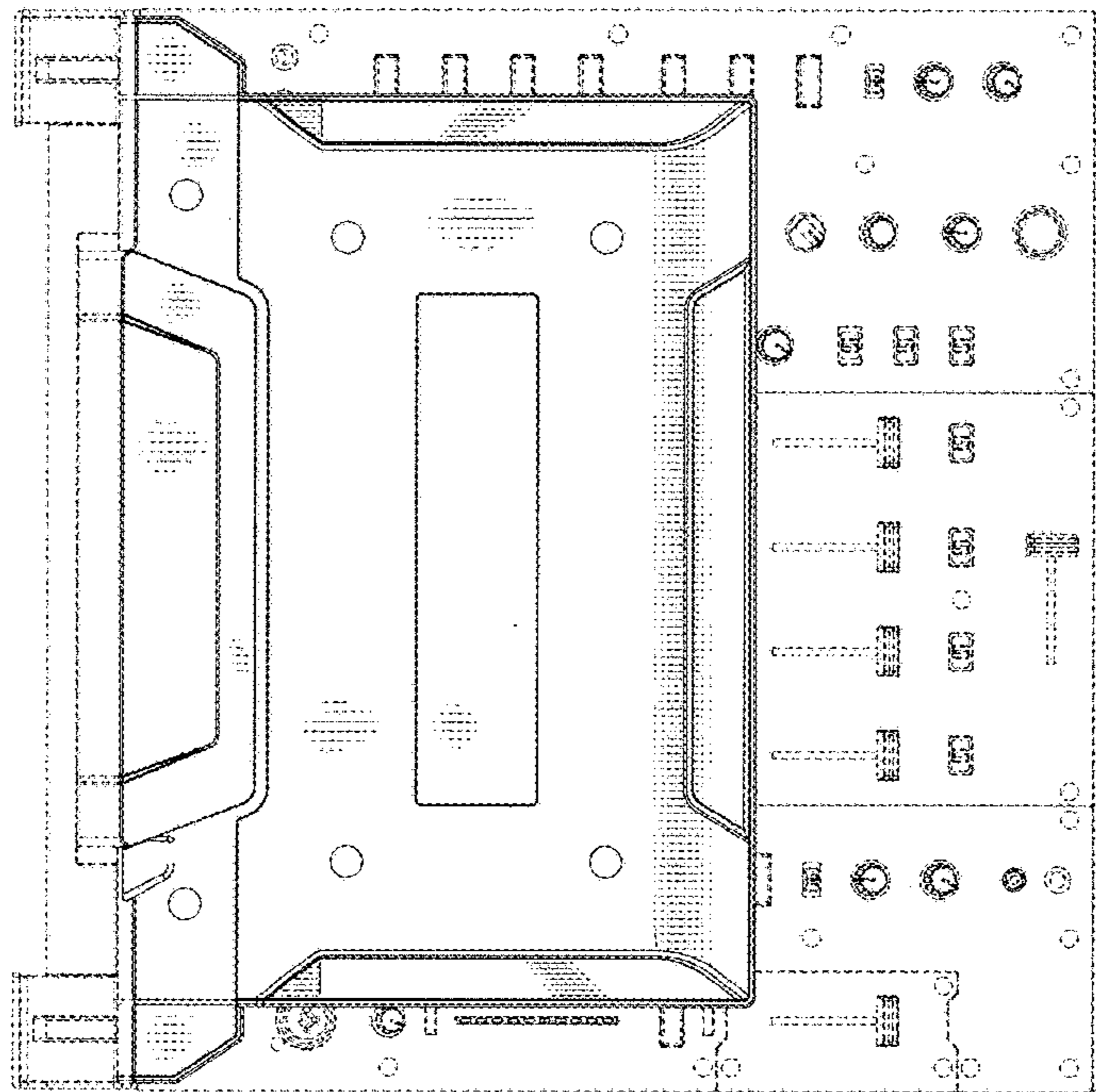

FIG. 16

