



US00D795474S

(12) **United States Design Patent** (10) **Patent No.:** **US D795,474 S**
Madden (45) **Date of Patent:** **** Aug. 22, 2017**

(54) **MOTORCYCLE REAR LIGHTING ACCESSORY**

(71) Applicant: **Ciro, LLC**, Hudson, WI (US)

(72) Inventor: **Kenneth E Madden**, Andover, MN (US)

(73) Assignee: **Ciro, LLC**, Hudson, WI (US)

(**) Term: **15 Years**

(21) Appl. No.: **29/566,788**

(22) Filed: **Jun. 2, 2016**

(51) **LOC (10) Cl.** **28-07**

(52) **U.S. Cl.**
USPC **D26/28**

(58) **Field of Classification Search**
USPC D26/28-36; 362/459-468, 475-478, 362/485-487
CPC F21S 48/00; F21S 48/10; F21S 48/115; F21S 48/225; F21S 48/1233; F21S 48/1266; F21S 48/1388; F21S 48/2268; F21V 21/04
See application file for complete search history.

(56) **References Cited**

U.S. PATENT DOCUMENTS

D499,497 S * 12/2004 Hou D26/28
D518,200 S * 3/2006 Honda D26/28

D596,767 S * 7/2009 Idei D26/28
D602,184 S * 10/2009 Wu D26/28
D616,123 S * 5/2010 Ectors D26/28
D722,398 S * 2/2015 Tewell D26/28
D749,249 S * 2/2016 Thole D26/28
D749,250 S * 2/2016 Thole D26/28
D776,838 S * 1/2017 Wu D26/28
D776,842 S * 1/2017 Liao D26/28
D776,845 S * 1/2017 Knie D26/28

* cited by examiner

Primary Examiner — Angela J Lee

(74) *Attorney, Agent, or Firm* — Dicke, Billig & Czaja, PLLC

(57) **CLAIM**

The ornamental design for a motorcycle rear lighting accessory, as shown and described.

DESCRIPTION

FIG. 1 is a perspective view of the motorcycle rear lighting accessory.
FIG. 2 is a front elevation view thereof.
FIG. 3 is a rear elevation view thereof.
FIG. 4 is a top side view thereof.
FIG. 5 is a bottom side view thereof.
FIG. 6 is a right side view thereof; and,
FIG. 7 is a left side view thereof.

The front surface portions and rear surface portions shown in broken lines form no part of the claimed design.

1 Claim, 7 Drawing Sheets

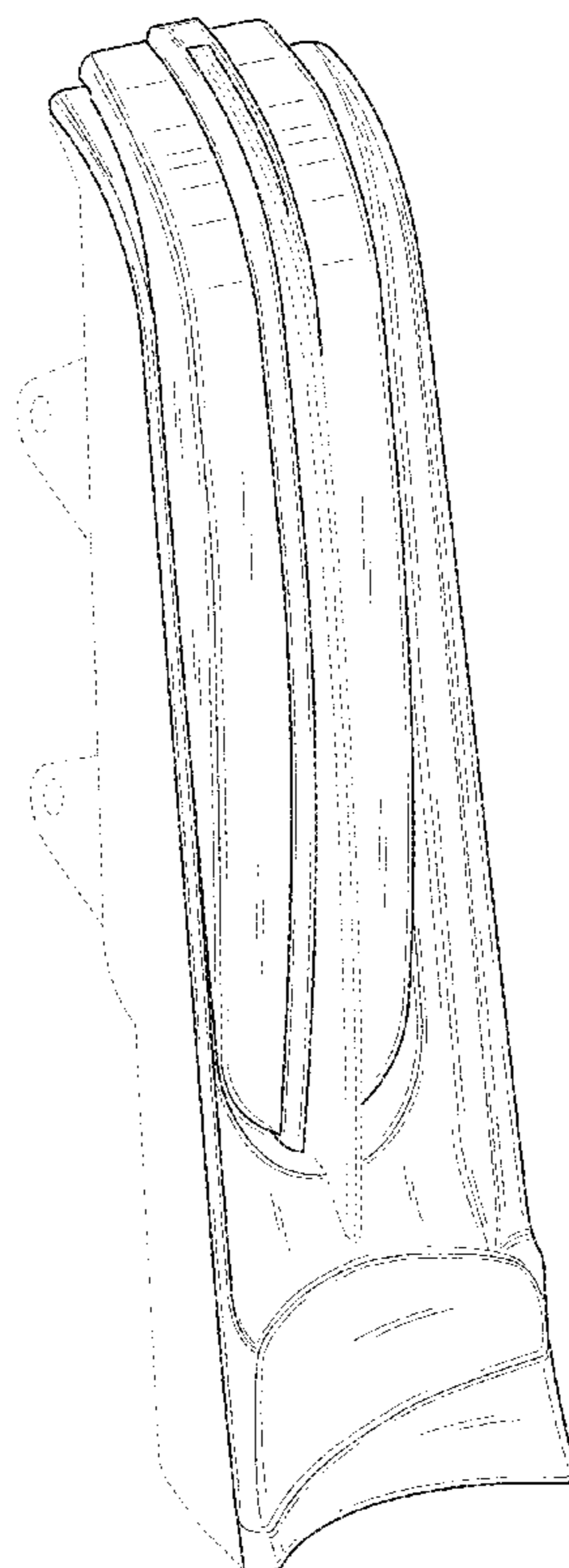

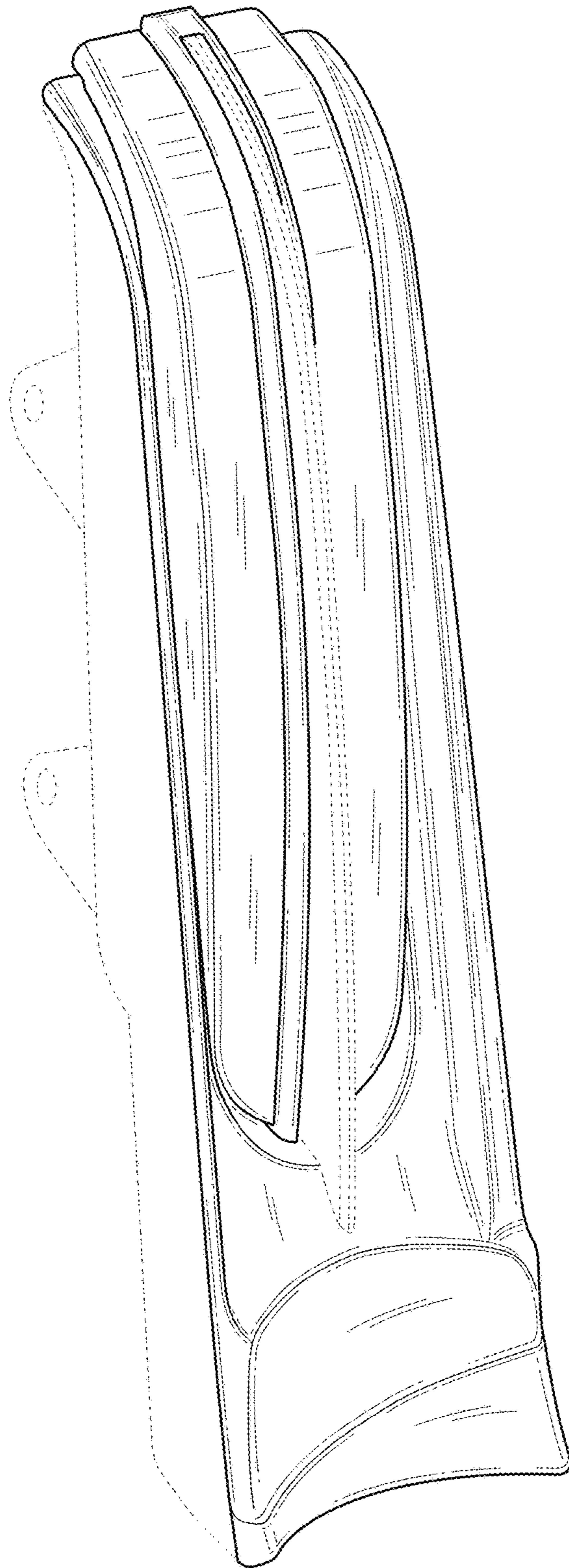

Fig. 1

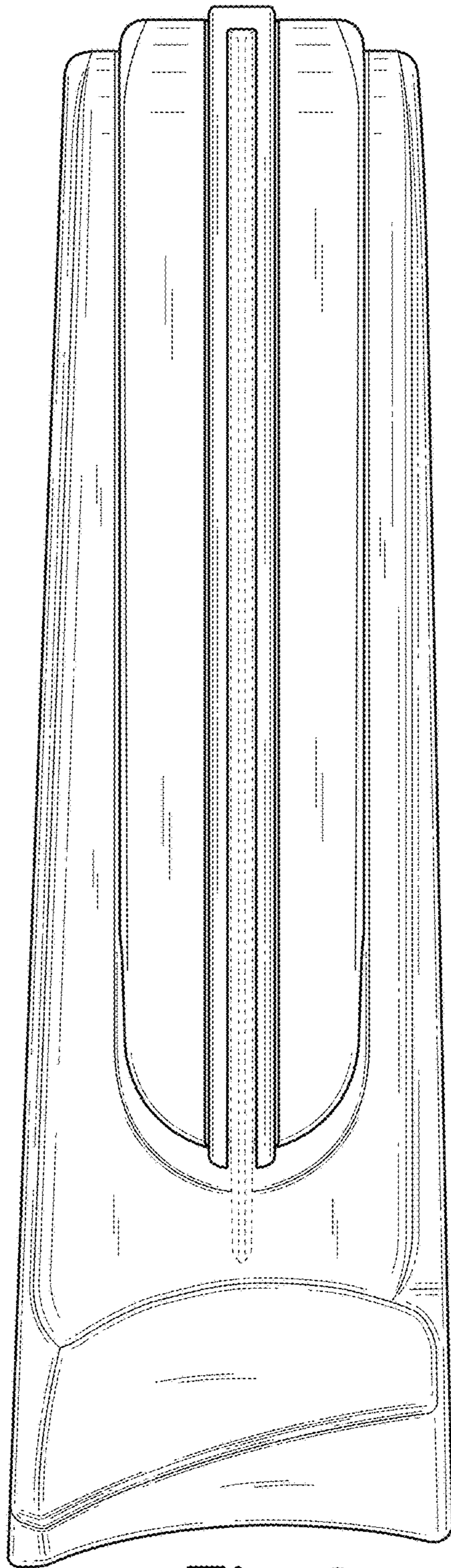

Fig. 2

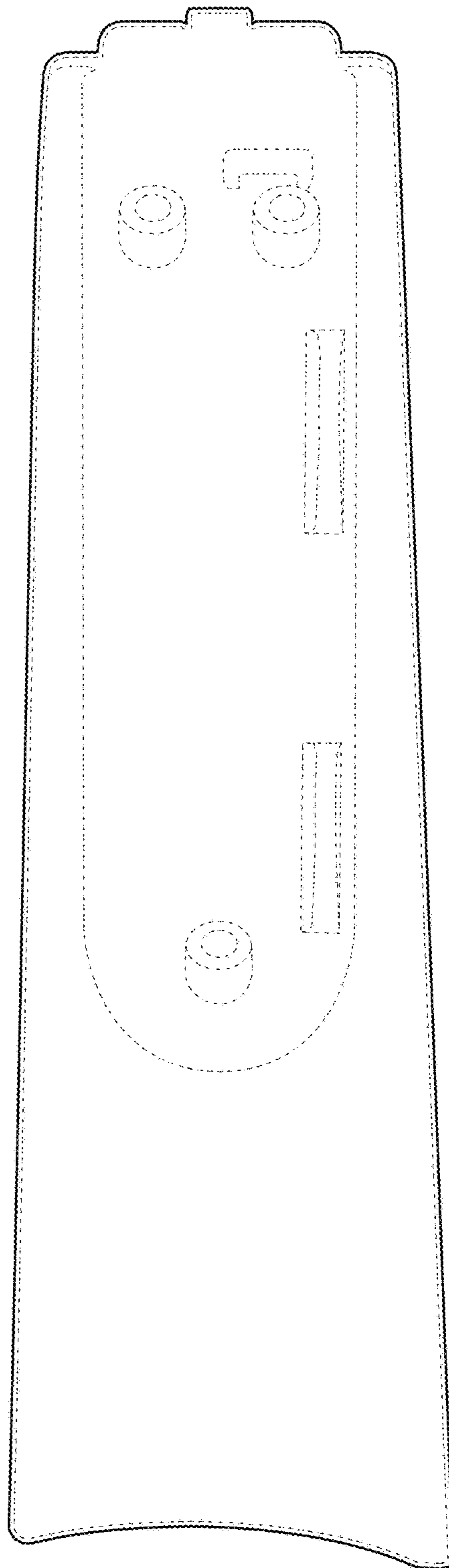

Fig. 3

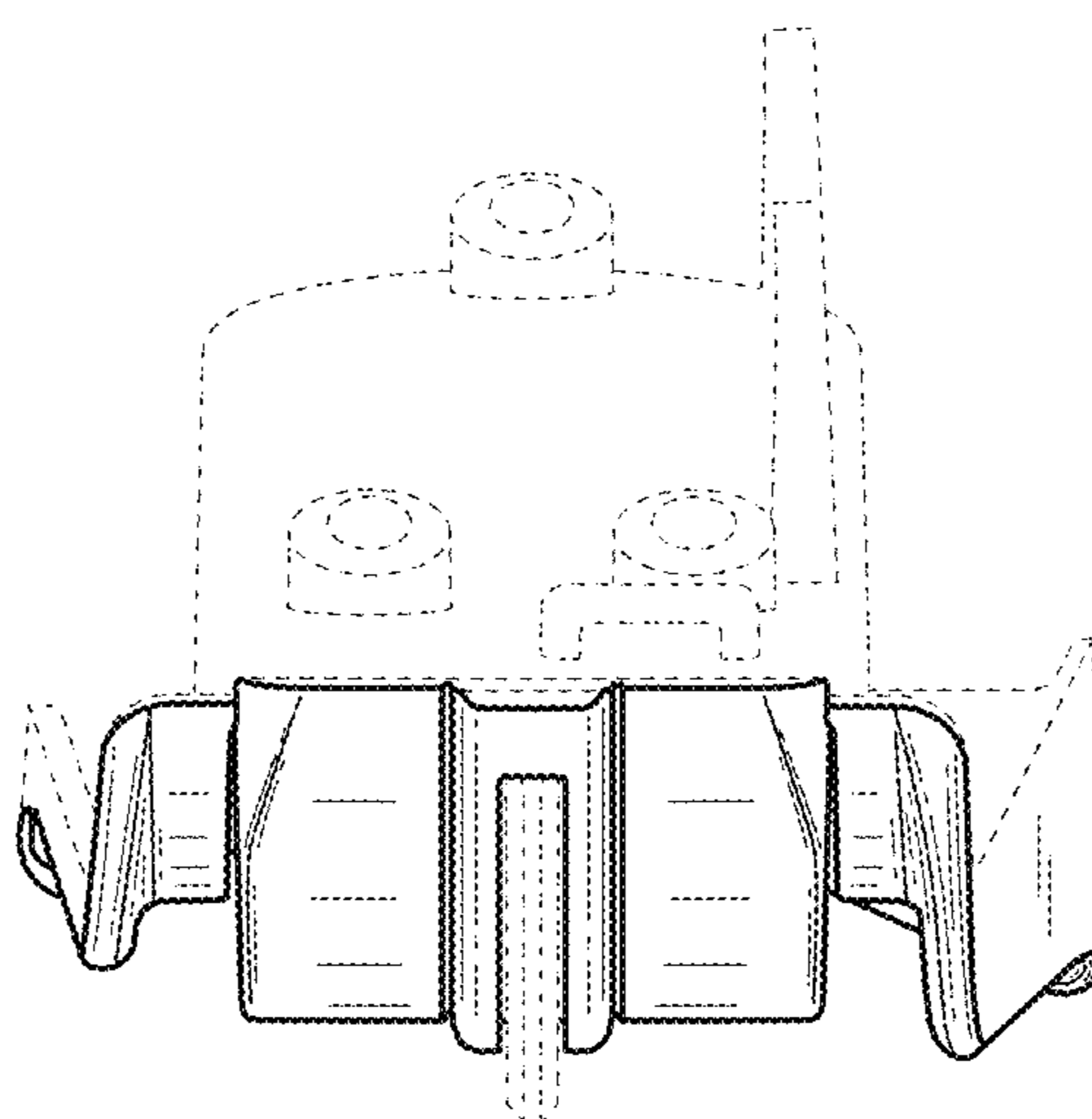

Fig. 4

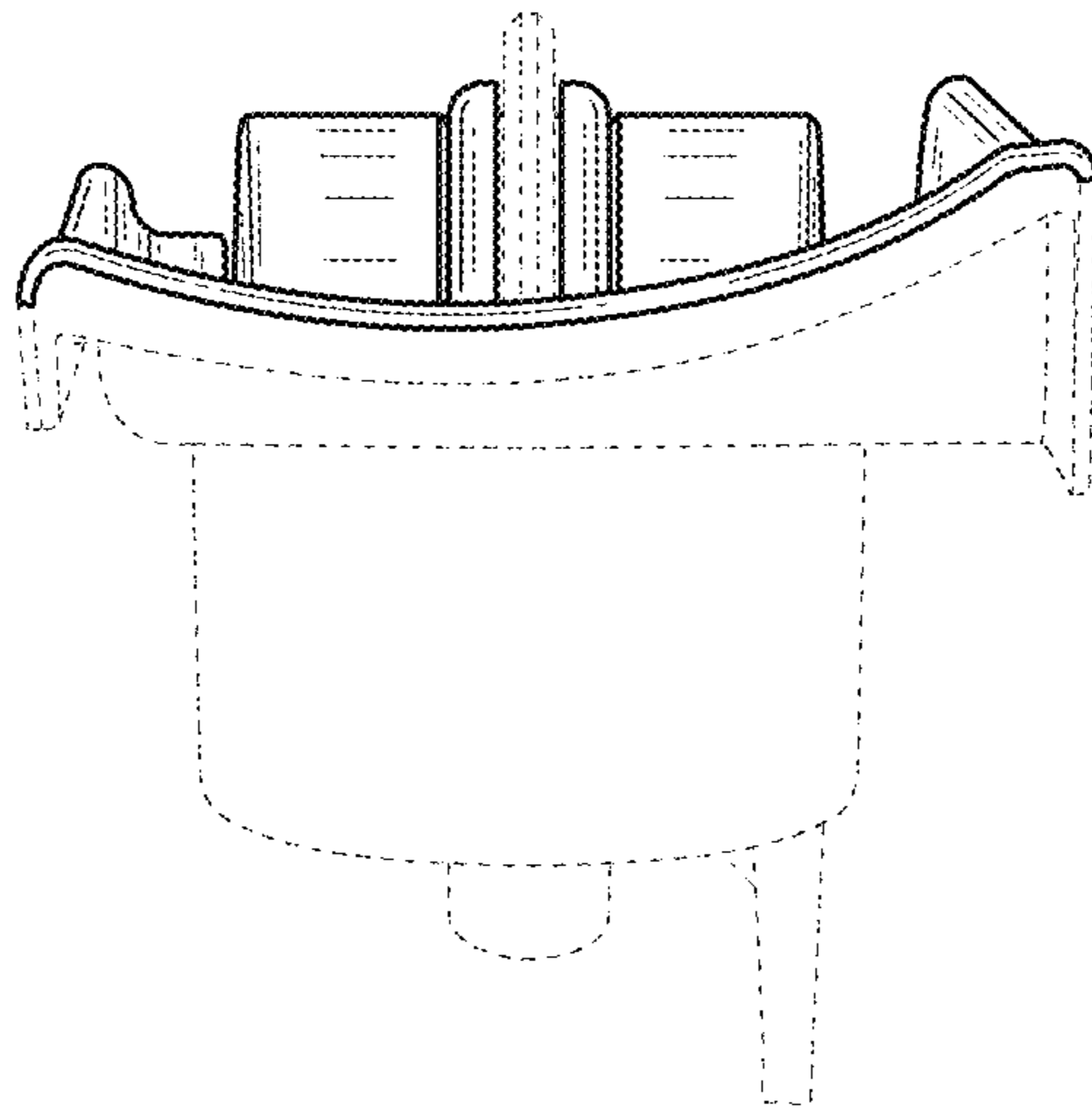

Fig. 5

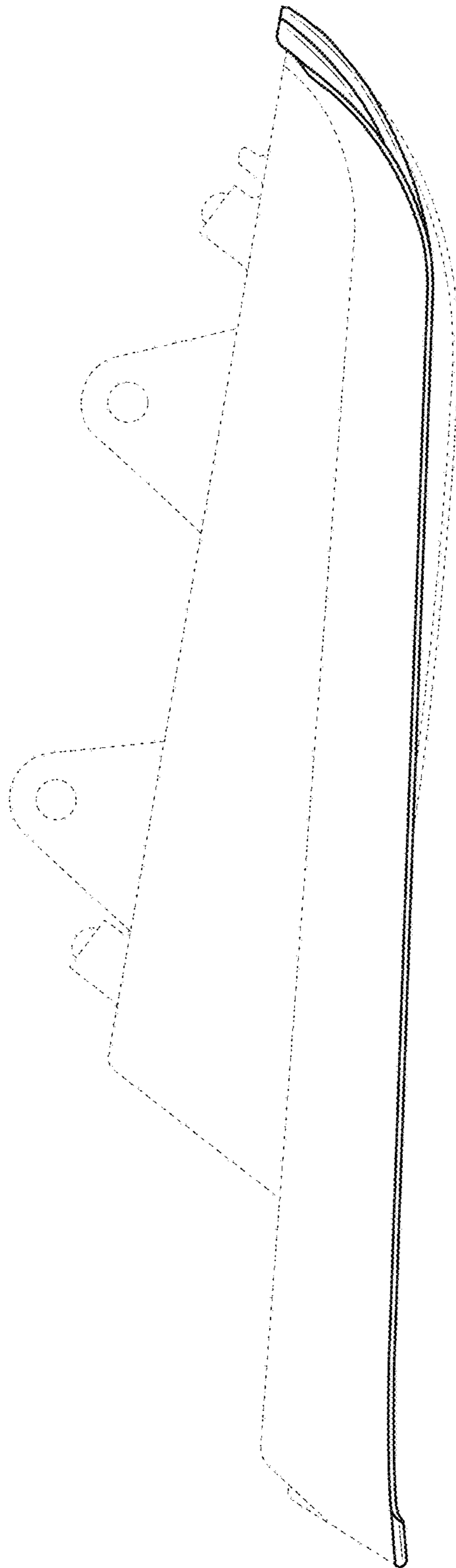

Fig. 6

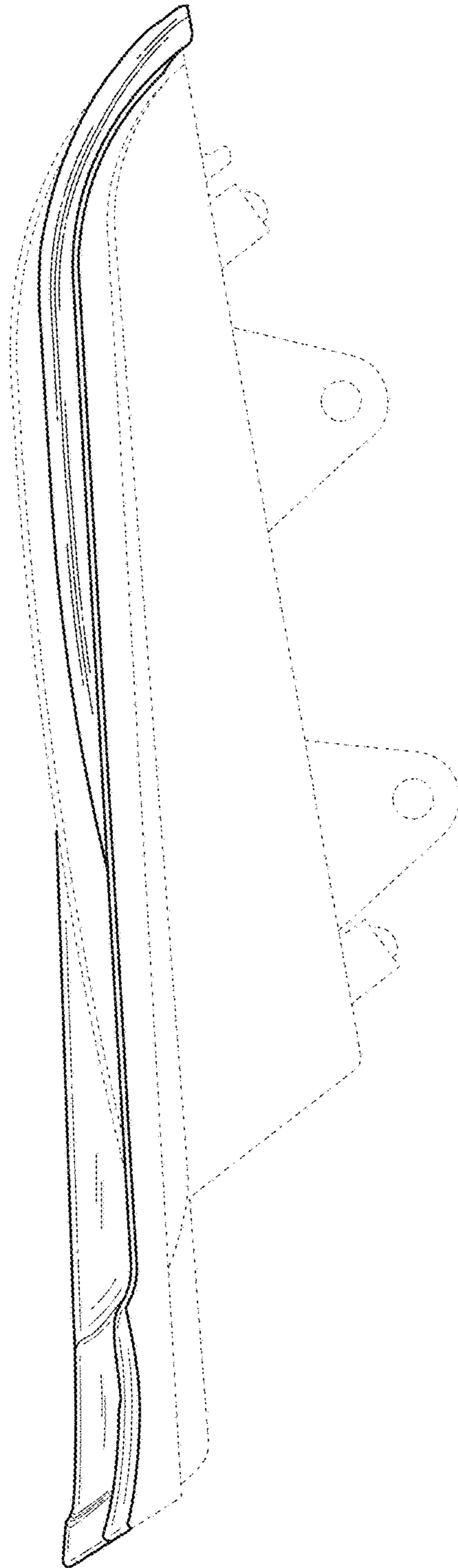

Fig. 7