



US00D795356S

(12) **United States Design Patent**
Talios et al.

(10) **Patent No.:** **US D795,356 S**

(45) **Date of Patent:** **** Aug. 22, 2017**

(54) **CARRIAGE COACH**

(71) Applicant: **Dynacraft BSC, Inc.**, American Canyon, CA (US)

(72) Inventors: **Bill Talios**, Petaluma, CA (US); **John Bisges**, Buford, GA (US); **David Castrucci**, Napa, CA (US)

(73) Assignee: **DYNACRAFT BSC, INC.**, American Canyon, CA (US)

(**) Term: **15 Years**

(21) Appl. No.: **29/547,726**

(22) Filed: **Dec. 7, 2015**

(51) **LOC (10) Cl.** **21-01**

(52) **U.S. Cl.**

USPC **D21/427; D21/535**

(58) **Field of Classification Search**

USPC D21/425, 427, 506, 510, 533, 535, 548, 280/827; 446/431

CPC .. A63G 19/00; A63H 5/00; B62B 7/00; B62B 7/006; B62B 7/008; B62B 7/04; B62B 7/12

See application file for complete search history.

(56) **References Cited**

U.S. PATENT DOCUMENTS

D213,680 S * 4/1969 Rogers D12/83
D218,229 S * 8/1970 Ponthieu D21/435
D225,073 S * 11/1972 Henning et al. D21/827
D237,790 S * 11/1975 Cone D12/102
D243,786 S * 3/1977 White D21/535

D283,994 S * 5/1986 Perry D12/83
D294,607 S * 3/1988 Zacherle D21/506
D351,873 S * 10/1994 Jones, Jr. D21/533
D366,634 S * 1/1996 Anderson D12/83
D471,843 S * 3/2003 Hall D12/16
D540,874 S * 4/2007 Han D19/74
D619,377 S * 7/2010 Chiu D6/310
D678,424 S * 3/2013 Blanco D21/427

* cited by examiner

Primary Examiner — Cynthia M Chin

(74) *Attorney, Agent, or Firm* — Michael Best & Friedrich LLP

(57) **CLAIM**

We claim the ornamental design for a carriage coach, as shown and described.

DESCRIPTION

FIG. 1 is a perspective view of a carriage coach embodying the invention.

FIG. 2 is a right side elevation view of a carriage coach shown in FIG. 1.

FIG. 3 is a left side elevation view of a carriage coach shown in FIG. 1.

FIG. 4 is a front elevation view of a carriage coach shown in FIG. 1.

FIG. 5 is a rear elevation view of a carriage coach shown in FIG. 1.

FIG. 6 is a top plan view of a carriage coach shown in FIG. 1; and,

FIG. 7 is a bottom plan view of a carriage coach shown in FIG. 1.

The broken lines showing the environment form no part of the claimed design.

1 Claim, 7 Drawing Sheets

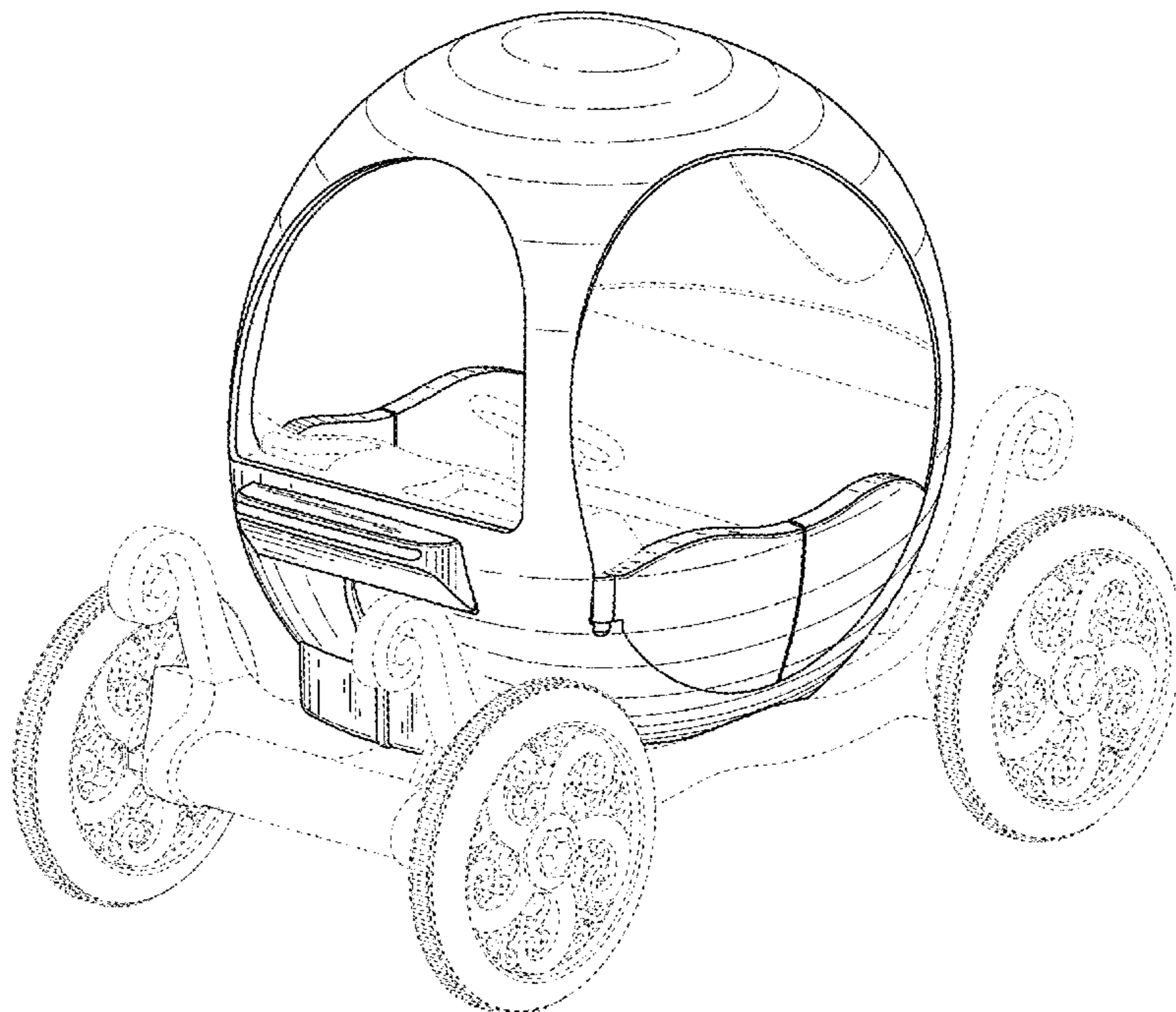

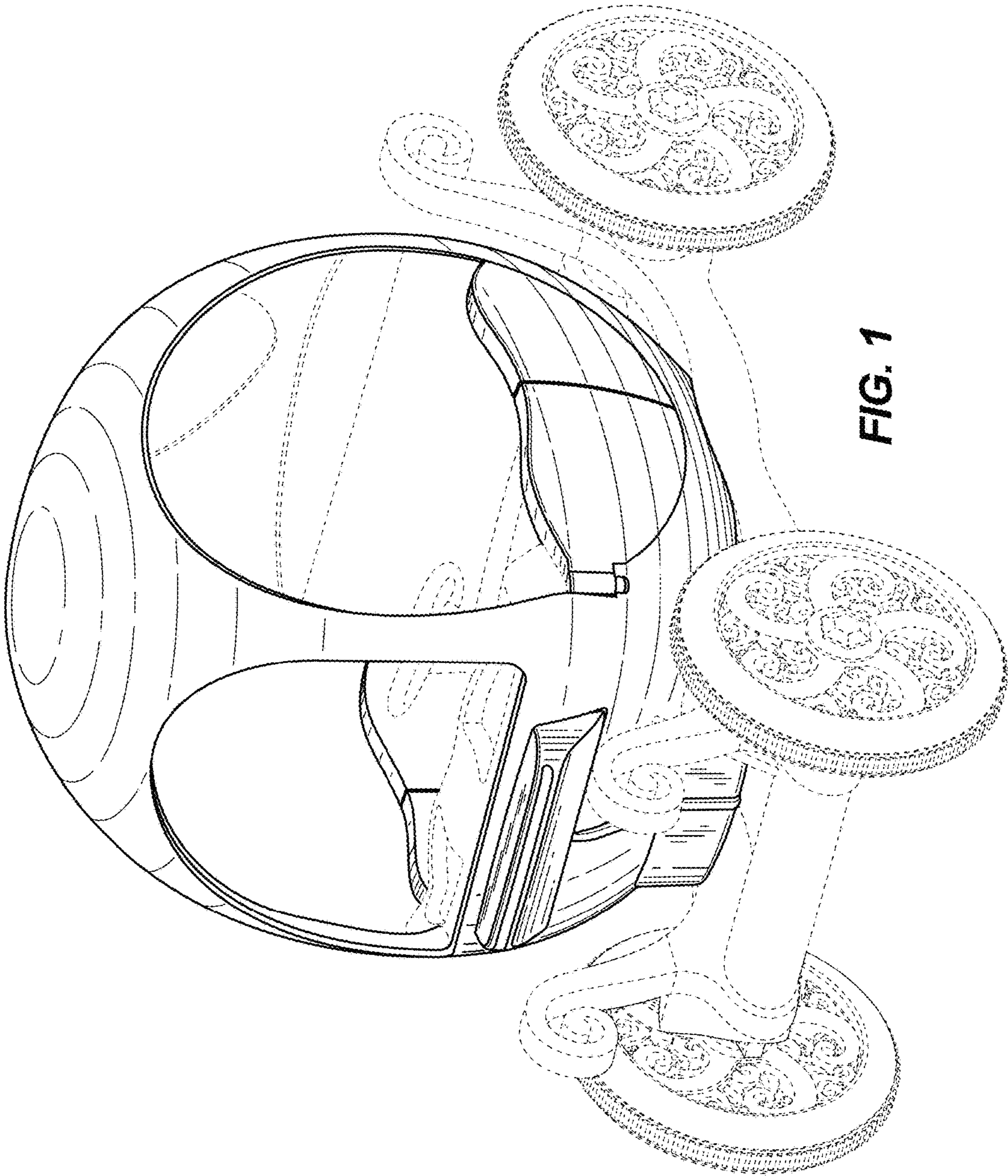

FIG. 1

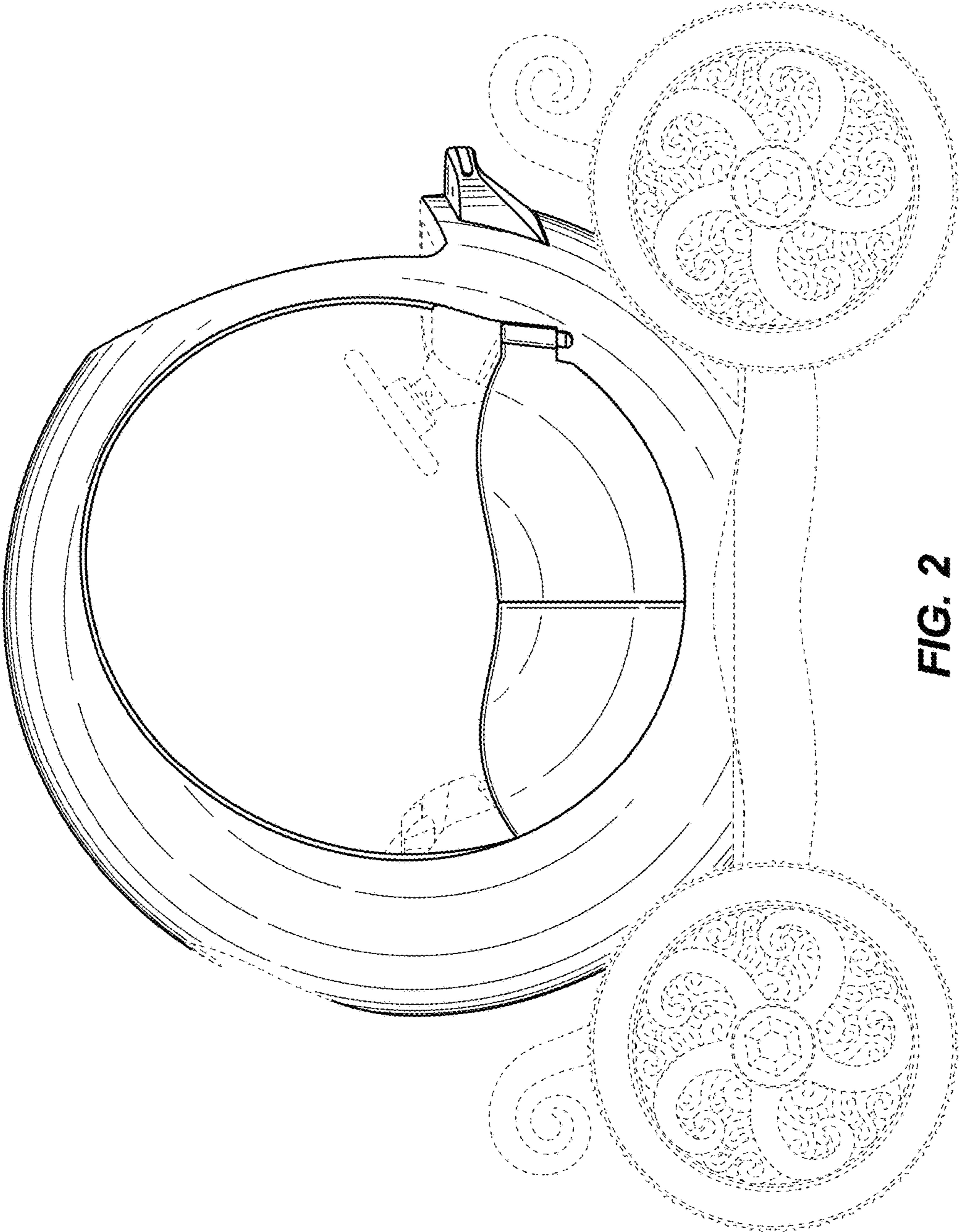

FIG. 2

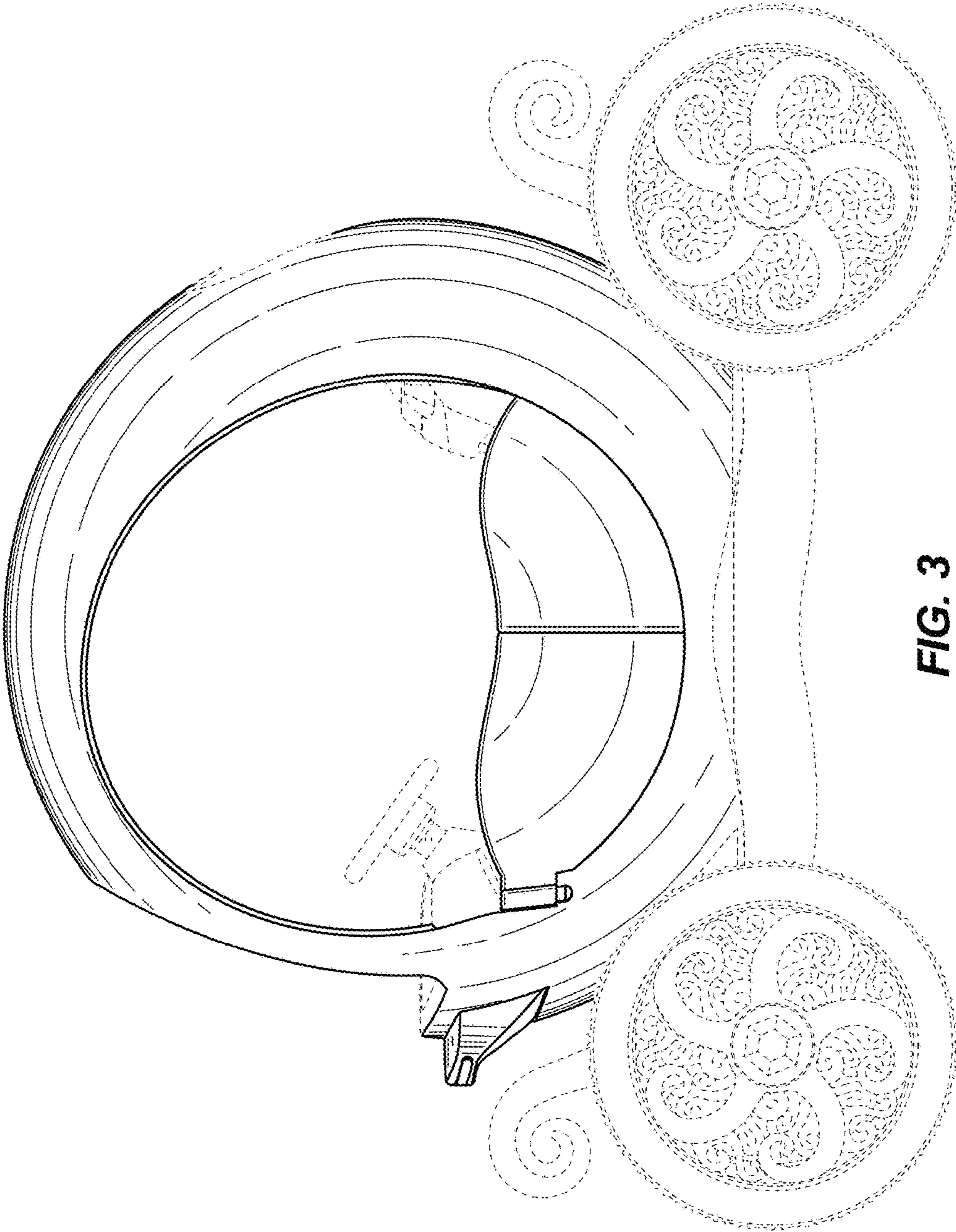

FIG. 3

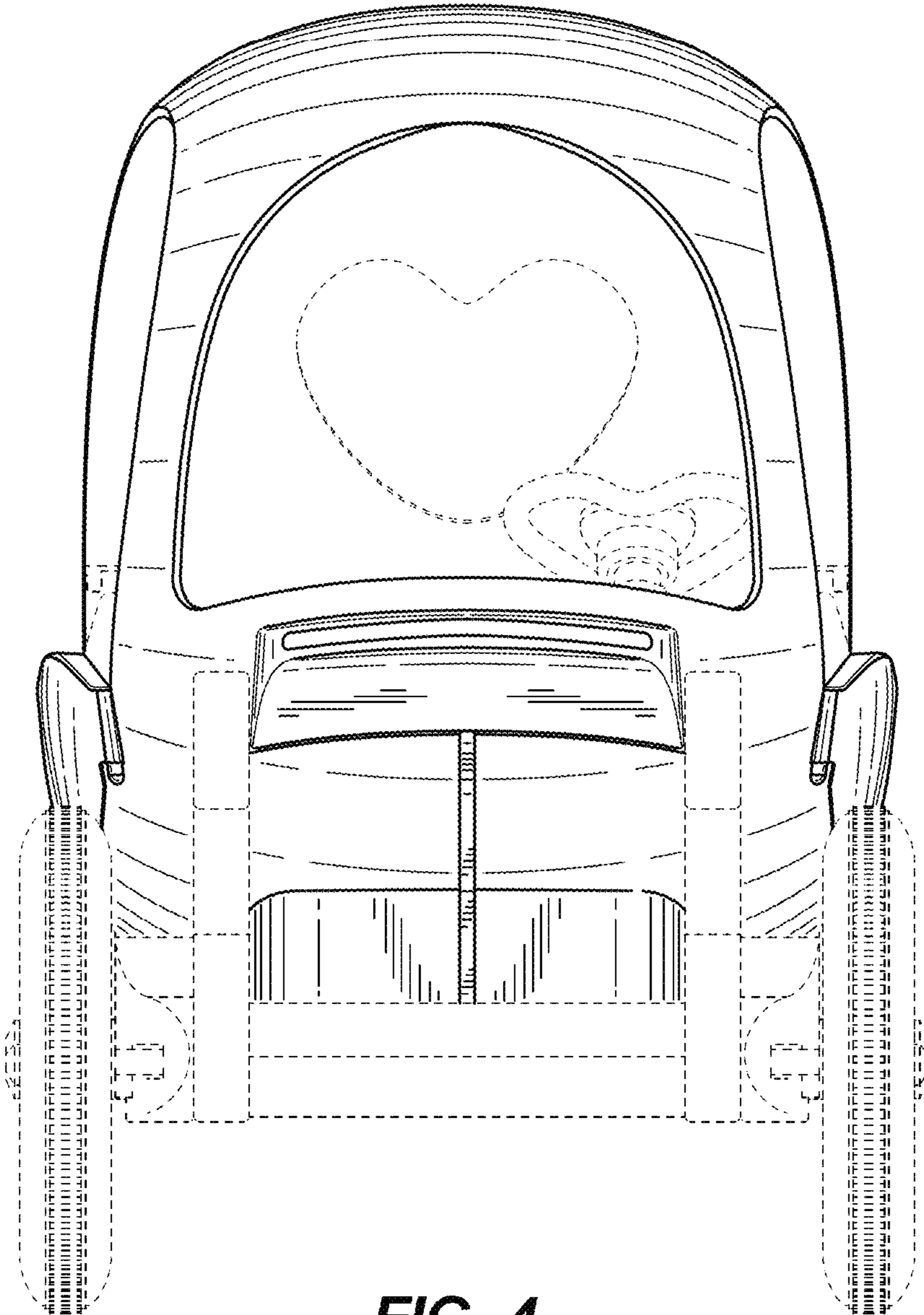

FIG. 4

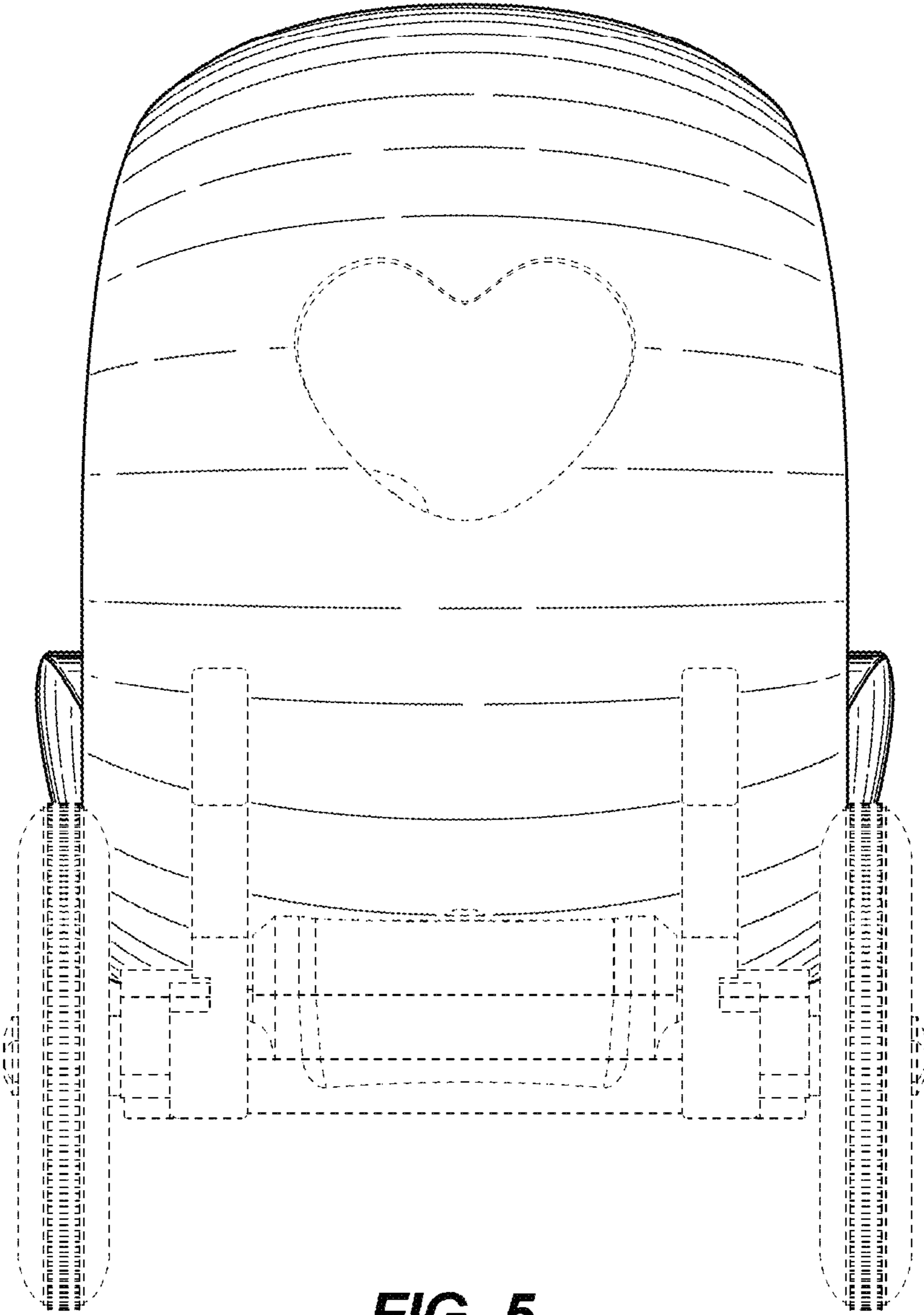

FIG. 5

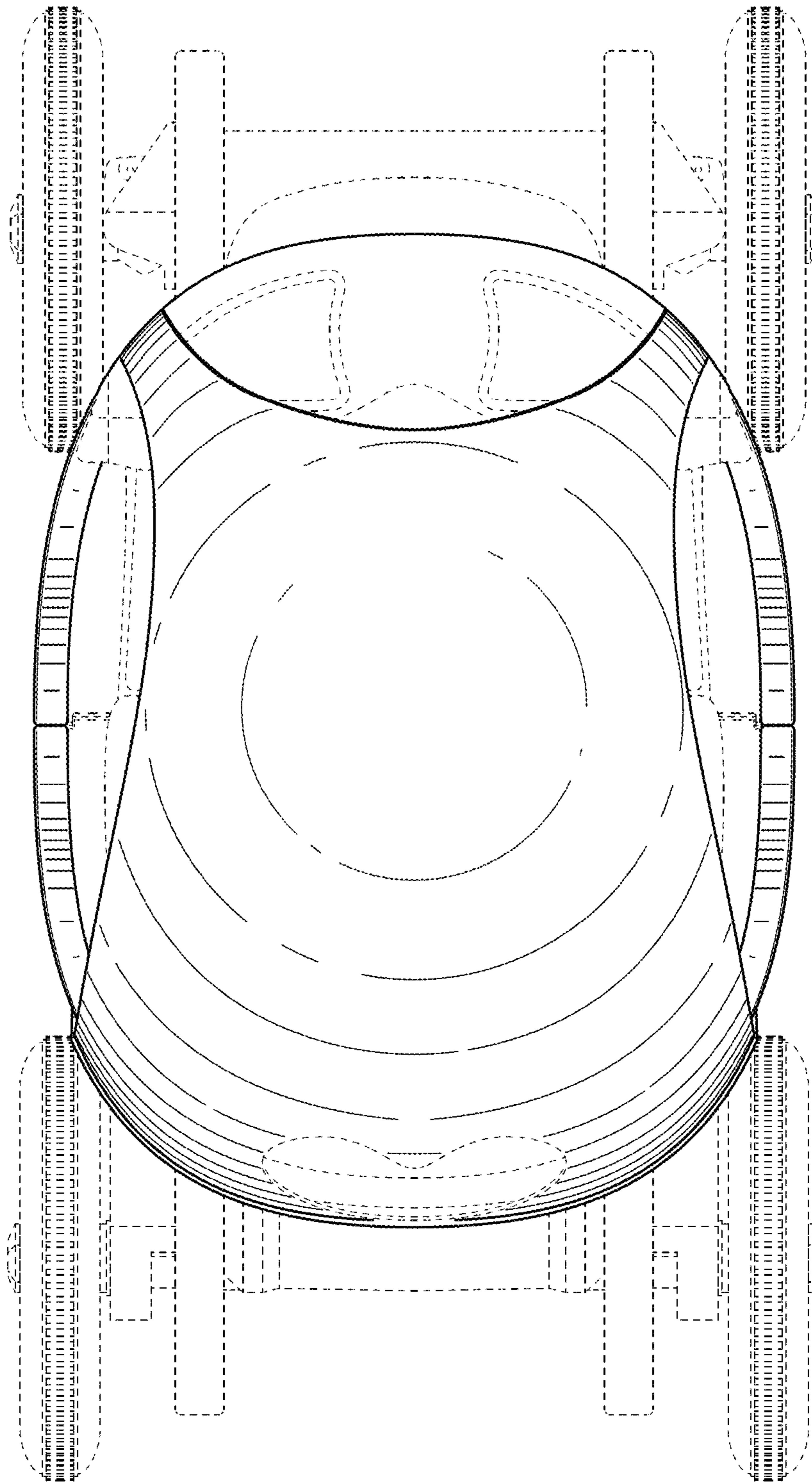

FIG. 6

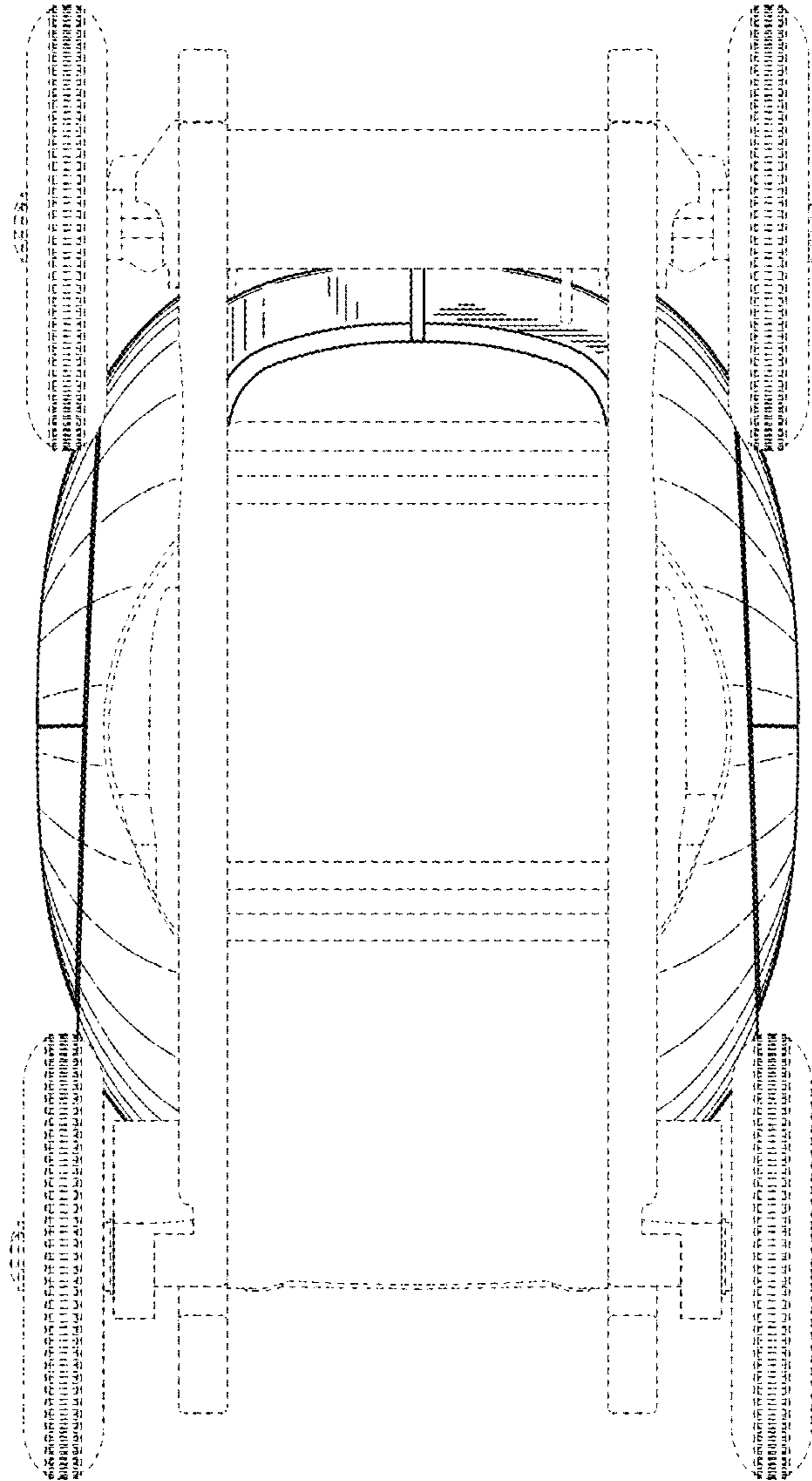

FIG. 7