

US00D795198S

(12) **United States Design Patent** (10) **Patent No.:** **US D795,198 S**
Murphy et al. (45) **Date of Patent:** **** Aug. 22, 2017**

(54) **BUSBAR**

(71) Applicant: **GENERAL ELECTRIC COMPANY**,
Schenectady, NY (US)

(72) Inventors: **Mark Allen Murphy**, Erie, PA (US);
Jason Daniel Kuttenkuler, Erie, PA
(US); **Sean Patrick Cillessen**,
Lawrence Park, PA (US); **Aiqin Jiang**,
Shanghai (CN)

(73) Assignee: **General Electric Company**,
Schenectady, NY (US)

(**) Term: **15 Years**

(21) Appl. No.: **29/586,344**

(22) Filed: **Dec. 2, 2016**

Related U.S. Application Data

(62) Division of application No. 29/566,032, filed on May
26, 2016, now Pat. No. Des. 782,981, which is a
division of application No. 29/542,280, filed on Oct.
13, 2015, now Pat. No. Des. 760,661, which is a
division of application No. 29/510,279, filed on Nov.
26, 2014, now Pat. No. Des. 743,901.

(51) **LOC (10) Cl.** **13-03**

(52) **U.S. Cl.**
USPC **D13/147; D13/154**

(58) **Field of Classification Search**
USPC D13/133, 146, 147, 154, 184, 199
See application file for complete search history.

(56) **References Cited**

U.S. PATENT DOCUMENTS

D782,981 S * 4/2017 Murphy D13/147

* cited by examiner

Primary Examiner — Daniel Bui

(74) *Attorney, Agent, or Firm* — Global Patent Operation;
John A. Kramer

(57) **CLAIM**

The ornamental design for a busbar, as shown and described.

DESCRIPTION

FIG. 1 is a perspective view of a busbar showing our new
design;

FIG. 2 is a top plan view thereof;

FIG. 3 is a bottom plan view thereof;

FIG. 4 is a front view thereof;

FIG. 5 is a rear view thereof;

FIG. 6 is a side view thereof; and,

FIG. 7 is an opposite side view thereof.

The broken line portion of the figure drawings is included to
show unclaimed subject matter only and forms no part of the
claimed design.

1 Claim, 4 Drawing Sheets

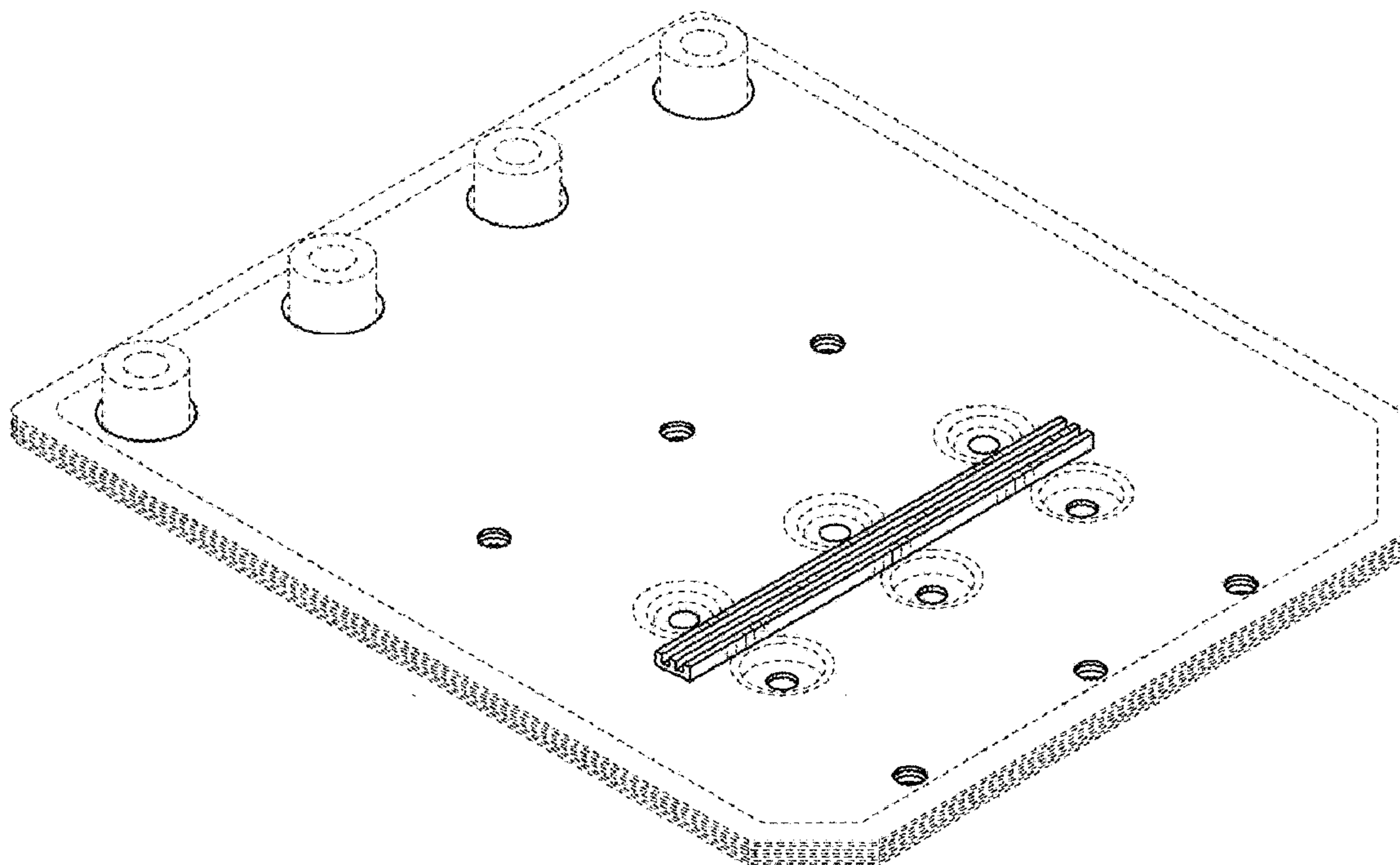

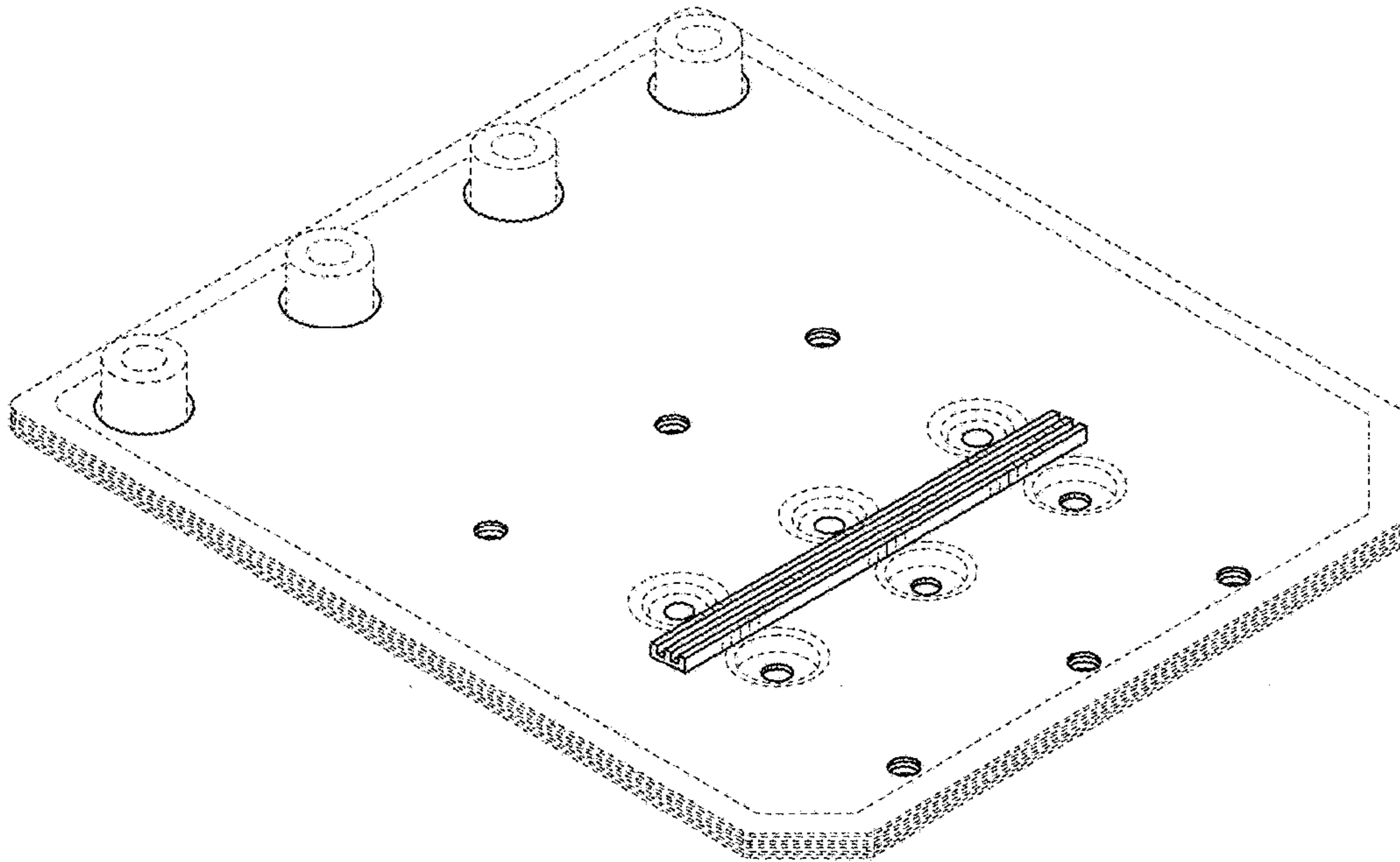

FIG. 1

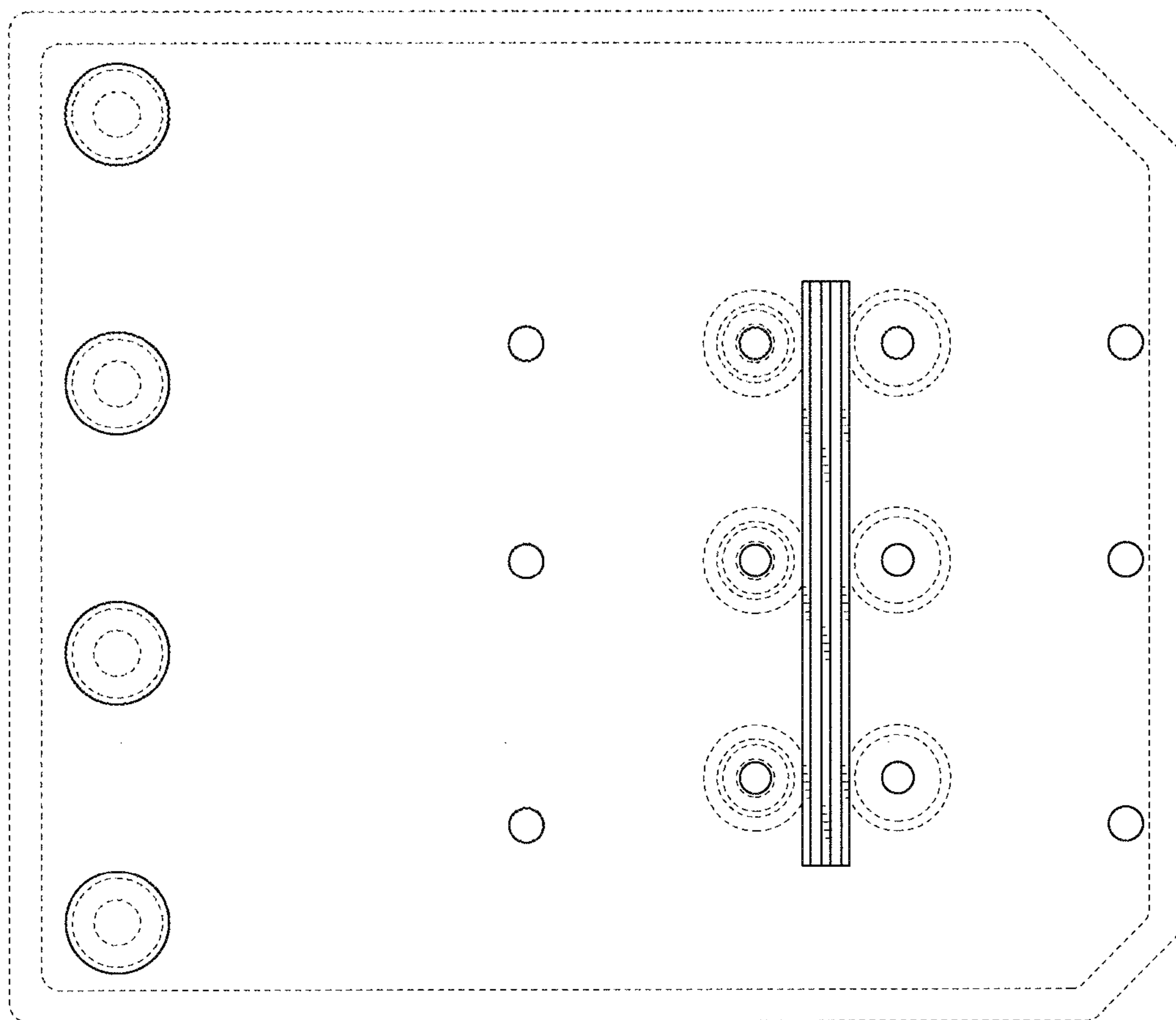

FIG. 2

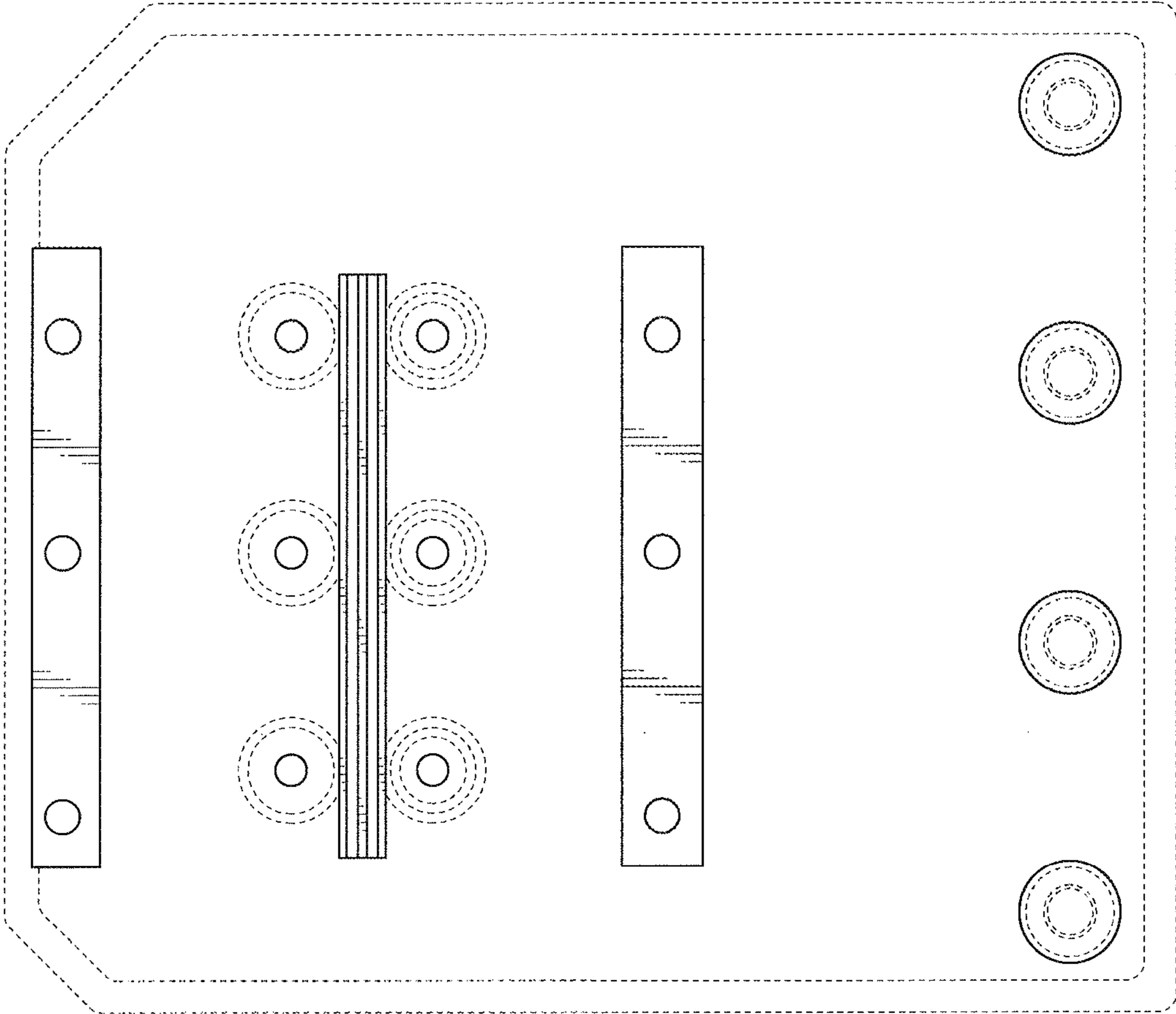

FIG. 3

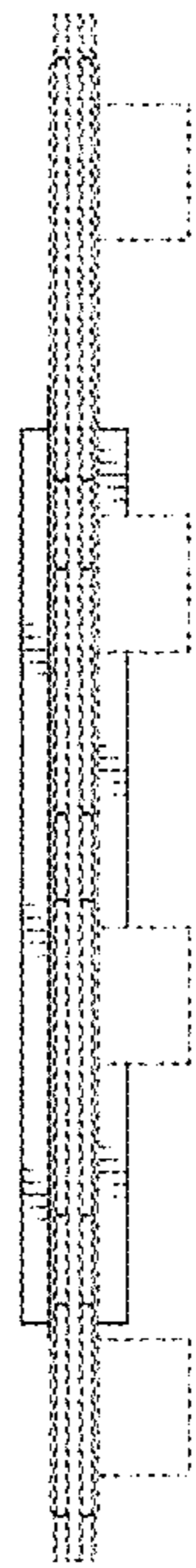

FIG. 4

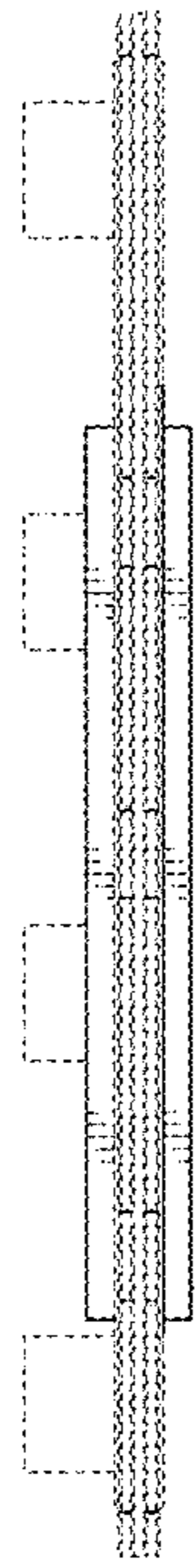

FIG. 5

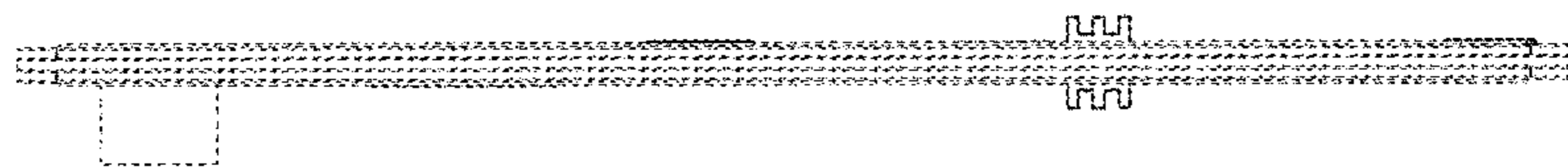

FIG. 6

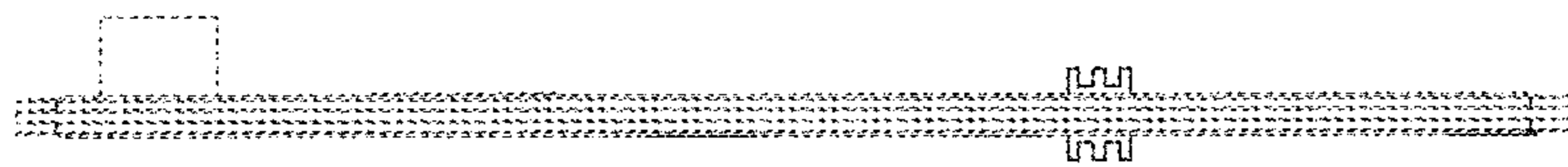

FIG. 7