



US00D795160S

(12) **United States Design Patent** (10) **Patent No.:** **US D795,160 S**  
**Koppenwallner** (45) **Date of Patent:** **\*\* Aug. 22, 2017**

(54) **AIRPLANE**  
(71) Applicant: **Johann Schwöller**, Strasswalchen (AT)  
(72) Inventor: **Martin Koppenwallner**, Salzburg (AT)  
(73) Assignee: **Johann Schwöller**, Strasswalchen (AT)  
(\*\*) Term: **15 Years**

(21) Appl. No.: **29/561,393**

(22) Filed: **Apr. 15, 2016**

(51) **LOC (10) Cl.** ..... **12-07**

(52) **U.S. Cl.**  
USPC ..... **D12/343**

(58) **Field of Classification Search**  
USPC ..... D12/16.1, 319-324, 326-345; D21/436,  
D21/441, 443, 444, 446, 447, 448, 449,  
D21/450, 451, 452, 453  
CPC ..... B64C 1/062; B64C 39/024; B64C 27/08;  
B64C 29/00; B64C 39/00; B64C 23/00  
See application file for complete search history.

(56) **References Cited**

**U.S. PATENT DOCUMENTS**

D143,822 S *	2/1946	Johnson	.....	244/73 R
D180,297 S *	5/1957	Schmued	.....	D12/343
D292,909 S *	11/1987	Drake	.....	D12/319
D317,432 S *	6/1991	Cummings	.....	D12/337
D317,897 S *	7/1991	Antonov	.....	D12/319
D392,937 S *	3/1998	Brichard	.....	D12/319
D418,105 S *	12/1999	Margaritoff	.....	D12/319
D446,764 S *	8/2001	Panatov	.....	D12/324
D471,853 S *	3/2003	Lucchesini	.....	D12/319
D516,007 S *	2/2006	Vigneron	.....	D12/319
D596,267 S *	7/2009	Colgren	.....	D12/319

D599,727 S *	9/2009	Couvelaire	.....	D12/343
D628,528 S *	12/2010	Cabezas Carrasco	.....	D12/319
D651,156 S *	12/2011	Gundlach	.....	D12/319
D665,331 S *	8/2012	Sands	.....	D12/319
D690,254 S *	9/2013	Manzhelii	.....	D12/319
D691,547 S *	10/2013	Hall	.....	D12/319
D706,678 S *	6/2014	Earon	.....	D12/16.1
D708,563 S *	7/2014	Colten	.....	D12/319
D717,227 S *	11/2014	Herzberger	.....	D12/324
D725,548 S *	3/2015	Herald	.....	D12/16.1
D725,576 S *	3/2015	Vickers	.....	D12/3
D739,807 S *	9/2015	Strand	.....	D12/324
D760,638 S *	7/2016	Beskar	.....	D12/344
D762,157 S *	7/2016	Faure	.....	D12/342
D763,733 S *	8/2016	Gattelli	.....	D12/16.1

\* cited by examiner

*Primary Examiner* — Robert M Spear

*Assistant Examiner* — Marissa J Cash

(74) *Attorney, Agent, or Firm* — HoustonHogle LLP

(57) **CLAIM**

The ornamental design for an airplane, as shown and described.

**DESCRIPTION**

FIG. 1 is a top perspective view of an airplane showing my new design;

FIG. 2 is a first bottom perspective view thereof;

FIG. 3 is a second bottom perspective view thereof;

FIG. 4 is a front elevation view thereof;

FIG. 5 is a top elevation view thereof;

FIG. 6 is a left side elevation view thereof, the right side elevation view being a mirror image of that shown;

FIG. 7 is a rear elevation view thereof; and,

FIG. 8 is a partial front elevation view thereof.

**1 Claim, 8 Drawing Sheets**

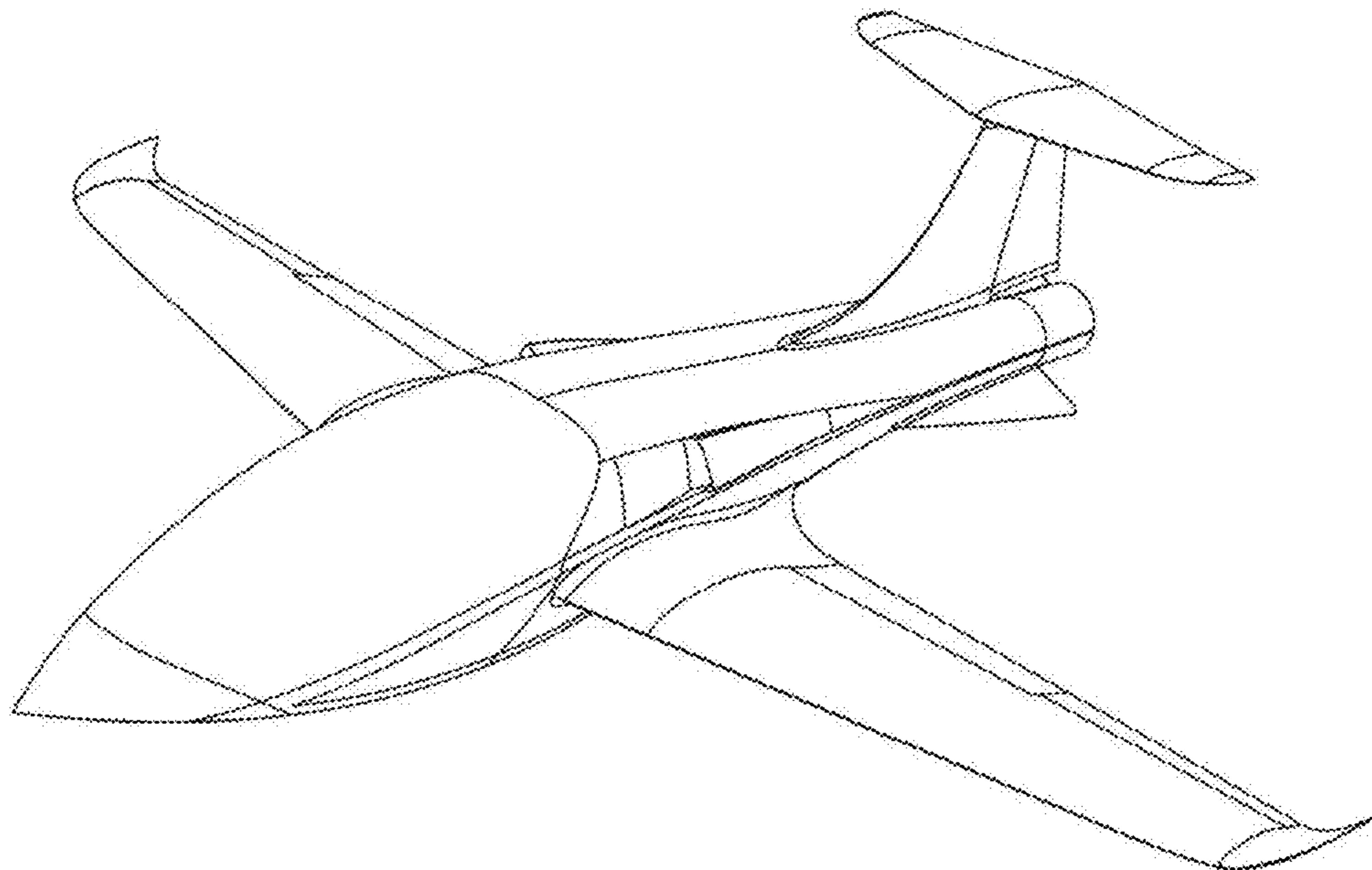

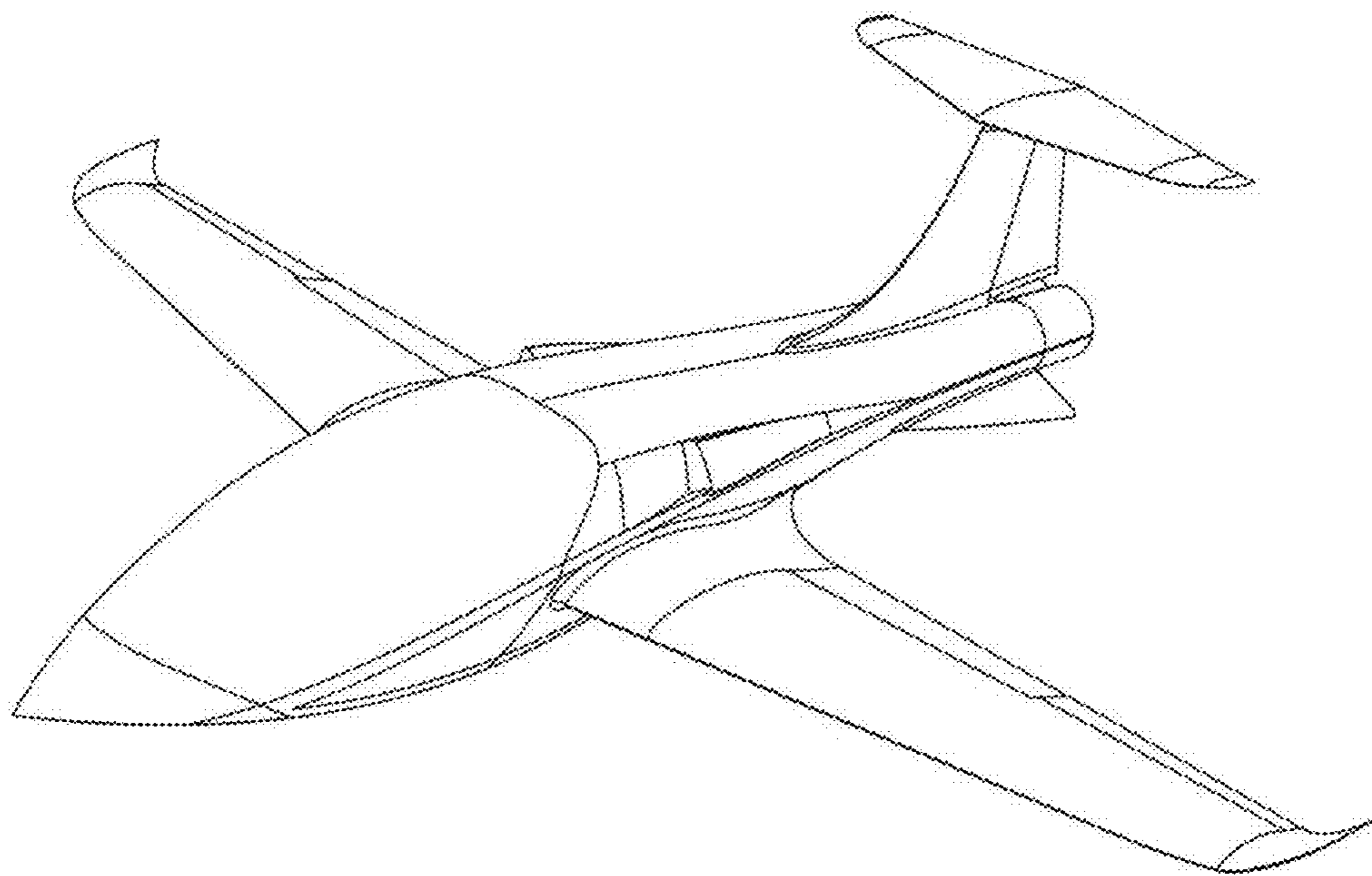

FIG. 1

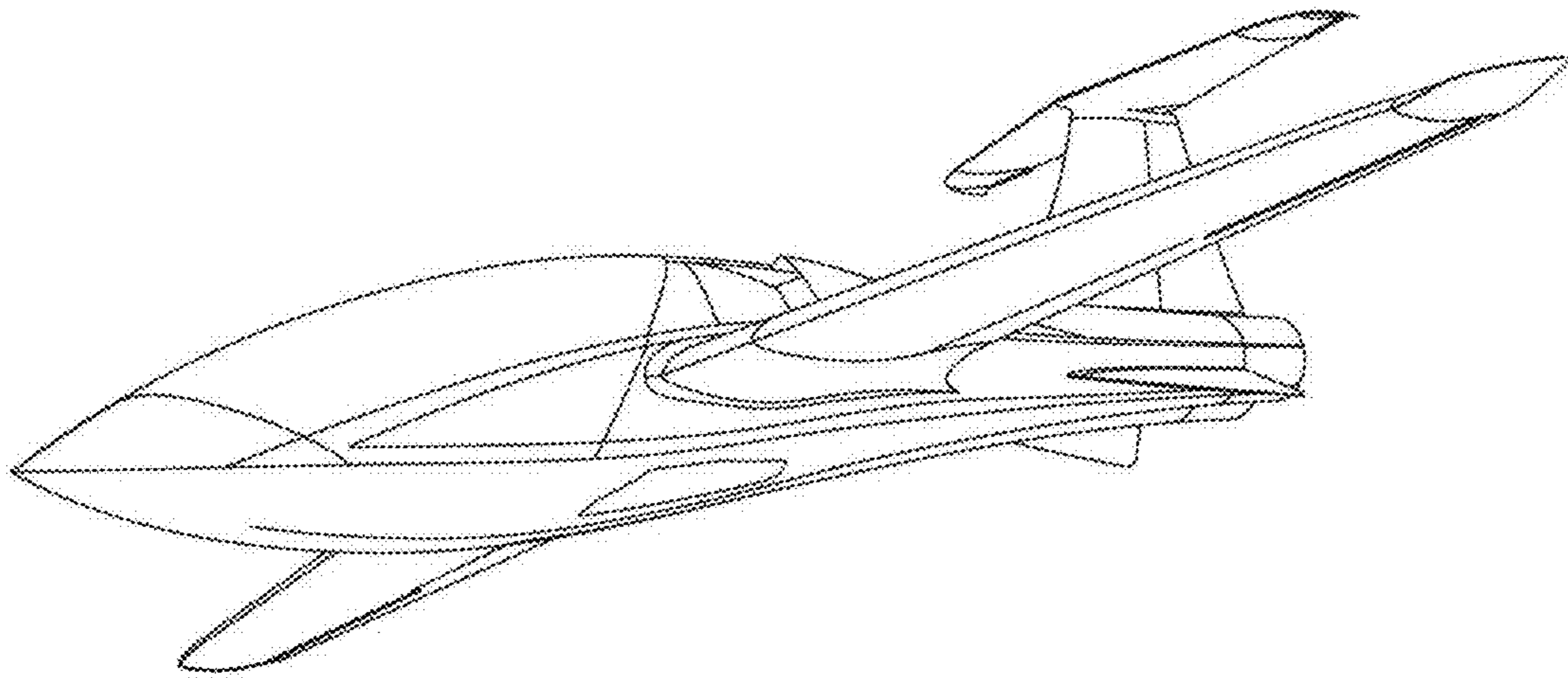

FIG. 2

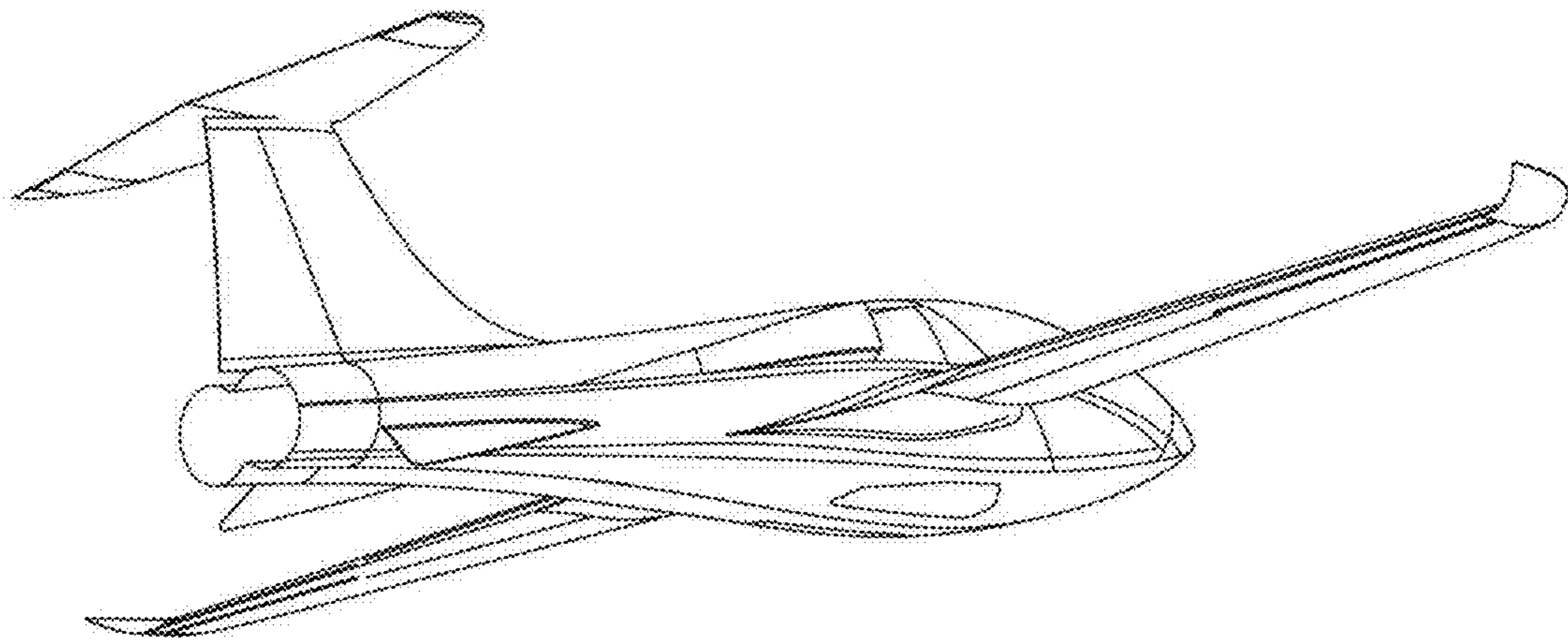

FIG. 3

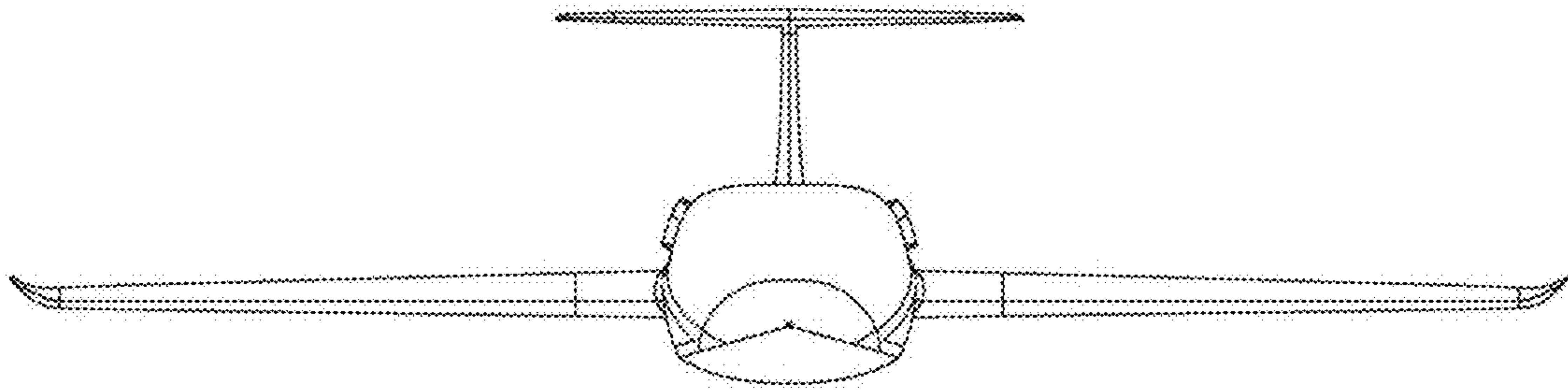

FIG. 4

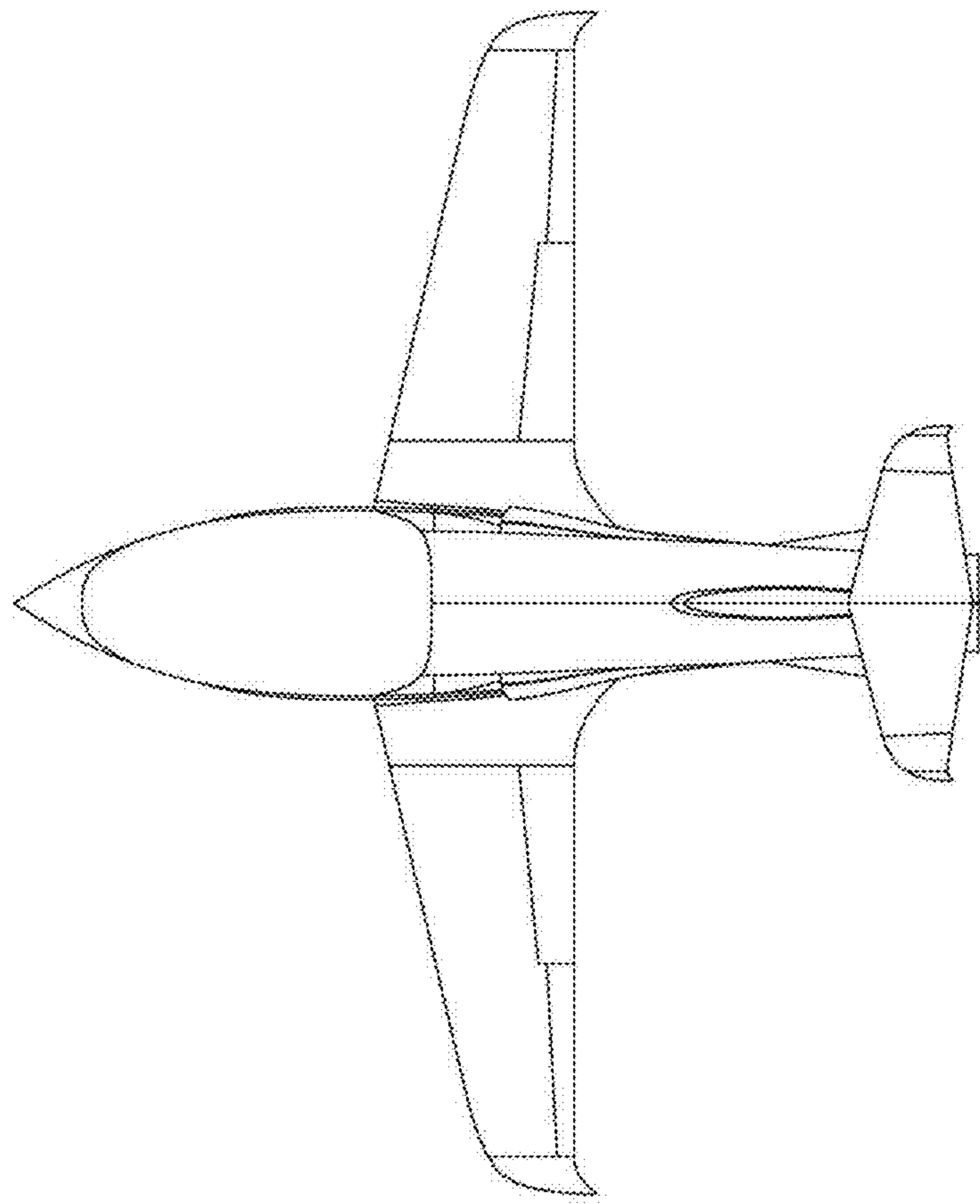

FIG. 5

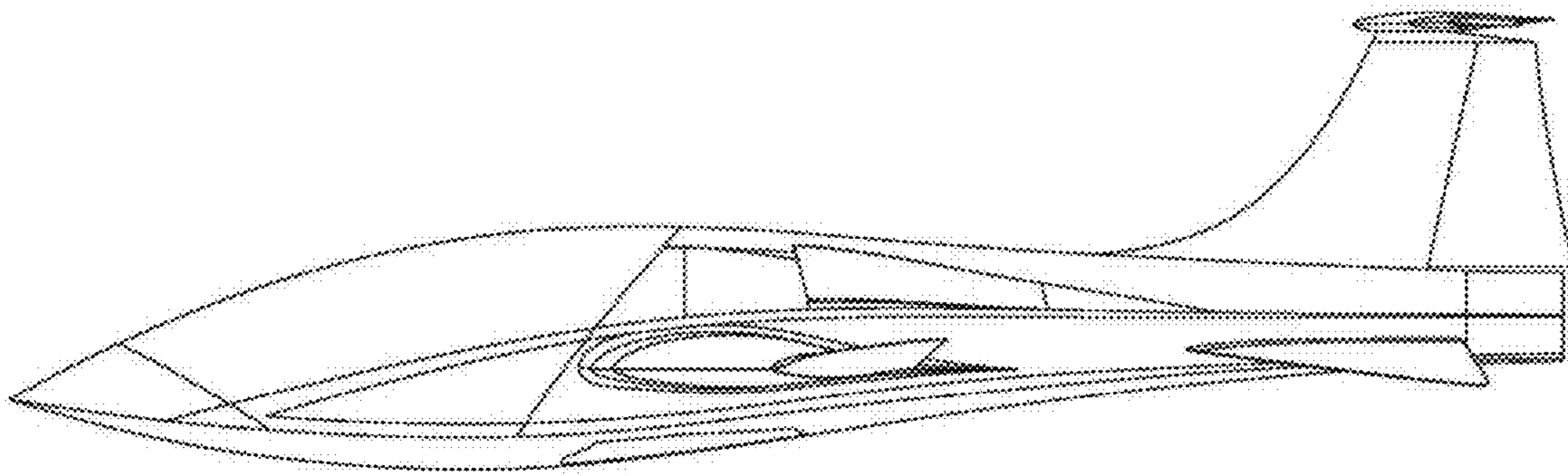

FIG. 6

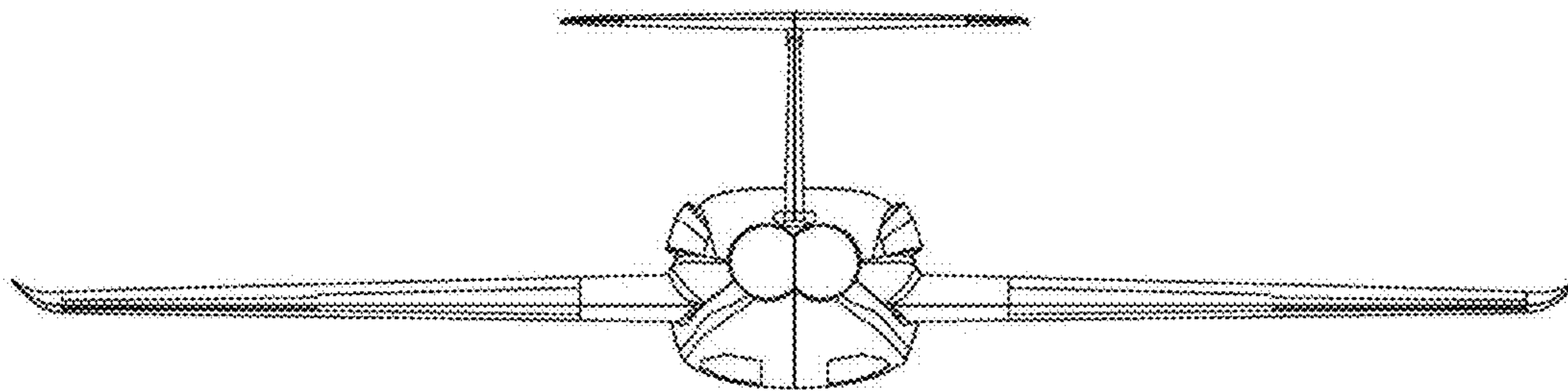

FIG. 7



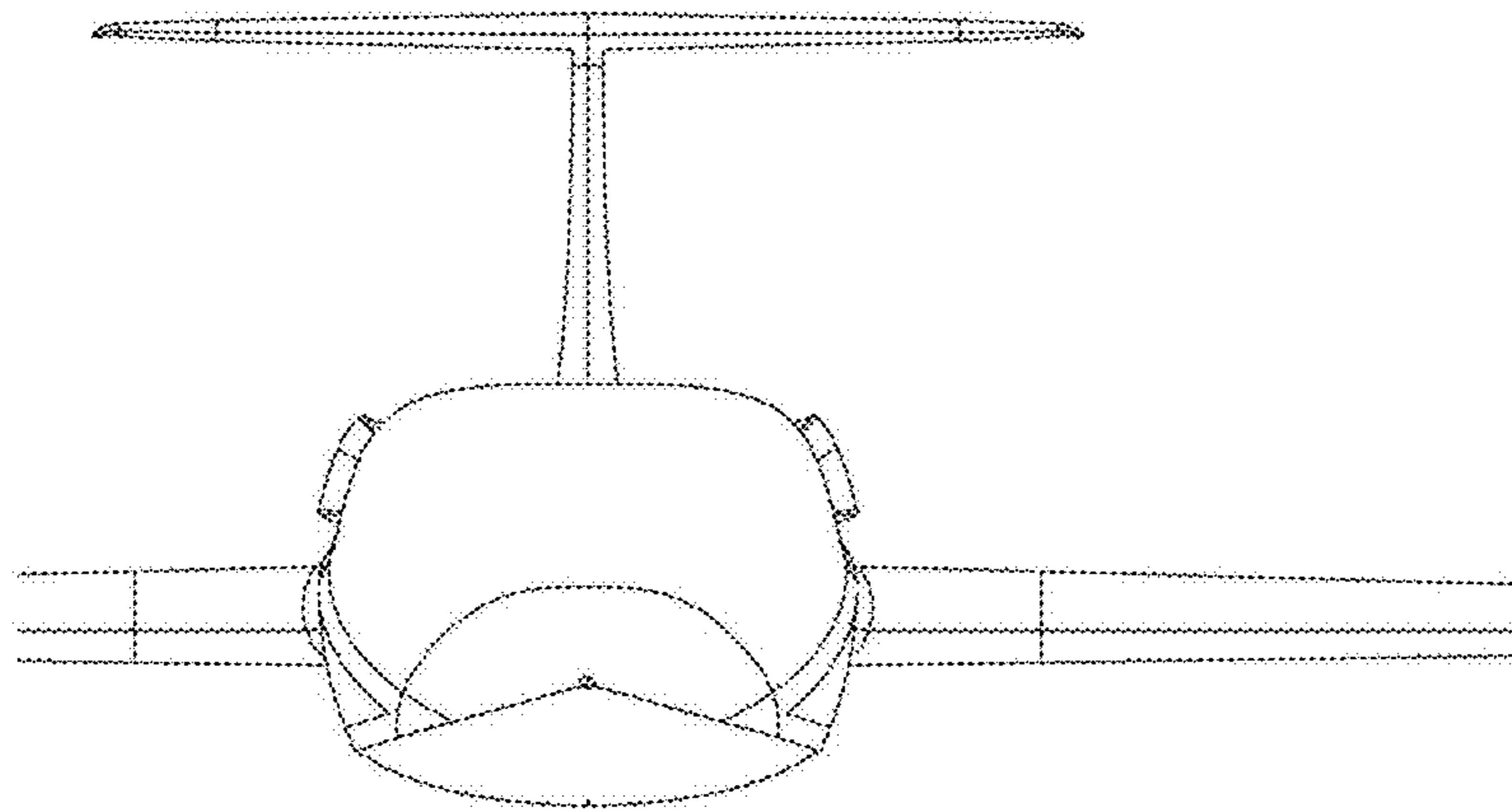

FIG. 8