

US00D795141S

(12) **United States Design Patent** (10) **Patent No.:** **US D795,141 S**  
**Ikeda et al.** (45) **Date of Patent:** **\*\* Aug. 22, 2017**

(54) **REAR BUMPER FOR A MOTOR VEHICLE**

(71) Applicants: **Gen Ikeda**, Nagoya (JP); **Hideaki Suzuki**, Okazaki (JP)

(72) Inventors: **Gen Ikeda**, Nagoya (JP); **Hideaki Suzuki**, Okazaki (JP)

(73) Assignee: **Toyota Jidosha Kabushiki Kaisha**, Toyota-shi, Aichi-ken (JP)

(\*\*) Term: **15 Years**

(21) Appl. No.: **29/582,827**

(22) Filed: **Oct. 31, 2016**

**Related U.S. Application Data**

(62) Division of application No. 29/536,836, filed on Aug. 19, 2015.

(30) **Foreign Application Priority Data**

Feb. 20, 2015 (JP) ..... 2015-003451  
Feb. 20, 2015 (JP) ..... 2015-003452  
Feb. 20, 2015 (JP) ..... 2015-003453

(51) **LOC (10) Cl.** ..... **12-08**

(52) **U.S. Cl.**  
USPC ..... **D12/169**

(58) **Field of Classification Search**  
USPC ..... D12/86-92, 163-172; 293/102-155;  
296/35.2, 193.09, 193.1, 203.02  
CPC ..... B60R 19/02; B60R 19/023; B60R 19/18;  
B60R 19/24; B60R 19/44; B60R 19/48;  
B60R 19/56; B60R 2019/527; B60R  
2019/1886

See application file for complete search history.

(56) **References Cited**

**U.S. PATENT DOCUMENTS**

D566,017 S \* 4/2008 Pfeiffer ..... D12/169  
D575,690 S 8/2008 Suzuki

D586,271 S 2/2009 Futschik  
D590,308 S 4/2009 Futschik  
D600,605 S \* 9/2009 Lamm ..... D12/169  
D626,042 S \* 10/2010 Yamazaki ..... D12/169  
D628,943 S \* 12/2010 Lee ..... D12/169  
D633,418 S 3/2011 Frei  
D635,067 S \* 3/2011 Kozai ..... D12/169  
D635,068 S \* 3/2011 Neuchi ..... D12/169  
D640,613 S 6/2011 Bauer  
D653,593 S 2/2012 Nishihama  
D663,657 S 7/2012 Frenzel  
D683,285 S \* 5/2013 Yoshida ..... D12/169

(Continued)

**OTHER PUBLICATIONS**

Netcarshow.com; URL: <http://www.netcarshow.com/lexus/2015-rc/>; Model: Lexus RC (2015); Mfg.: Lexus; available on at least Apr. 8, 2014.

(Continued)

*Primary Examiner* — Cathron Brooks

*Assistant Examiner* — Christian P McLean

(74) *Attorney, Agent, or Firm* — Finnegan, Henderson, Farabow, Garrett & Dunner, LLP

(57) **CLAIM**

The ornamental design for a rear bumper for a motor vehicle, as shown and described.

**DESCRIPTION**

FIG. 1 is a front perspective view of a rear bumper for a motor vehicle showing our new design;  
FIG. 2 is a front view thereof;  
FIG. 3 is a rear view thereof;  
FIG. 4 is a right side view thereof;  
FIG. 5 is a left side view thereof;  
FIG. 6 is a top plan view thereof; and,  
FIG. 7 is a bottom plan view thereof.

**1 Claim, 7 Drawing Sheets**

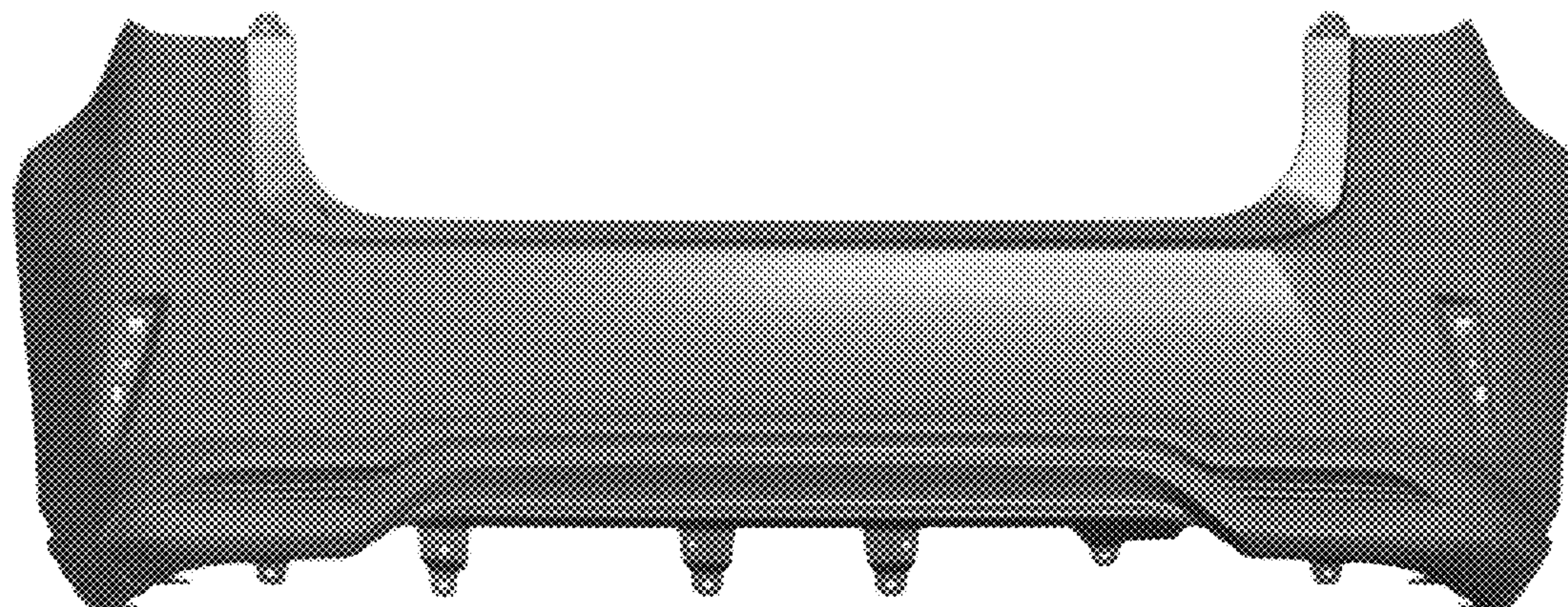

(56)

References Cited

U.S. PATENT DOCUMENTS

D695,162 S	12/2013	Scheinutte	
D695,164 S	12/2013	Futschik	
D696,159 S *	12/2013	Borkert .....	D12/92
D696,979 S *	1/2014	Dyson .....	D12/92
D698,290 S	1/2014	Mori	
D709,808 S *	7/2014	Ueda .....	D12/169
D711,793 S *	8/2014	Nagasaka .....	D12/169
D718,680 S	12/2014	Galante	
D721,306 S	1/2015	George	
D724,493 S	3/2015	Kobayashi	
D725,009 S	3/2015	Hirai	
D725,010 S	3/2015	Takei	
D736,125 S	8/2015	Kamiura	
D736,126 S	8/2015	Hammoud	
D736,127 S	8/2015	Hammoud	
D743,855 S	11/2015	Miyazawa	
D751,463 S	3/2016	Futschik	
D773,352 S *	12/2016	Munakata .....	D12/169
D773,353 S *	12/2016	Munakata .....	D12/169
D773,355 S *	12/2016	Kawaguchi .....	D12/169
D779,394 S *	2/2017	Suga .....	D12/164
D779,395 S *	2/2017	Horie .....	D12/169

OTHER PUBLICATIONS

Netcarshow.com; URL: <http://www.netcarshow.com/mercedes-benz/2013-glk-class/>; Model: Mercedes-Benz GLK (2013); Mfg.: Mercedes-Benz; available on at least Apr. 8, 2014.

netcarshow.com; URL: [http://www.netcarshow.com/peugeot/2012-urban\\_crossover\\_concept/](http://www.netcarshow.com/peugeot/2012-urban_crossover_concept/); Model: Peugeot Urban Crossover Concept; Mfg: Peugeot; available on at least Apr. 8, 2014.

Netcarshow.com; URL: [http://www.netcarshow.com/lexus/2015-rc\\_f\\_sport/](http://www.netcarshow.com/lexus/2015-rc_f_sport/); Model: Lexus RC F Sport (2015); Mfg.: Lexus; available on at least May 28, 2014.

Netcarshow.com; URL: <http://www.netcarshow.com/mercedes-benz/2015-gla-class/>; Model: Mercedes-Benz GLA (2015); Mfg.: Mercedes-Benz; available on at least May 28, 2014.

netcarshow.com; URL: [http://www.netcarshow.com/nissan/2013-resonance\\_concept/](http://www.netcarshow.com/nissan/2013-resonance_concept/); Model: Nissan Resonance Concept; Mfg: Nissan; available on at least May 28, 2014.

Netcarshow.com; URL: <http://www.netcarshow.com/lexus/2014-is/>; Model: Lexus IS (2014); Mfg.: Lexus; May 28, 2014.

Netcarshow.com; URL: [http://www.netcarshow.com/honda/2013-urban\\_suv\\_concept/](http://www.netcarshow.com/honda/2013-urban_suv_concept/); Model: Honda Urban SUV Concept (2013); Mfg.: Honda; available on at least May 28, 2014.

\* cited by examiner



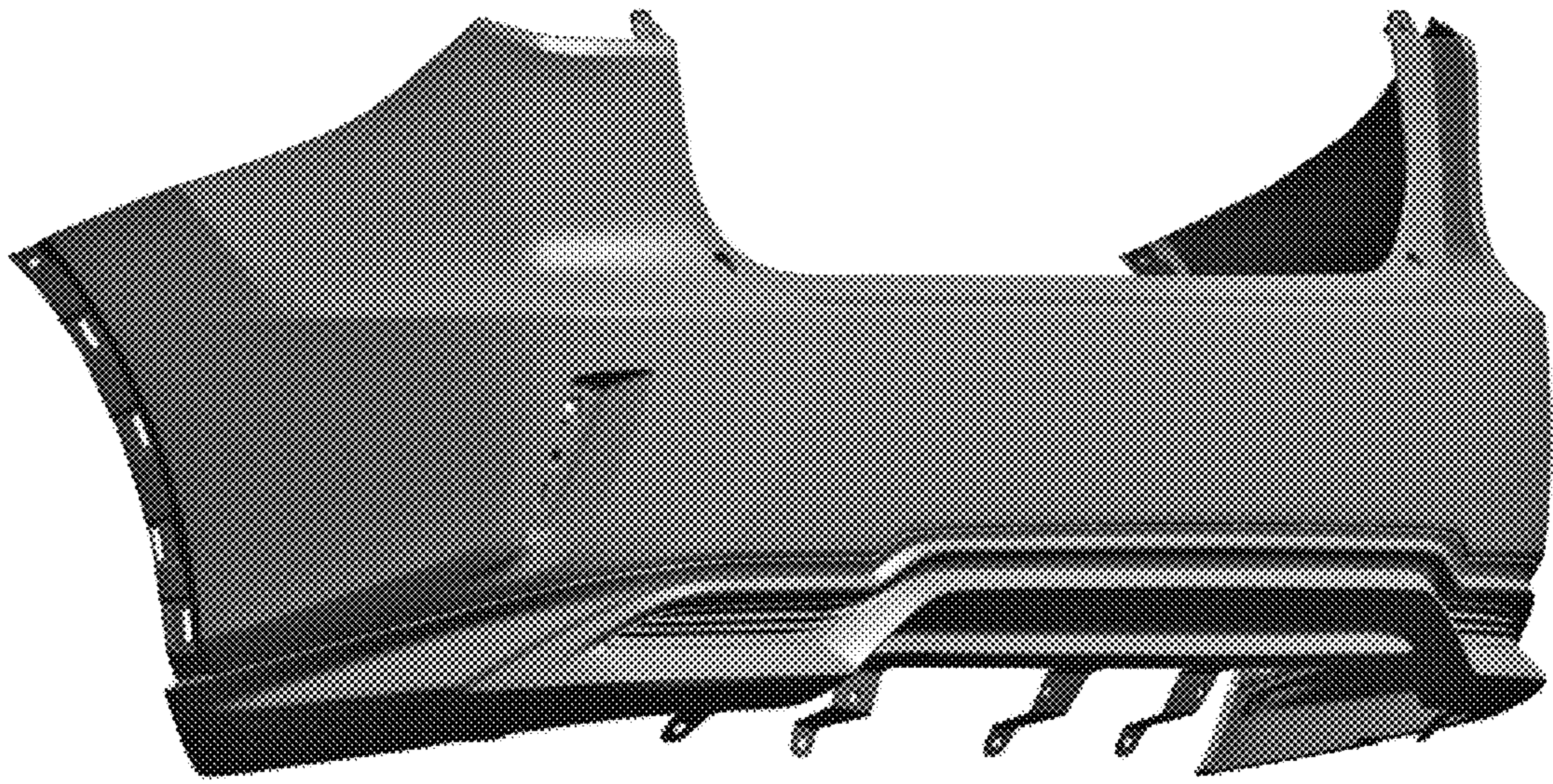

**FIG. 1**

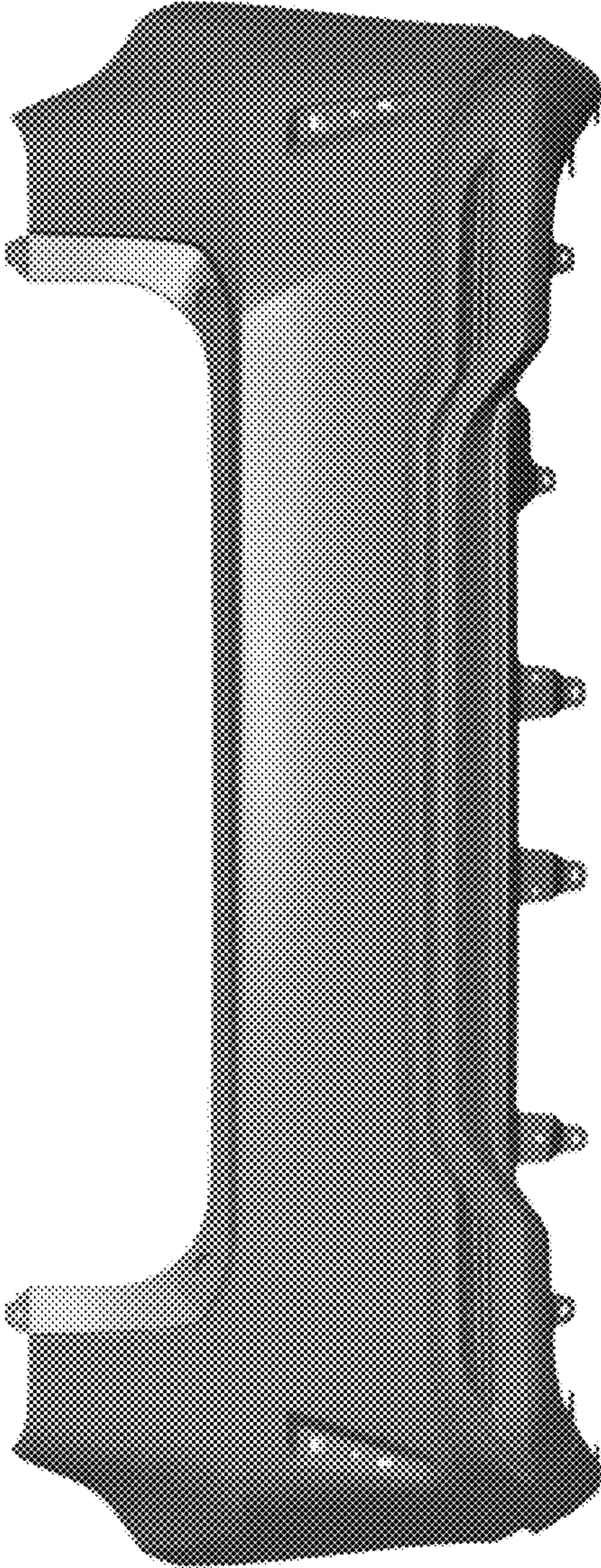
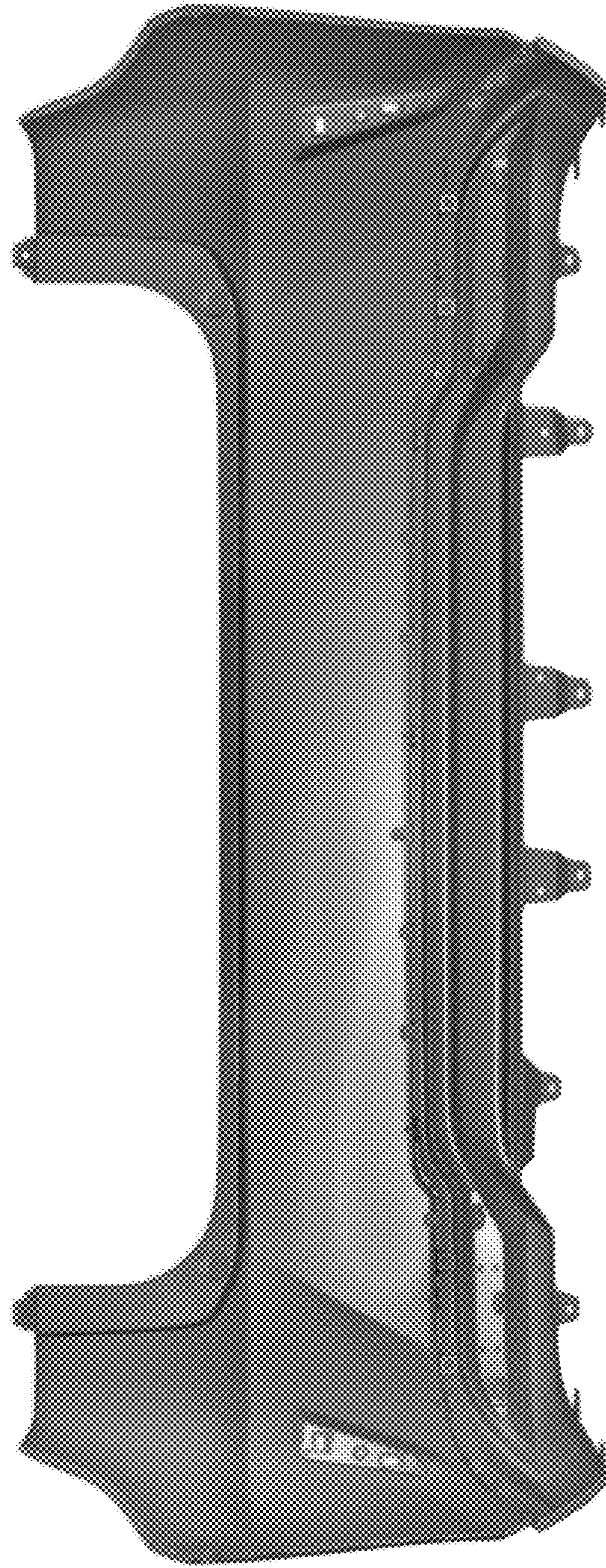
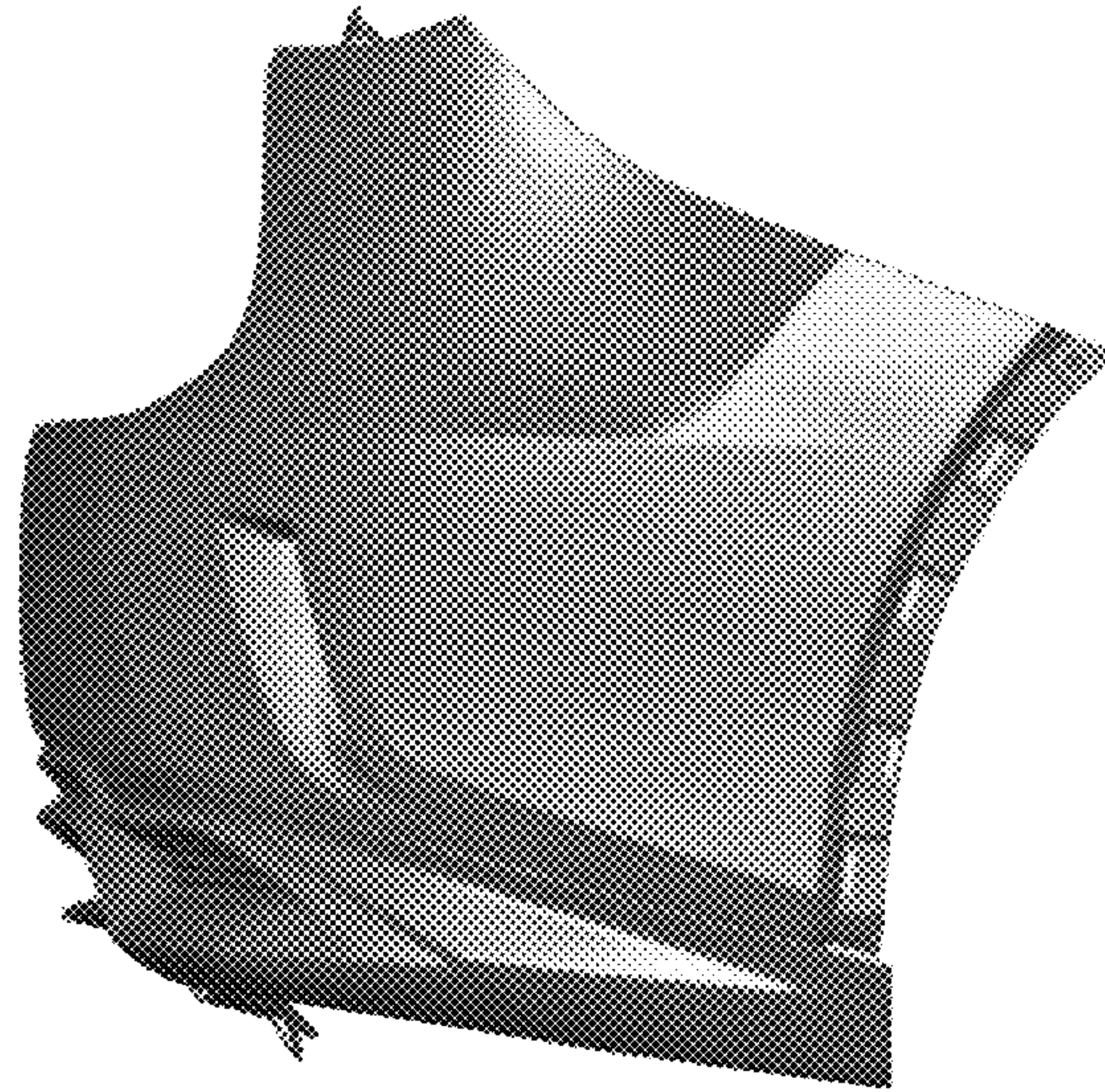

FIG. 2



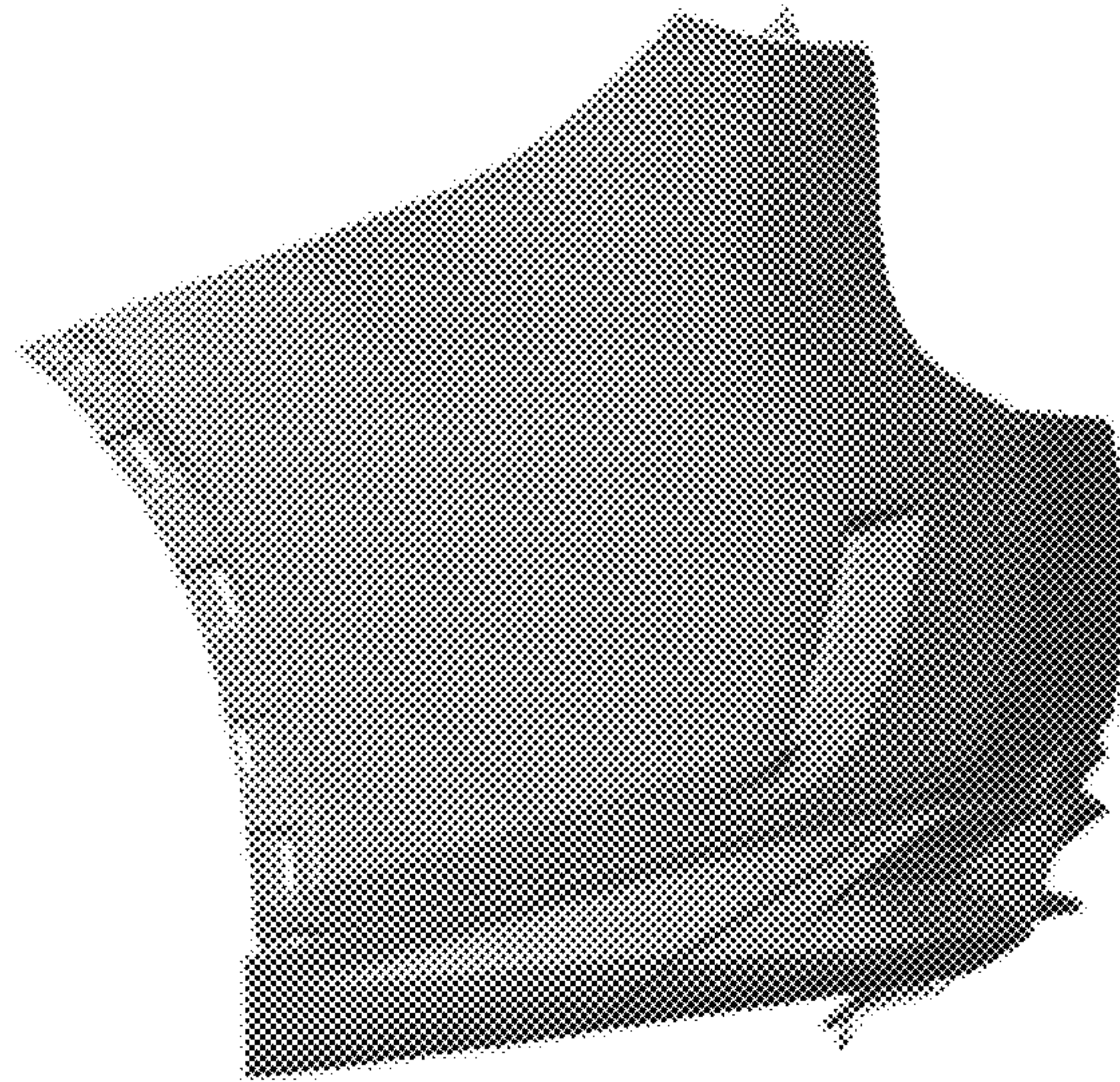

**FIG. 3**

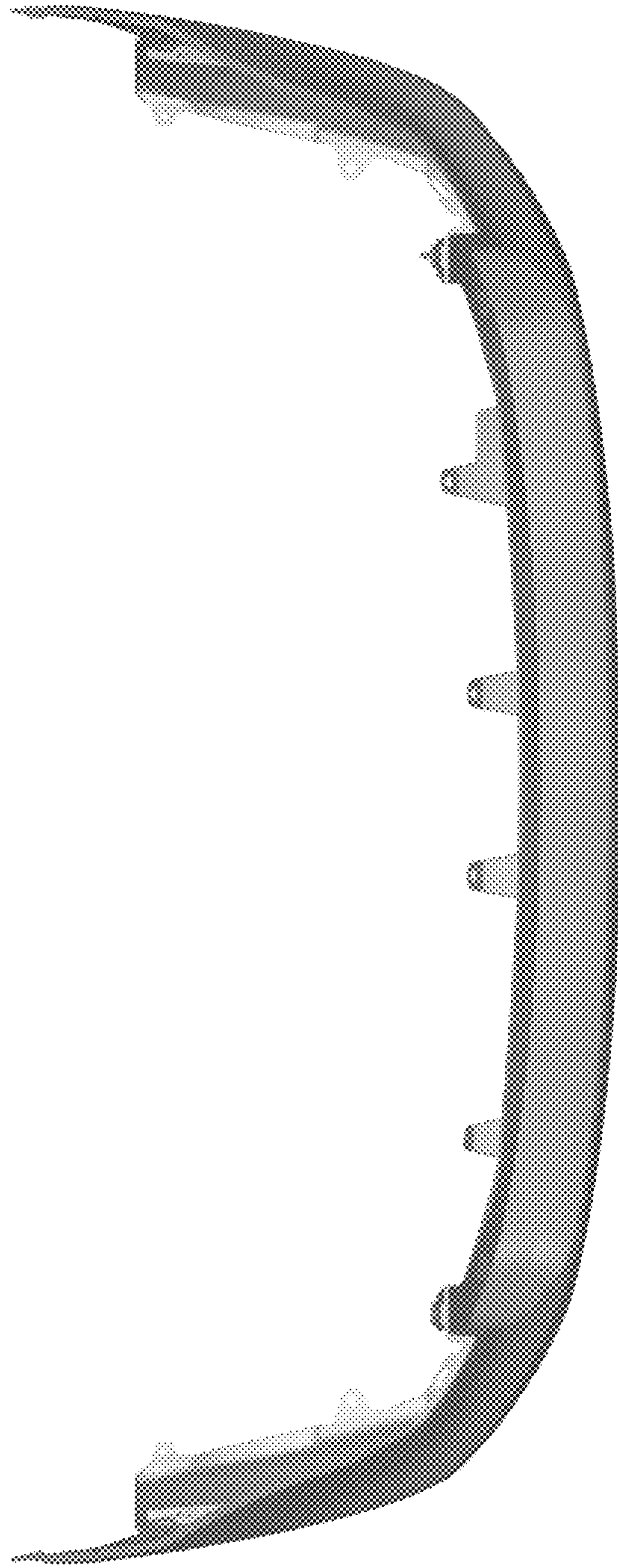

**FIG. 4**





***FIG. 5***



**FIG. 6**



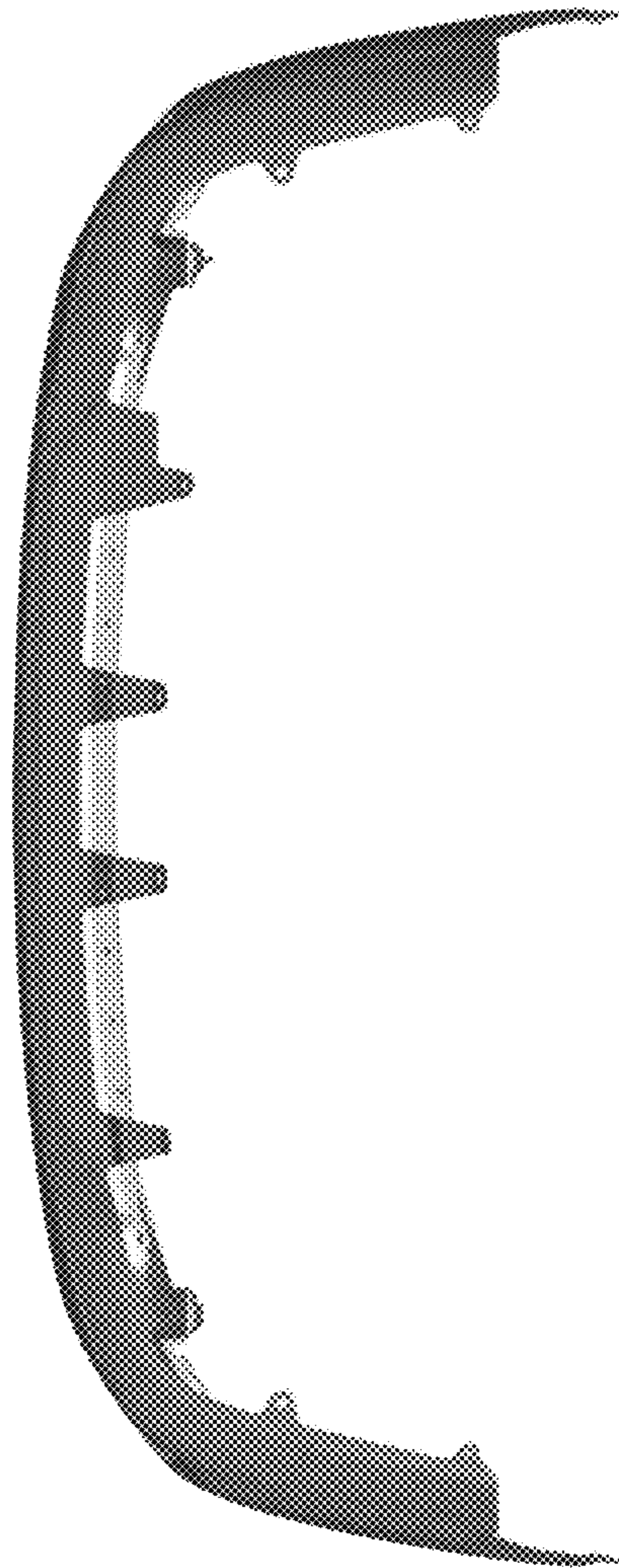

FIG. 7

UNITED STATES PATENT AND TRADEMARK OFFICE  
**CERTIFICATE OF CORRECTION**

PATENT NO. : D795,141 S  
APPLICATION NO. : 29/582827  
DATED : August 22, 2017  
INVENTOR(S) : Gen Ikeda et al.

Page 1 of 2

It is certified that error appears in the above-identified patent and that said Letters Patent is hereby corrected as shown below:

In the Drawings

Replace Fig. 7 with new Fig. 7 attached.

Signed and Sealed this  
Third Day of July, 2018

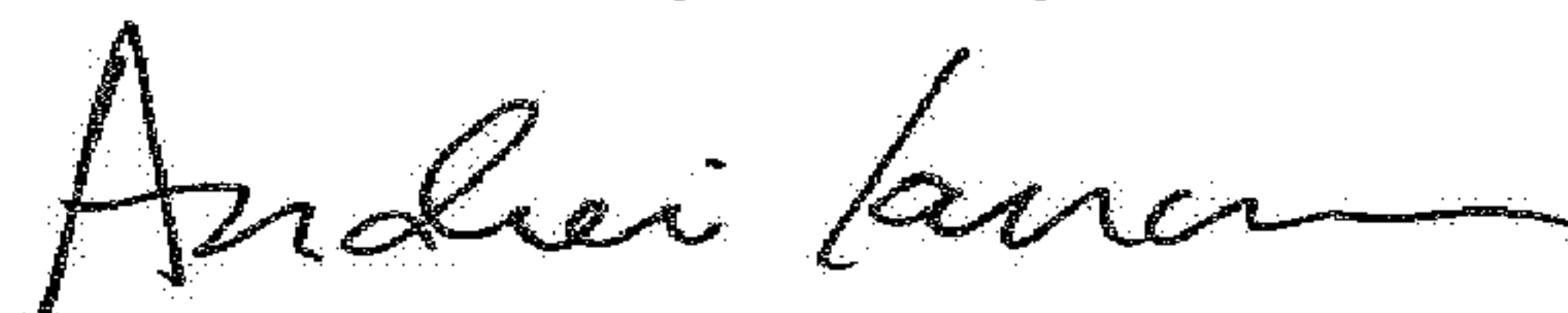

Andrei Iancu  
*Director of the United States Patent and Trademark Office*



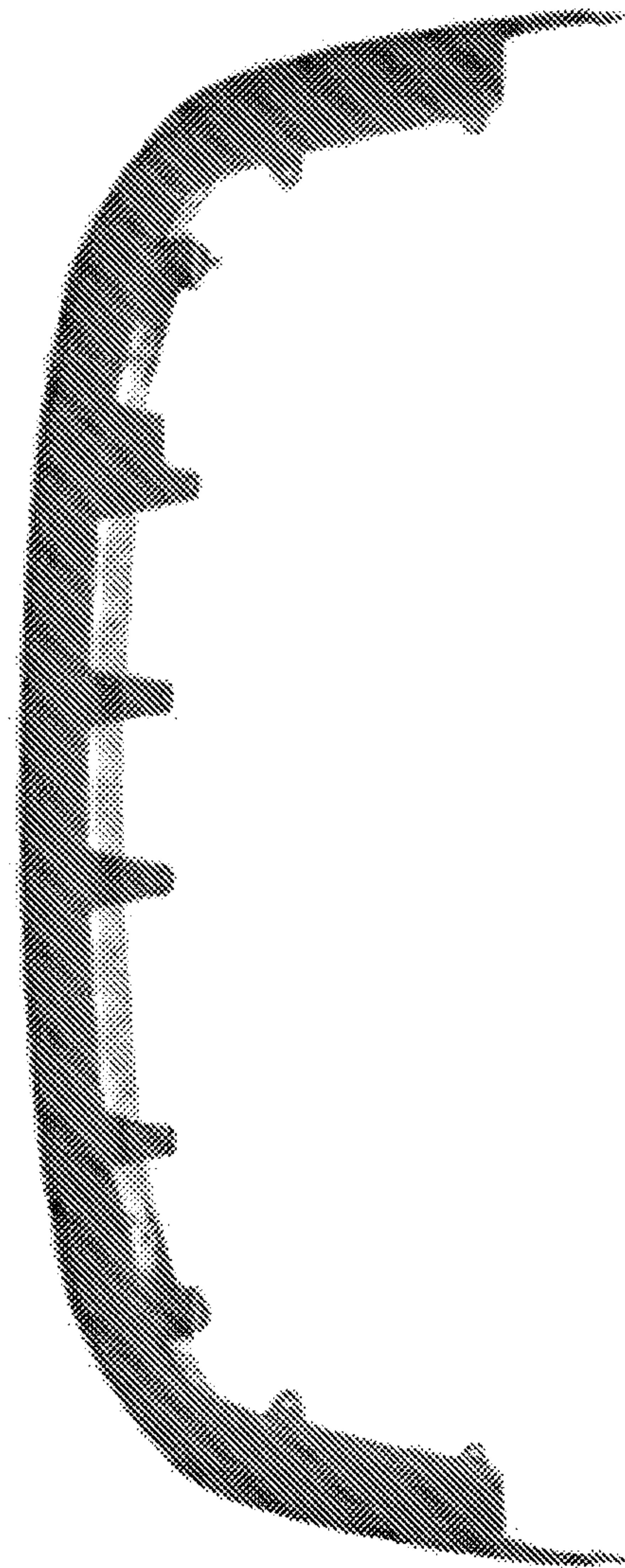

FIG. 7

UNITED STATES PATENT AND TRADEMARK OFFICE  
**CERTIFICATE OF CORRECTION**

PATENT NO. : D795,141 S  
APPLICATION NO. : 29/582827  
DATED : August 22, 2017  
INVENTOR(S) : Gen Ikeda et al.

Page 1 of 2

It is certified that error appears in the above-identified patent and that said Letters Patent is hereby corrected as shown below:

In the Drawings

Replace Fig. 7 with the following photographic sheet for Fig. 7 as shown on the attached sheet.

This certificate supersedes the Certificate of Correction issued July 3, 2018.

Signed and Sealed this  
Eighteenth Day of December, 2018

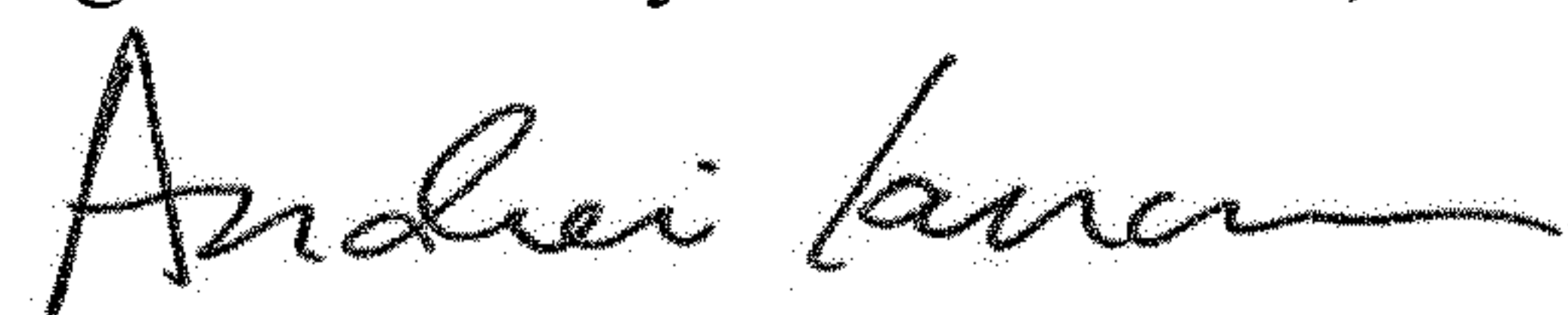

Andrei Iancu  
*Director of the United States Patent and Trademark Office*



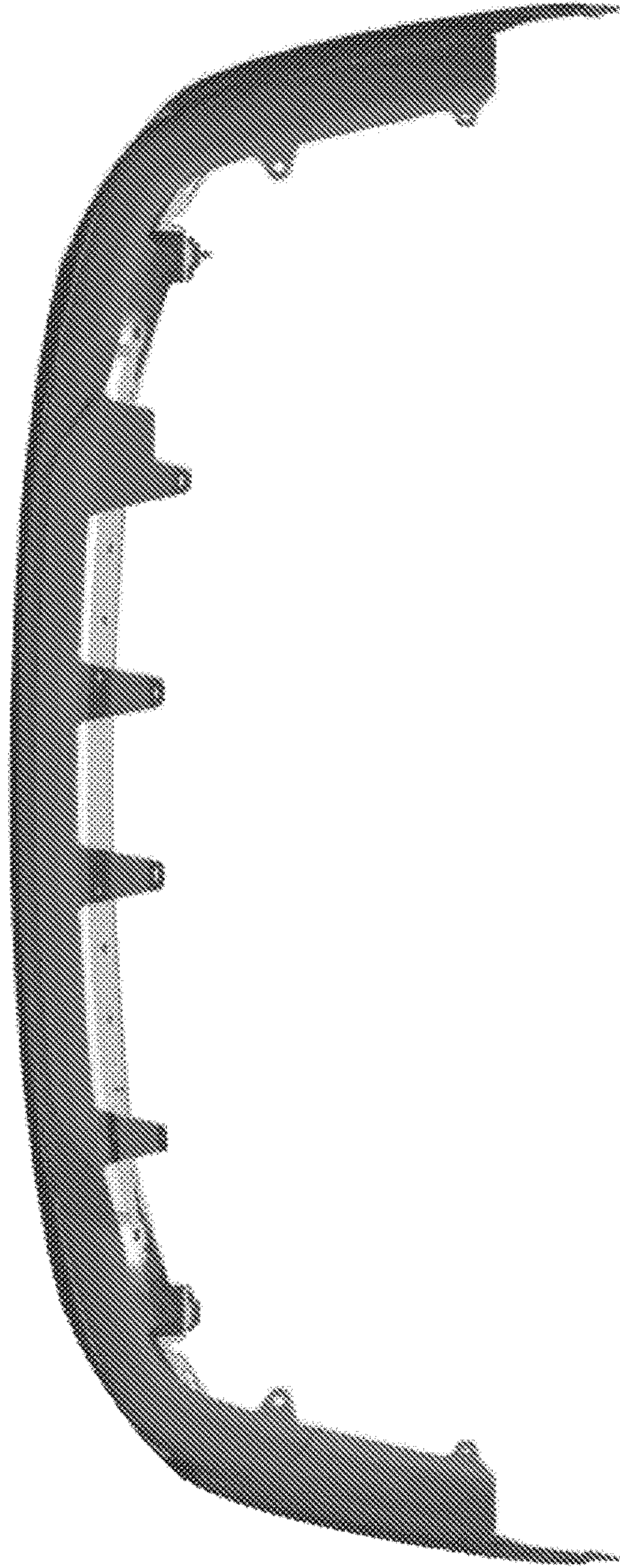

**FIG. 7**