



US00D795135S

(12) **United States Design Patent** (10) **Patent No.:** **US D795,135 S**
Davidson et al. (45) **Date of Patent:** **** Aug. 22, 2017**

(54) **AUTOMOBILE AND/OR REPLICA THEREOF**

FOREIGN PATENT DOCUMENTS

(71) Applicant: **HONDA MOTOR CO., LTD.**, Tokyo (JP)

JP D1328824 S 5/2008
JP D1446878 S 7/2012

(72) Inventors: **Benjamin R. Davidson**, Raymond, OH (US); **William R. Yex**, Raymond, OH (US)

OTHER PUBLICATIONS

Office Action dated Jun. 3, 2015, issued in counterpart Japanese Patent Application No. 2014-026678 (1 page).

(73) Assignee: **HONDA MOTOR CO., LTD.**, Tokyo (JP)

* cited by examiner

(**) Term: **15 Years**

Primary Examiner — Melody N Brown

(21) Appl. No.: **29/528,196**

(74) *Attorney, Agent, or Firm* — Westerman, Hattori, Daniels & Adrian, LLP

(22) Filed: **May 27, 2015**

(57) **CLAIM**

The ornamental design for an automobile and/or replica thereof, as shown and described.

(30) **Foreign Application Priority Data**

DESCRIPTION

Nov. 28, 2014 (JP) 2014-026678

(51) **LOC (10) Cl.** **12-08**

(52) **U.S. Cl.**
USPC **D12/88**; D12/92

(58) **Field of Classification Search**
USPC D12/86, 90-92, 88; D21/421, 433, 434; 296/181.1, 181.5
CPC B62D 35/00; B62D 25/00; B62D 25/06; B62D 33/00
See application file for complete search history.

FIG. 1 is a front view of an automobile and/or replica thereof showing my new design;
FIG. 2 is a rear view of the automobile and/or replica thereof;
FIG. 3 is a top plan view of the automobile and/or replica thereof;
FIG. 4 is a right side view of the automobile and/or replica thereof;
FIG. 5 is a left side view of the automobile and/or replica thereof;
FIG. 6 is a front perspective view of the automobile and/or replica thereof as seen from a right side; and,
FIG. 7 is a rear perspective view of the automobile and/or replica thereof as seen from the right side.
In the drawings, the broken lines form no part of the claimed design.

(56) **References Cited**

U.S. PATENT DOCUMENTS

D573,509 S 7/2008 Lukasak et al.
D692,349 S 10/2013 Ohhashi et al.
D731,928 S * 6/2015 Manzoni D12/92
D734,212 S * 7/2015 Stephenson D12/92
D734,213 S * 7/2015 Stephenson D12/92
D753,548 S * 4/2016 Gilles D12/88

1 Claim, 4 Drawing Sheets

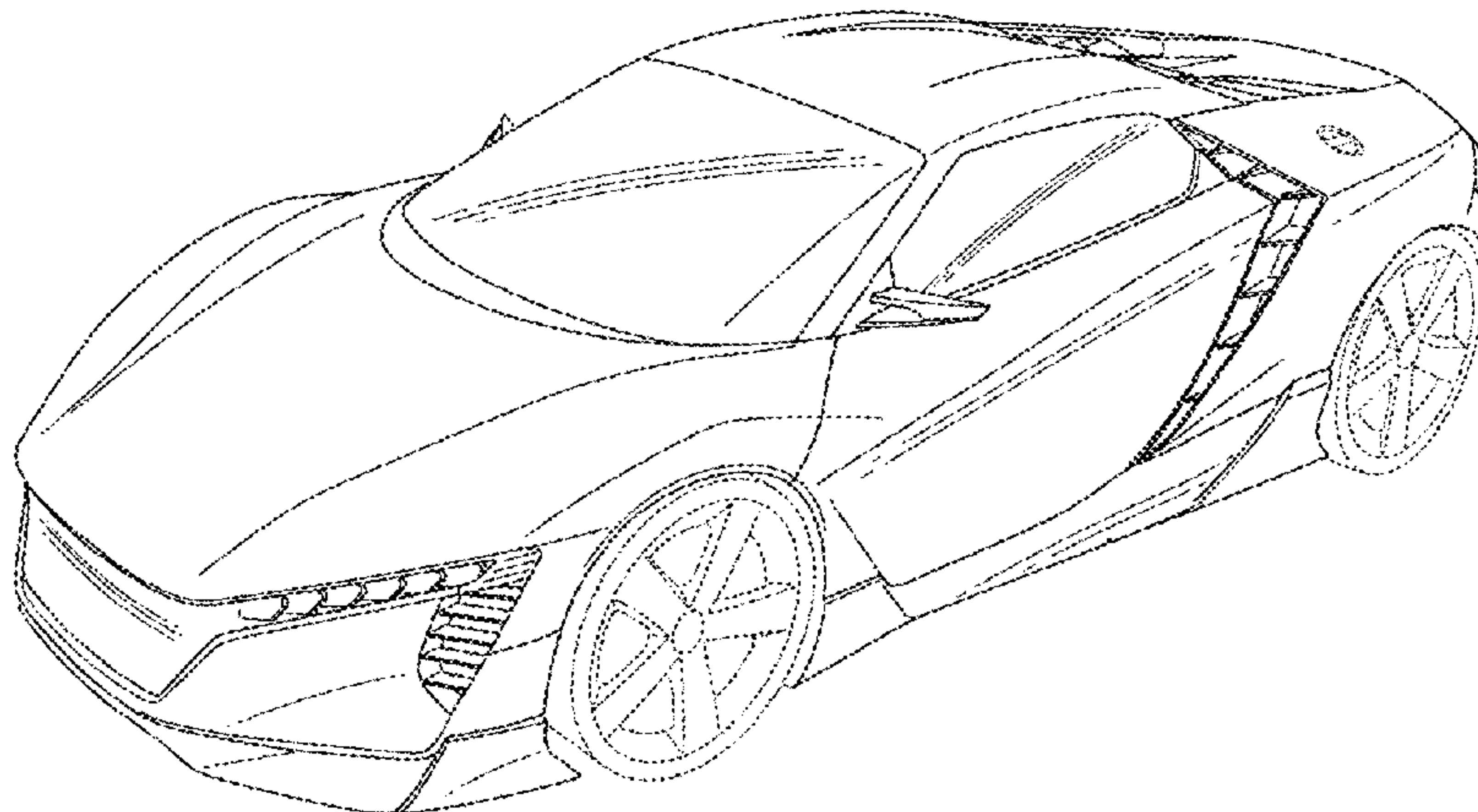

FIG.1

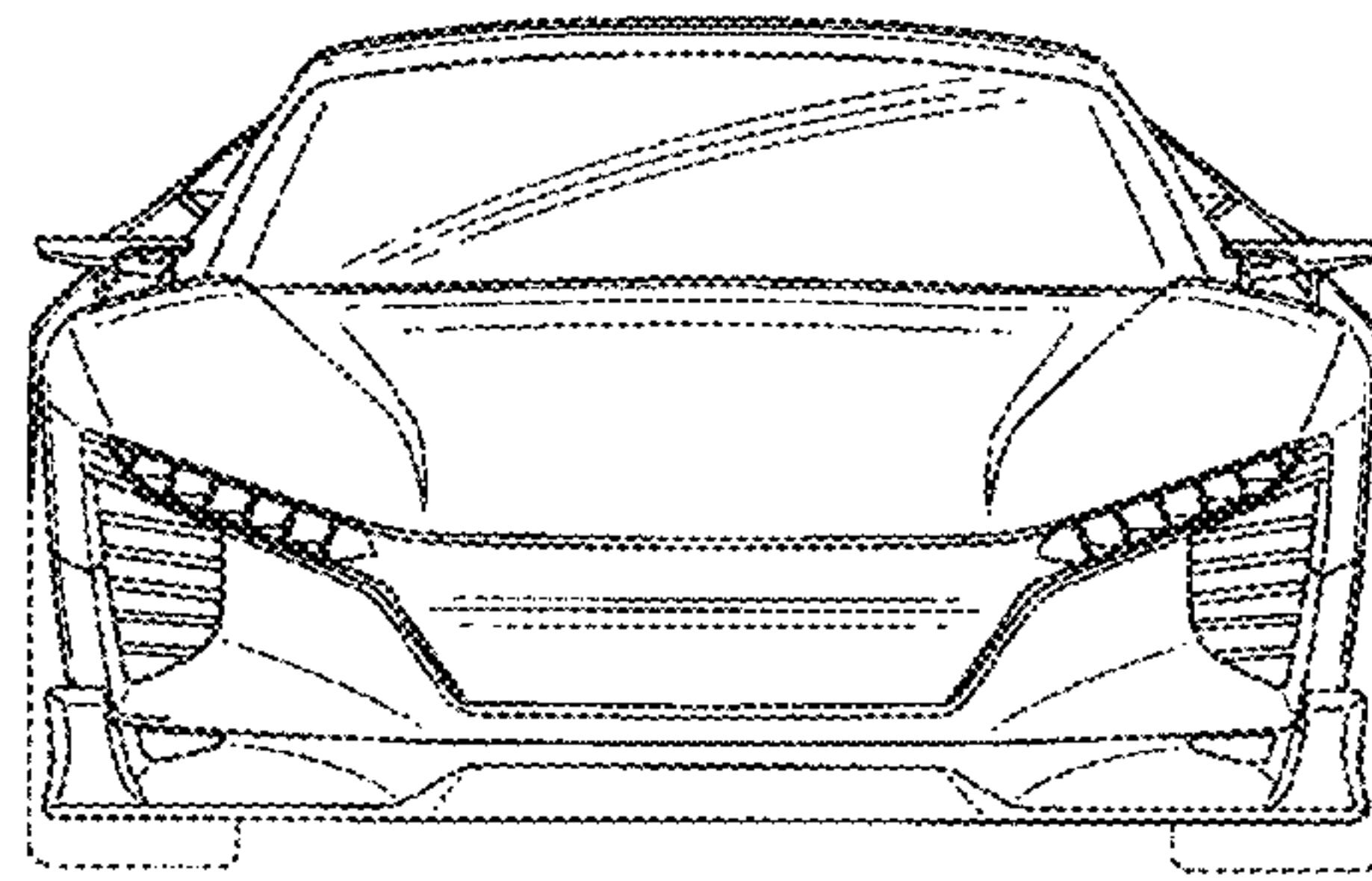

FIG.2

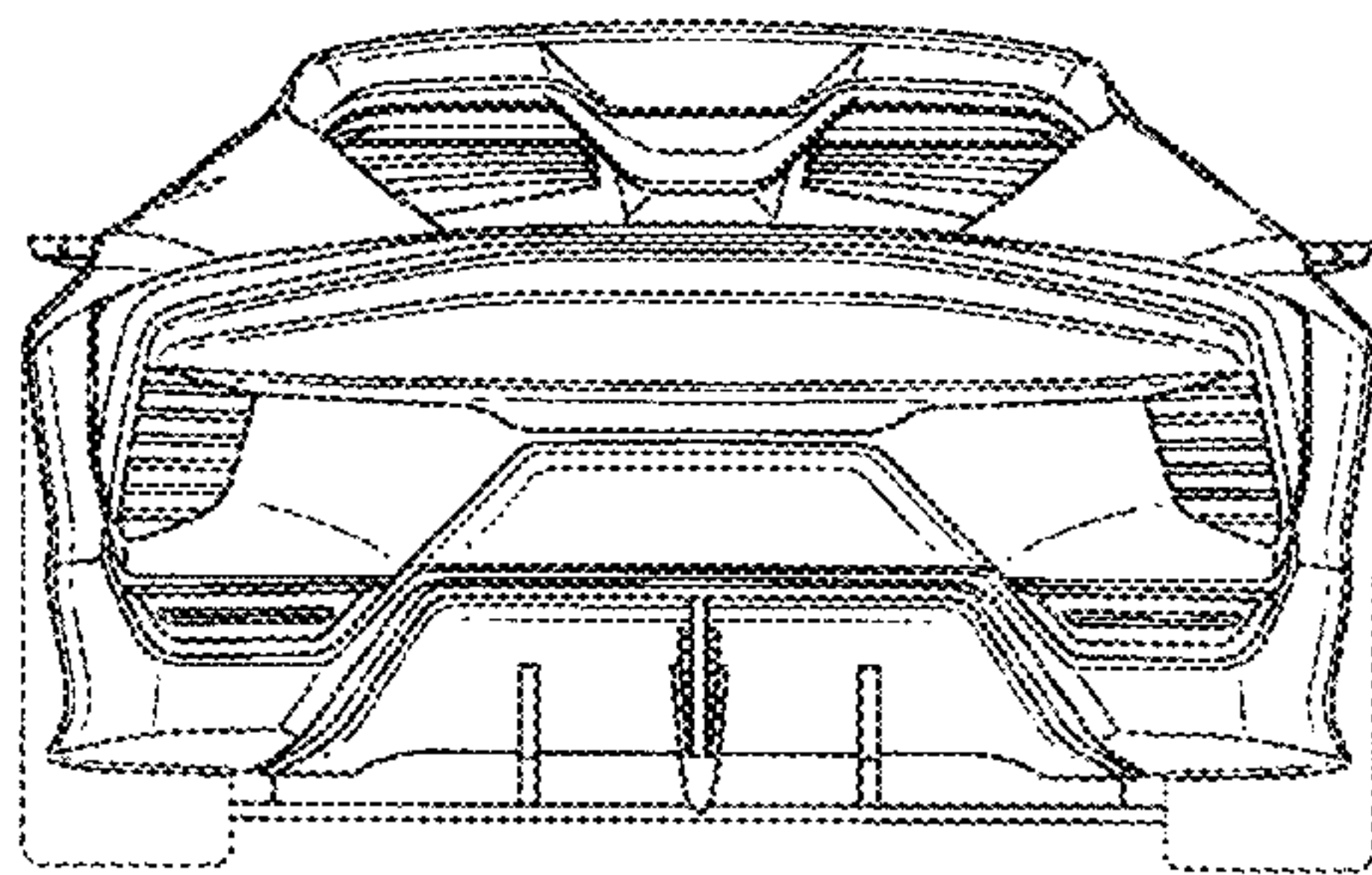

FIG.3

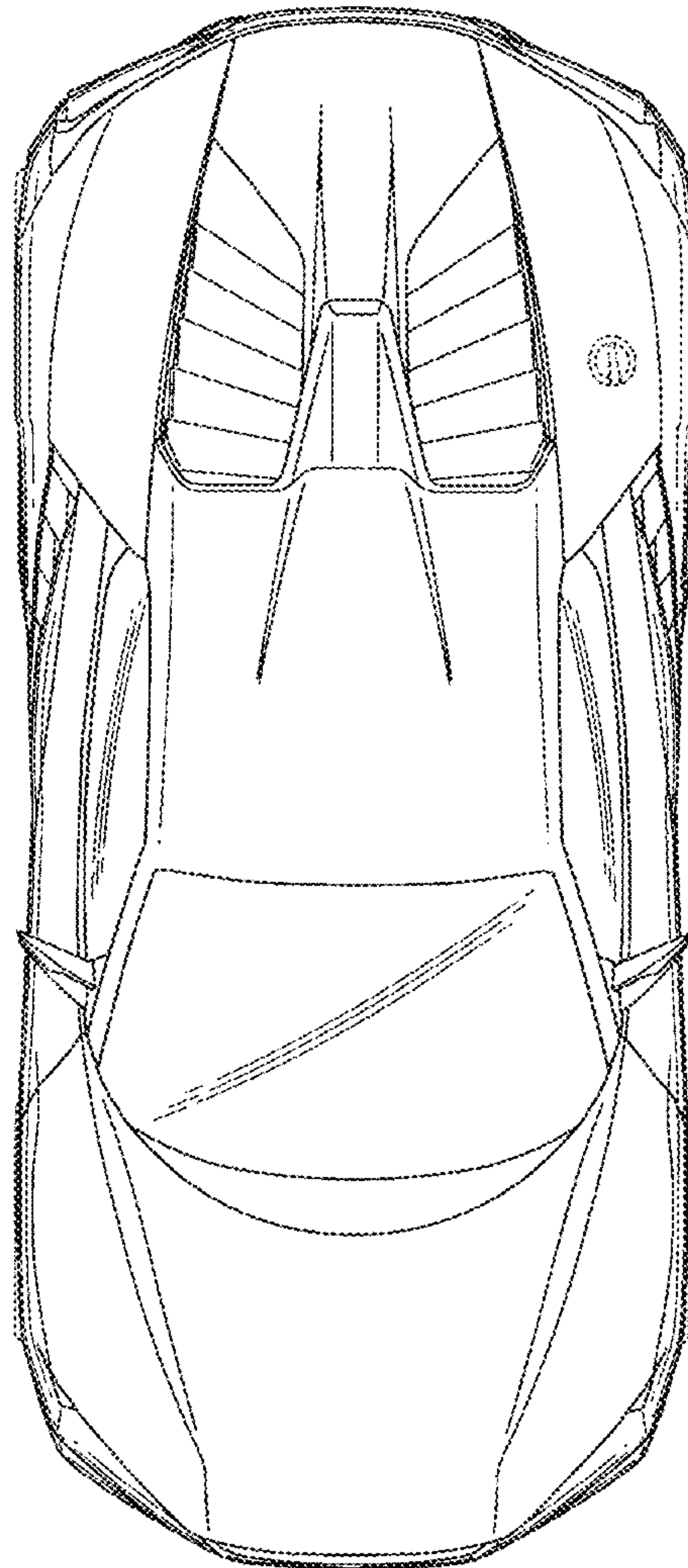

FIG.4

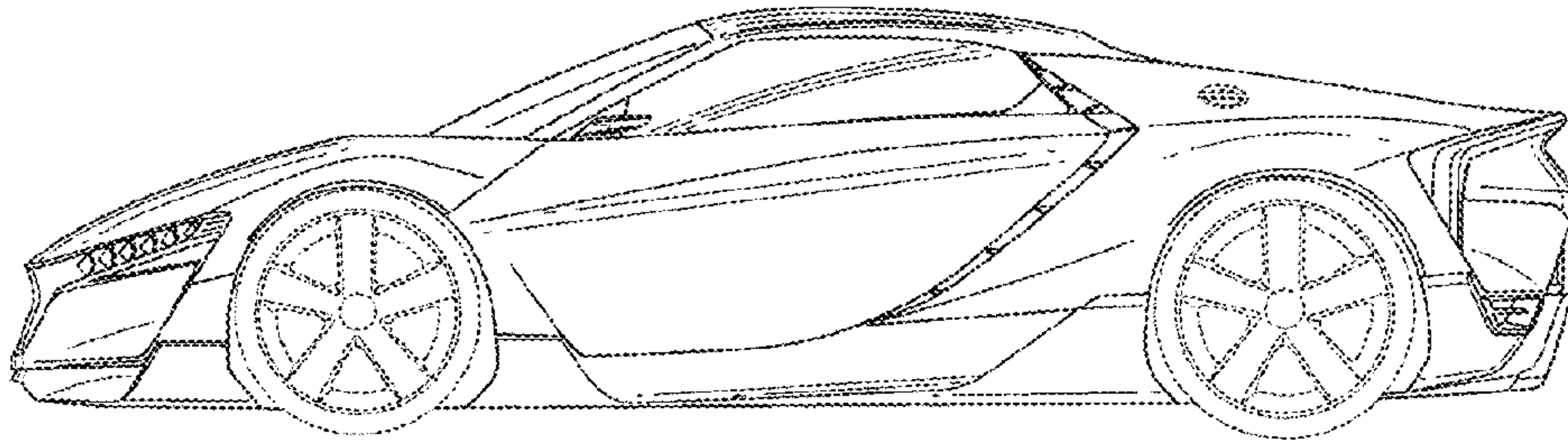

FIG.5

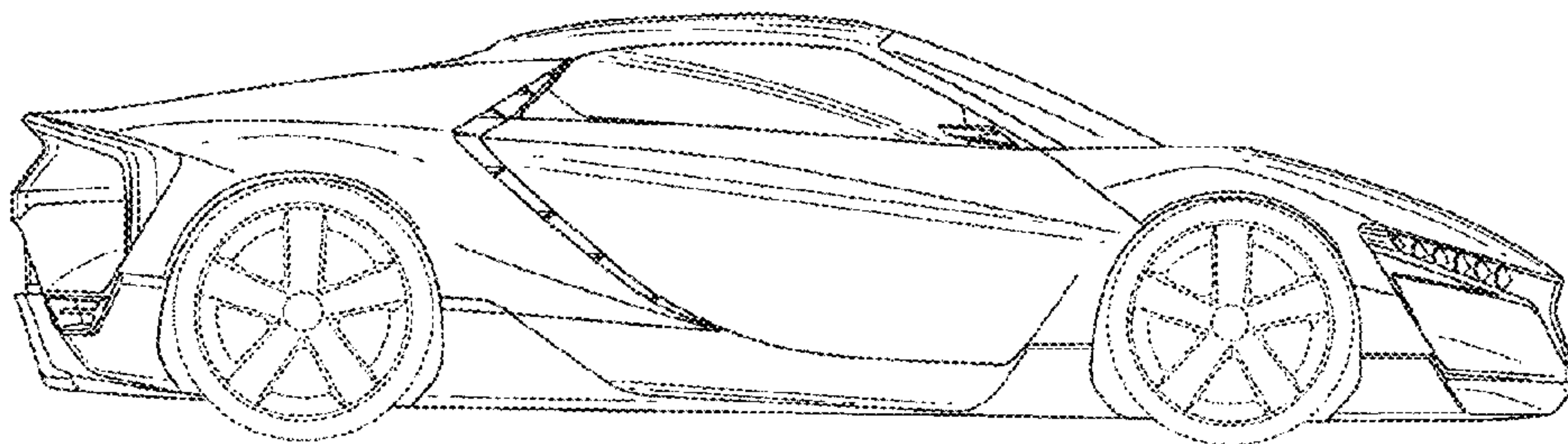

FIG.6

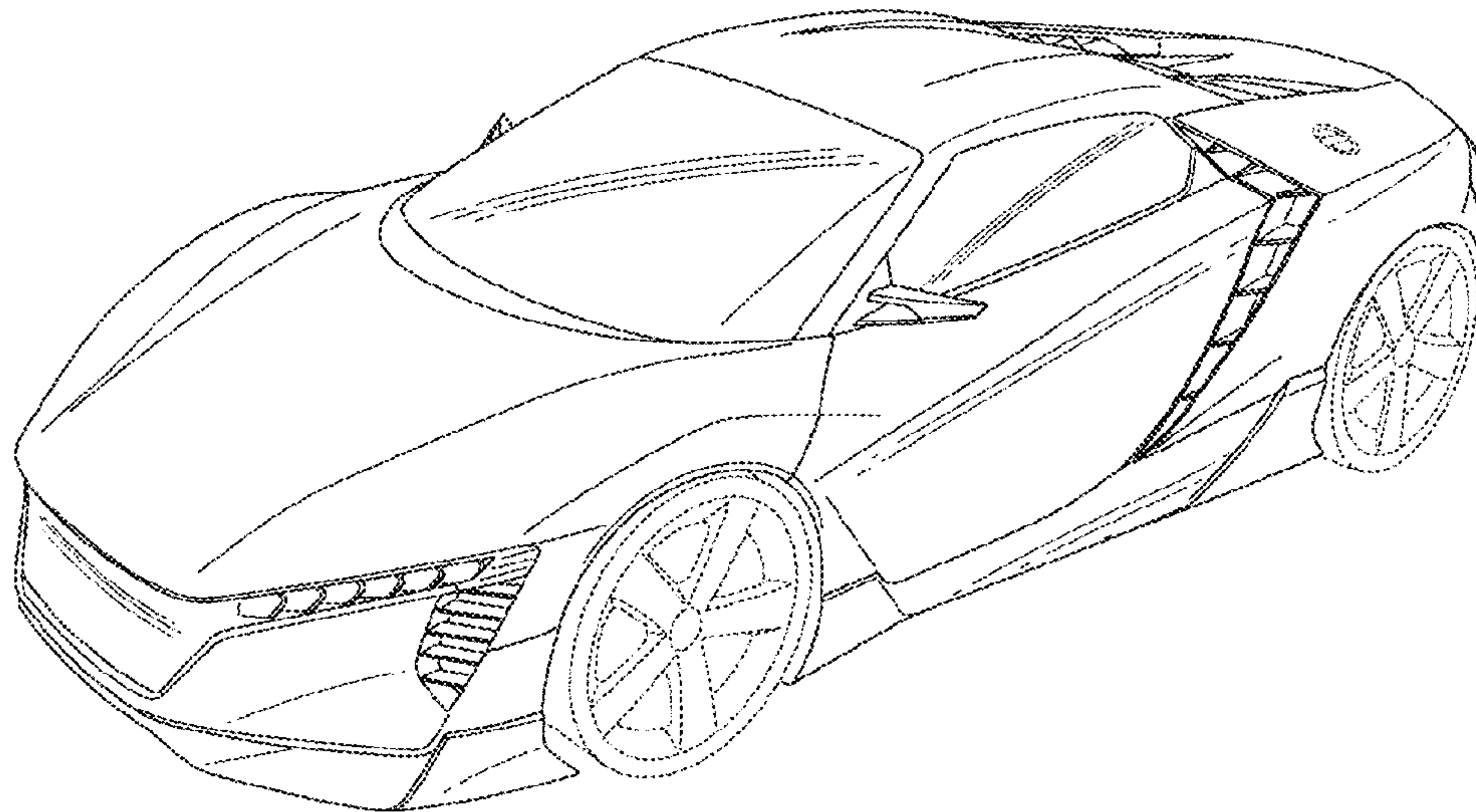

FIG.7

