



US00D794569S

(12) **United States Design Patent** (10) **Patent No.:** **US D794,569 S**
Giordano et al. (45) **Date of Patent:** **** Aug. 15, 2017**

(54) **CONNECTOR FOR AUTOMOTIVE POWER CORD KIT**

(71) Applicants: **Michael A. Giordano**, Rohnert Park, CA (US); **Sebastien Jame**, Sebastopol, CA (US)

(72) Inventors: **Michael A. Giordano**, Rohnert Park, CA (US); **Sebastien Jame**, Sebastopol, CA (US)

(73) Assignee: **J28 Design Inc.**, Cotati, CA (US)

(**) Term: **15 Years**

(21) Appl. No.: **29/564,181**

(22) Filed: **May 11, 2016**

(51) **LOC (10) Cl.** **13-03**

(52) **U.S. Cl.**
USPC **D13/133; D13/153**

(58) **Field of Classification Search**
USPC D13/103, 107, 110, 133, 146, 147, 151, D13/153, 154, 155, 144, 137.2, 138.1; D14/433, 435.1; D8/356; D23/262
CPC H01R 13/5845; H01R 13/72; H01R 31/06; H01R 24/00; H01R 24/28; H01R 12/00; H01B 11/1808; H01B 11/1839; H01B 11/1008; H01B 7/04; H01B 7/0266; H01B 7/08; H01B 7/065; H01B 12/08
See application file for complete search history.

(56) **References Cited**

U.S. PATENT DOCUMENTS

D335,535 S * 5/1993 Arioka D24/112
D413,301 S * 8/1999 Goto D13/133
D461,827 S * 8/2002 Koebbe D15/7

D480,030 S * 9/2003 Gilli D12/194
D578,966 S * 10/2008 Grimm D13/153
D582,849 S * 12/2008 Kuo D13/133
D588,992 S * 3/2009 Zhao D13/133
D624,019 S * 9/2010 Victor D13/133
D652,059 S * 1/2012 Sato D15/9
D698,627 S * 2/2014 Chance D13/156
D706,117 S * 6/2014 Toimil D13/154
D710,800 S * 8/2014 Chen D13/110
D721,654 S * 1/2015 Leem D13/146
D753,065 S * 4/2016 Corona D13/146
D755,130 S * 5/2016 Toimil D13/156
D762,588 S * 8/2016 Chin D13/155
2013/0175081 A1 * 7/2013 Watanabe H01B 11/18
174/363

* cited by examiner

Primary Examiner — Rosemary K Tarcza

Assistant Examiner — Christy Nemeth

(74) *Attorney, Agent, or Firm* — Bay Area Technology Law Group PC

(57) **CLAIM**

The ornamental design for an connector for automotive power cord kit, as shown and described.

DESCRIPTION

FIG. 1 is a perspective view of a connector for automotive power cord kit showing our new design;
FIG. 2 is a side view thereof;
FIG. 3 is a top view thereof;
FIG. 4 is a front view thereof; and,
FIG. 5 is a rear view thereof.
The broken lines in the drawings are for the purpose of illustrating environmental subject matter that forms no part of the claimed design.

1 Claim, 2 Drawing Sheets

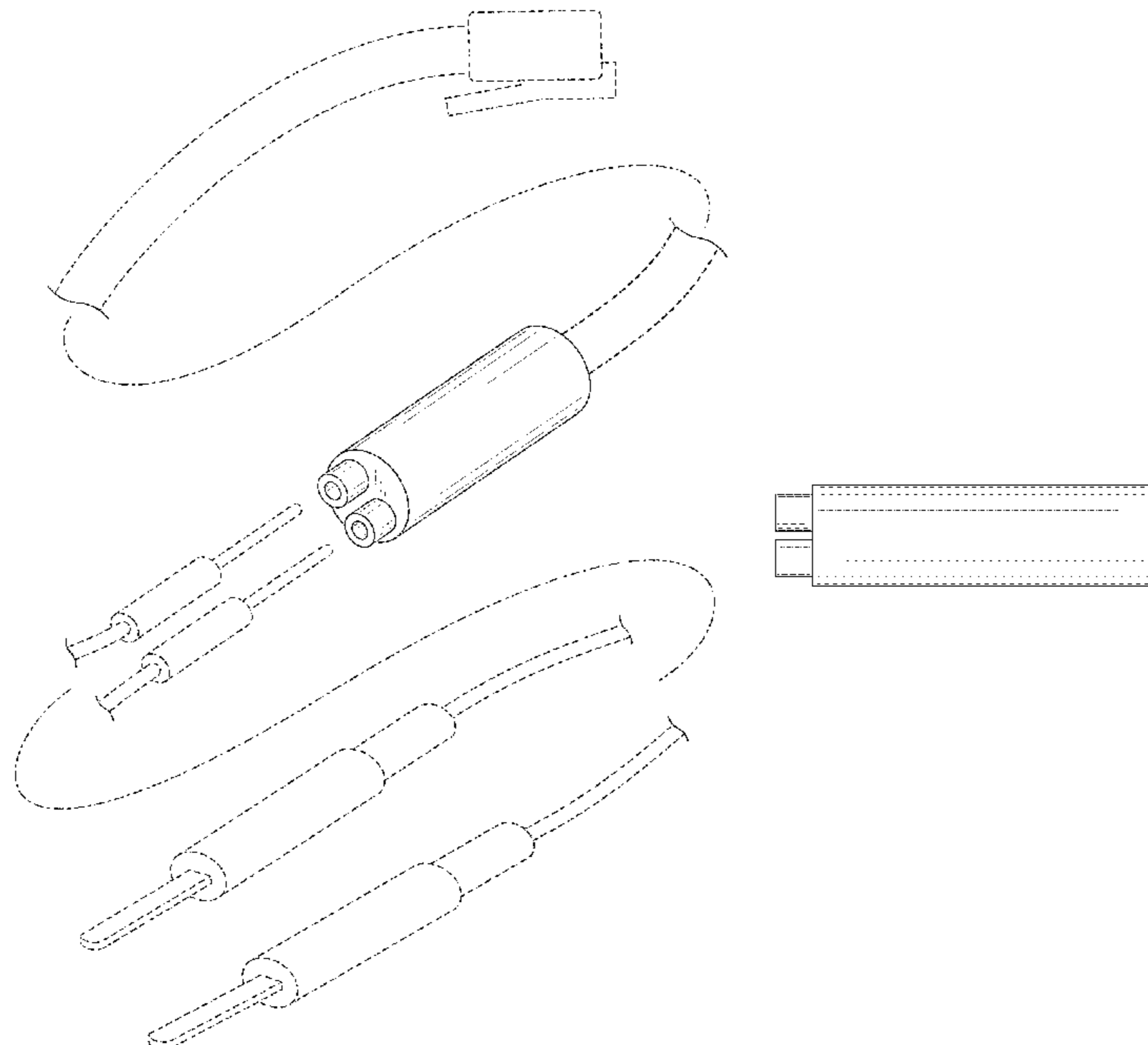

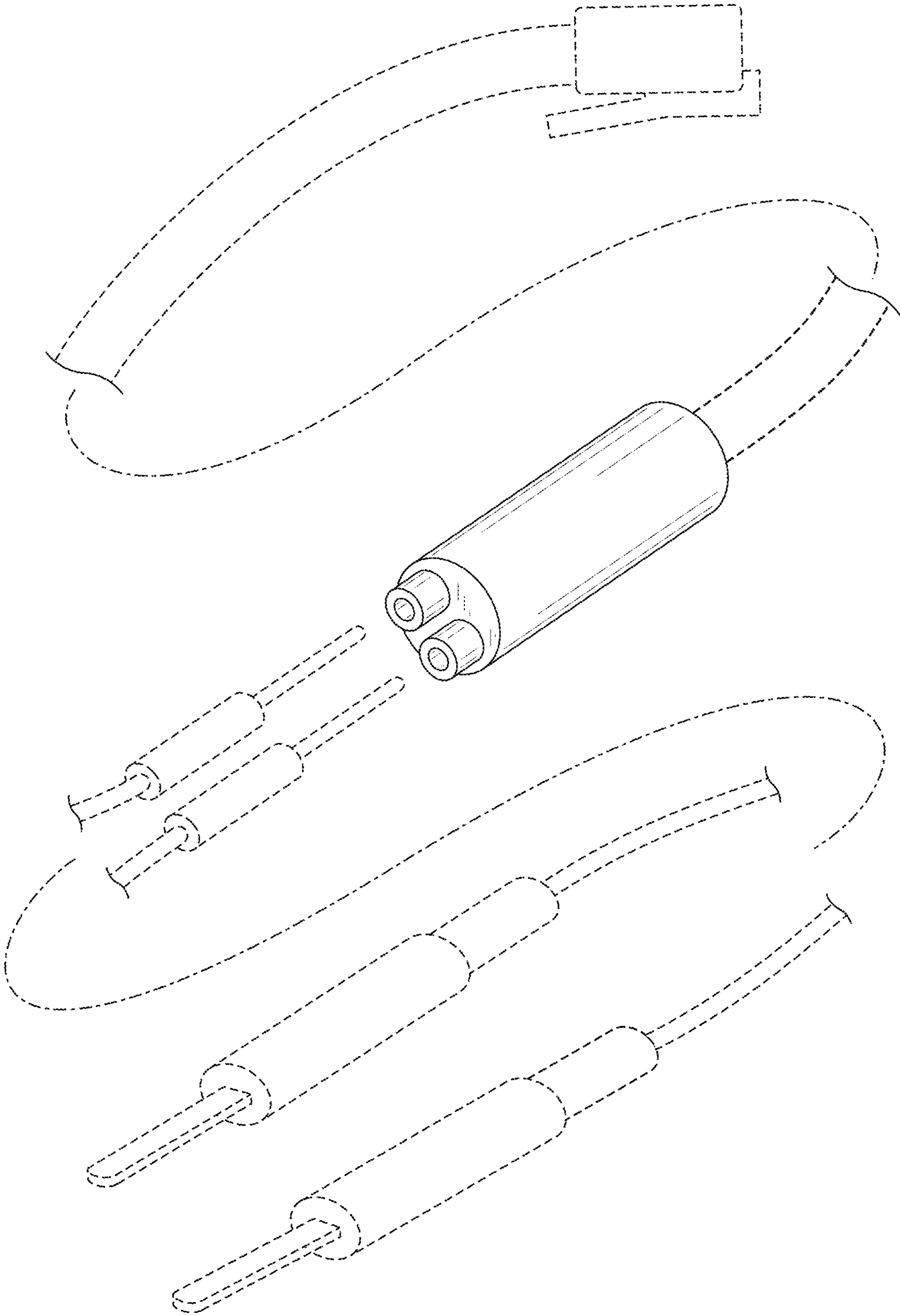

FIG. 1

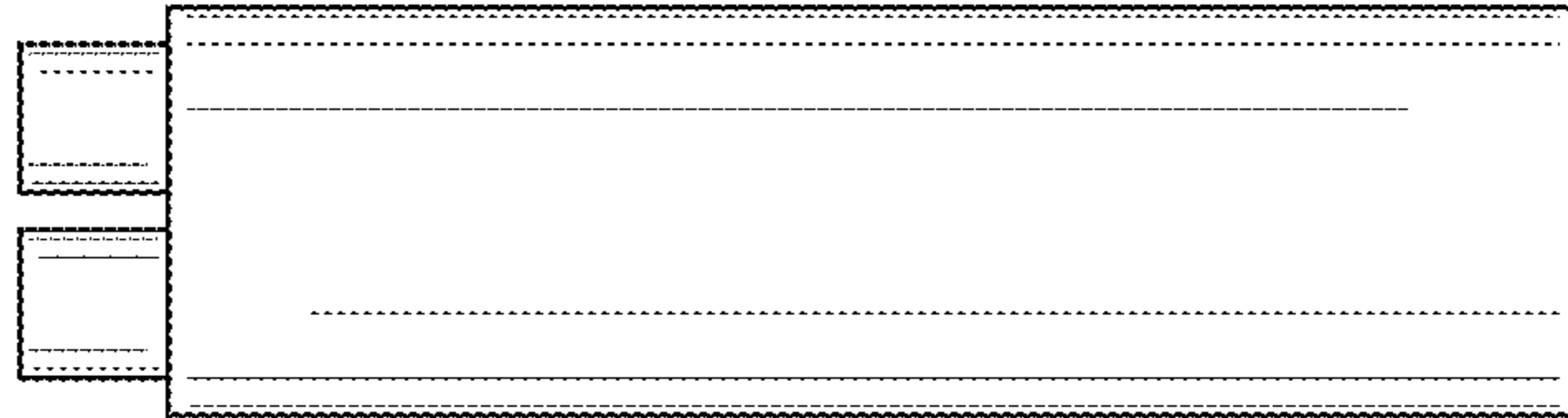

FIG. 2

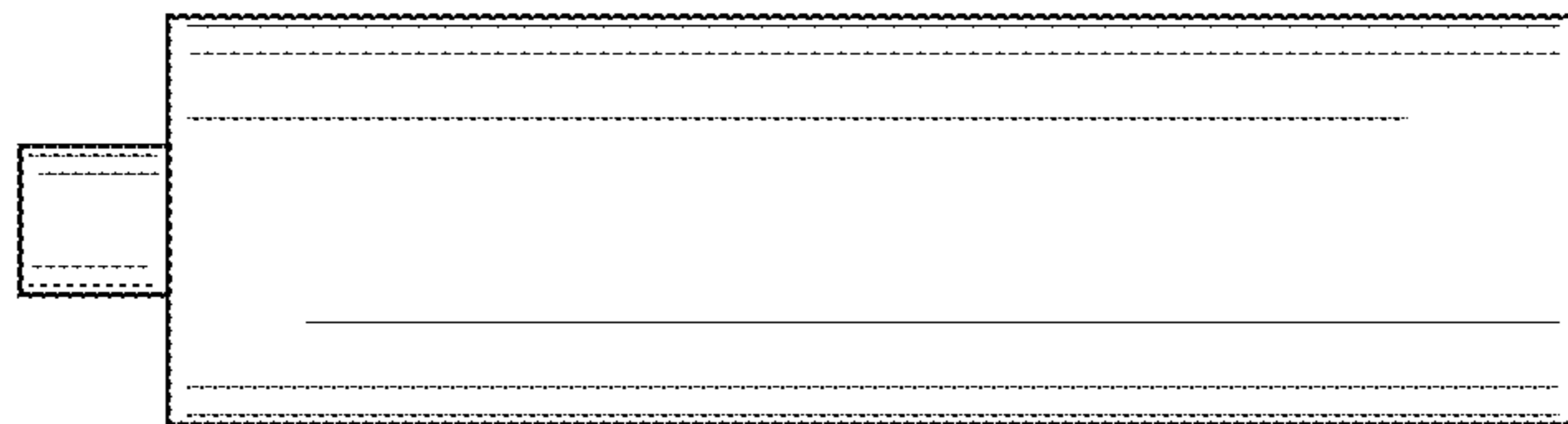

FIG. 3

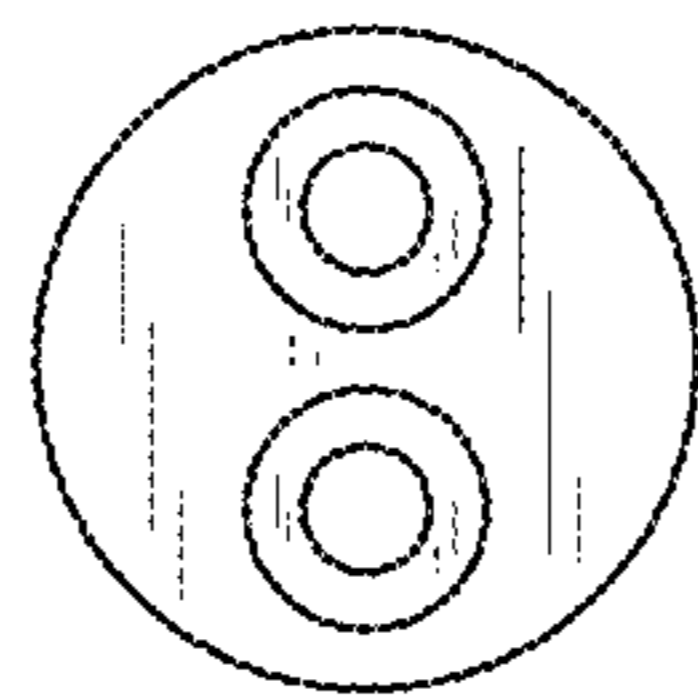

FIG. 4

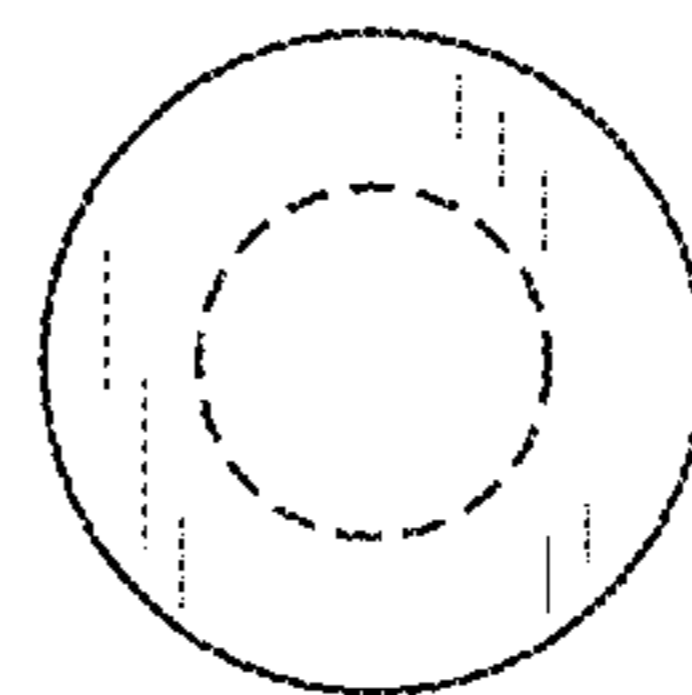

FIG. 5