



US00D794509S

(12) **United States Design Patent** (10) **Patent No.:** **US D794,509 S**
Hurtado Salas (45) **Date of Patent:** **** Aug. 15, 2017**

(54) **AUTOMOBILE**

- (71) Applicant: **JOFEMAR, S. A.**, Peralta (Navarra) (ES)
- (72) Inventor: **Francisco Javier Hurtado Salas**, Granada (ES)
- (73) Assignee: **Francisco Javier Hurtado Salas**, Peralta (ES)
- (**) Term: **14 Years**
- (21) Appl. No.: **29/503,609**
- (22) Filed: **Sep. 29, 2014**
- (51) **LOC (10) Cl.** **12-08**
- (52) **U.S. Cl.**
USPC **D12/91**
- (58) **Field of Classification Search**
USPC D12/86, 90, 91, 92, 163, 169, 171, 183,
D12/196, 216; 293/102, 113, 115, 117,
293/120; 296/180.1, 180.2, 181.1, 181.5
CPC B60L 2200/24
See application file for complete search history.

(56) **References Cited**

U.S. PATENT DOCUMENTS

D385,220	S	*	10/1997	Warkuss	D12/90
D411,814	S	*	7/1999	Chibuka	D12/90
D422,940	S	*	4/2000	Hanagan	D12/85
D432,050	S	*	10/2000	Ligier	D12/91
D457,835	S	*	5/2002	Iso	D12/91
D466,445	S	*	12/2002	Stolz	D12/91
D615,905	S	*	5/2010	Arnell	D12/91
D619,046	S	*	7/2010	Liu	D12/90
D626,032	S	*	10/2010	Starr	D12/85
D671,452	S	*	11/2012	Fernandez Isoird	D12/86
D700,104	S	*	2/2014	Malachowski	D12/90
D742,281	S	*	11/2015	Ishii	D12/91
D756,848	S	*	5/2016	Toriyama	D12/91

OTHER PUBLICATIONS

- “Jofemar Velex, Electrico made in Navarra”. Found online Jun. 20, 2016 at es.autoblog.com. Page dated Dec. 11, 2014. Retrieved from <http://es.autoblog.com/2014/12/11/jofemar-velex-electrico-made-in-navarra/>.*
- “Mazda Unveils the All-New 2014 Mazda 3”. Found online Jun. 20, 2016 at wheels.blogs.nytimes.com. Page dated Jun. 26, 2013. Retrieved from http://wheels.blogs.nytimes.com/2013/06/26/mazda-unveils-the-all-new-2014-mazda-3/?_r=1.*
- “Electric Car Popularity—Reasons People Prefer Electric Cars to Gas Cars”. Found online Jun. 20, 2016 at greenliving4live.com. Page dated Jul. 1, 2013. Retrieved from <http://greenliving4live.com/2013/07/electric-car-popularity-reasons-people-prefer-electric-cars-to-gas-cars/>.*
- “Renault Partners with L’Oreal for Zoe Z.E. Electric Concept Vehicle”. Found online Jun. 20, 2016 at psipunk.com. Page dated Nov. 16, 2009. Retrieved from <http://web.archive.org/web/20091116020425/http://psipunk.com/renault-partners-with-l’oreal-for-zoe-ze-electric-concept-vehicle/>.*

* cited by examiner

Primary Examiner — Robert M Spear
Assistant Examiner — Kendra L Hamilton
(74) *Attorney, Agent, or Firm* — Adam K. Sacharoff;
Much Selist, P.C.

(57) **CLAIM**

The ornamental design for an automobile, as shown and described.

DESCRIPTION

FIG. 1 is a front right side perspective view of an automobile in accordance with the invention;
FIG. 2 is a rear right side perspective view of FIG. 1;
FIG. 3 is a rear view of FIG. 1;
FIG. 4 is a right side elevational view of FIG. 1;
FIG. 5 is a front elevational view of FIG. 1; and,
FIG. 6 is a top plan view of FIG. 1.

1 Claim, 6 Drawing Sheets

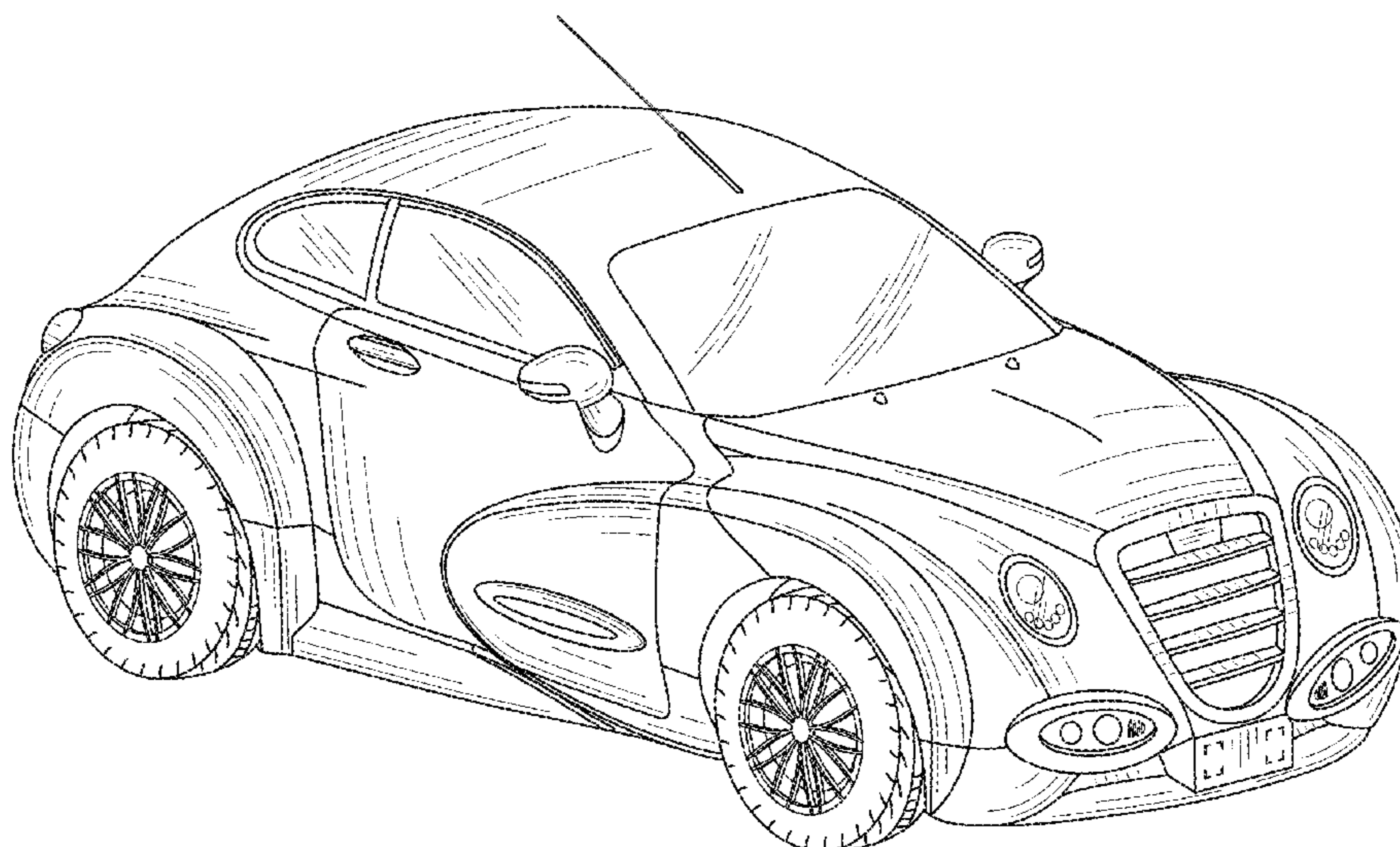

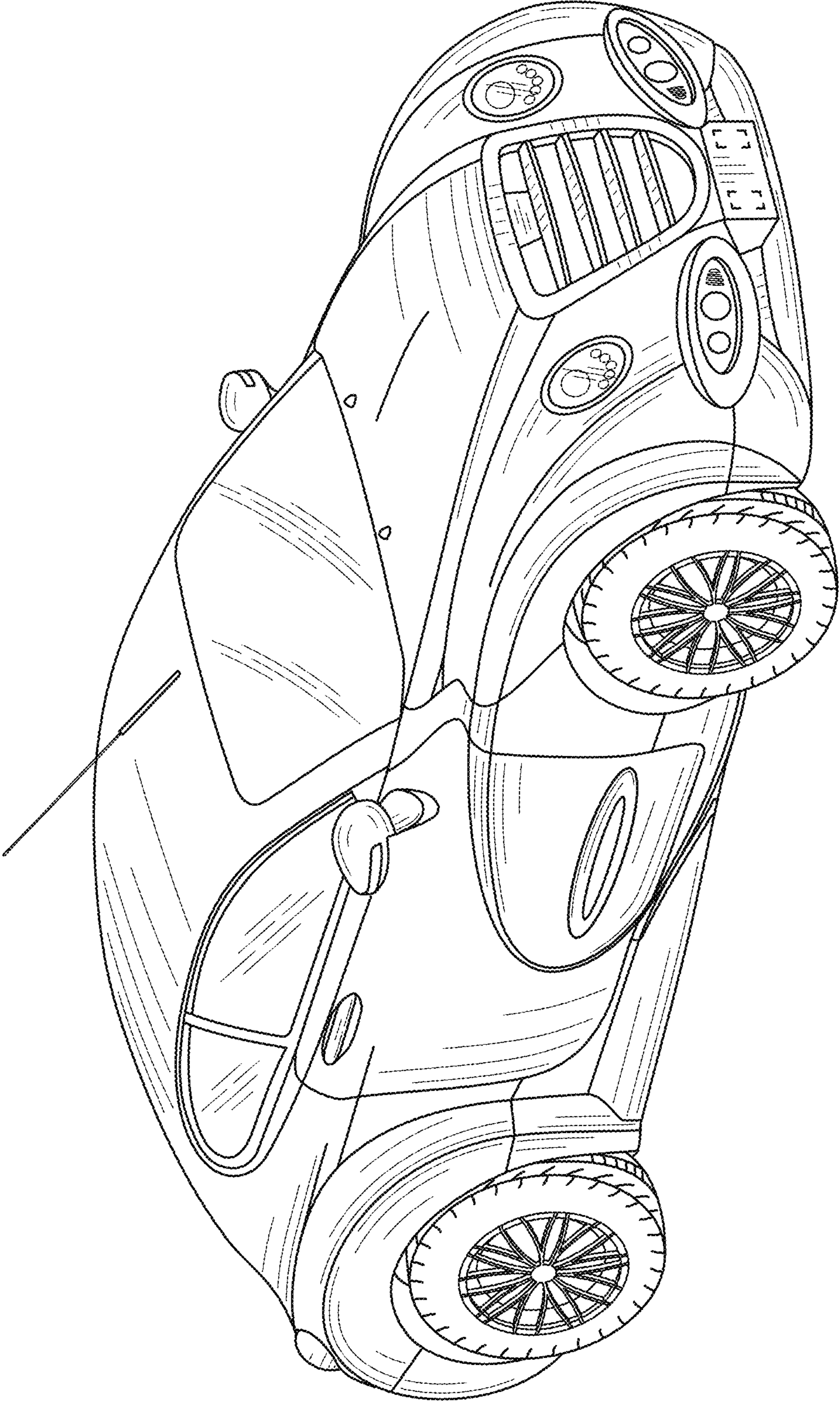

FIG. 1

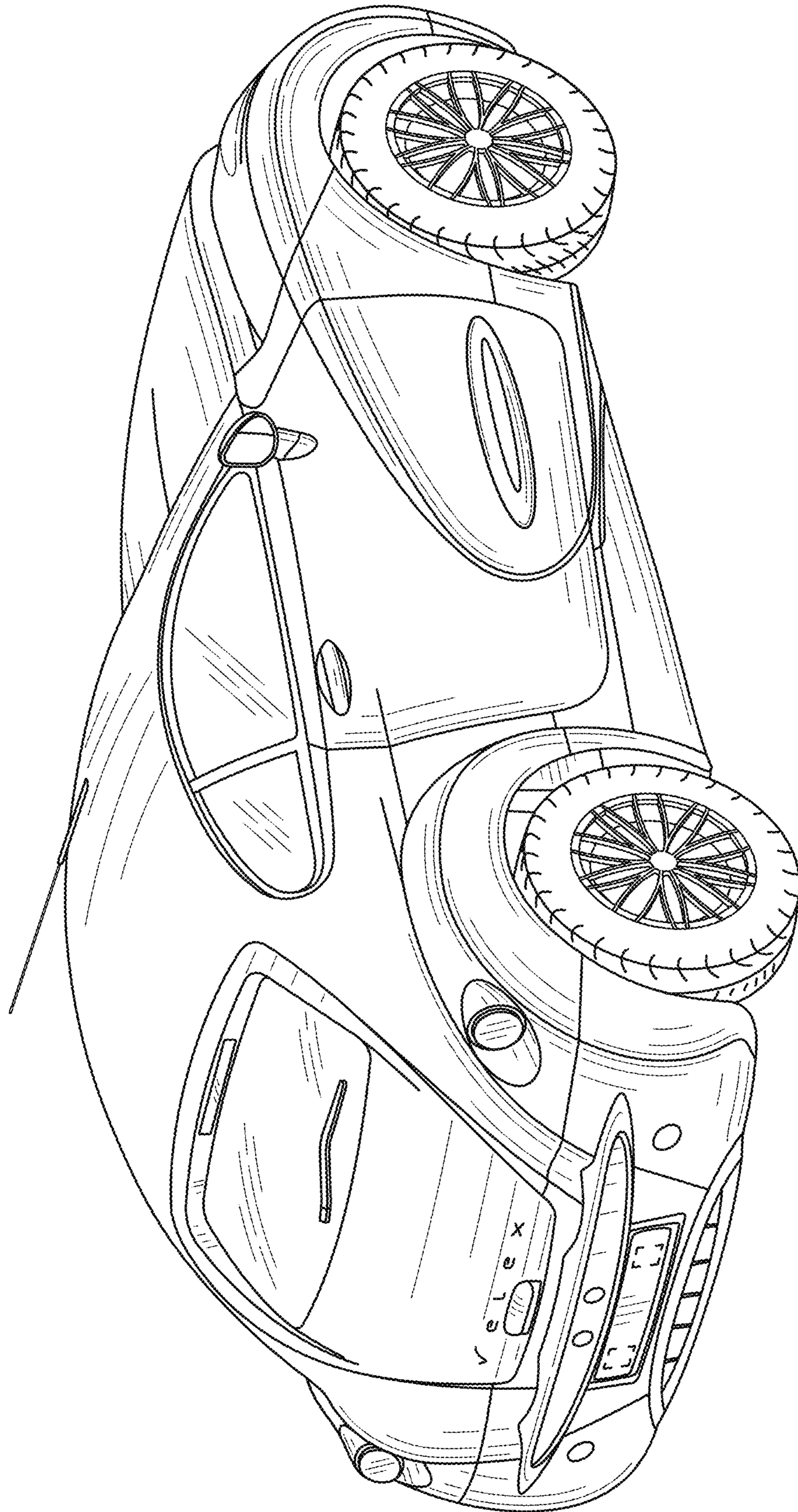

FIG. 2

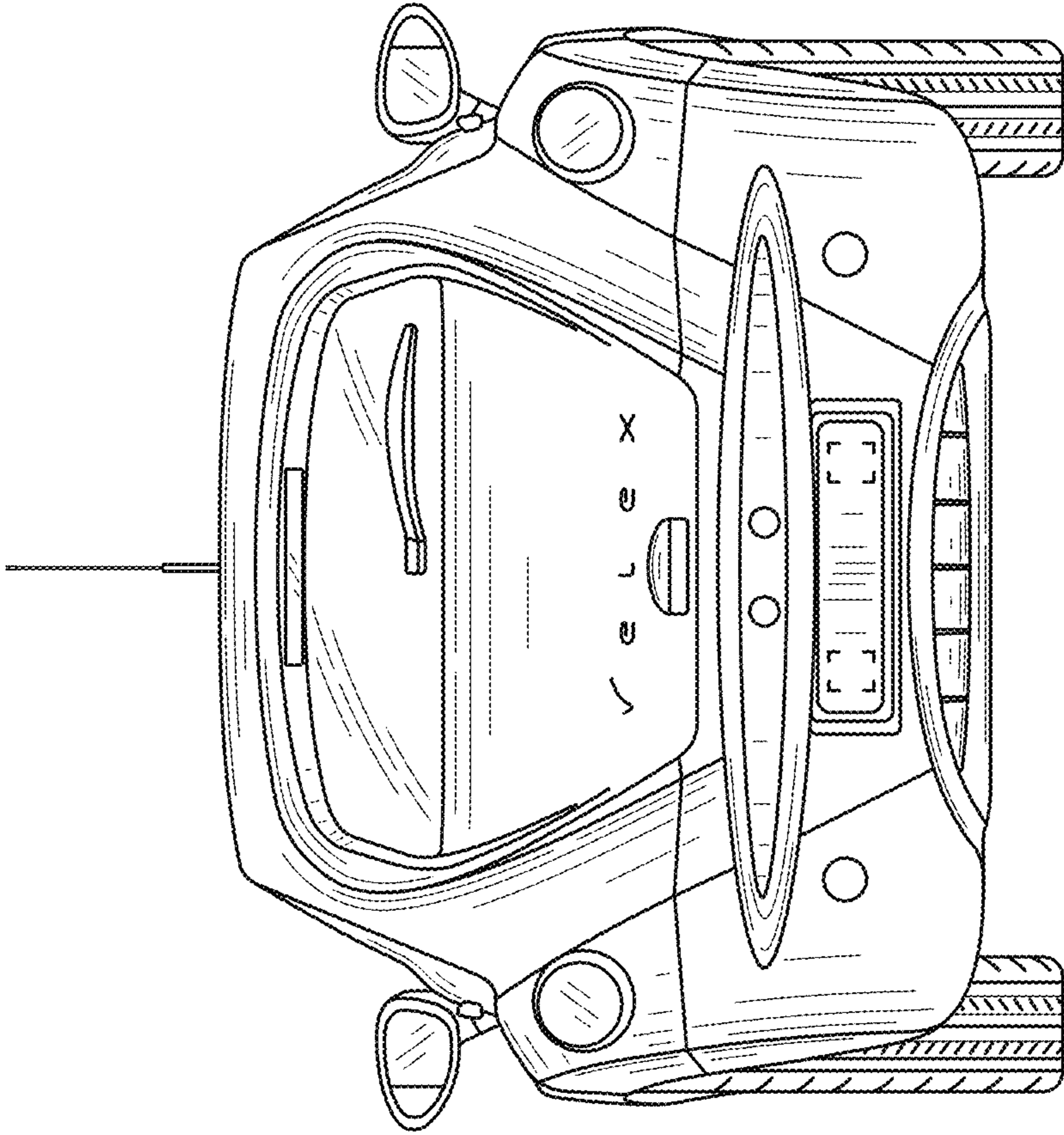

FIG. 3

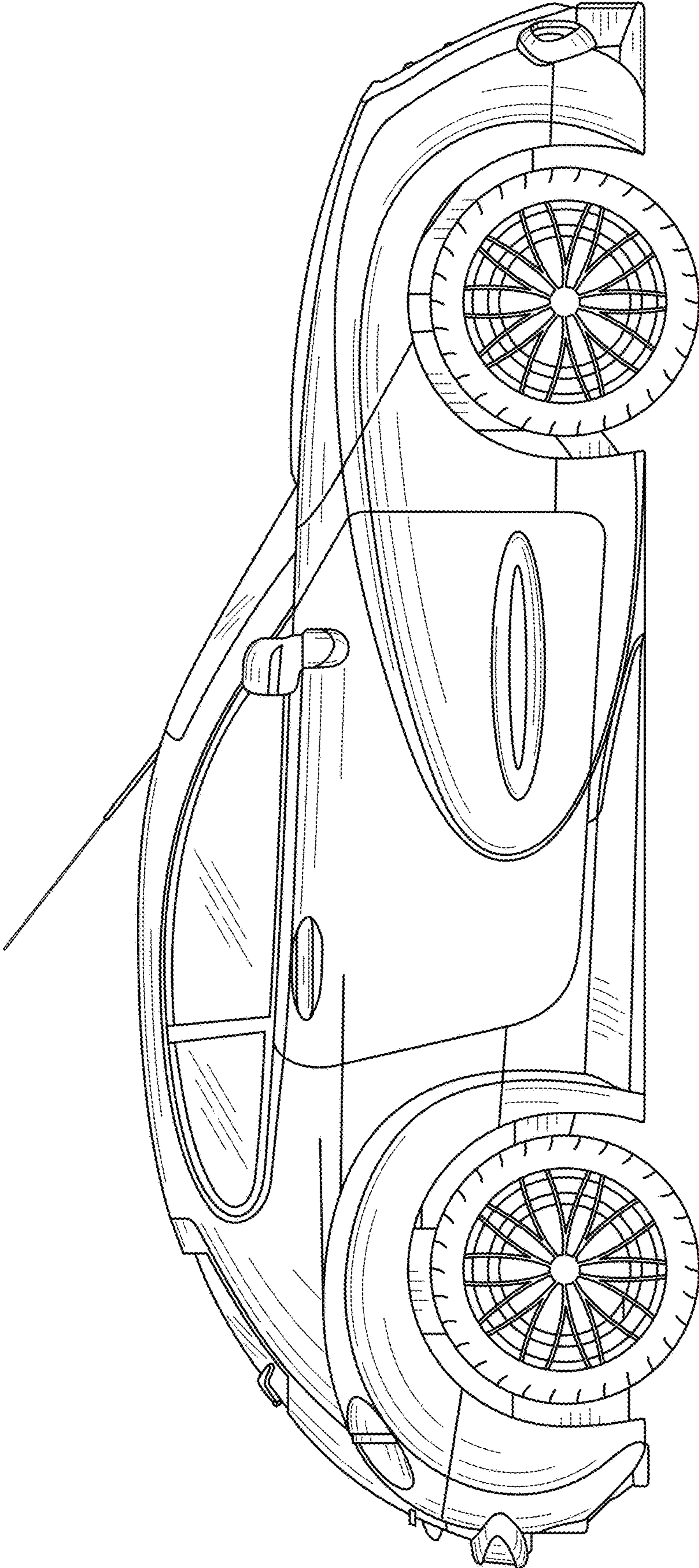

FIG. 4

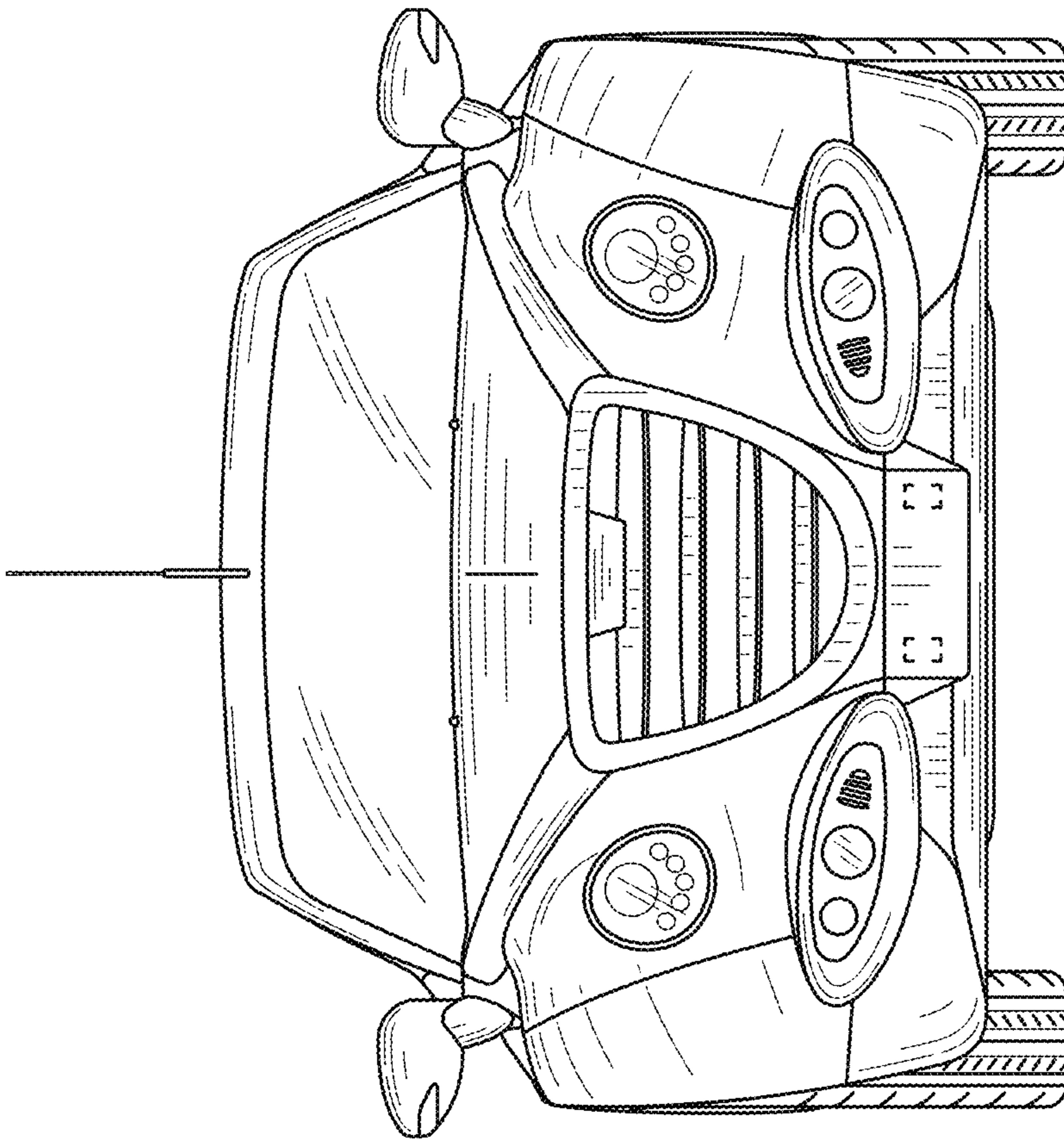

FIG. 5

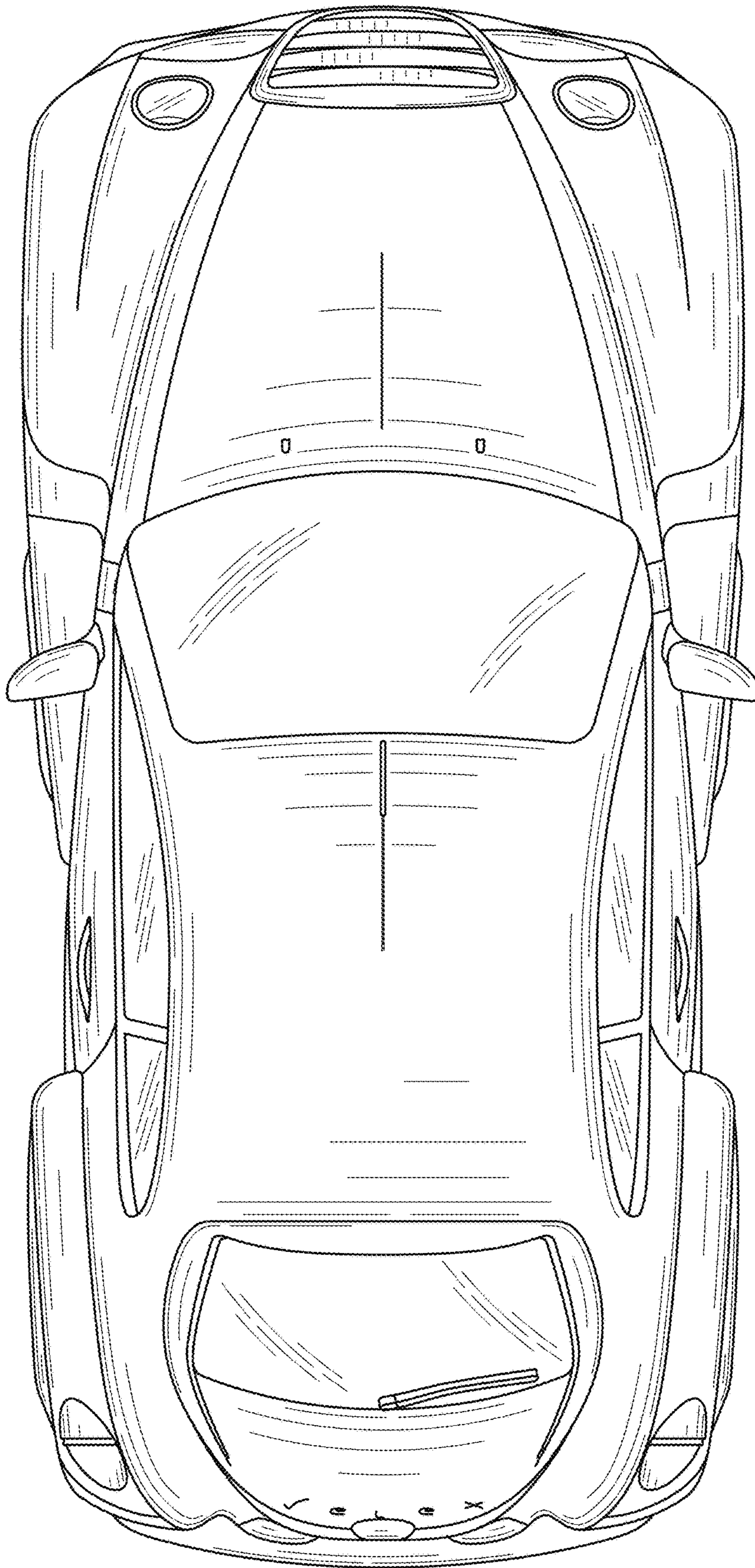

FIG. 6