

US00D794327S

(12) **United States Design Patent**
Venturini Fendi

(10) **Patent No.:** **US D794,327 S**

(45) **Date of Patent:** **** Aug. 15, 2017**

(54) **HANDBAG**

(71) Applicant: **Fendi Adele S.R.L.**, Rome (IT)

(72) Inventor: **Maria Silvia Venturini Fendi**, Rome (IT)

(73) Assignee: **FENDI ADELE S.R.L.**, Rome (IT)

(**) Term: **15 Years**

(21) Appl. No.: **29/564,466**

(22) Filed: **May 13, 2016**

(30) **Foreign Application Priority Data**

Apr. 22, 2016 (EM) 003082205-0001

(51) **LOC (10) Cl.** **03-01**

(52) **U.S. Cl.**
USPC **D3/245**

(58) **Field of Classification Search**
USPC D3/232-233, 240-243, 245-246
CPC A45C 1/024; A45C 3/06
See application file for complete search history.

(56) **References Cited**

U.S. PATENT DOCUMENTS

D222,951 S * 2/1972 Stringer 383/38
D650,169 S * 12/2011 Klifa D3/245

D653,849 S * 2/2012 Jariwala D3/232
D659,996 S * 5/2012 Fang D3/232
D698,548 S * 2/2014 Jacobs D3/245
D753,914 S * 4/2016 Van Migem D3/232
D756,115 S * 5/2016 Slimane D3/245
D761,018 S * 7/2016 Gamble D3/245
D767,887 S * 10/2016 Kim D3/245
D770,177 S * 11/2016 Guyon D3/245

* cited by examiner

Primary Examiner — Holly Baynham

(74) *Attorney, Agent, or Firm* — Lucas & Mercanti, LLP

(57) **CLAIM**

The ornamental design for a handbag, as shown and described.

DESCRIPTION

FIG. 1 is a perspective view of a handbag;
FIG. 2 is a rear view thereof;
FIG. 3 is a front view thereof;
FIG. 4 is a top view thereof;
FIG. 5 is a bottom view thereof;
FIG. 6 is a right side view thereof; and,
FIG. 7 is a left side view thereof.
The broken lines showing stitching are part of the claimed design.

1 Claim, 7 Drawing Sheets

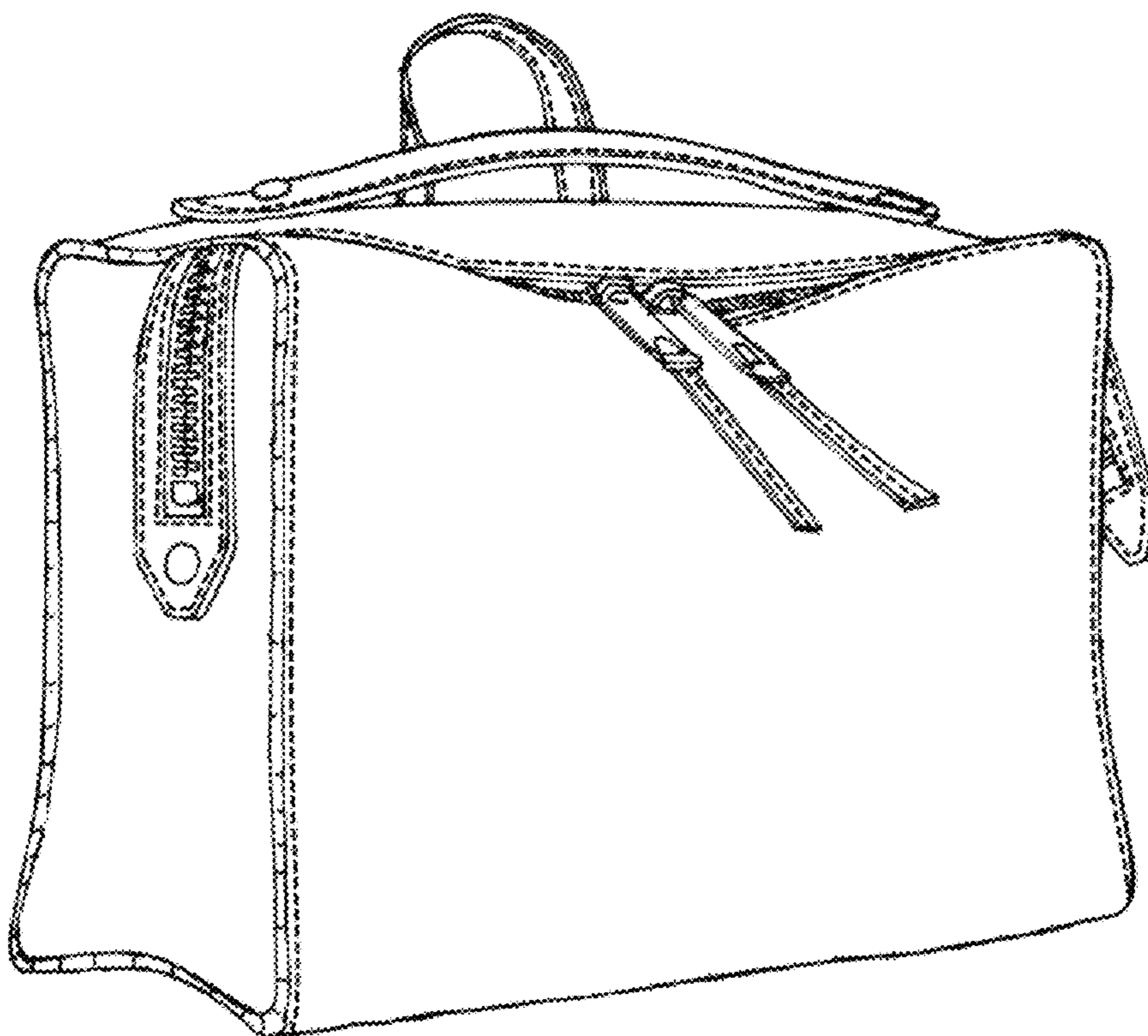

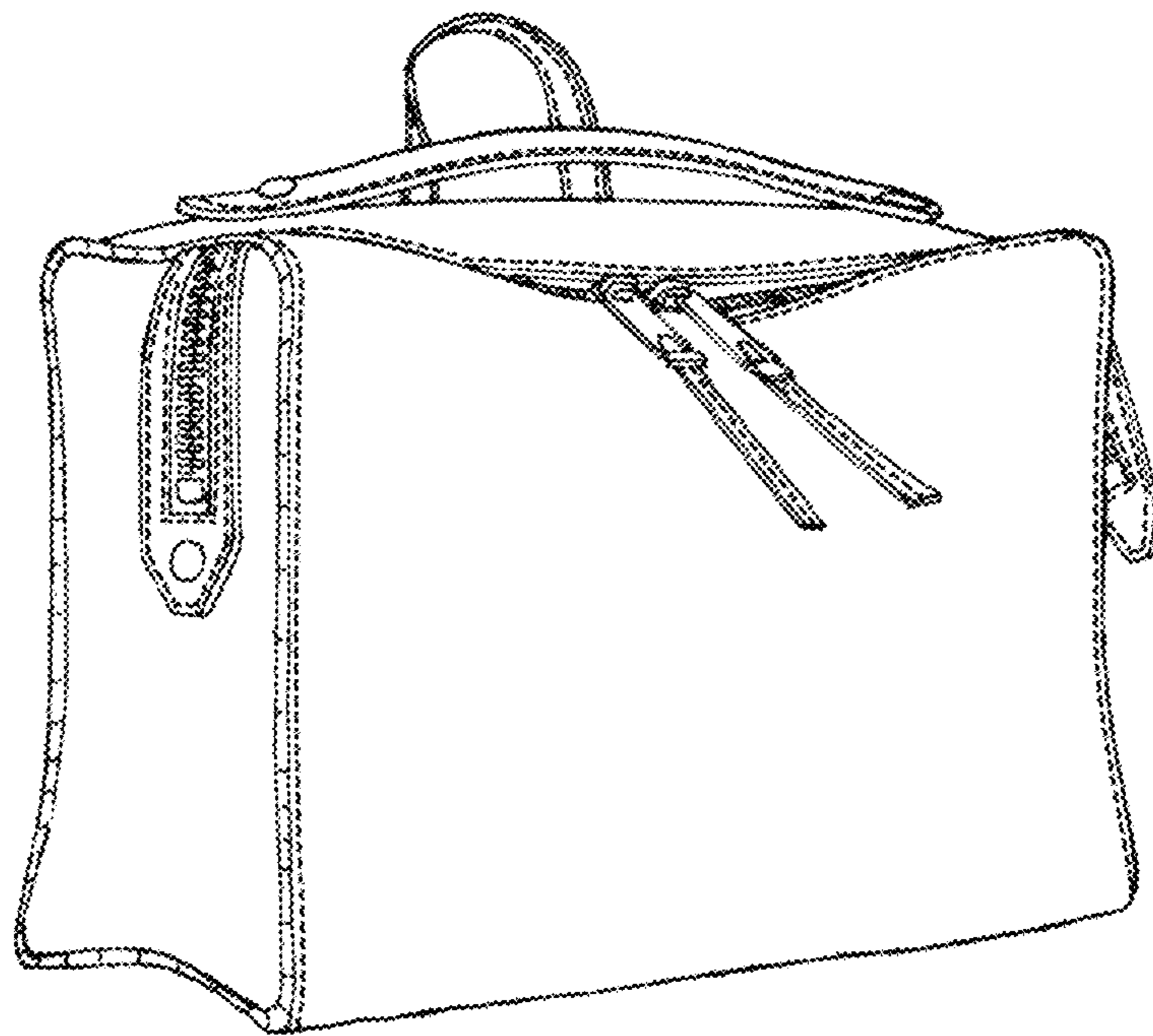

FIG.1

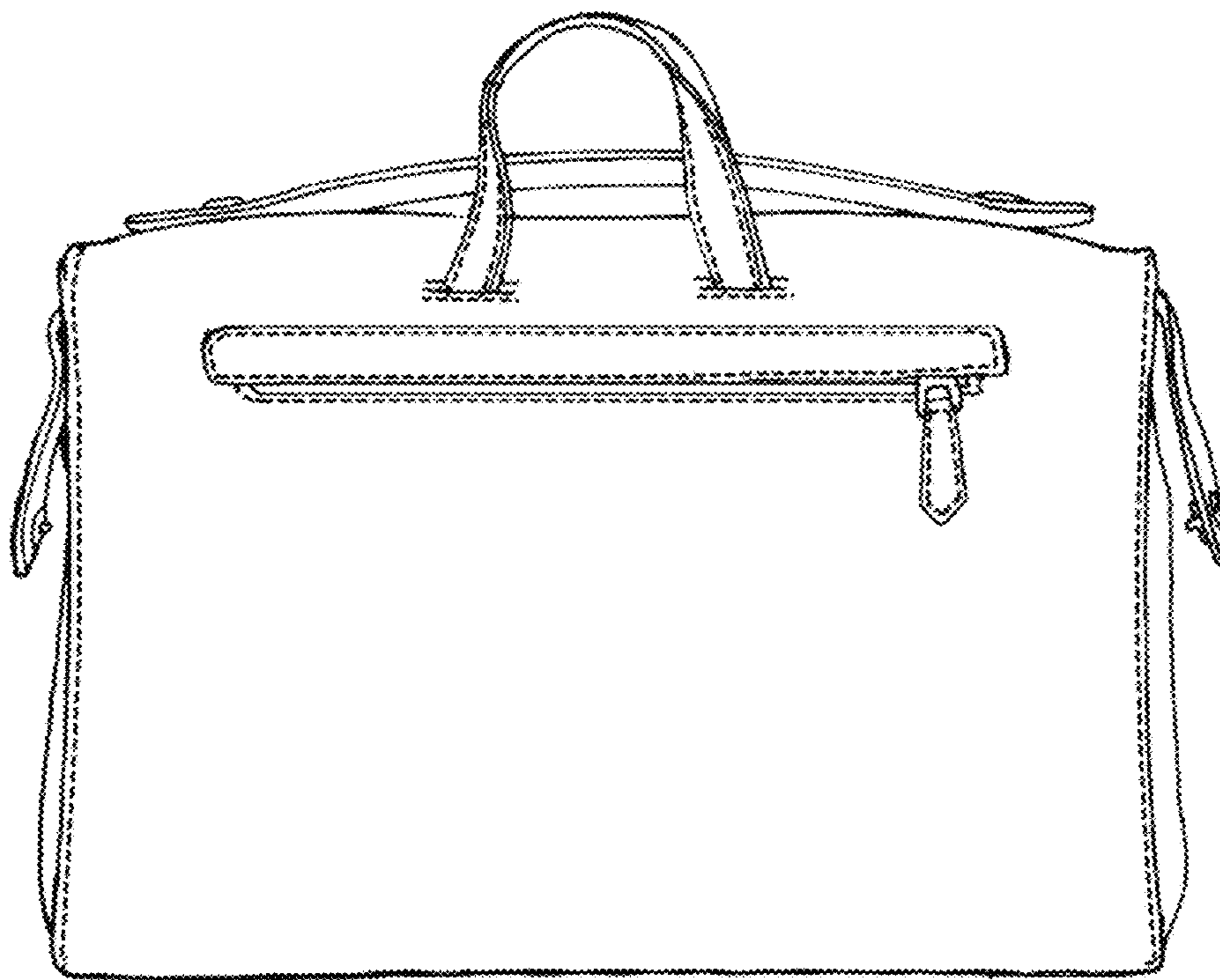

FIG. 2

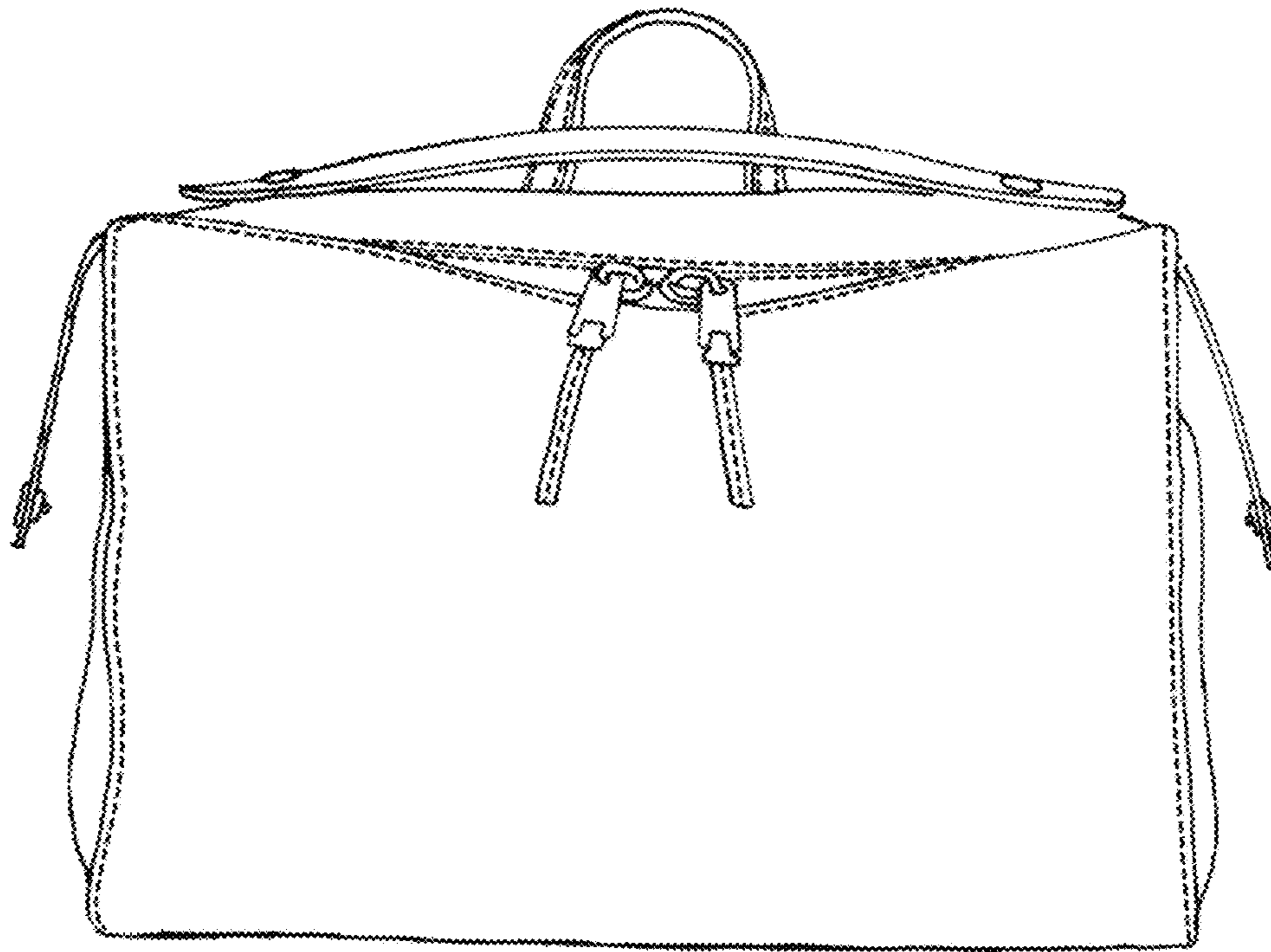

FIG. 3

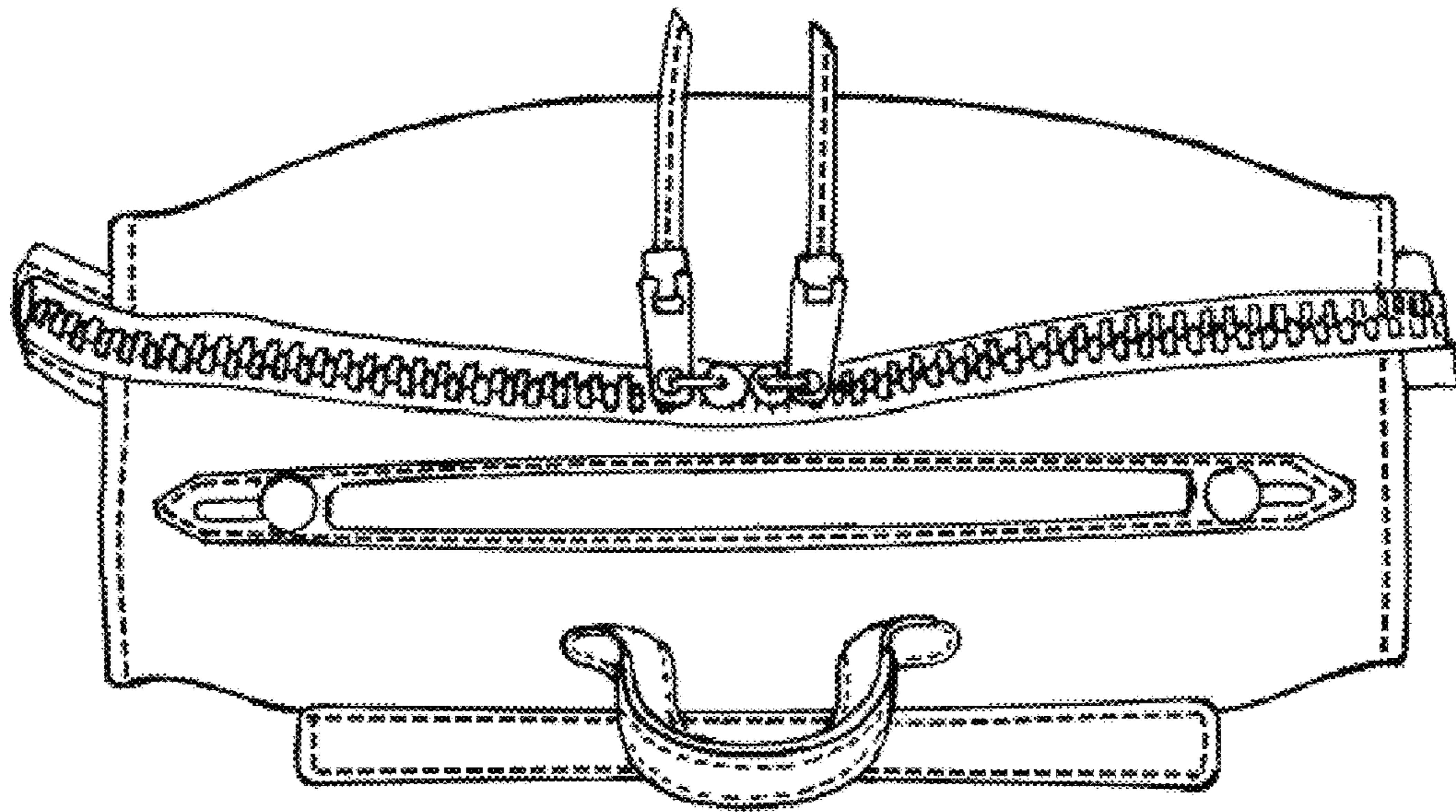

FIG. 4

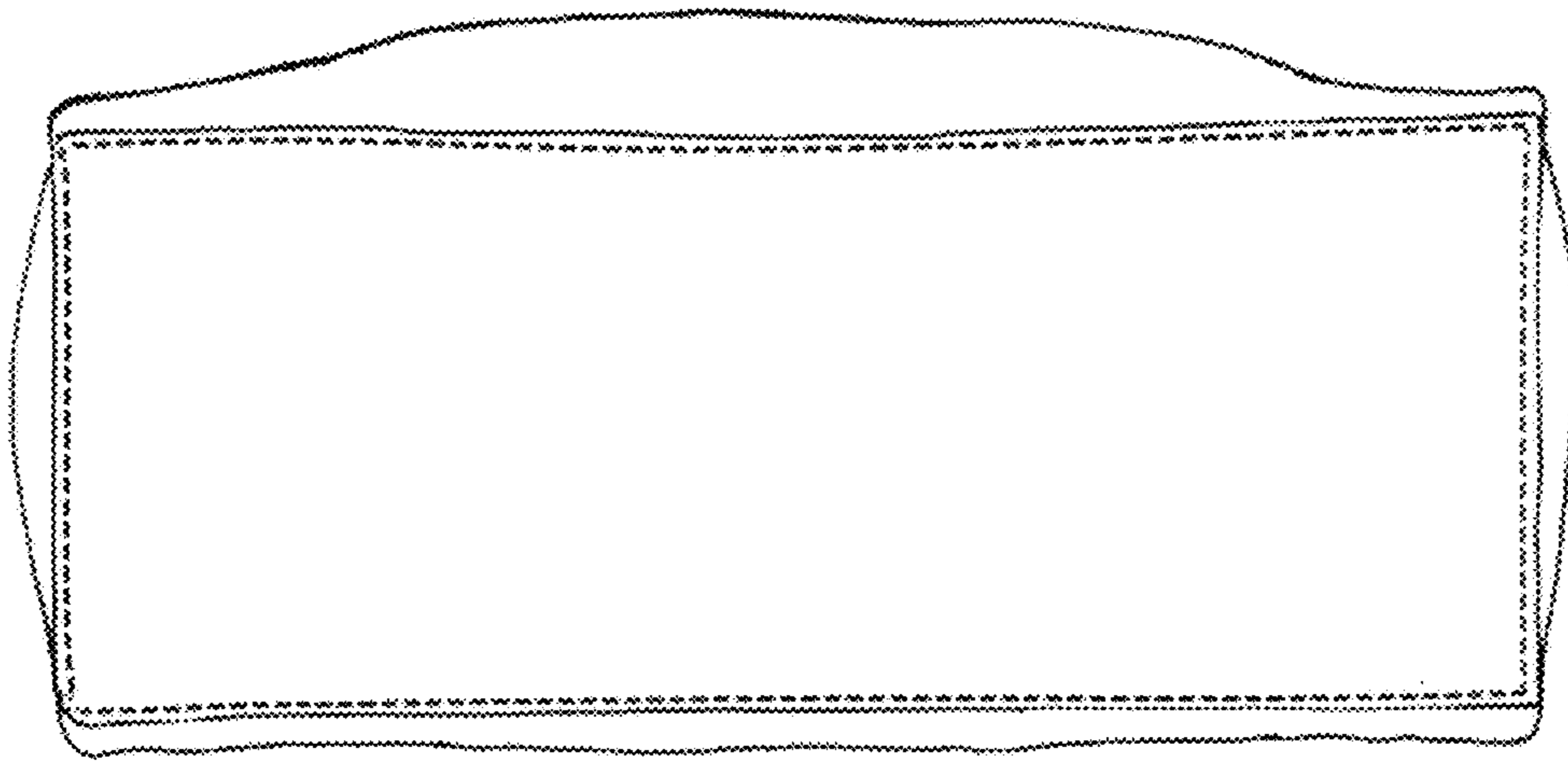

FIG. 5

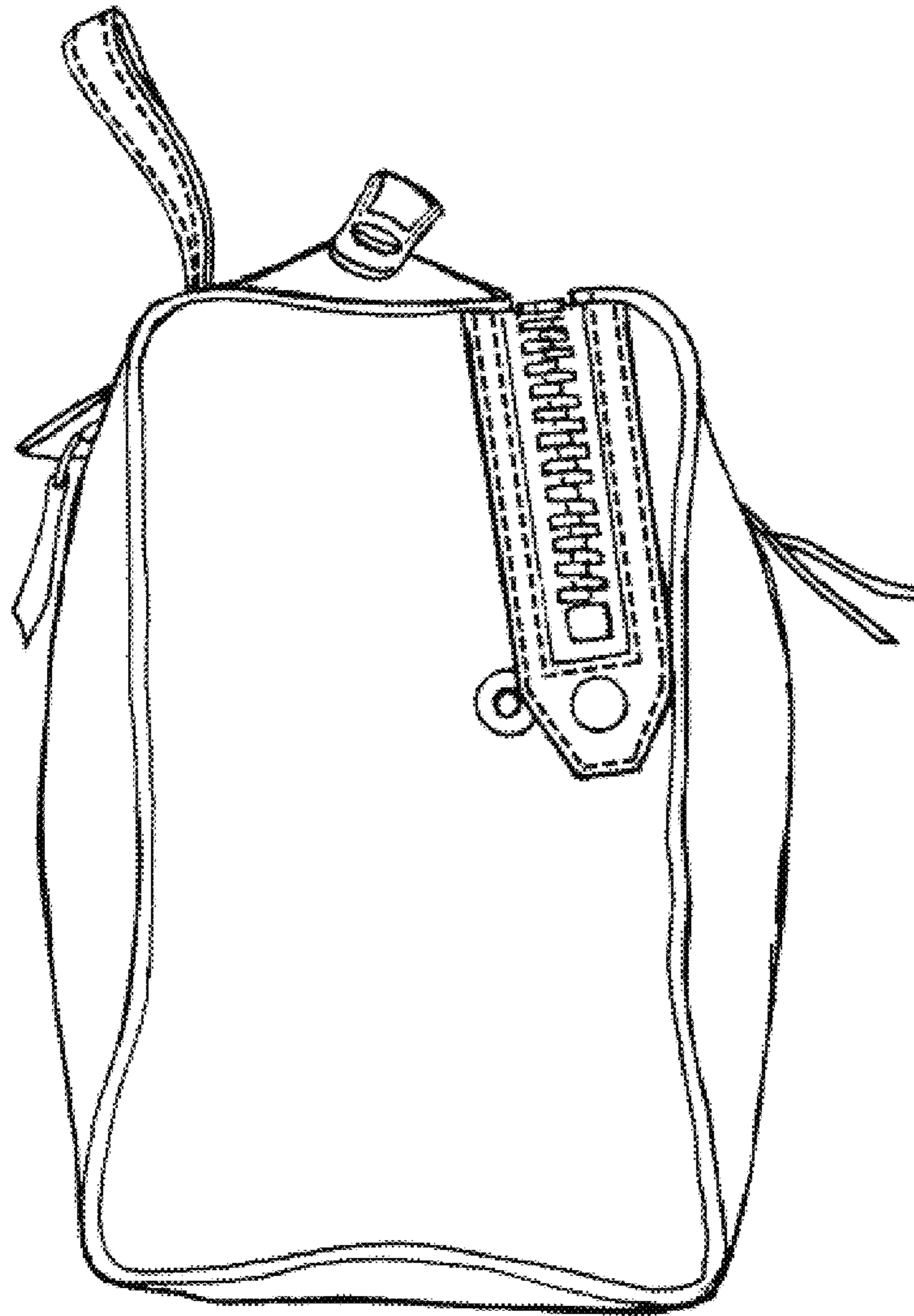

FIG. 6

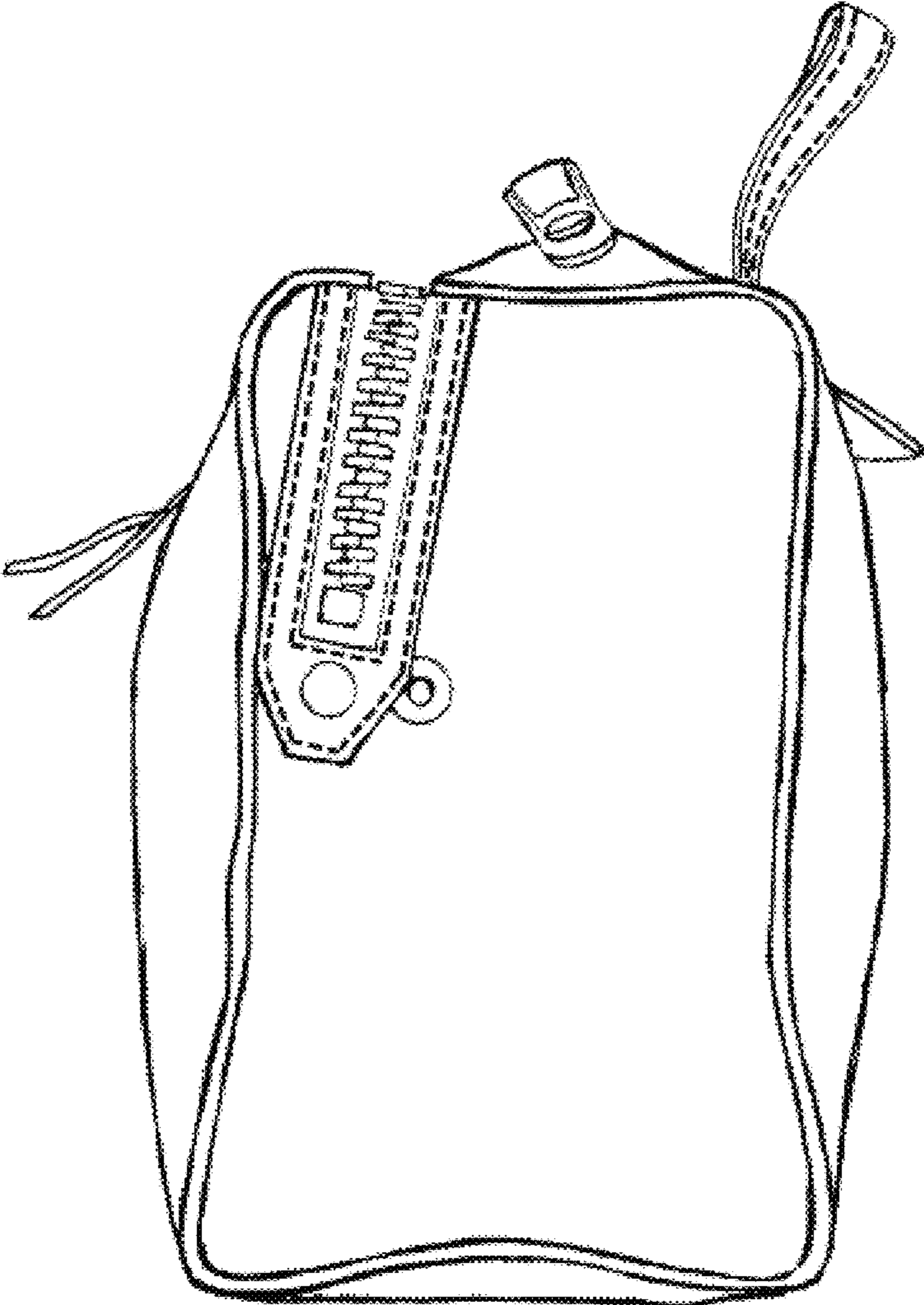

FIG. 7