



US00D794066S

(12) **United States Design Patent**
Hiramatsu et al.

(10) **Patent No.:** **US D794,066 S**
(45) **Date of Patent:** **** Aug. 8, 2017**

(54) **DISPLAY SCREEN WITH GRAPHICAL USER INTERFACE**

(71) Applicant: **Sony Interactive Entertainment Inc.**,
Tokyo (JP)

(72) Inventors: **Shuji Hiramatsu**, Tokyo (JP); **Taku Sugawara**, Tokyo (JP); **Ikuo Kobayashi**, Tokyo (JP)

(73) Assignee: **SONY INTERACTIVE ENTERTAINMENT INC.**, Tokyo (JP)

(**) Term: **15 Years**

(21) Appl. No.: **29/567,415**

(22) Filed: **Jun. 8, 2016**

Related U.S. Application Data

(62) Division of application No. 29/463,634, filed on Jan. 23, 2014.

(30) **Foreign Application Priority Data**

Nov. 1, 2013 (JP) D2013-025785
Nov. 1, 2013 (JP) D2013-025786
Nov. 1, 2013 (JP) D2013-025787

(51) **LOC (10) Cl.** **14-04**

(52) **U.S. Cl.**
USPC **D14/489**; D14/488

(58) **Field of Classification Search**
USPC D14/485-495
CPC G06F 3/0482; G06F 3/04842
See application file for complete search history.

(56) **References Cited**

U.S. PATENT DOCUMENTS

D321,903 S * 11/1991 Chepaitis D14/488
5,483,630 A * 1/1996 Unuma G06T 13/40
345/473
D396,457 S * 7/1998 Cappa D14/489
D434,778 S * 12/2000 Yee D14/489

(Continued)

OTHER PUBLICATIONS

FantasticalChris, PS4 How to use voice activation, Nov. 16, 2013, youtube.com [online], [site visited Sep. 13, 2016]. Available from Internet: <https://www.youtube.com/watch?v=e_sNpH1CvCI>.*

(Continued)

Primary Examiner — Karen Kearney

Assistant Examiner — Katherine Holbrow

(74) *Attorney, Agent, or Firm* — Michael Best and Friedrich LLP

(57) **CLAIM**

The ornamental design for a display screen with a graphical user interface, as shown and described.

DESCRIPTION

FIG. 1 is a first image for a display screen with a graphical user interface showing our new design;

FIG. 2 is a partial enlarged view of the first image thereof;

FIG. 3 is a partial enlarged view of a second image thereof;

FIG. 4 is a partial enlarged view of a third image thereof; and,

FIG. 5 is a partial enlarged view of a fourth image thereof.

The appearance of the image transitions between the images shown in FIGS. 2-5.

The process or period in which one image transitions to another forms no part of the claimed design.

The broken lines showing of the display screen and portions of the user interface form no part of the claimed design.

1 Claim, 5 Drawing Sheets

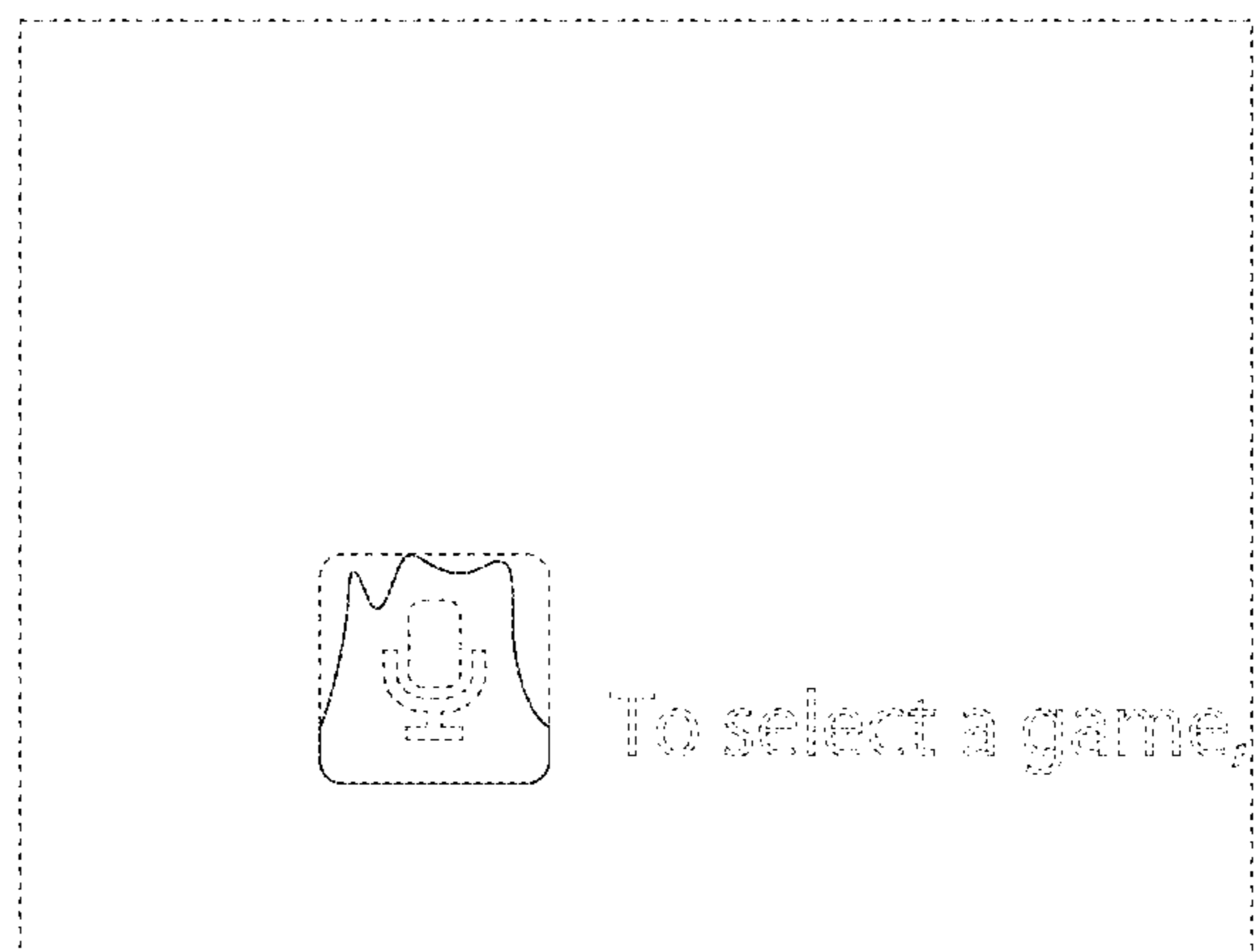
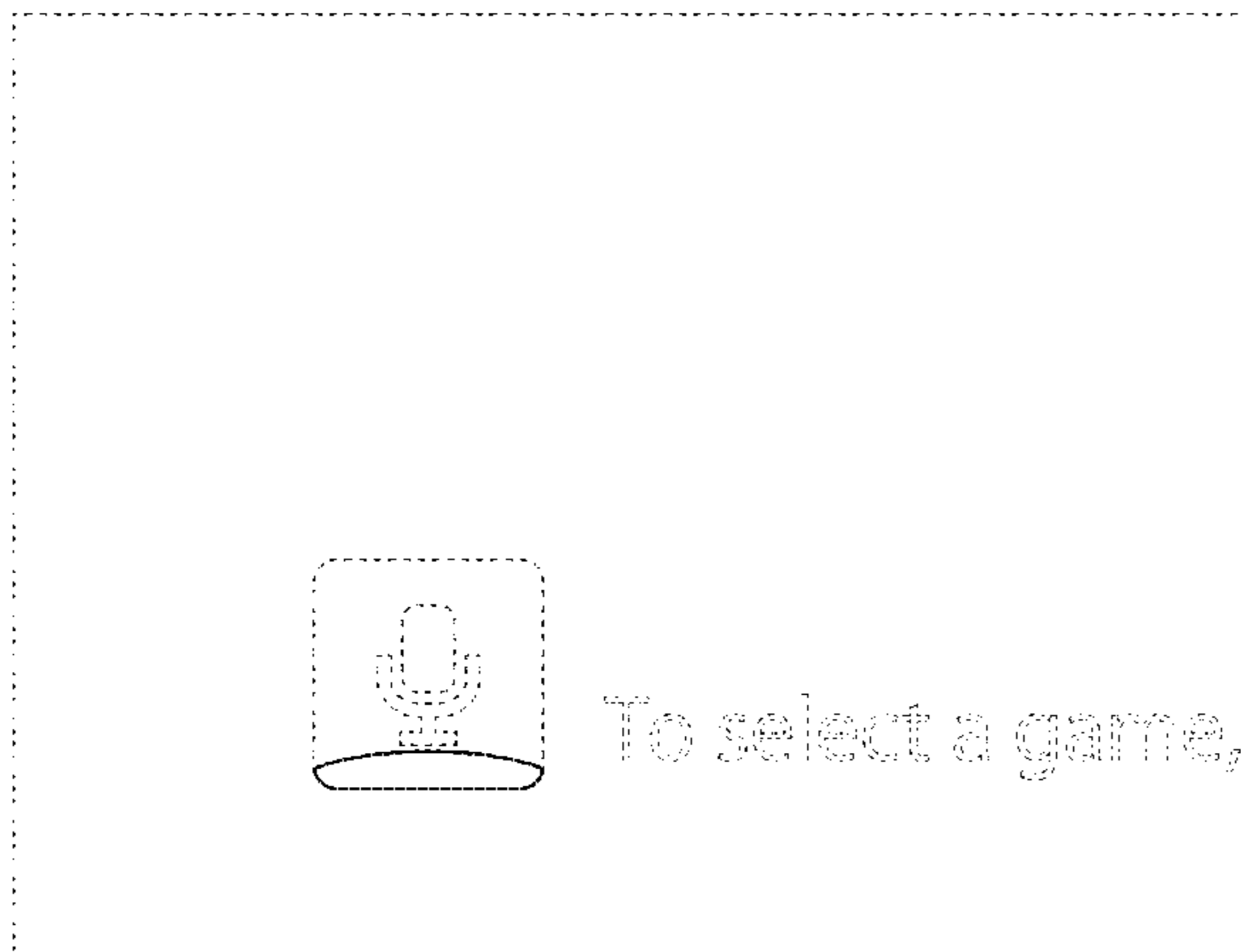

(56)

References Cited

U.S. PATENT DOCUMENTS

D472,902 S 4/2003 Nashida et al.
 6,571,185 B1* 5/2003 Gauland G01R 13/02
 345/440.1
 D523,442 S 6/2006 Hiramatsu
 D526,325 S* 8/2006 Fong D14/486
 D526,327 S* 8/2006 Braff D14/488
 D533,871 S* 12/2006 Stabb D14/485
 D547,323 S* 7/2007 Ivanov D14/489
 D597,101 S* 7/2009 Chaudhri D14/488
 D600,703 S* 9/2009 LaManna D14/492
 D626,141 S* 10/2010 Schilling D14/488
 D644,656 S* 9/2011 Maitlen D14/489
 D649,159 S* 11/2011 Viggers D14/492
 D652,047 S* 1/2012 Forsythe D14/485
 D652,428 S* 1/2012 Anzures D14/489
 D654,928 S* 2/2012 Morrow D14/492
 D654,929 S* 2/2012 Morrow D14/492
 D658,203 S* 4/2012 Hally D14/488
 D661,703 S 6/2012 Okumura et al.
 D682,881 S* 5/2013 Davydov D14/492
 8,465,397 B2* 6/2013 Saalasti A61B 5/024
 482/8
 D689,098 S* 9/2013 Jang D14/492
 D702,709 S* 4/2014 Dellinger D14/489
 D704,218 S* 5/2014 Ahn D14/492
 D704,219 S* 5/2014 Ahn D14/492
 D714,328 S* 9/2014 Wood D14/485
 D714,812 S* 10/2014 Kim D14/485
 D716,820 S* 11/2014 Wood D14/485
 D726,218 S* 4/2015 Marianek D14/489
 D736,792 S* 8/2015 Brinda D14/485

D738,910 S* 9/2015 Drozd D14/488
 D744,500 S* 12/2015 Lee D14/485
 D745,018 S* 12/2015 Balles D14/485
 D752,100 S* 3/2016 Anzures D14/492
 D759,679 S* 6/2016 Behar D14/485
 D759,680 S* 6/2016 Behar D14/485
 D760,759 S* 7/2016 Butcher D14/486
 D763,922 S* 8/2016 Huang D14/493
 D765,679 S* 9/2016 Balles D14/485
 D766,275 S* 9/2016 Balles D14/485
 D767,582 S* 9/2016 Kim D14/485
 D767,622 S* 9/2016 Lee D14/485
 D773,527 S* 12/2016 Butcher D14/486
 2003/0112262 A1* 6/2003 Adatia G06F 3/0481
 715/716
 2008/0235248 A1* 9/2008 Krantz G06F 3/033
 2010/0313125 A1* 12/2010 Fleizach G06F 3/04883
 715/702
 2011/0275418 A1* 11/2011 Forstall G06F 3/0488
 455/566

OTHER PUBLICATIONS

Marine Sargent, France TV Education Icons, Jan. 30, 2013, dribbble.com [online], [site visited Sep. 13, 2016]. Available from Internet: <<https://dribbble.com/shots/918972-FranceTV-Education-Icons>>.*
 Vova9, Microphone button animated, Sep. 14, 2012, dribbble.com [online], [site visited Sep. 13, 2016]. Available from Internet: <<https://dribbble.com/shots/730079-Microphone-button-animated>>.*

* cited by examiner

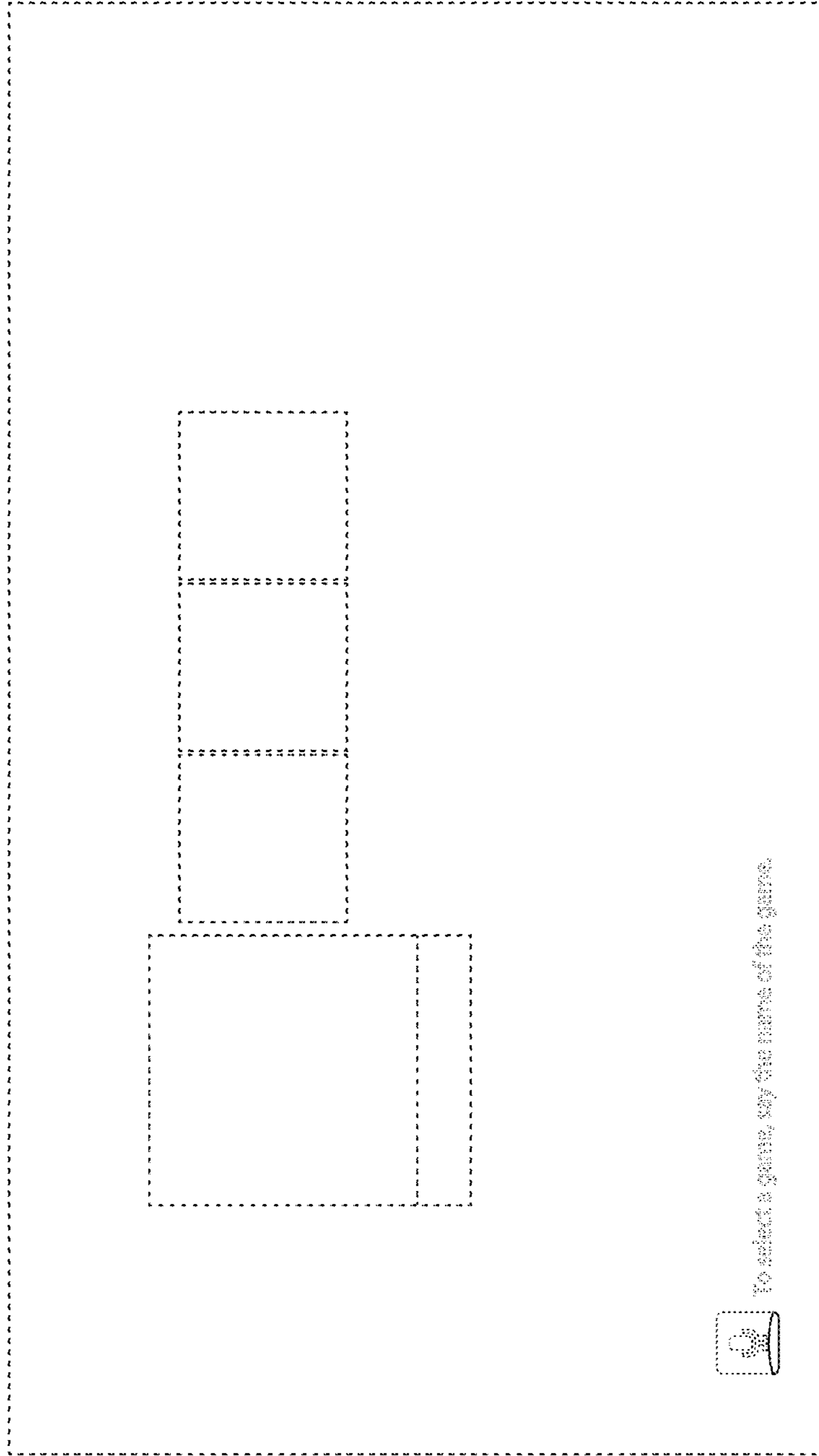

FIG. 1

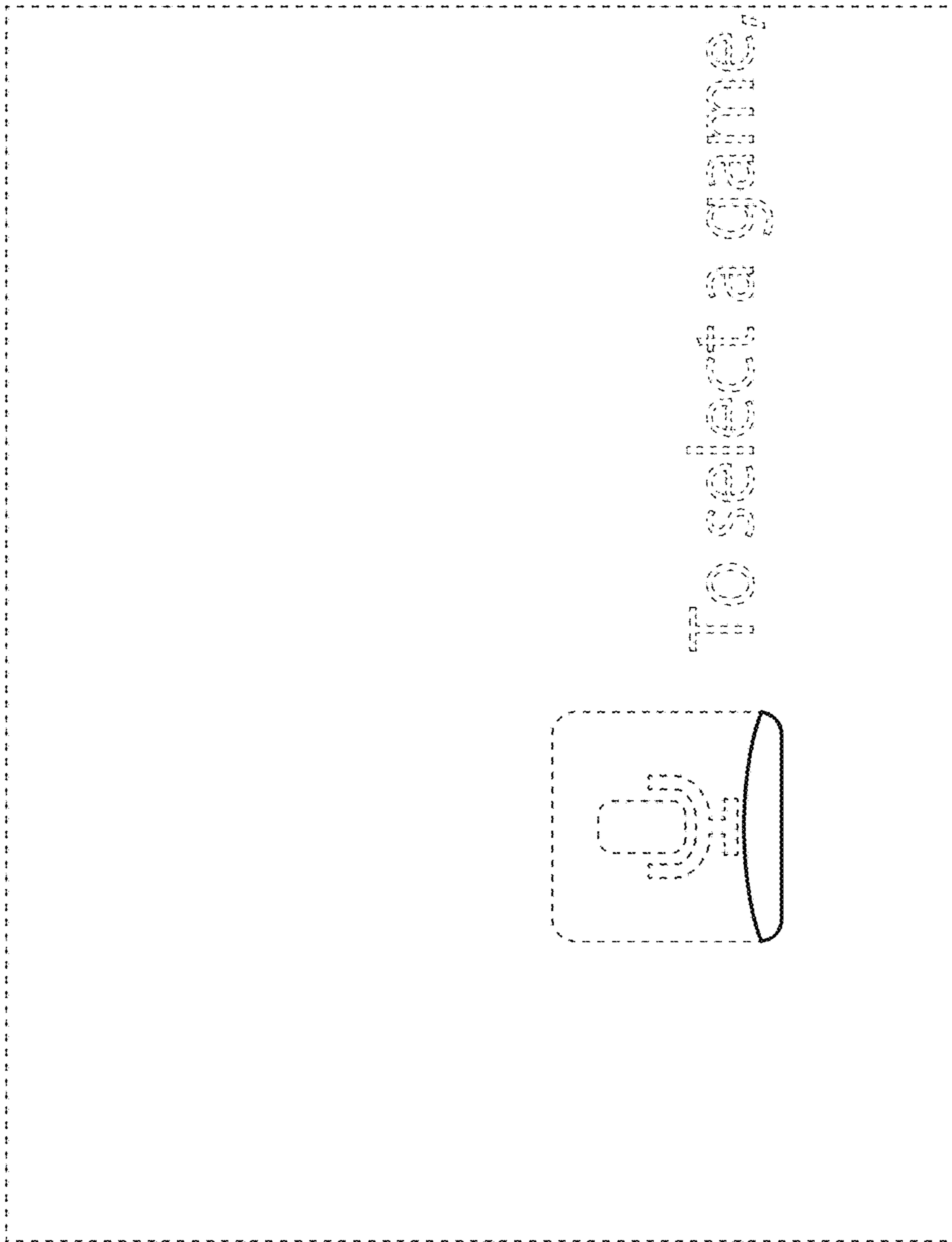

FIG. 2

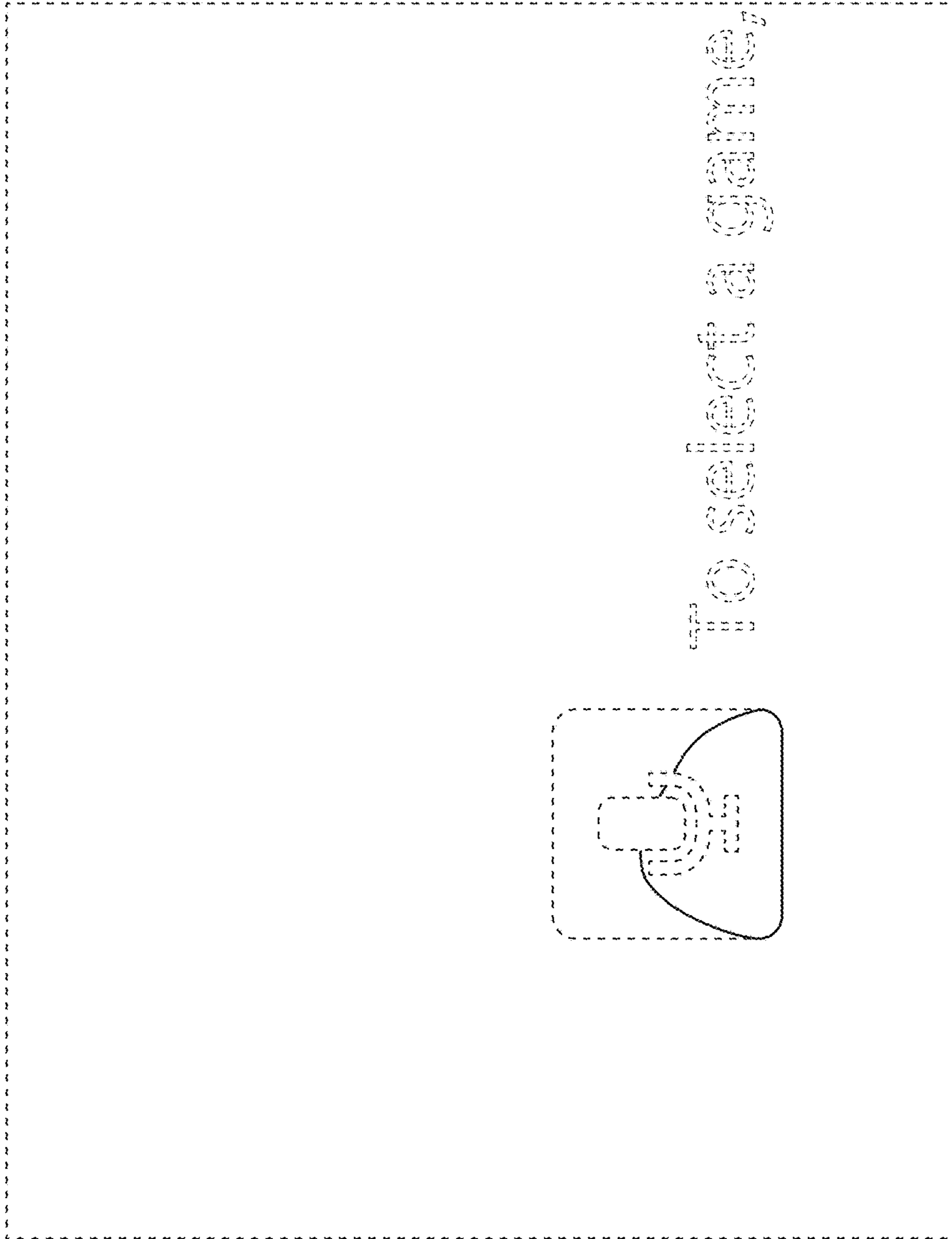

FIG. 3

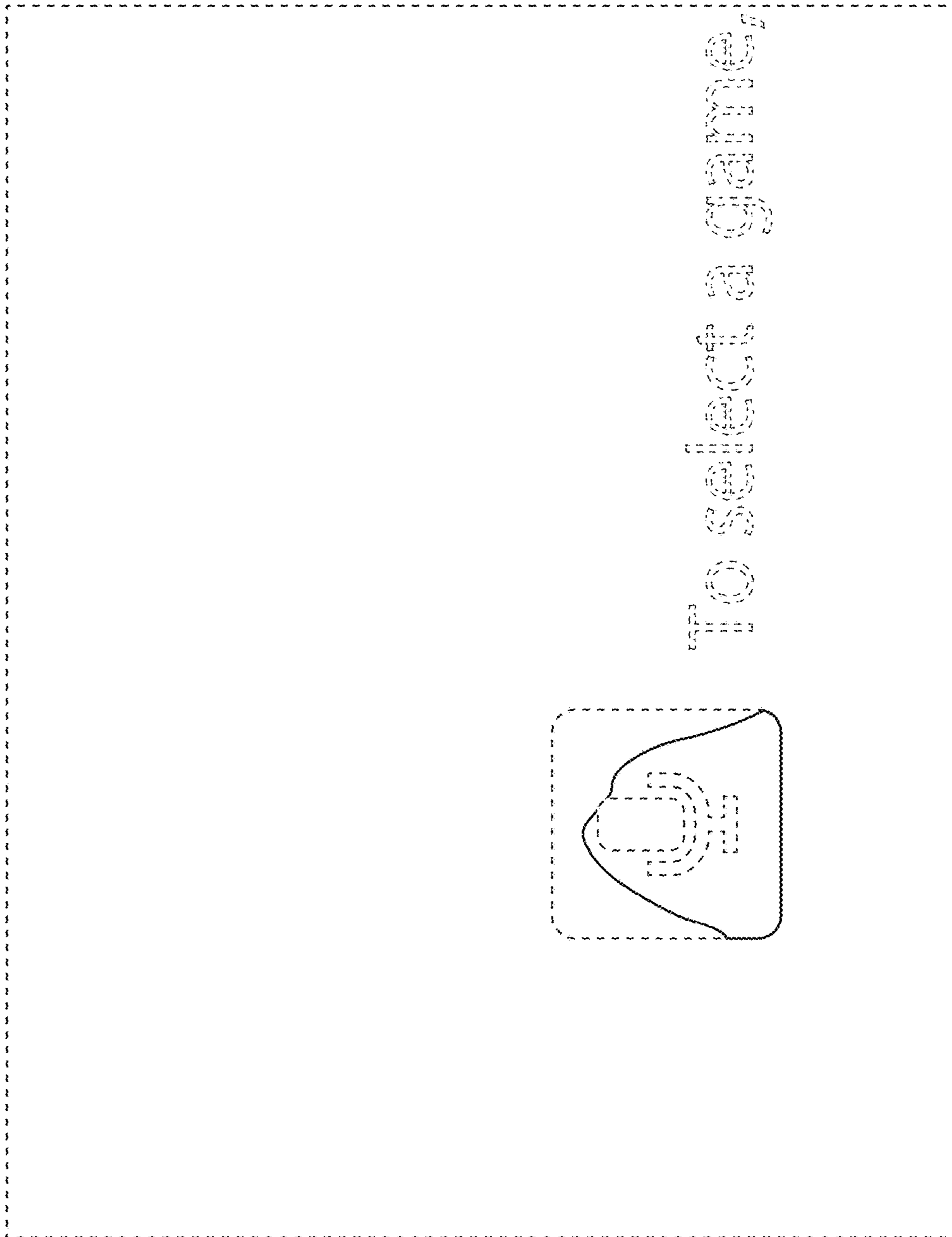

FIG. 4

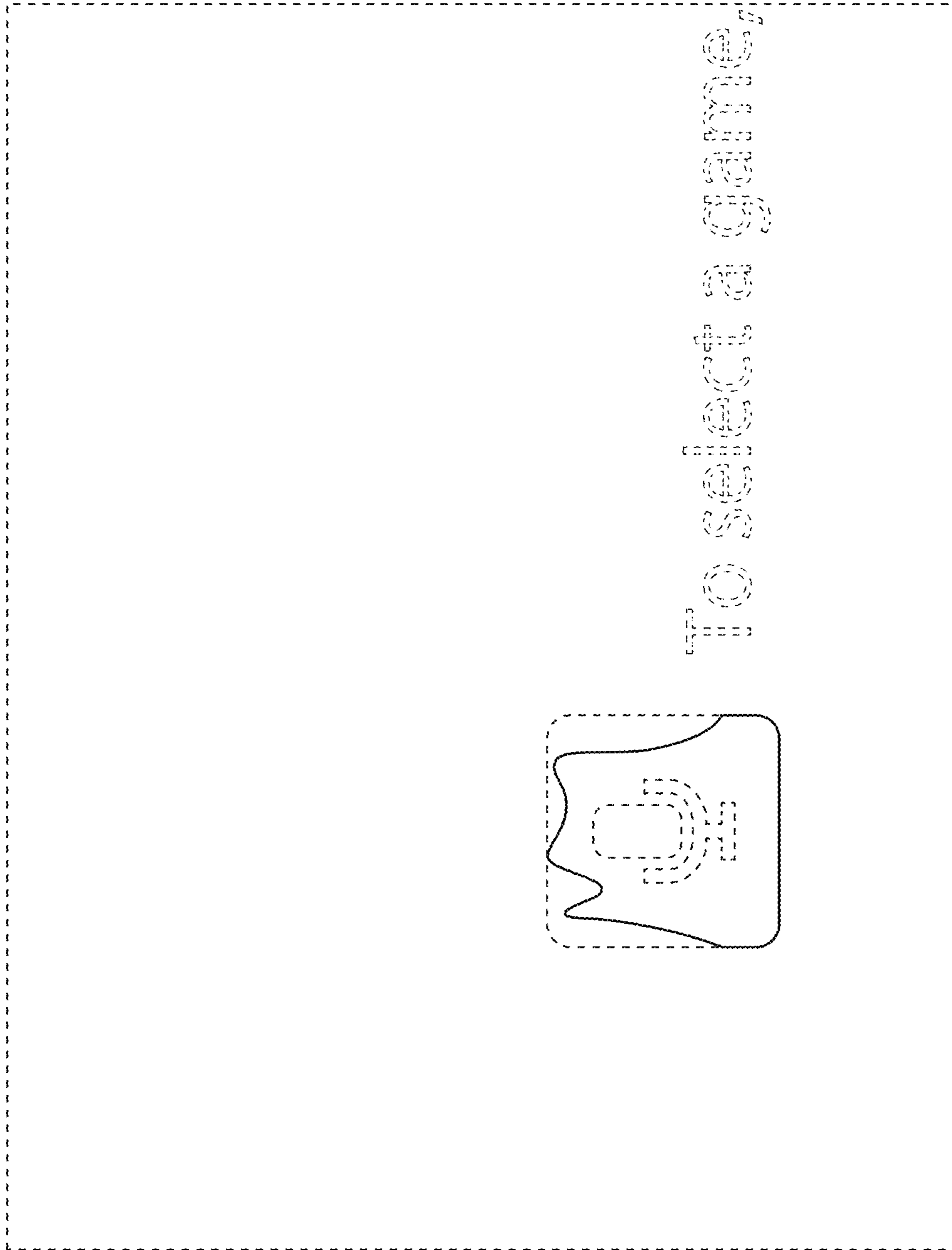

FIG. 5