



US00D793953S

(12) **United States Design Patent** (10) **Patent No.:** **US D793,953 S**
Ritterling et al. (45) **Date of Patent:** **** Aug. 8, 2017**

(54) **BATTERY**

(71) Applicant: **Techtronic Industries Co. Ltd.**, Tsuen Wan, New Territories (HK)

(72) Inventors: **Douglas Ritterling**, Chagrin Falls, OH (US); **Shane Glasgow**, Reminderville, OH (US)

(73) Assignee: **Techtronic Industries Co. Ltd.**, Tsuen Wan, New Territories (HK)

(**) Term: **15 Years**

(21) Appl. No.: **29/581,581**

(22) Filed: **Oct. 20, 2016**

Related U.S. Application Data

(63) Continuation of application No. 29/528,139, filed on May 26, 2015, now Pat. No. Des. 772,806.

Foreign Application Priority Data

Nov. 26, 2014 (CN) 2014 3 0476283

(51) **LOC (10) Cl.** **13-02**

(52) **U.S. Cl.**
USPC **D13/103**

(58) **Field of Classification Search**
USPC D13/102-110, 118-119, 184, 199;
D14/356, 432, 251, 253, 434,
D14/203.3-203.8, 217, 248, 250, 252,
D14/440, 450, 496; D3/201, 218, 269,
D3/301, 273, 303
CPC Y02E 60/12; Y02E 60/122; Y02E 60/124;
Y02E 60/50; Y02E 60/10; H01M 2/02;
H01M 2/022; H01M 2/0202; H01M
2/0207; H01M 2/0212; H01M 2/1061;
H01M 2/1022; H01M 2/1055; H01M
2/1066; H01M 2/105; H01M 2/204;
H01M 2/20; H01M 2/202; H01M 2/206;

H01M 10/44; H01M 10/46; H01M
10/465; H01M 10/482; H01M 10/4257;
H01M 10/0436; H01M 10/48; H01M
10/425; H01M 2200/30; H01M 2250/30;
H01M 2250/40; H02J 7/00; H02J 7/0003;
H02J 7/0011; H02J 7/0013; H02J 7/0054;
H02J 7/0055; H02J 7/0057; H02J 7/025;
H02J 7/0042; H02J 7/0044;

(Continued)

(56) **References Cited**

U.S. PATENT DOCUMENTS

5,553,675 A 9/1996 Pitzen et al.
5,589,288 A 12/1996 Coulson et al.
5,607,792 A 3/1997 Garcia et al.

(Continued)

Primary Examiner — Rosemary K Tarcza

Assistant Examiner — Christy Nemeth

(74) *Attorney, Agent, or Firm* — Michael Best & Friedrich LLP

(57) **CLAIM**

We claim the ornamental design for a battery, as shown and described.

DESCRIPTION

FIG. 1 is a perspective view of a battery;
FIG. 2 is a back side view of the battery shown in FIG. 1.
FIG. 3 is a front side view of the battery shown in FIG. 1.
FIG. 4 is a right side view of the battery shown in FIG. 1.
FIG. 5 is a left side view of the battery shown in FIG. 1.
FIG. 6 is a bottom side view of the battery shown in FIG. 1;
and,
FIG. 7 is a top side view of the battery shown in FIG. 1.
The elements shown in dashed lines are included for the purpose of illustrating environment and form no part of the claimed design.

1 Claim, 4 Drawing Sheets

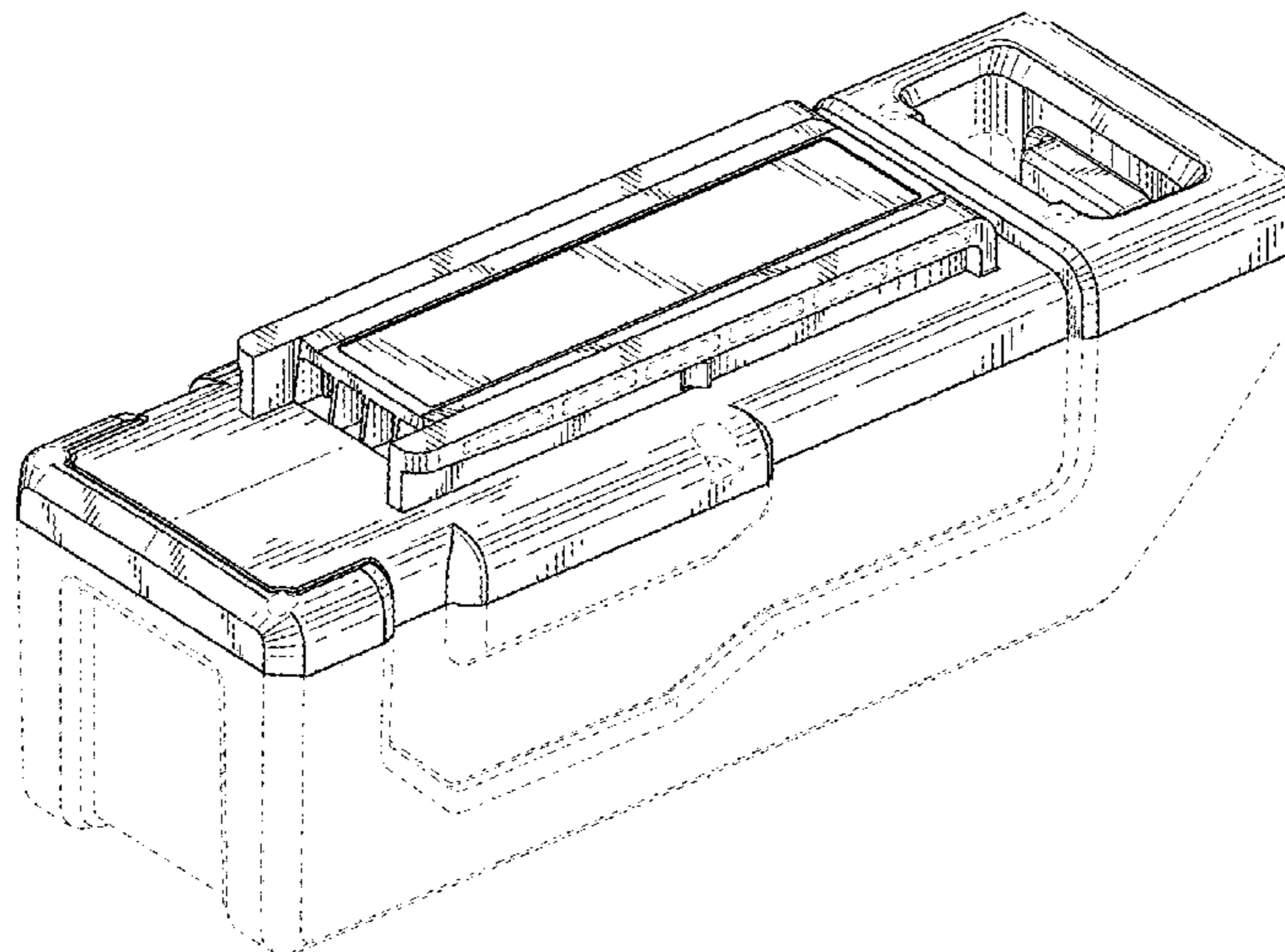

(58) **Field of Classification Search**
 CPC . H02J 7/0045; H02J 2007/0062; H01F 38/14;
 H01R 13/6675
 See application file for complete search history.

(56) **References Cited**

U.S. PATENT DOCUMENTS

5,663,011 A	9/1997	Bunyea et al.	RE40,681 E	3/2009	Pitzen et al.
5,681,667 A	10/1997	Bunyea et al.	7,507,041 B2	3/2009	Ueda et al.
5,718,985 A	2/1998	Bunyea et al.	7,534,065 B2	5/2009	Rejman et al.
5,792,573 A	8/1998	Pitzen et al.	7,554,287 B2	6/2009	Duesselberg
5,800,940 A	9/1998	Bunyea et al.	RE40,848 E	7/2009	Pitzen et al.
5,851,692 A	12/1998	Potts	7,557,534 B2	7/2009	Uehlein-Proctor et al.
5,856,038 A	1/1999	Mason	7,567,058 B2	7/2009	Shimizu et al.
5,869,204 A	2/1999	Kottke et al.	7,572,547 B2	8/2009	Sakakibara
5,986,865 A	11/1999	Umeki et al.	7,597,993 B2	10/2009	Glauning et al.
6,057,608 A	5/2000	Bailey, Jr. et al.	7,598,705 B2	10/2009	Watson et al.
6,132,900 A	10/2000	Yoshizawa et al.	7,602,144 B2	10/2009	Seo
6,168,881 B1	1/2001	Fischer et al.	7,638,236 B2	12/2009	Ugaji et al.
6,181,032 B1	1/2001	Marshall et al.	7,648,383 B2	1/2010	Matthias et al.
6,223,835 B1	5/2001	Habedank et al.	7,655,350 B2	2/2010	White et al.
6,304,058 B2	10/2001	Watson et al.	7,661,486 B2	2/2010	Turner et al.
6,326,101 B1	12/2001	White et al.	7,670,171 B2	3/2010	Hirt
6,329,788 B1	12/2001	Bailey, Jr. et al.	7,670,714 B2	3/2010	Matthias
6,357,533 B1	3/2002	Buchholz et al.	7,679,323 B2	3/2010	Roehm et al.
6,357,534 B1	3/2002	Buetow et al.	7,682,726 B2	3/2010	Rejman et al.
6,412,572 B2	7/2002	Habedank et al.	D614,178 S	4/2010	Nuovo et al.
6,500,581 B2	12/2002	White et al.	7,718,306 B2	5/2010	Cheon et al.
6,515,451 B2	2/2003	Watson et al.	7,723,960 B2	5/2010	Funabashi et al.
6,590,396 B1	7/2003	Zur et al.	7,746,030 B2	6/2010	Ziegler et al.
6,623,049 B2	9/2003	Shreeve et al.	7,758,996 B2	7/2010	Mackle et al.
6,641,950 B2	11/2003	White et al.	7,759,898 B2	7/2010	Brotto
6,653,815 B2	11/2003	Watson et al.	7,765,641 B2	8/2010	Cunningham
6,656,626 B1	12/2003	Mooty et al.	7,782,626 B2	8/2010	Buck et al.
D487,426 S	3/2004	Johnson	7,816,888 B2	10/2010	Rejman et al.
6,729,413 B2	5/2004	Turner et al.	7,828,185 B2	11/2010	Hofmann et al.
6,730,432 B1	5/2004	Grosfeld et al.	7,838,151 B2	11/2010	Koga et al.
6,742,601 B2	6/2004	Numata	7,858,224 B2	12/2010	Kim et al.
6,840,335 B1	1/2005	Wu	7,879,479 B2	2/2011	Roehm et al.
6,876,173 B2	4/2005	Mastaler et al.	7,879,482 B2	2/2011	Matthias
6,921,285 B2	7/2005	Glauning	7,879,483 B2	2/2011	Sakakibara
6,933,689 B2	8/2005	Yamamoto	7,883,360 B2	2/2011	Hirt
6,940,033 B1	9/2005	Jones, Jr. et al.	7,887,942 B2	2/2011	Rejman et al.
6,955,549 B2	10/2005	Brazell et al.	7,932,694 B2	4/2011	Watanabe et al.
6,965,213 B2	11/2005	Schadoffsky et al.	7,935,436 B2	5/2011	Cheon et al.
6,965,214 B2	11/2005	Kubale et al.	7,937,792 B2	5/2011	Munn et al.
6,996,909 B1	2/2006	Buck et al.	7,940,025 B2	5/2011	Duesselberg
7,005,831 B2	2/2006	Watson et al.	D640,197 S *	6/2011	Park D13/103
7,022,878 B2	4/2006	Arai et al.	7,963,150 B2	6/2011	Haag
7,052,799 B2	5/2006	Zatezalo et al.	7,989,969 B2	8/2011	Grant et al.
7,087,137 B2	8/2006	Motoda	7,993,772 B2	8/2011	Sakakibara
7,091,625 B2	8/2006	Okusawa et al.	7,997,352 B2	8/2011	Hashimoto et al.
7,121,854 B2	10/2006	Buck et al.	7,999,507 B2	8/2011	Heinzen
7,125,268 B1	10/2006	Marukawa et al.	8,006,958 B2	8/2011	Starks et al.
7,125,270 B2	10/2006	Buck et al.	8,027,166 B2	9/2011	Lin
7,160,644 B2	1/2007	White et al.	8,054,041 B2	11/2011	Kim et al.
7,182,150 B2	2/2007	Grossman	8,062,782 B2	11/2011	Wang et al.
7,195,842 B1	3/2007	Fujimoto et al.	8,091,650 B2	1/2012	Van der Linde et al.
7,210,185 B2	5/2007	Paas	8,092,932 B2 *	1/2012	Phillips B25F 5/02 429/100
7,238,443 B2	7/2007	Sakakibara	8,097,354 B2	1/2012	Sakakibara
7,243,734 B2	7/2007	Wu	8,098,036 B2	1/2012	Matsunaga et al.
7,248,021 B2	7/2007	Kozu et al.	8,128,250 B2	3/2012	Parrinello
7,306,052 B2	12/2007	Vahabi-Nejad et al.	8,153,292 B2	4/2012	Takezawa
D559,175 S *	1/2008	Houghton D13/103	8,158,284 B2	4/2012	Kimura
7,318,731 B2	1/2008	Lin et al.	8,163,414 B2	4/2012	Wan et al.
7,319,305 B2	1/2008	Kimoto et al.	D659,088 S *	5/2012	Steinberg D13/106
7,322,835 B2	1/2008	Lin et al.	8,181,717 B2	5/2012	Turner et al.
7,351,077 B2	4/2008	Shimizu et al.	8,182,934 B2	5/2012	Asahina et al.
7,351,493 B2	4/2008	Uemoto et al.	8,183,836 B2	5/2012	Funabashi et al.
7,397,218 B2	7/2008	Rejman	8,228,029 B2	7/2012	Meyer et al.
7,400,106 B2	7/2008	DeCircco et al.	8,302,833 B2	11/2012	Gross et al.
7,407,727 B2	8/2008	Sugiyama et al.	8,305,042 B2	11/2012	Wirmitzer et al.
7,423,407 B2	9/2008	Watson et al.	8,312,937 B2	11/2012	Turner et al.
7,429,430 B2	9/2008	Mooty et al.	8,318,347 B2	11/2012	Yokoyama et al.
7,445,139 B2	11/2008	Okouchi	8,323,839 B2	12/2012	Tamura et al.
7,455,544 B2	11/2008	Glauning et al.	8,350,512 B2	1/2013	Matsunaga et al.
			8,354,183 B2	1/2013	Konuma et al.
			8,355,760 B2	1/2013	Kim
			8,365,350 B2	2/2013	Cochran et al.
			8,389,143 B2	3/2013	Roßkamp et al.
			8,395,340 B2	3/2013	Marvelly
			8,409,739 B2	4/2013	Ouyang
			8,426,051 B2	4/2013	Sakakibara
			8,440,340 B2	5/2013	Zhang
			8,450,003 B2	5/2013	Ouyang

(56)

References Cited

U.S. PATENT DOCUMENTS

8,508,189 B2	8/2013	Osswald et al.		2010/0209754 A1	8/2010	Zuo	
8,557,427 B2	10/2013	Matsumoto		2010/0221591 A1	9/2010	Roßkamp et al.	
8,563,163 B2	10/2013	Hayashi et al.		2011/0011443 A1	1/2011	Yata et al.	
8,573,324 B2	11/2013	Turner et al.		2011/0027662 A1	2/2011	Nishimura et al.	
8,580,416 B2	11/2013	Cao		2011/0116861 A1	5/2011	Zhang et al.	
D694,709 S *	12/2013	Scharf	D13/110	2011/0133496 A1	6/2011	Cooper	
8,643,339 B2	2/2014	Iwamura et al.		2011/0147027 A1	6/2011	Blum et al.	
8,658,302 B2	2/2014	Gong		2011/0214891 A1	9/2011	Roehm	
8,664,914 B2	3/2014	Toya et al.		2011/0250483 A1	10/2011	Liu	
8,679,665 B2	3/2014	Heinzen et al.		2011/0279133 A1	11/2011	Harper et al.	
8,701,793 B2	4/2014	Van der Linde et al.		2012/0052356 A1	3/2012	Sugiura et al.	
8,730,053 B2	5/2014	Dycus		2012/0055687 A1	3/2012	Martinsson	
D706,712 S *	6/2014	Lampe	D13/110	2012/0058384 A1	3/2012	Ogura	
8,741,461 B2	6/2014	Yoneda et al.		2012/0164523 A1	6/2012	Yoshikawa et al.	
8,741,467 B2	6/2014	Sakakibara		2012/0171539 A1	7/2012	Rejman et al.	
8,742,349 B2	6/2014	Urbon et al.		2012/0176097 A1	7/2012	Takezawa et al.	
D722,022 S *	2/2015	Dasbach	D13/110	2012/0196169 A1	8/2012	Jeong et al.	
D772,806 S *	11/2016	Ritterling	B25F 5/02 D13/103	2012/0247796 A1	10/2012	Mueller et al.	
2002/0125857 A1	9/2002	Mastaler et al.		2012/0282503 A1	11/2012	Fujikawa et al.	
2002/0160255 A1	10/2002	Babcock et al.		2012/0302101 A1	11/2012	Brotto et al.	
2002/0160273 A1	10/2002	Arai et al.		2012/0317948 A1	12/2012	Abe et al.	
2004/0081882 A1	4/2004	Ontl		2012/0317950 A1	12/2012	Abe et al.	
2004/0106036 A1	6/2004	Geis et al.		2012/0322321 A1	12/2012	Kwag et al.	
2005/0008938 A1	1/2005	Cho et al.		2013/0031762 A1	2/2013	Chellew et al.	
2005/0073283 A1	4/2005	Friedli et al.		2013/0048929 A1	2/2013	Starks et al.	
2005/0142447 A1	6/2005	Nakai et al.		2013/0093142 A1	4/2013	Saur et al.	
2005/0156566 A1	7/2005	Thorsoe et al.		2013/0106343 A1	5/2013	Cruise et al.	
2005/0234594 A1	10/2005	Uehigashi		2013/0136956 A1*	5/2013	Nakano	H01M 2/105 429/7
2005/0247613 A1	11/2005	Bishop et al.		2013/0164589 A1	6/2013	Ota et al.	
2006/0121342 A1	6/2006	Sano et al.		2013/0187461 A1	7/2013	Goto et al.	
2006/0199072 A1	9/2006	Lui et al.		2013/0234655 A1	9/2013	Miwa et al.	
2007/0139847 A1	6/2007	Liu		2013/0255980 A1	10/2013	Linehan et al.	
2007/0209119 A1	9/2007	Chun-Chu		2013/0277081 A1	10/2013	Hayashi et al.	
2007/0243424 A1	10/2007	Lin et al.		2013/0316207 A1	11/2013	Suwa	
2008/0041874 A1	2/2008	Attaway		2013/0323549 A1	12/2013	Choi et al.	
2008/0050655 A1	2/2008	Chu et al.		2013/0330576 A1*	12/2013	Kolden	H01M 10/425 429/7
2008/0113262 A1*	5/2008	Phillips	H01M 2/105 429/149	2014/0004397 A1	1/2014	Lee et al.	
2008/0187835 A1	8/2008	Takezawa et al.		2014/0011060 A1	1/2014	Yang et al.	
2008/0211327 A1	9/2008	Schlegel et al.		2014/0014386 A1	1/2014	Turner et al.	
2008/0220324 A1*	9/2008	Phillips	B25F 5/02 429/120	2014/0017528 A1	1/2014	Uehara et al.	
2008/0241666 A1	10/2008	Baba et al.		2014/0028223 A1	1/2014	Yoshida et al.	
2008/0311795 A1	12/2008	Brotto et al.		2014/0045049 A1	2/2014	Iyori et al.	
2008/0314792 A1	12/2008	Daeschler et al.		2014/0053688 A1	2/2014	Yaschur et al.	
2009/0255084 A1	10/2009	Gee, II et al.		2014/0088753 A1	3/2014	Lim et al.	
2009/0276974 A1	11/2009	Khalil et al.		2014/0091644 A1	4/2014	Wirmitzer et al.	
2009/0289805 A1	11/2009	Patrick et al.		2014/0103840 A1	4/2014	Lim	
2010/0086840 A1	4/2010	Shao		2014/0131959 A1	5/2014	Tussing	
2010/0112437 A1	5/2010	Yoshikawa et al.		2014/0147718 A1	5/2014	Furui et al.	
2010/0192314 A1	8/2010	Otsuka et al.		2014/0158389 A1	6/2014	Ito et al.	
				2014/0161513 A1	6/2014	Chellew et al.	
				2014/0167676 A1	6/2014	Mack	
				2014/0174775 A1	6/2014	Parks	

* cited by examiner

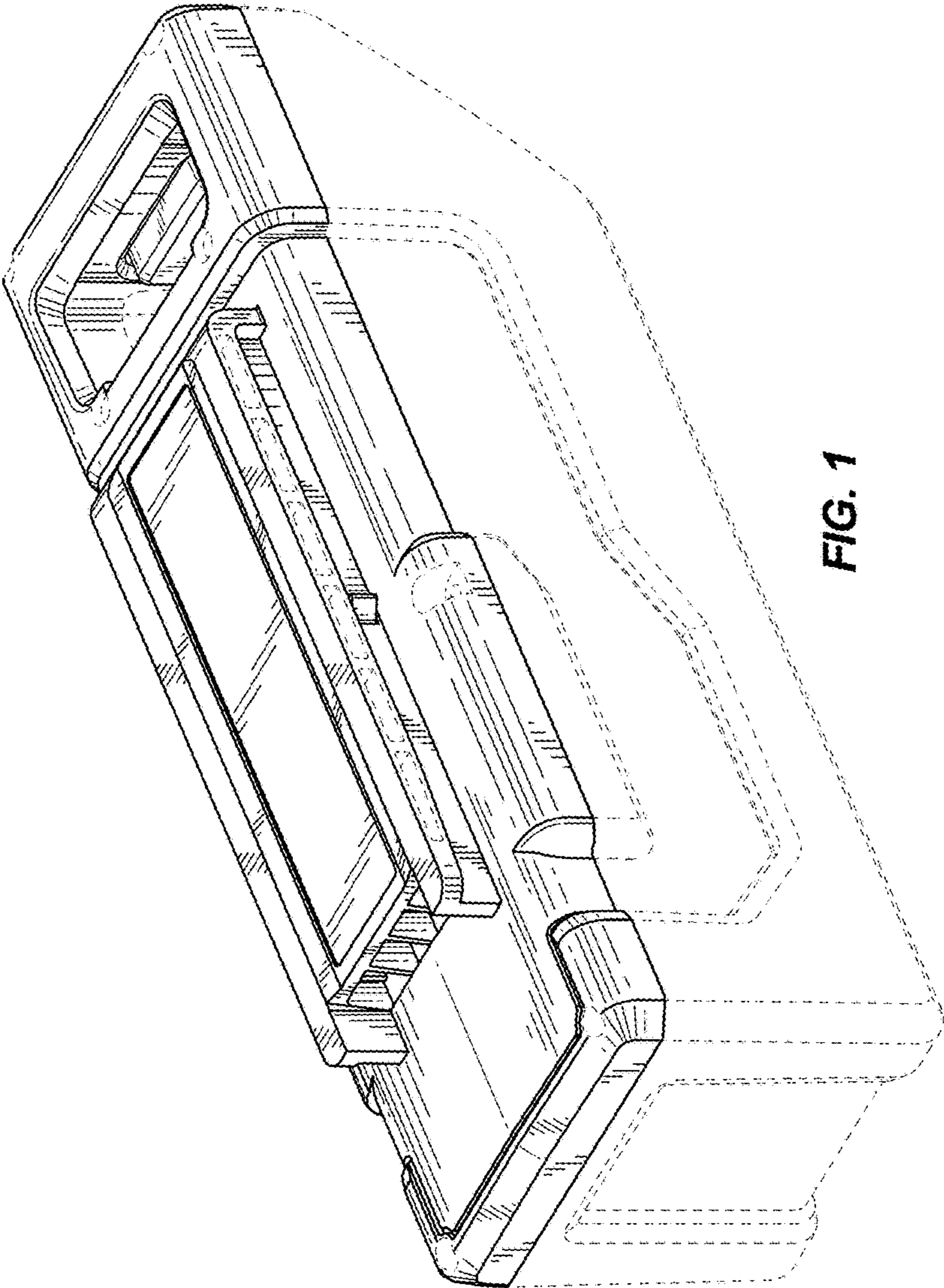

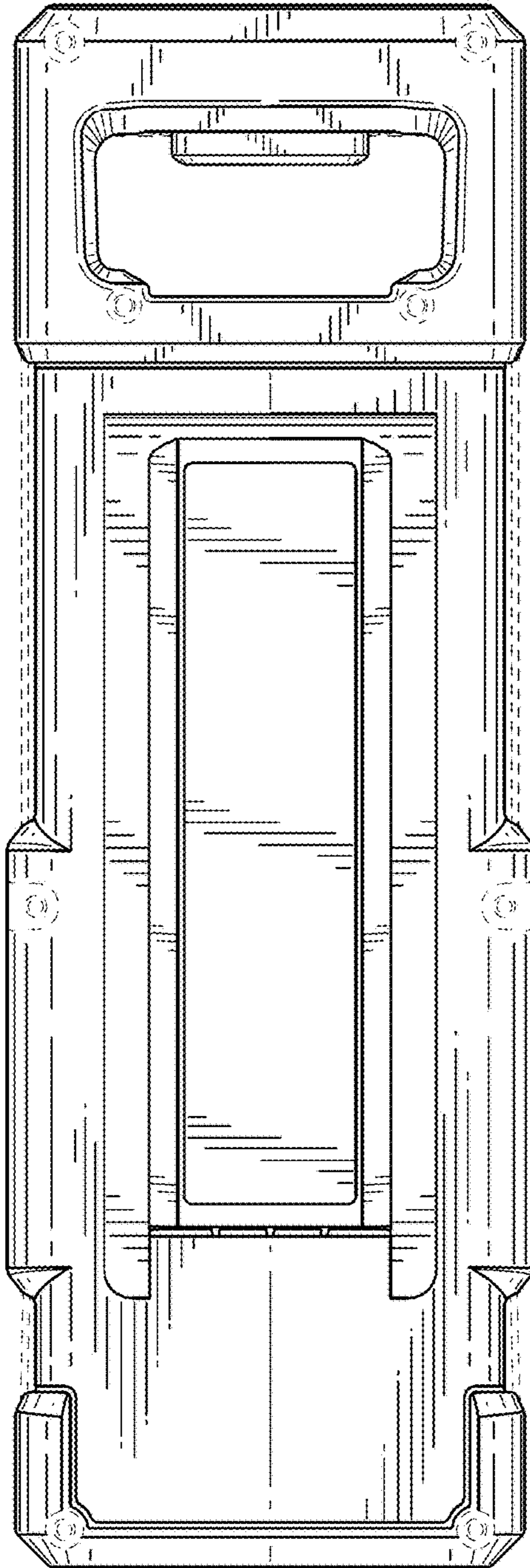

FIG. 2

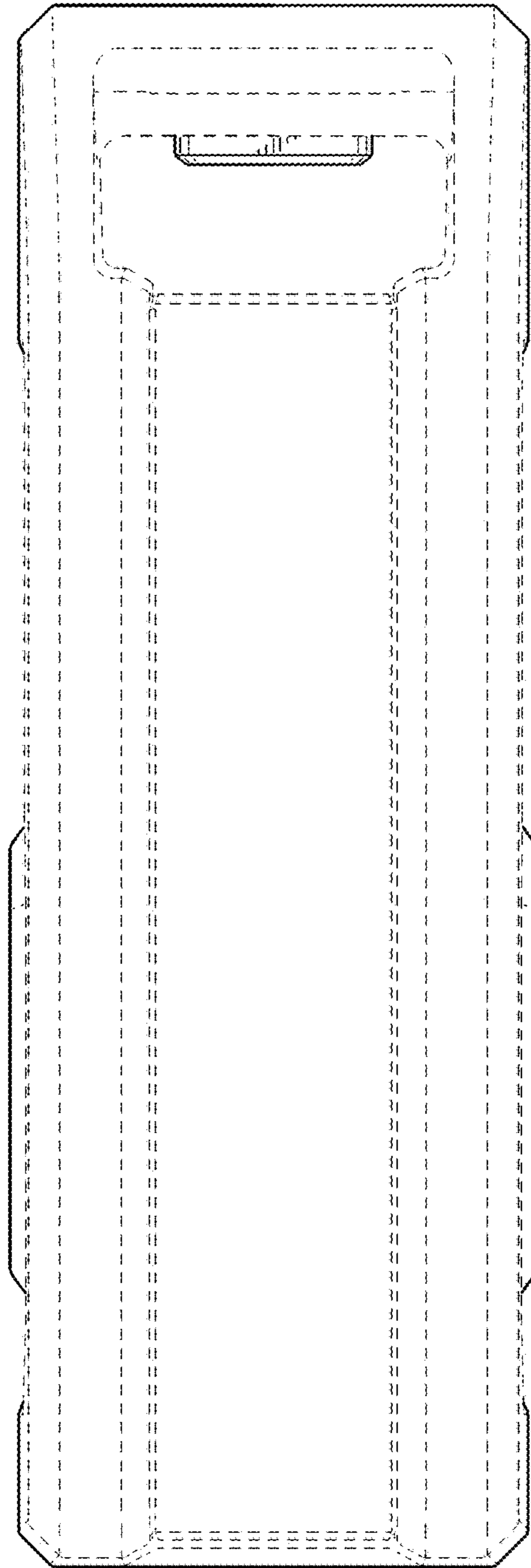

FIG. 3

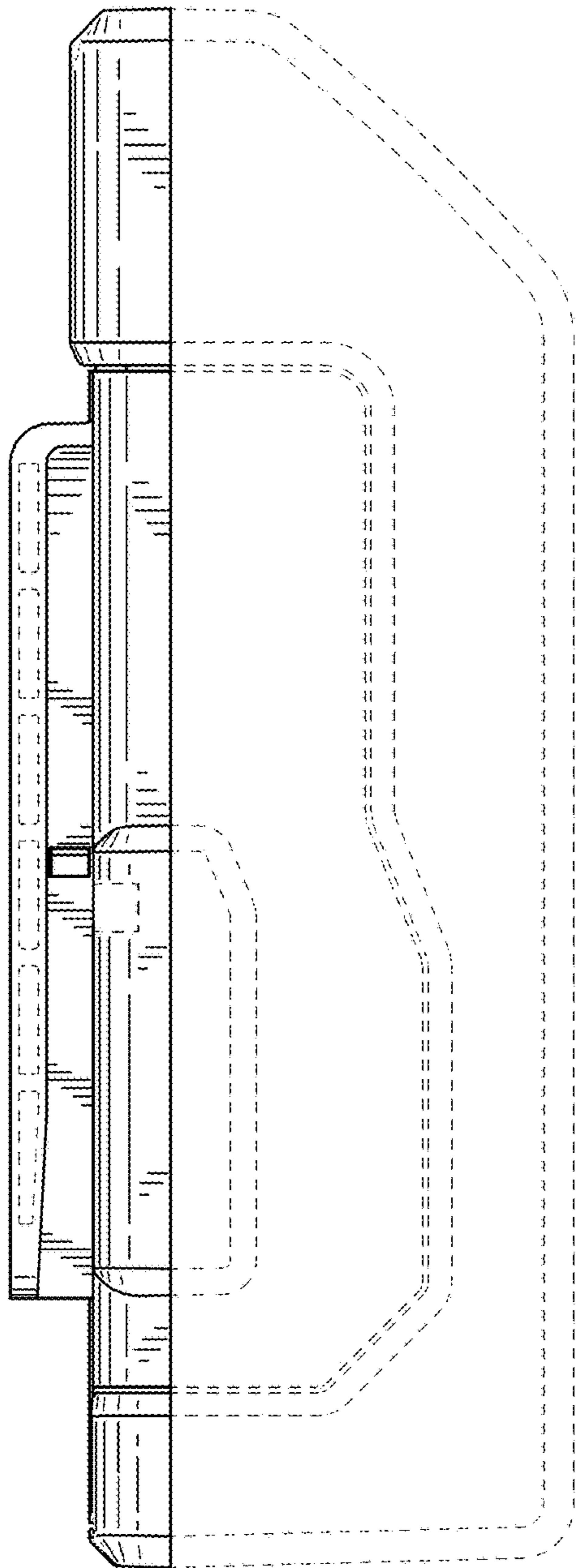

FIG. 4

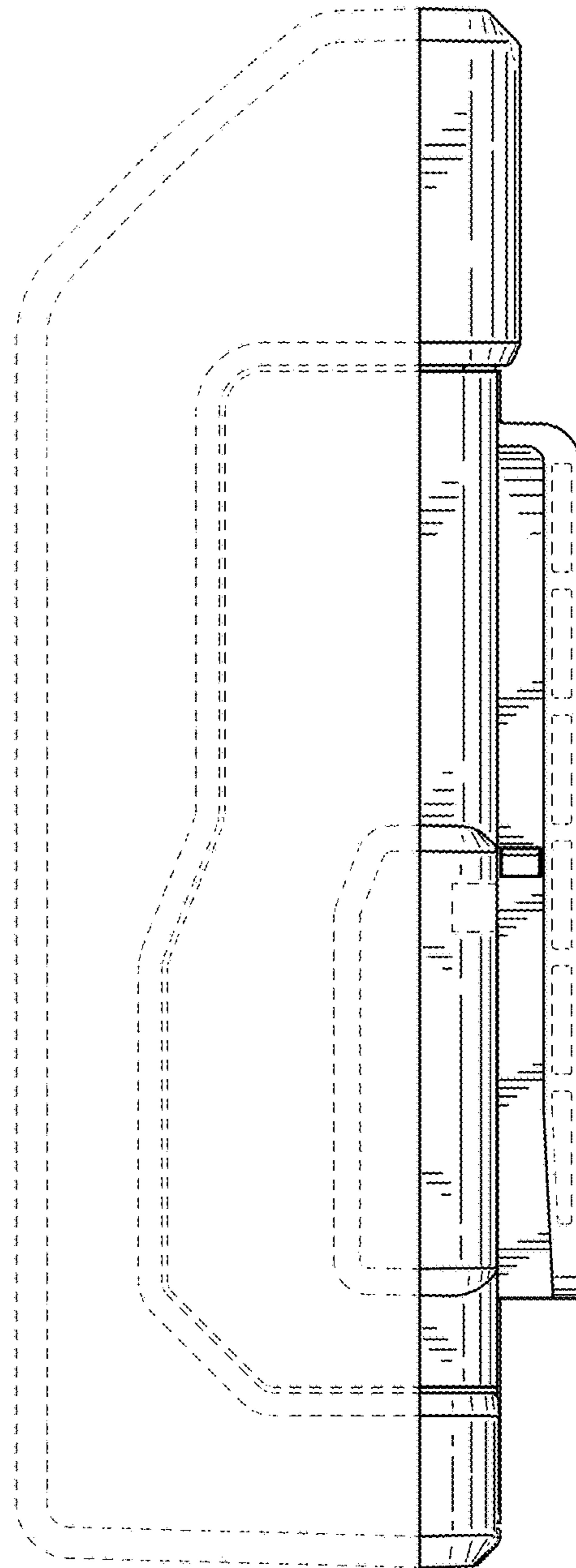

FIG. 5

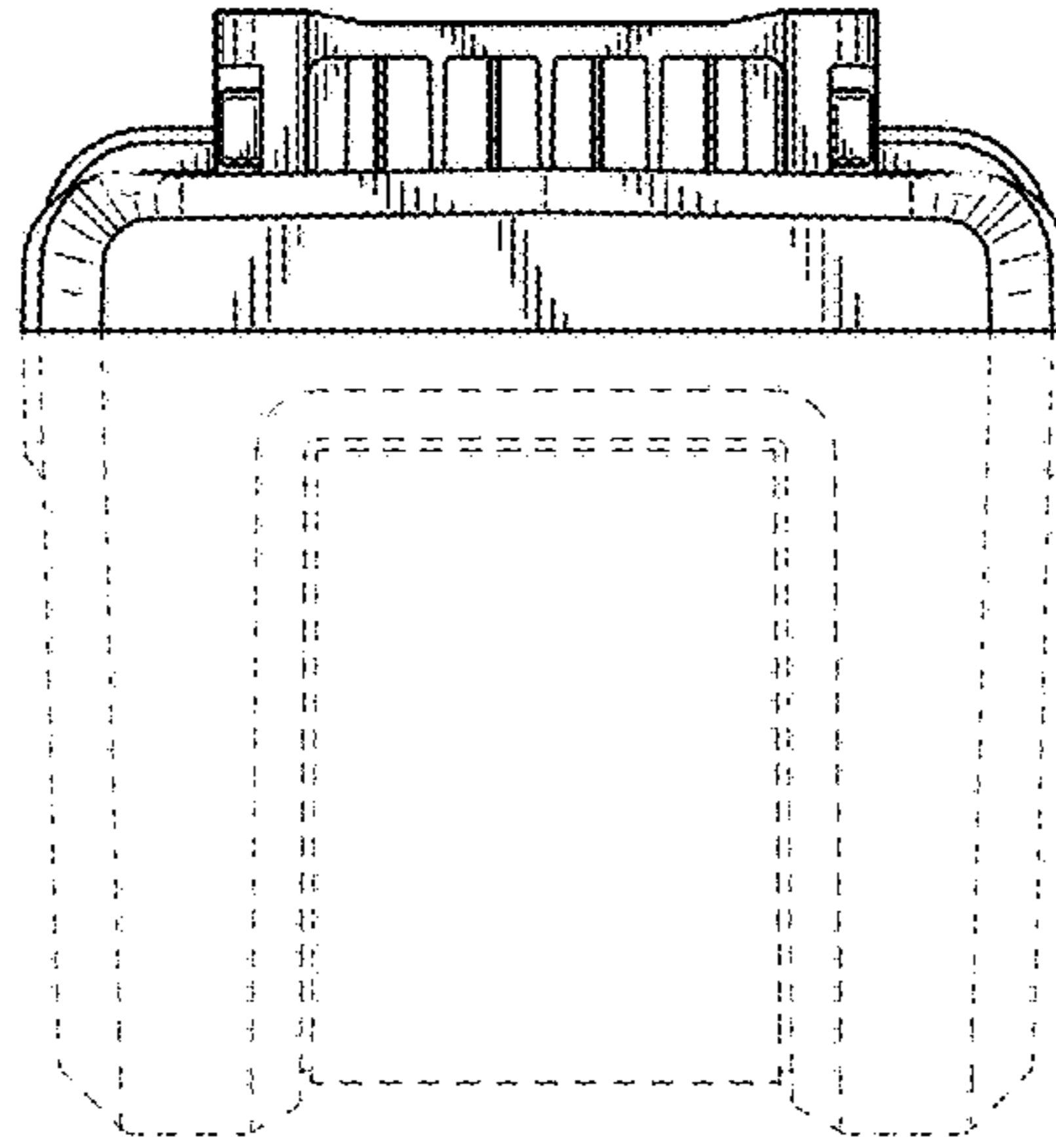

FIG. 6

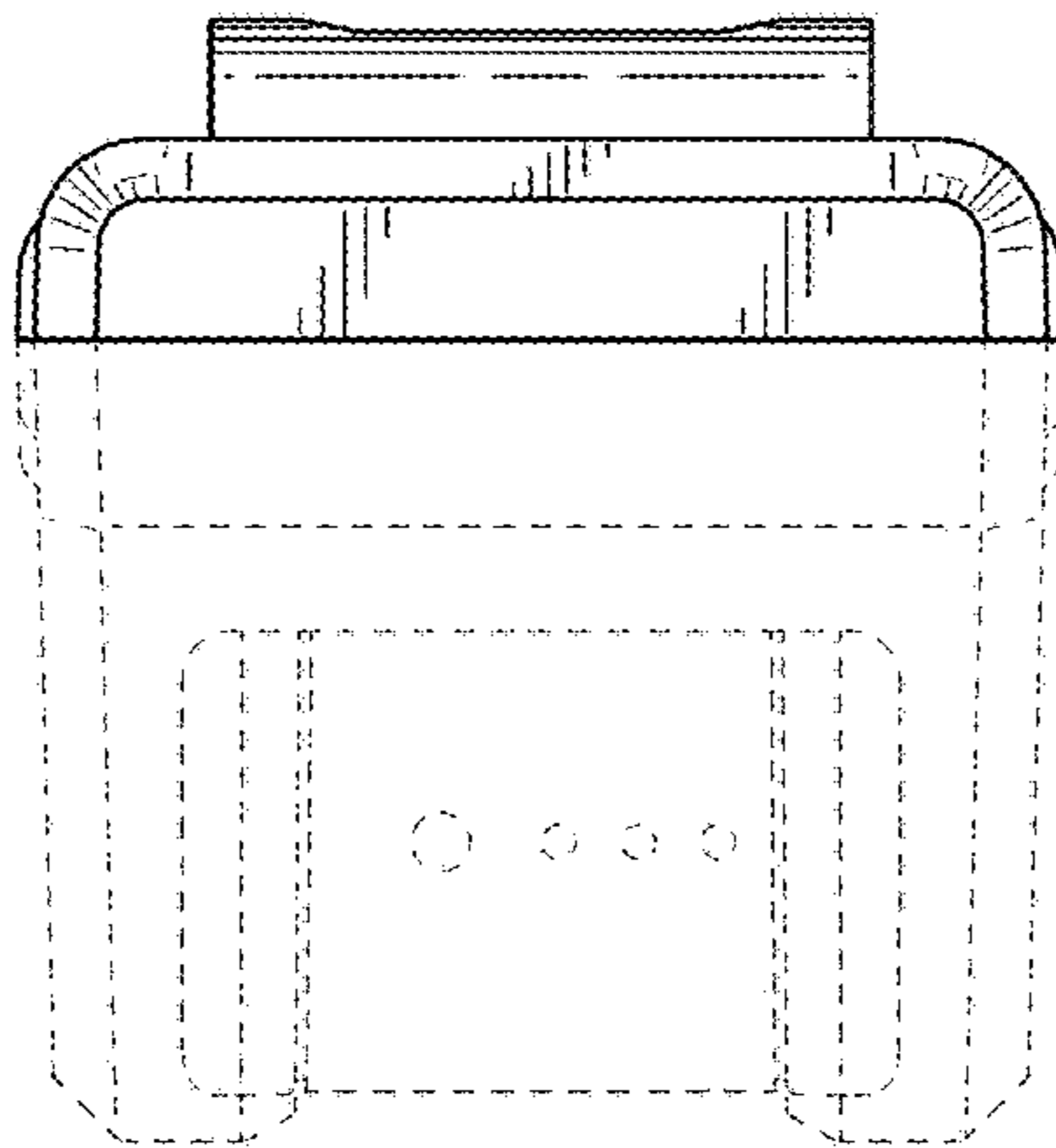

FIG. 7