



US00D793931S

(12) **United States Design Patent** (10) **Patent No.:** **US D793,931 S**
Lee et al. (45) **Date of Patent:** **** Aug. 8, 2017**

(54) **AUTOMOBILE INTERIOR**

(56) **References Cited**

(71) Applicants: **Inwoong Lee**, Rochester Hills, MI (US); **Chang-il Lee**, Detroit, MI (US); **Christopher A. Benjamin**, Clarkston, MI (US); **Klaus Busse**, Lake Orion, MI (US)

U.S. PATENT DOCUMENTS

D762,152 S *	7/2016	Inagaki	D12/192
D763,154 S *	8/2016	Chang	D12/192
D763,155 S *	8/2016	Sahs	D12/192
D770,348 S *	11/2016	Shimizu	D12/192
D770,953 S *	11/2016	Tanaka	D12/192
D771,541 S *	11/2016	Shouno	D12/192
D772,128 S *	11/2016	Platt	D12/192
D776,029 S *	1/2017	Callum	D12/192
D778,796 S *	2/2017	Gommier	D12/192
D778,797 S *	2/2017	Ito	D12/192
D780,649 S *	3/2017	Tanaka	D12/192

(72) Inventors: **Inwoong Lee**, Rochester Hills, MI (US); **Chang-il Lee**, Detroit, MI (US); **Christopher A. Benjamin**, Clarkston, MI (US); **Klaus Busse**, Lake Orion, MI (US)

* cited by examiner

(73) Assignee: **FCA US LLC**, Auburn Hills, MI (US)

Primary Examiner — Katrina A Betton

(**) Term: **15 Years**

(74) *Attorney, Agent, or Firm* — Ralph E Smith

(21) Appl. No.: **29/551,130**

(57) **CLAIM**

The ornamental design for an automobile interior, as shown and described.

(22) Filed: **Jan. 11, 2016**

DESCRIPTION

(51) **LOC (10) Cl.** **12-16**

(52) **U.S. Cl.**
USPC **D12/192**

(58) **Field of Classification Search**
USPC D12/192, 415, 110, 114; D15/17, 28;
D10/46, 98, 102-103, 122-127
CPC G08G 1/096883; G01C 21/16; G01C
21/3688; G01C 21/30

FIG. 1 is a front view of an automobile interior showing our new design;
FIG. 2 is a driver-side perspective view thereof;
FIG. 3 is a passenger-side perspective view thereof; and,
FIG. 4 is a top plan view.

It will be understood that the dashed lines presented in the drawings are for illustration only, and do not form a part of the claimed design.

See application file for complete search history.

1 Claim, 4 Drawing Sheets

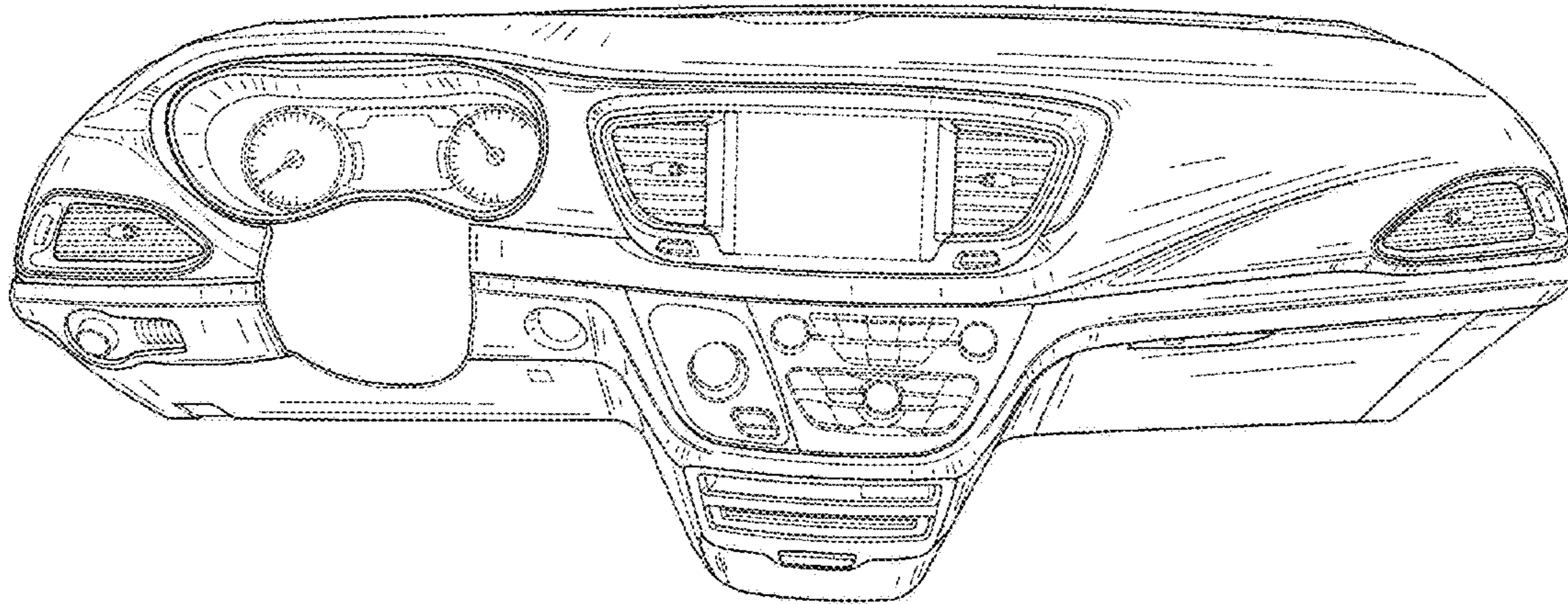

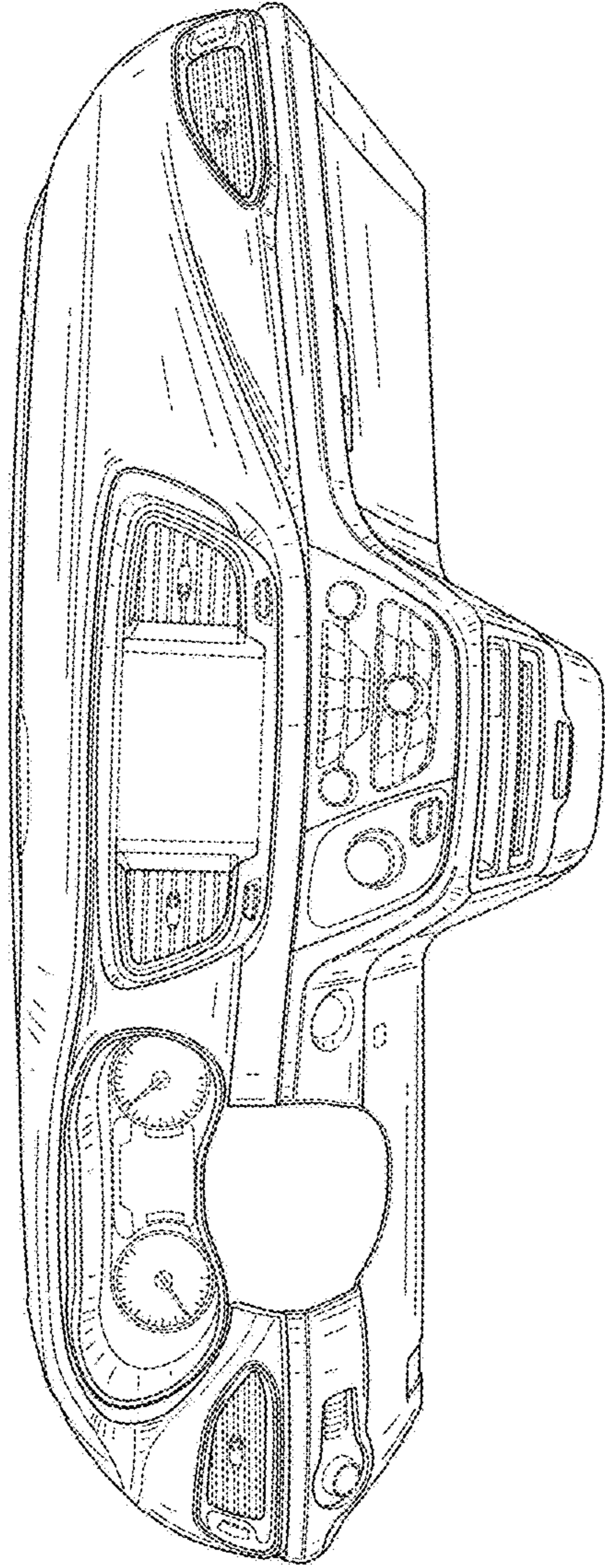

FIG. 1

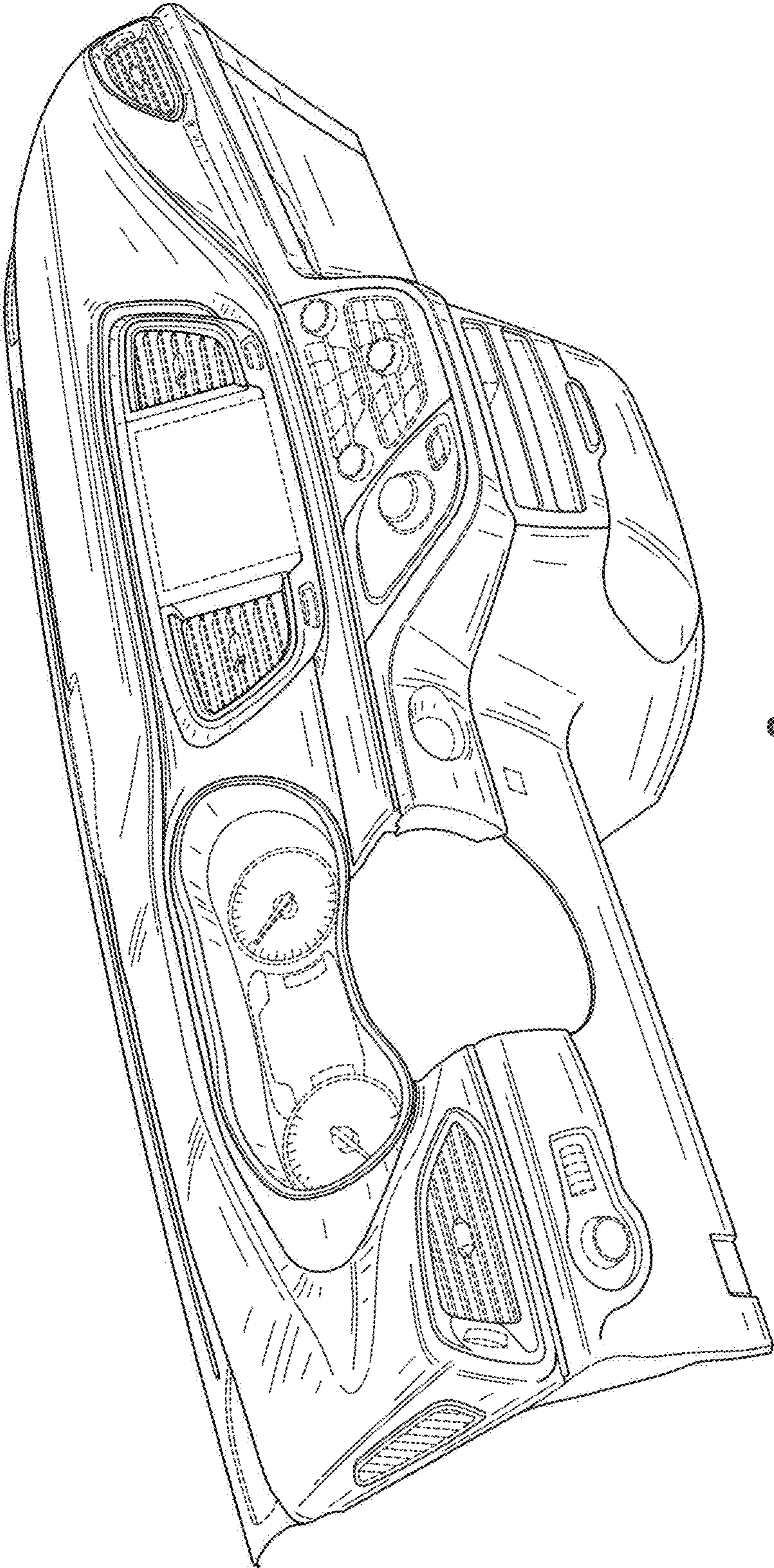

FIG. 2

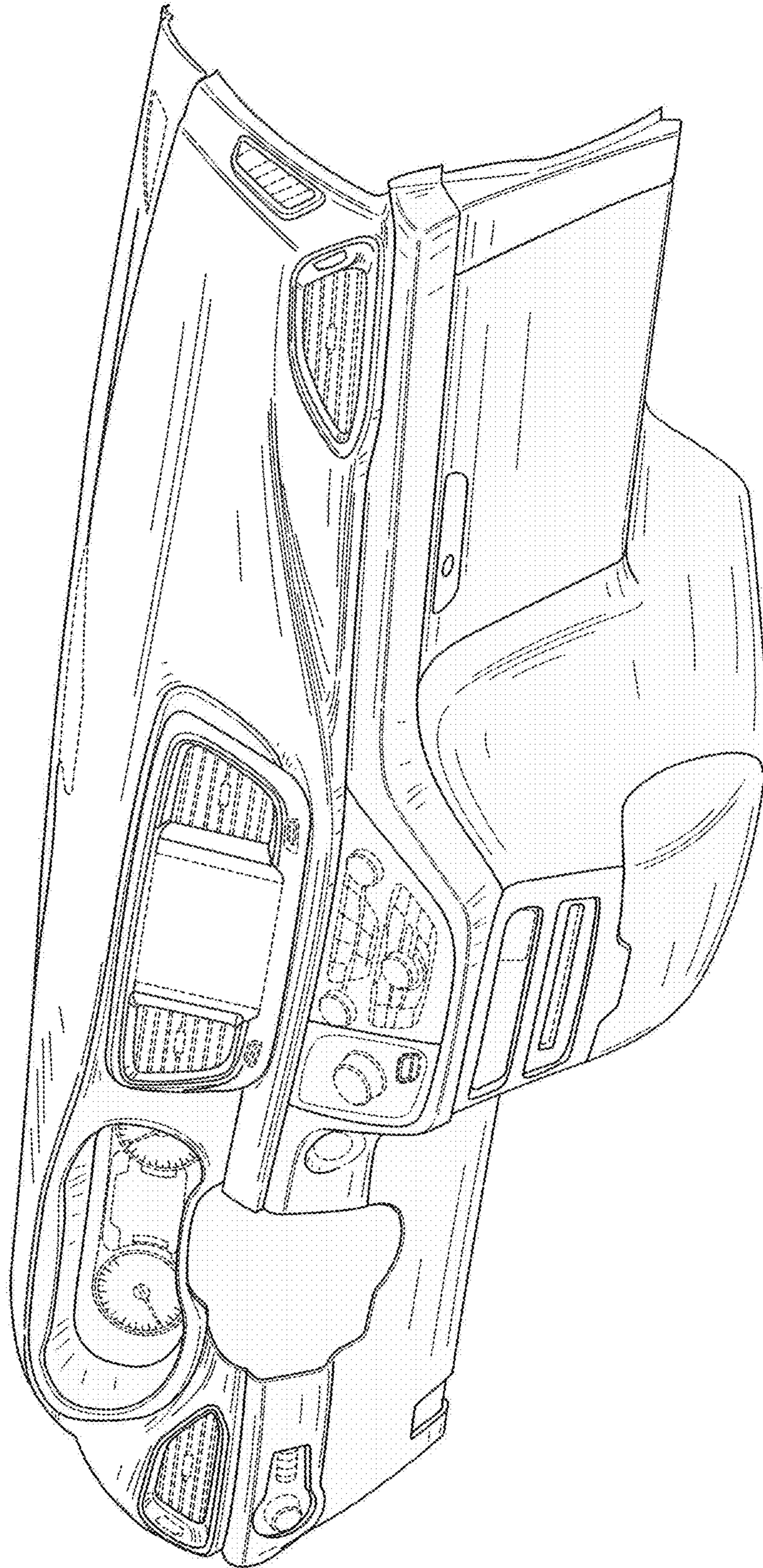

FIG. 3

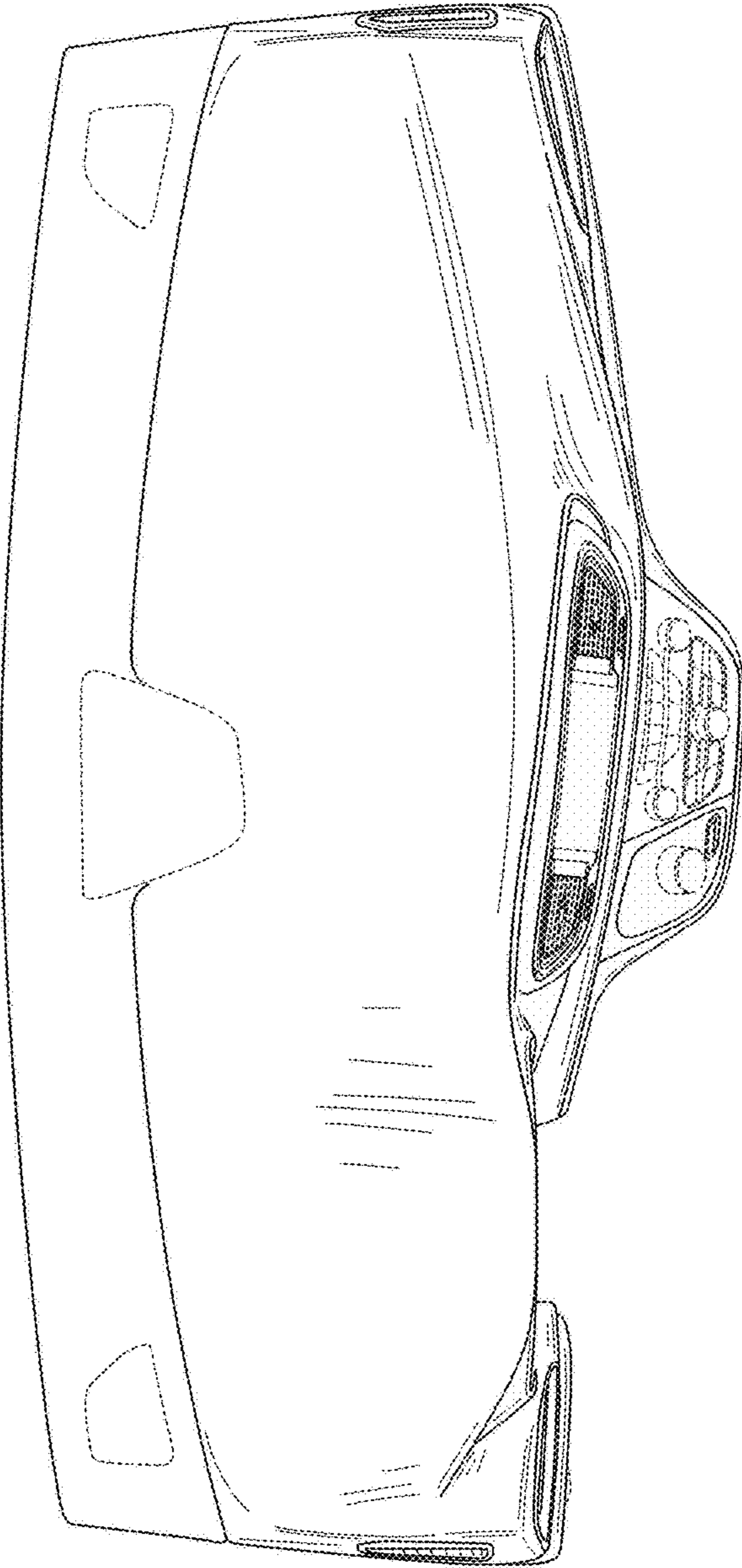

FIG. 4