



US00D793820S

(12) **United States Design Patent** (10) **Patent No.:** **US D793,820 S**
Semo et al. (45) **Date of Patent:** **** Aug. 8, 2017**

(54) **FOOD PRESS**

(71) Applicant: **Juicero, Inc.**, San Francisco, CA (US)
(72) Inventors: **Dan Semo**, San Francisco, CA (US);
John Kiechel, Oakland, CA (US); **Paul Katz**, San Marino, CA (US)
(73) Assignee: **Juicero, Inc.**, San Francisco, CA (US)
(**) Term: **15 Years**
(21) Appl. No.: **29/556,812**

(22) Filed: **Mar. 3, 2016**
(51) **LOC (10) Cl.** **07-04**
(52) **U.S. Cl.**
USPC **D7/665**
(58) **Field of Classification Search**
USPC D3/200, 201, 206, 316; D6/300, 302,
D6/542, 543, 544, 545, 668, 672;
D7/213, 300, 301, 305, 307, 308, 309,
D7/311, 368, 589, 665; D8/353;
D9/430, 432, 455; D14/341; D16/165;
D19/27, 32, 75; D25/2, 32
CPC A47J 43/286; A47J 19/02; A47J 19/06;
F16D 2125/66; A23N 1/00
See application file for complete search history.

(56) **References Cited**

U.S. PATENT DOCUMENTS

D416,797 S *	11/1999	Rabe	D9/431
D487,870 S *	3/2004	Stewart	D9/432
D550,270 S *	9/2007	Astill	D16/241
D673,950 S *	1/2013	Li	D14/341
D686,065 S *	7/2013	Kuo	D9/432
D738,664 S *	9/2015	Cha	D7/301
D769,045 S *	10/2016	Cha	D7/306
D777,030 S *	1/2017	Irimia	D9/432
2012/0085248 A1 *	4/2012	Lin	A47J 19/02
				99/501
2016/0095461 A1 *	4/2016	Desjardin	A47J 19/02
				99/513

OTHER PUBLICATIONS

The Juicero Press. Home Page, Publication date unknown, [site visited Mar. 28, 2017], Available on the Internet URL: <www.juicero.com>.*
The Juicero Press. The Press, Publication date unknown, [site visited Mar. 28, 2017], Available on the Internet URL: <www.juicero.com/the-press/>.*
YouTube video by Juciero, Juicero: Making Juice is Easy, Mar. 31, 2016, [site visited Mar. 28, 2017], Available on the Internet URL: <https://www.youtube.com/watch?v=X1oHp-VvhDE>.*
U.S. Appl. No. 29/556,819, filed Mar. 3, 2016, Semo et al.
U.S. Appl. No. 29/556,823, filed Mar. 3, 2016, Semo et al.

* cited by examiner

Primary Examiner — Karen S. Acker
Assistant Examiner — S. Bryan Reinholdt, Jr.
(74) *Attorney, Agent, or Firm* — Wolf, Greenfield & Sacks, P.C.

(57) **CLAIM**

The ornamental design for a food press, as shown and described.

DESCRIPTION

FIG. 1 is a top, front, right side perspective view of a food press showing our new design;
FIG. 2 is a front elevation view thereof;
FIG. 3 is a rear elevation view thereof;
FIG. 4 is a left side elevation view thereof;
FIG. 5 is a right side elevation view thereof;
FIG. 6 is a top plan view thereof; and,
FIG. 7 is a bottom plan view thereof.
The dash-dash broken lines represent portions of the food press that form no part of the claimed design. The dot-dash broken lines represent boundaries of the claimed design and form no part of the claimed design.

1 Claim, 7 Drawing Sheets

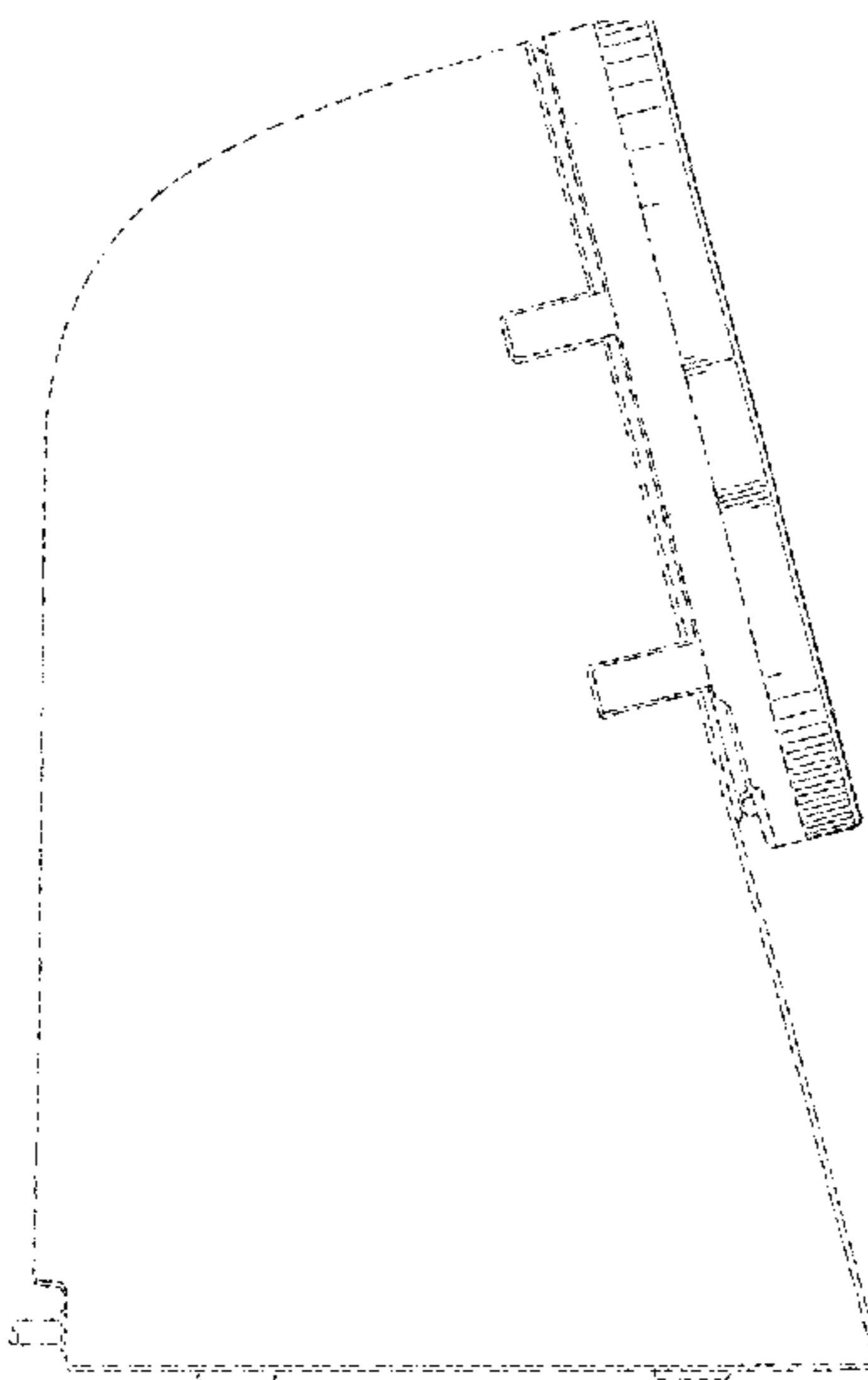
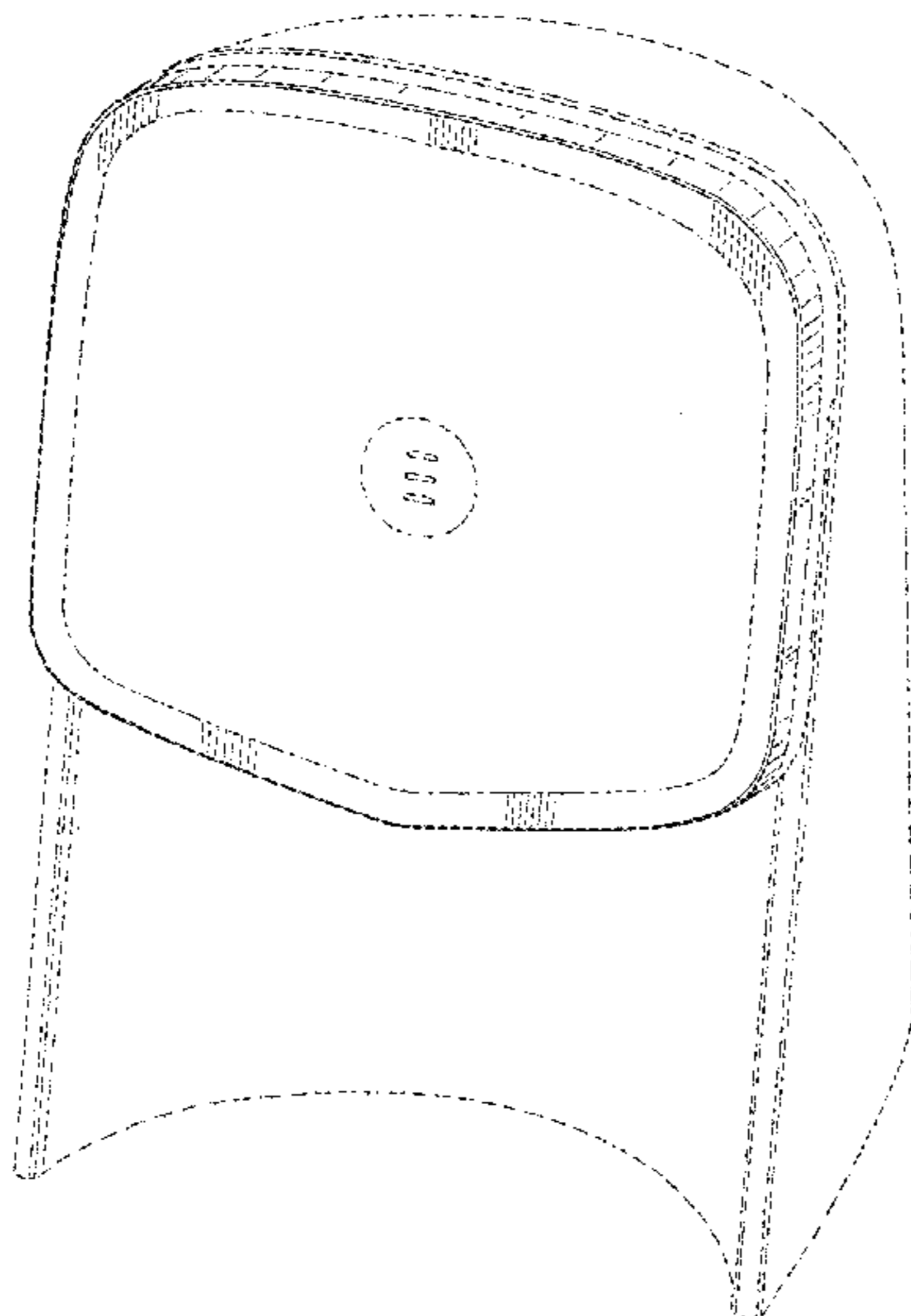

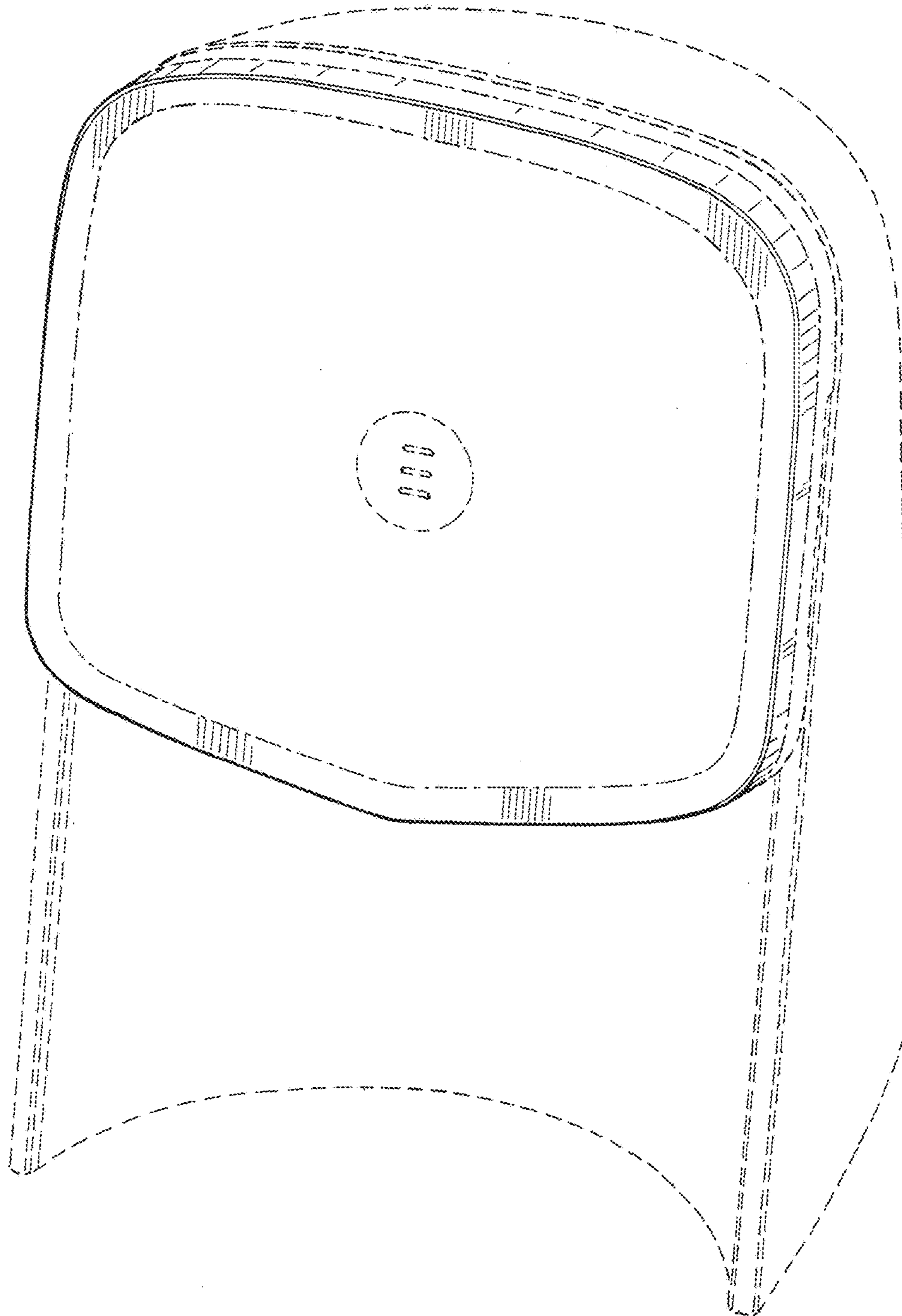

Fig. 1

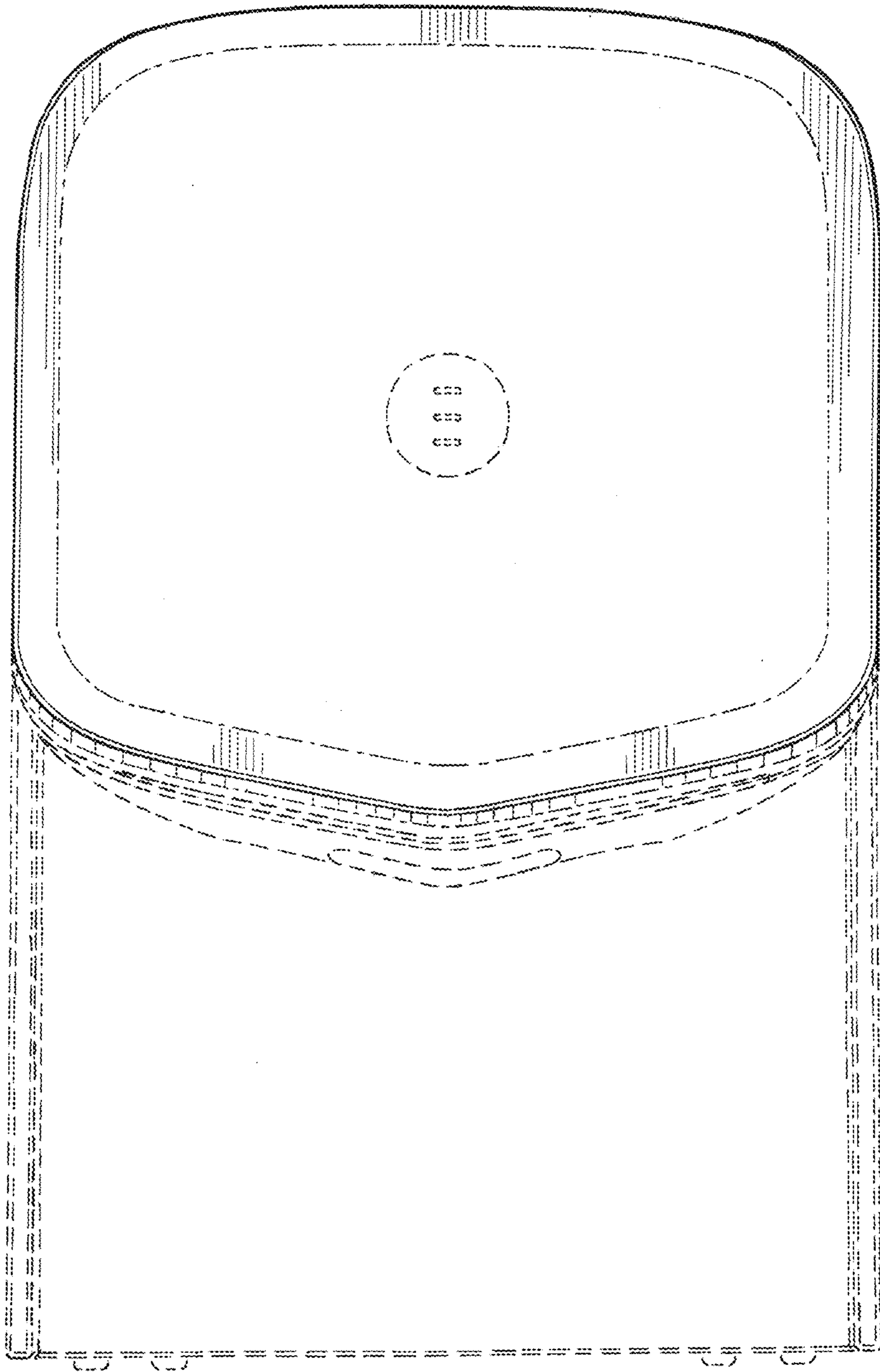

Fig. 2

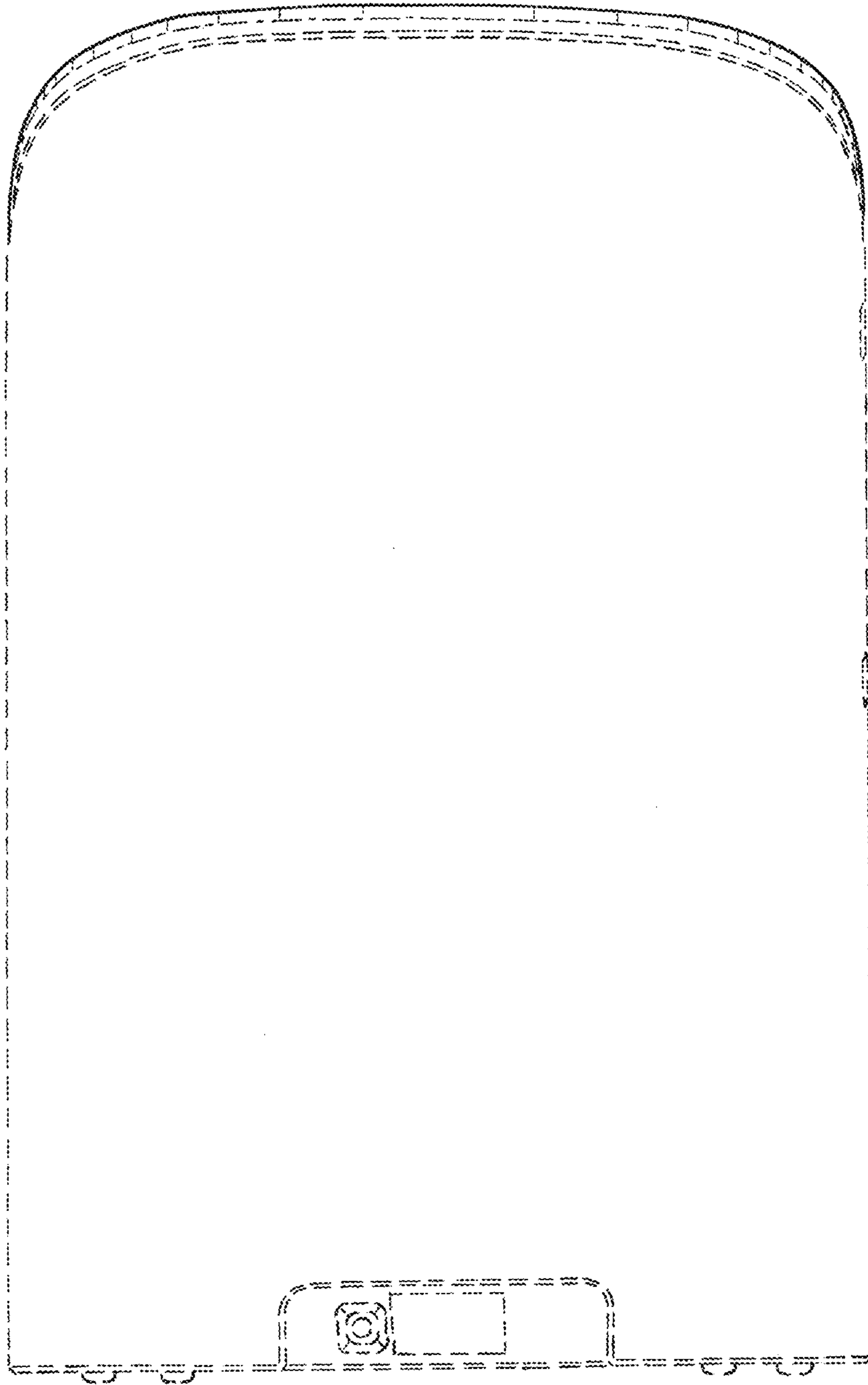

Fig. 3

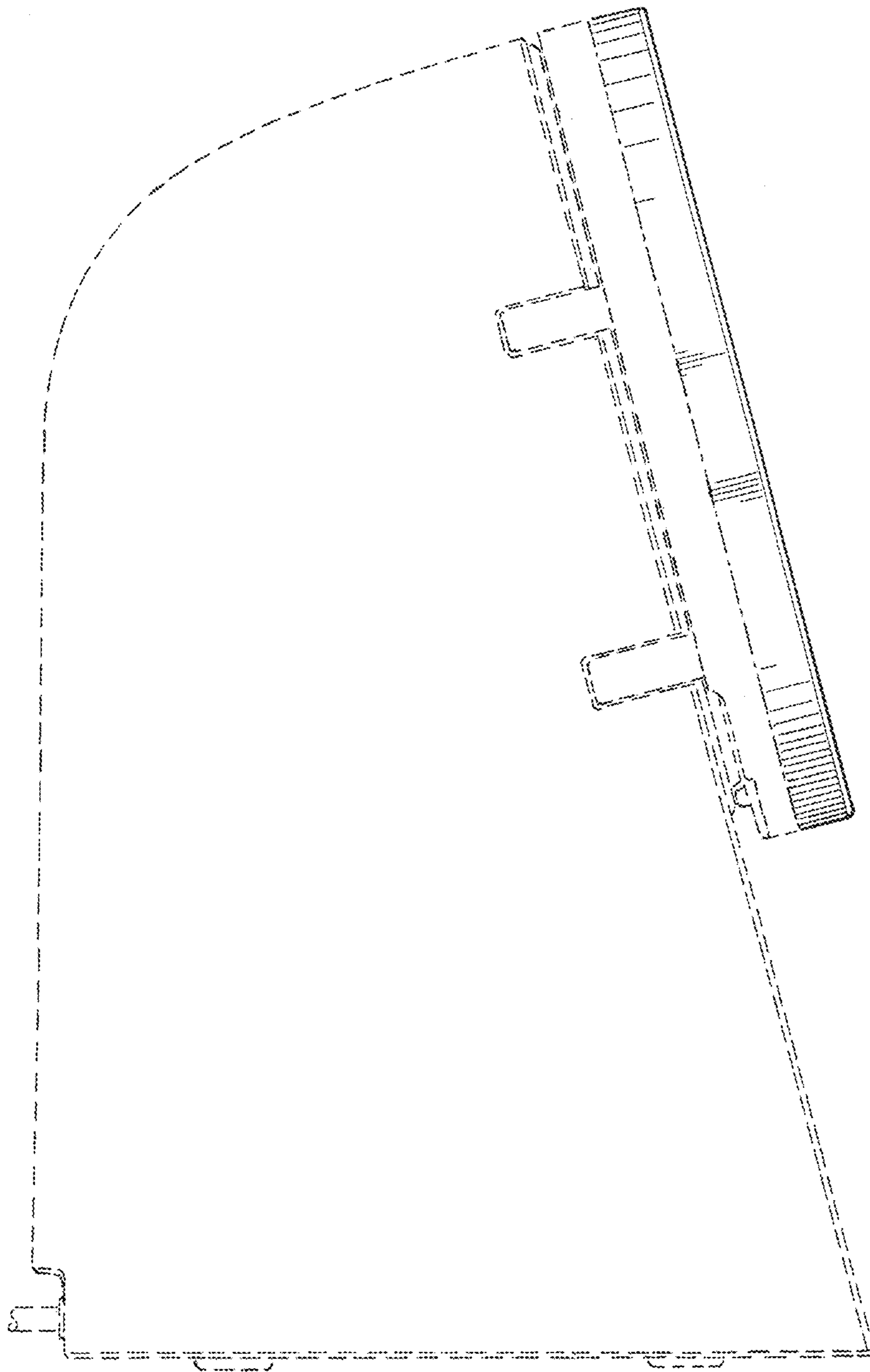

Fig. 4

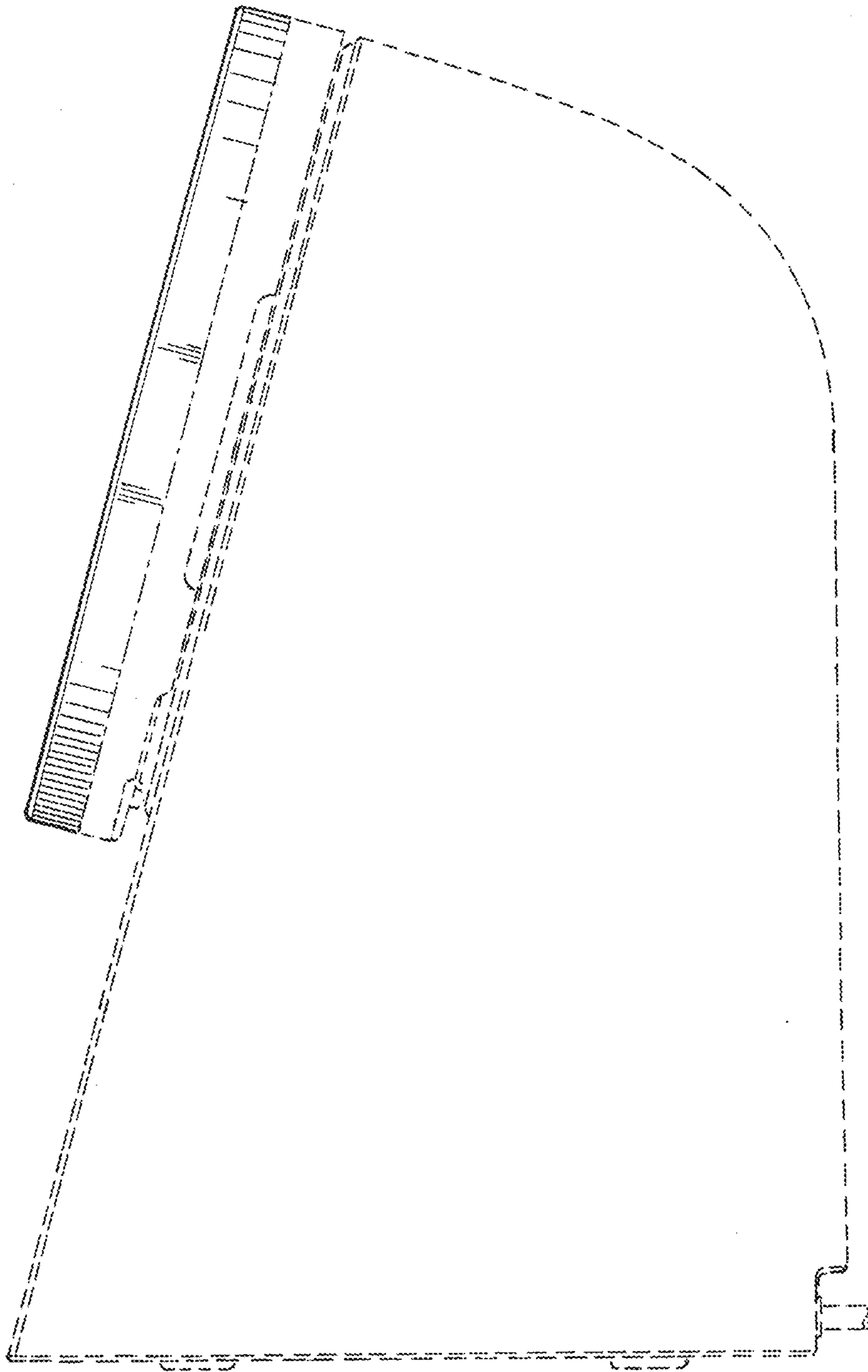

Fig. 5

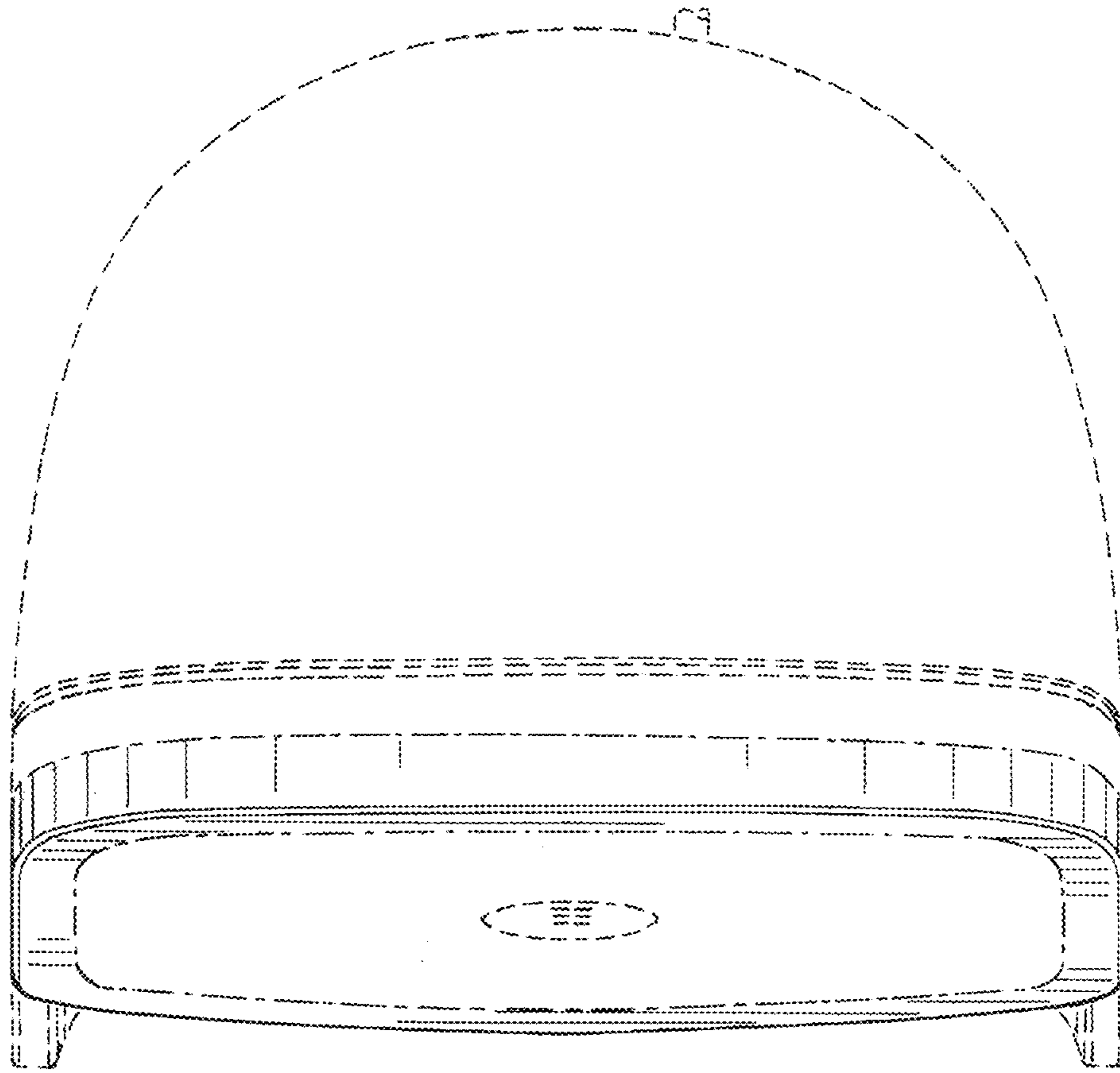

Fig. 6

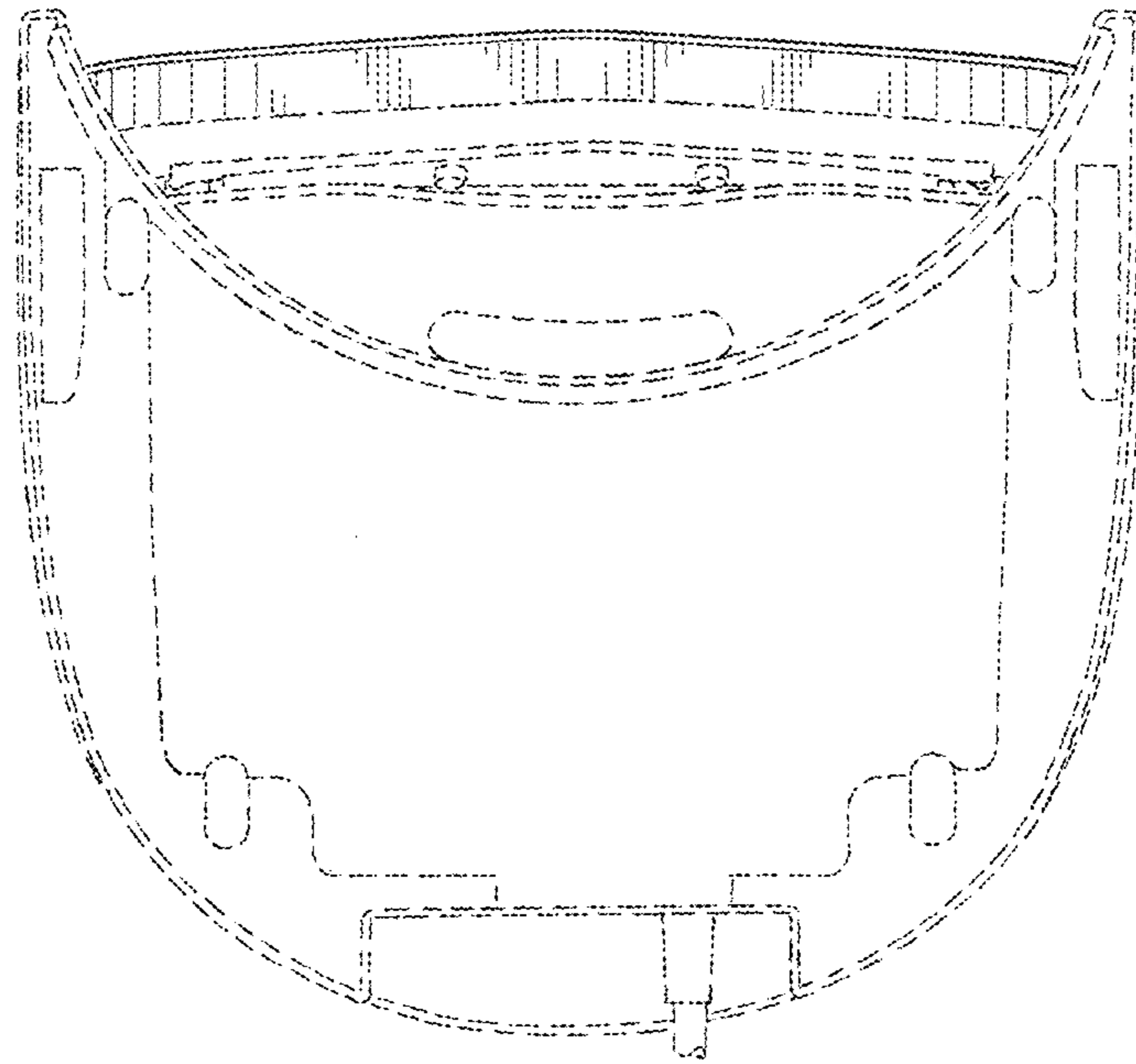

Fig. 7