



US00D793201S

(12) **United States Design Patent** (10) **Patent No.:** **US D793,201 S**  
**Carvell et al.** (45) **Date of Patent:** **\*\* Aug. 1, 2017**

- (54) **SPOOL HANDLE**
- (71) Applicants: **Kevin Carvell**, Ephrata, PA (US); **Steve Schreiber**, Ephrata, PA (US)
- (72) Inventors: **Kevin Carvell**, Ephrata, PA (US); **Steve Schreiber**, Ephrata, PA (US)
- (\*\*) Term: **15 Years**
- (21) Appl. No.: **29/558,859**
- (22) Filed: **Mar. 22, 2016**
- (51) **LOC (10) Cl.** ..... **08-06**
- (52) **U.S. Cl.**  
USPC ..... **D8/315**
- (58) **Field of Classification Search**  
USPC ..... D8/315; 15/144.3; 16/430  
CPC .. A01B 1/02; A01B 1/20; B25F 5/026; B25G 1/04  
See application file for complete search history.

D703,814 S *	4/2014	Bolia	.....	D24/133
D703,815 S *	4/2014	Bolia	.....	D24/133
D704,335 S *	5/2014	Bolia	.....	D24/133
2007/0114350 A1 *	5/2007	Sorci	.....	F16B 45/00 248/304
2009/0224110 A1 *	9/2009	Donowho	.....	H02G 3/0456 248/65
2010/0299855 A1 *	12/2010	Megeath	.....	A46B 5/025 15/22.1
2015/0373895 A1 *	12/2015	Bartnik	.....	A01B 1/02 56/400.04

\* cited by examiner

*Primary Examiner* — Caron D Veynar  
*Assistant Examiner* — Maria Edwards  
(74) *Attorney, Agent, or Firm* — Steve O'Donnell

(57) **CLAIM**

We claim the ornamental design for a spool handle, as shown.

**DESCRIPTION**

FIG. 1 is a front elevation view of our new design for a spool handle.  
FIG. 2 is a perspective view of our new design for a spool handle.  
FIG. 3 is a side elevation of our new design for a spool handle; and,  
FIG. 4 is another perspective view of our new design for a spool handle with dashed lines showing it in context with a spool.  
The broken line showing of a spool is included for the purpose of illustrating environmental structure and forms no part of the claimed design.

**1 Claim, 4 Drawing Sheets**

(56) **References Cited**

U.S. PATENT DOCUMENTS

D258,342 S *	2/1981	Boulis	.....	D23/403
D341,071 S *	11/1993	Prusak	.....	D8/300
5,920,944 A *	7/1999	Biggs	.....	B25G 1/04 15/143.1
D424,901 S *	5/2000	Landry	.....	D8/107
D424,905 S *	5/2000	Sankuer	.....	D8/14
D483,799 S *	12/2003	Kadota	.....	D18/40
D509,414 S *	9/2005	Hinden	.....	D8/13
D546,147 S *	7/2007	Cullen	.....	D8/16
D559,079 S *	1/2008	Berry	.....	D8/343
8,082,619 B1 *	12/2011	Willey	.....	A46B 5/02 15/143.1
8,375,499 B1 *	2/2013	Marino	.....	B25G 1/102 15/143.1

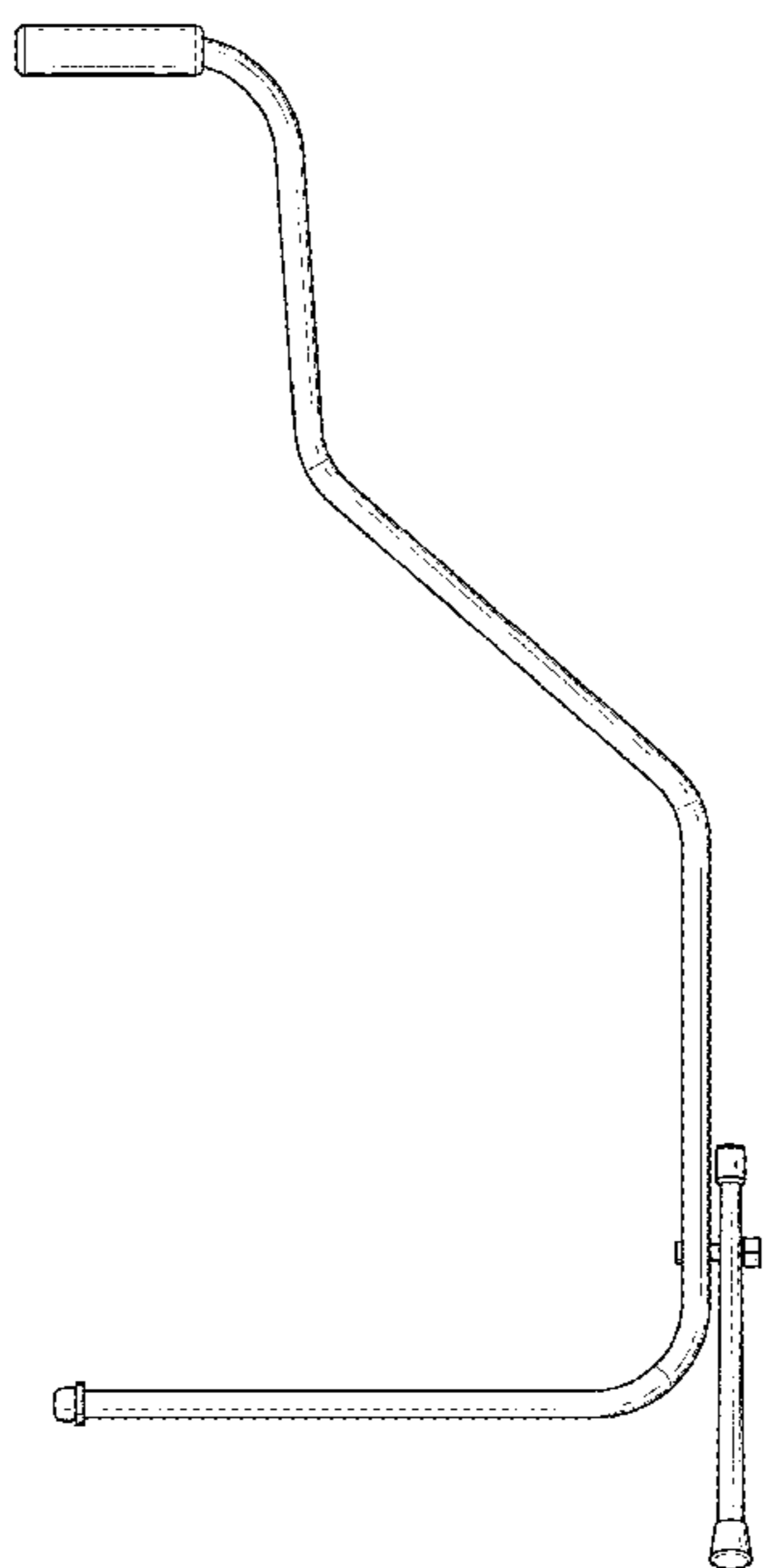

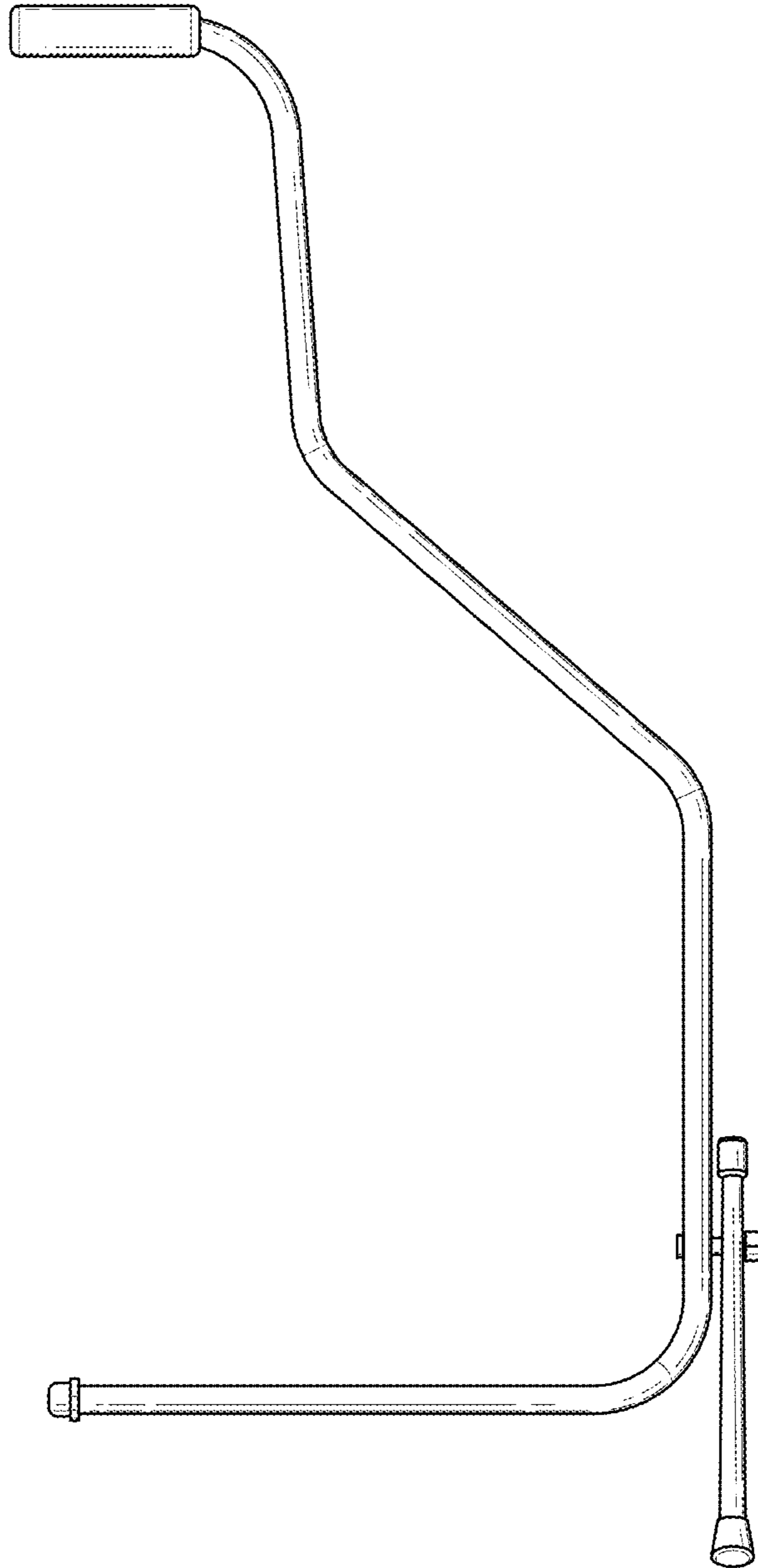

FIG. 1

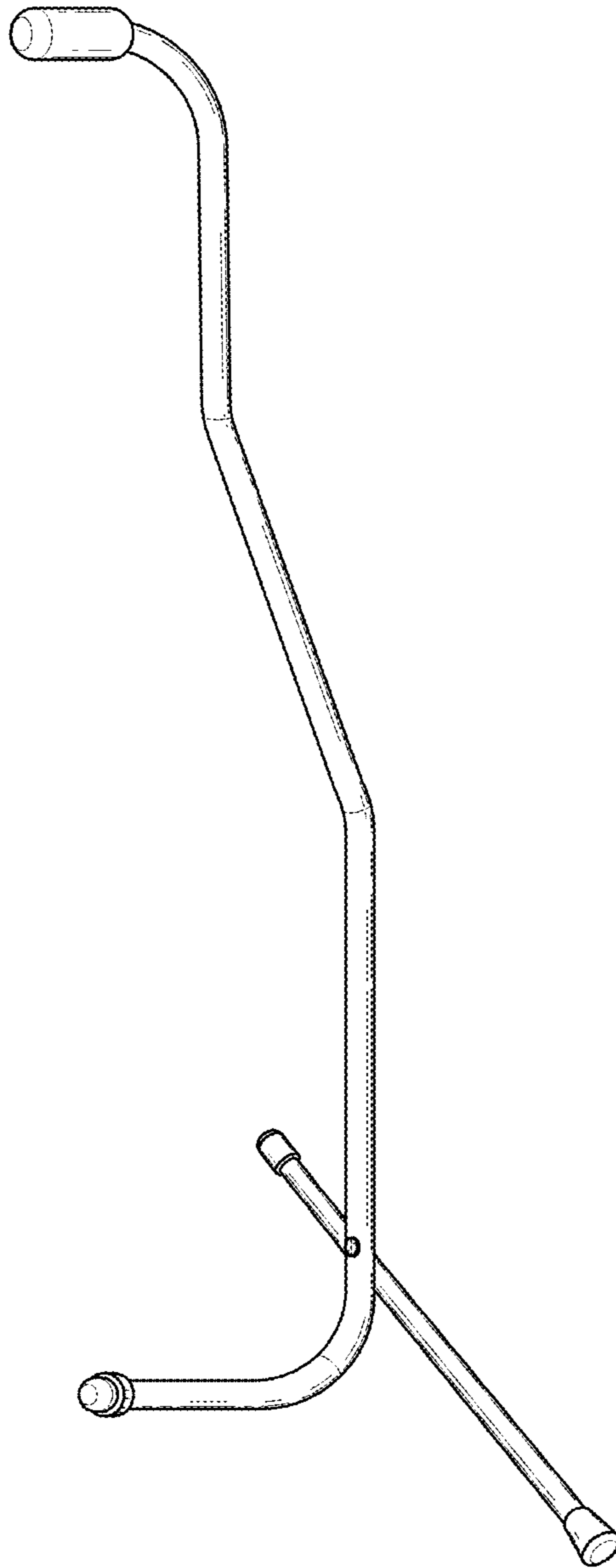

FIG. 2

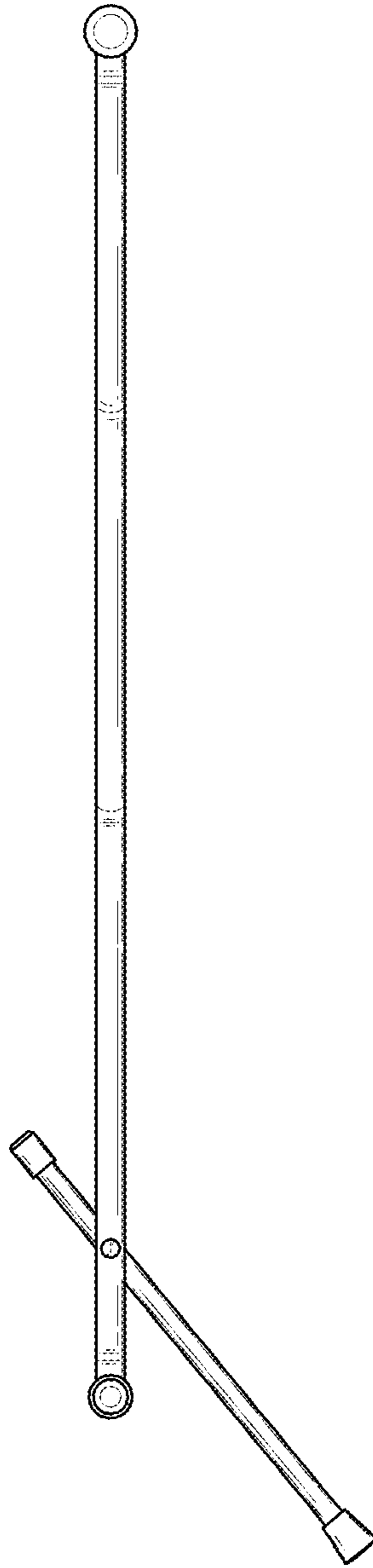

FIG. 3

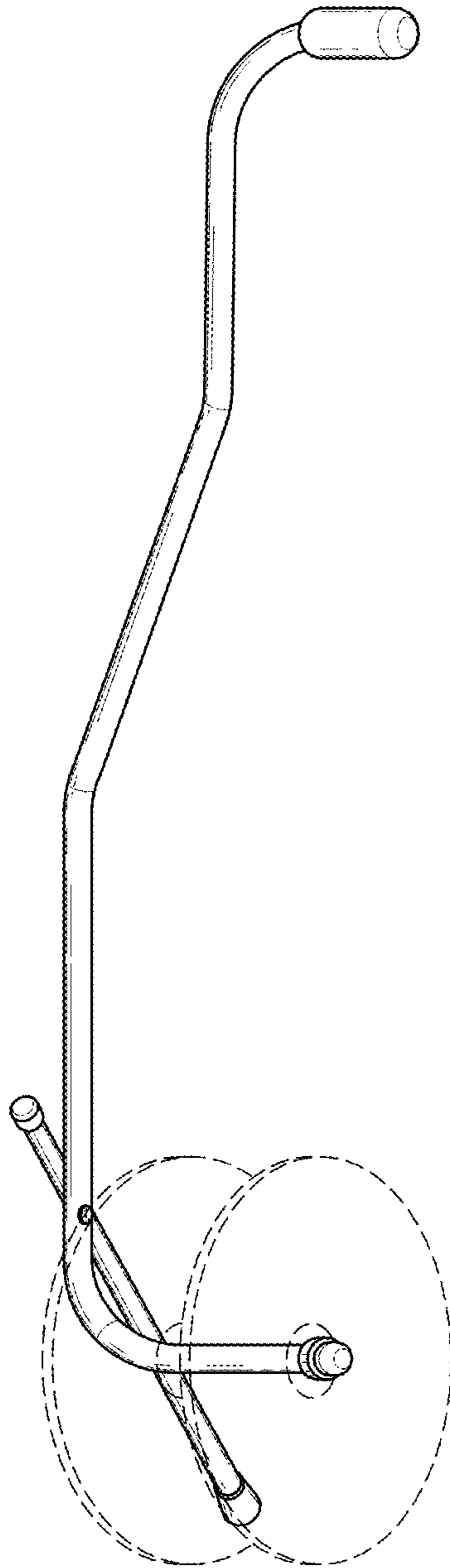

FIG. 4