



US00D792991S

(12) **United States Design Patent** (10) **Patent No.:** **US D792,991 S**
Wu (45) **Date of Patent:** **** Jul. 25, 2017**

(54) **VEHICLE TAILLIGHT**
(71) Applicant: **COPLUS INC.**, Tainan (TW)
(72) Inventor: **Po-Hua Wu**, Tainan (TW)
(73) Assignee: **Coplus Inc.**, Tainan (TW)
(**) Term: **15 Years**
(21) Appl. No.: **29/559,900**
(22) Filed: **Mar. 31, 2016**
(51) **LOC (10) Cl.** **26-06**
(52) **U.S. Cl.**
USPC **D26/28**
(58) **Field of Classification Search**
USPC D26/28-36; 362/80-83, 267-269,
362/459-468, 475-478, 485-487
CPC F21S 48/00; F21S 48/10; F21S 48/115;
F21S 48/225; F21S 48/1233; F21S
48/1266; F21S 48/1388; F21S 48/2268;
F21V 21/04
See application file for complete search history.

D532,537 S * 11/2006 Shiu D26/39
D564,683 S * 3/2008 Roach D26/28
D570,011 S * 5/2008 Huang D26/28
D638,963 S * 5/2011 Huang D26/28

* cited by examiner

Primary Examiner — Marcus Jackson
(74) *Attorney, Agent, or Firm* — Lewis Roca Rothgerber
Christie LLP

(57) **CLAIM**

The ornamental design for a vehicle tail light, as shown and described.

DESCRIPTION

FIG. 1 is a perspective view of the vehicle tail light;
FIG. 2 is a front view thereof;
FIG. 3 is a rear view thereof;
FIG. 4 is a left side view thereof;
FIG. 5 is a right side view thereof;
FIG. 6 is a top view thereof; and,
FIG. 7 is a bottom view thereof.
The broken lines in the drawings are for illustrative purpose only and form no part of the claimed design.

(56) **References Cited**

U.S. PATENT DOCUMENTS

D490,172 S * 5/2004 Yamamoto D26/28
D521,162 S * 5/2006 Campagna D26/28

1 Claim, 4 Drawing Sheets

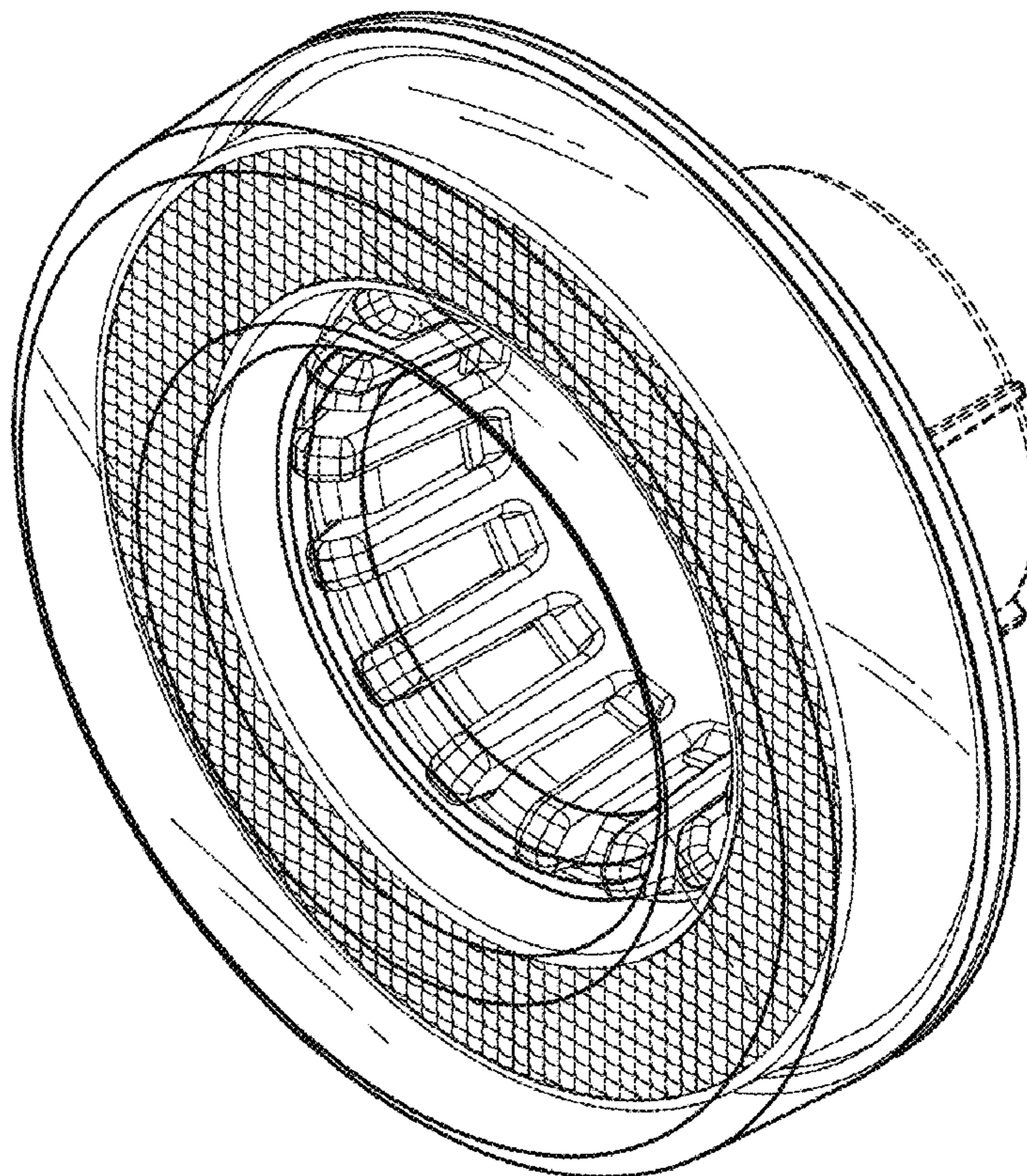

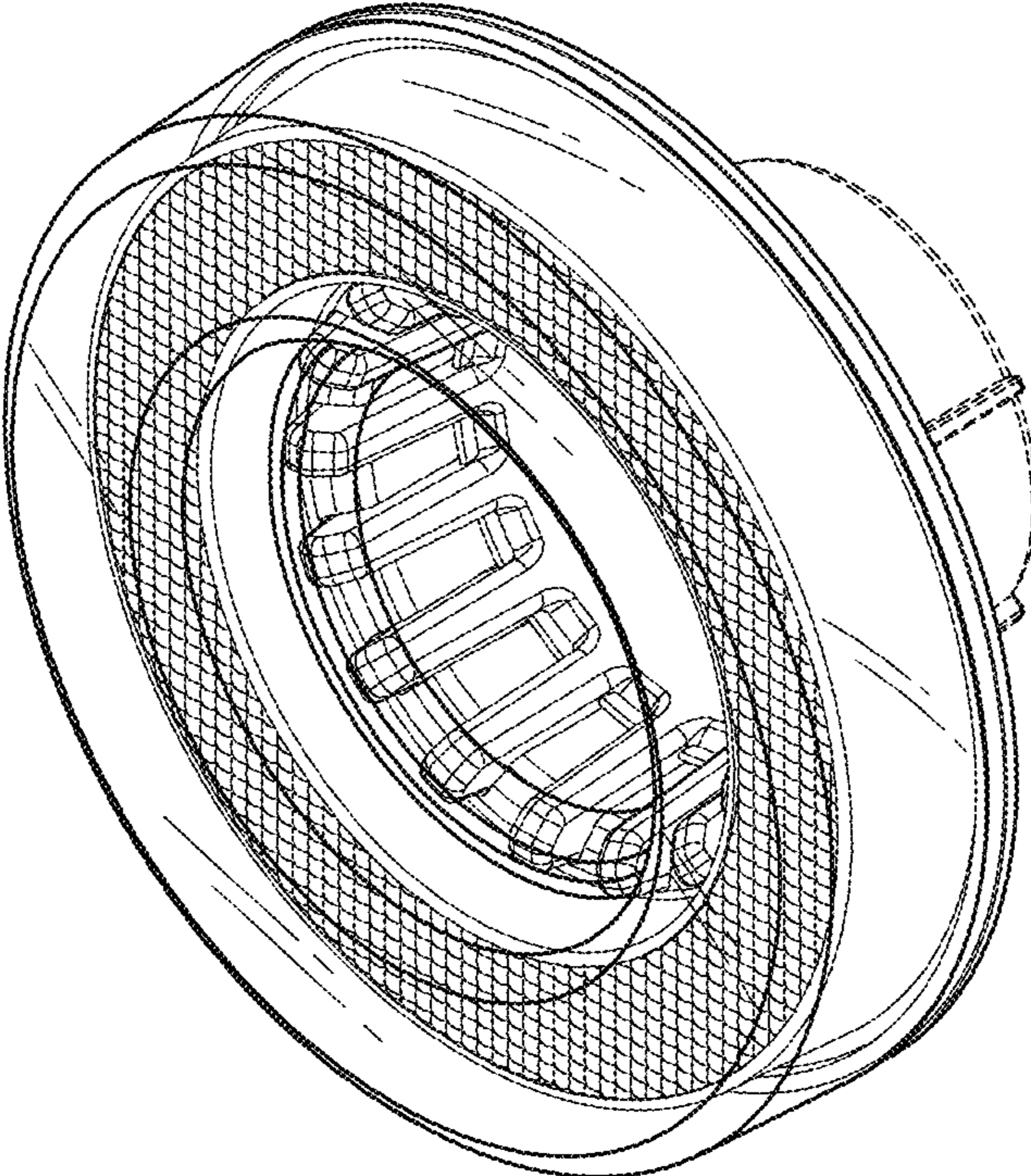

FIG. 1

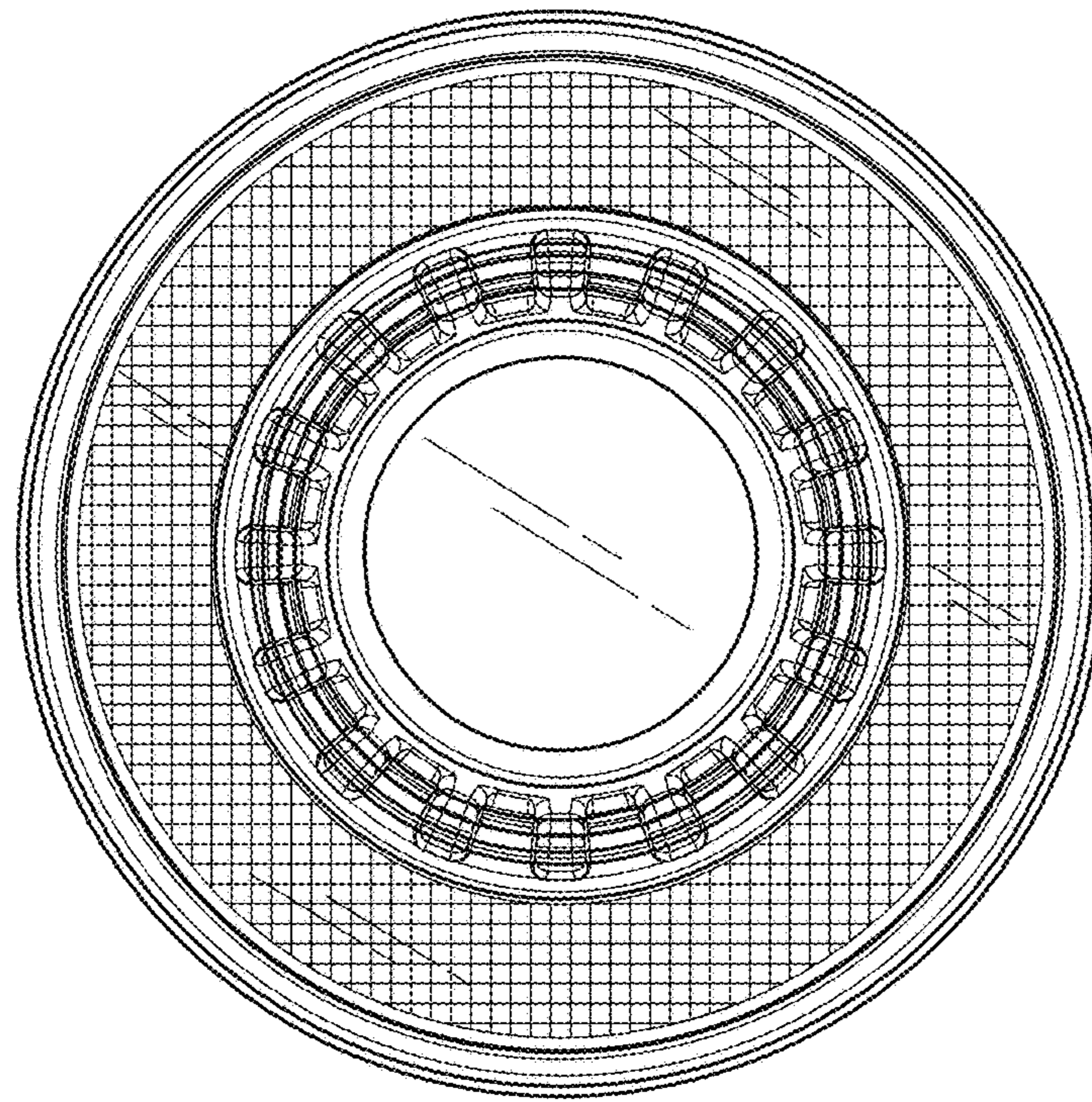

FIG. 2

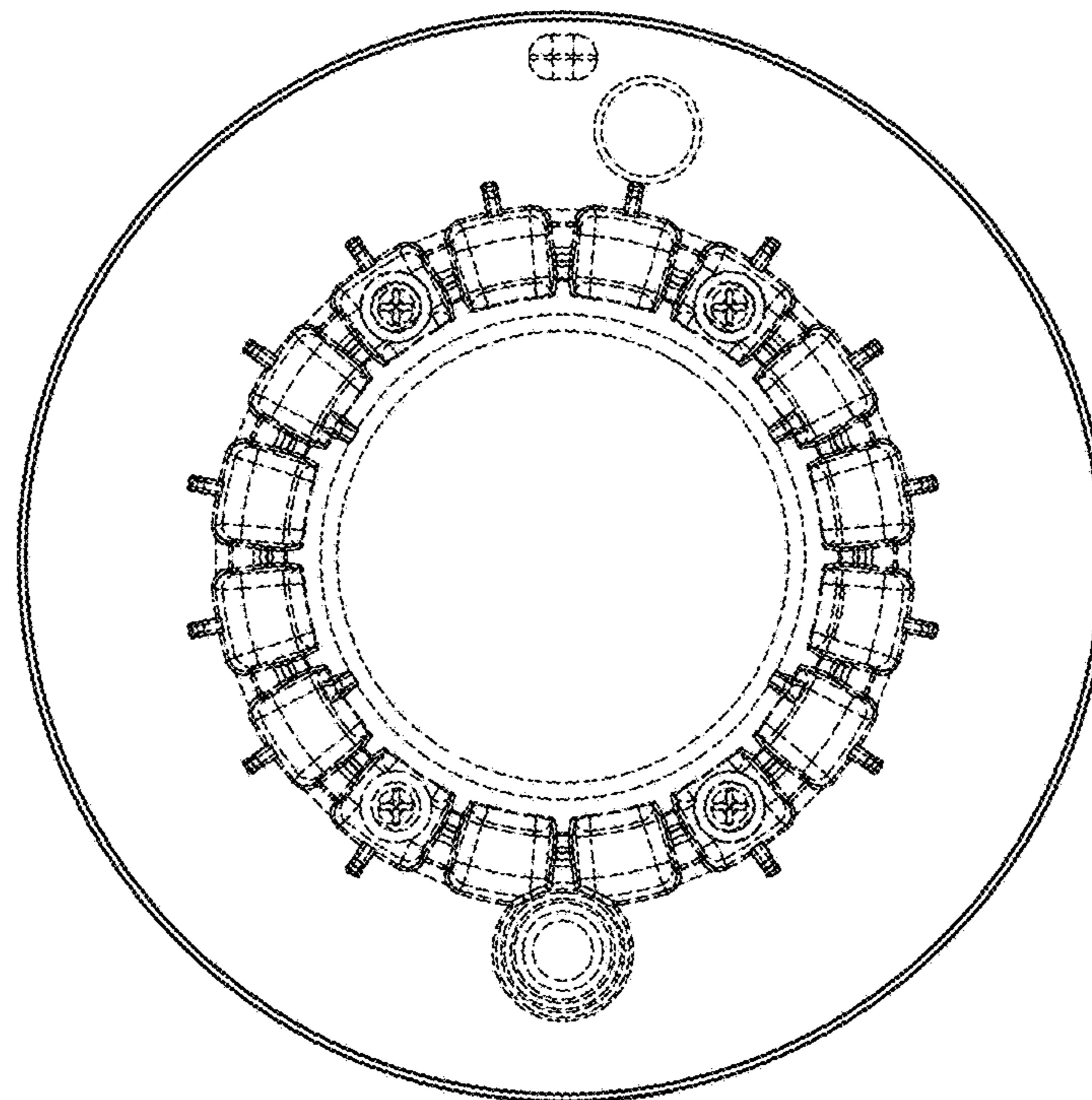

FIG. 3

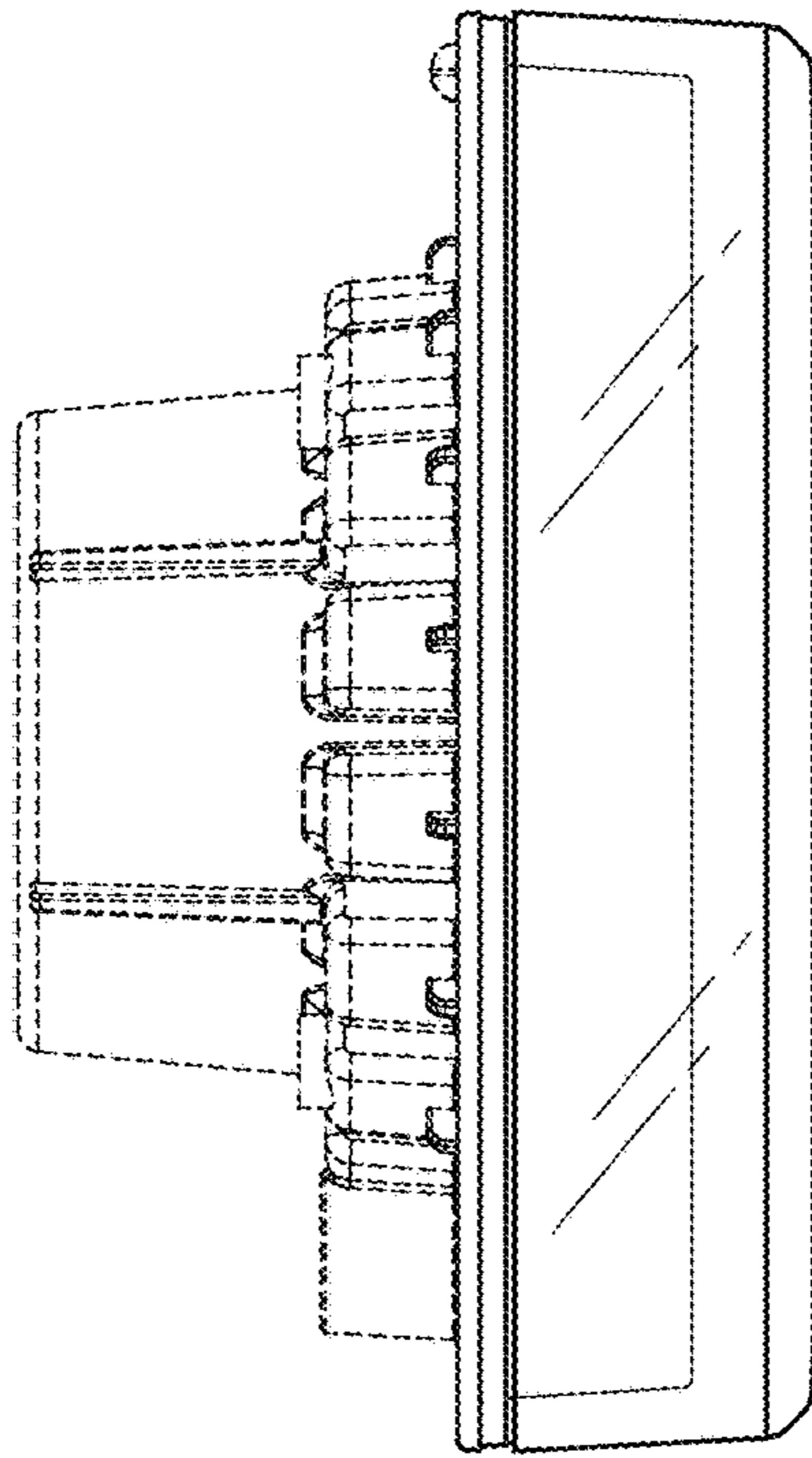

FIG. 4

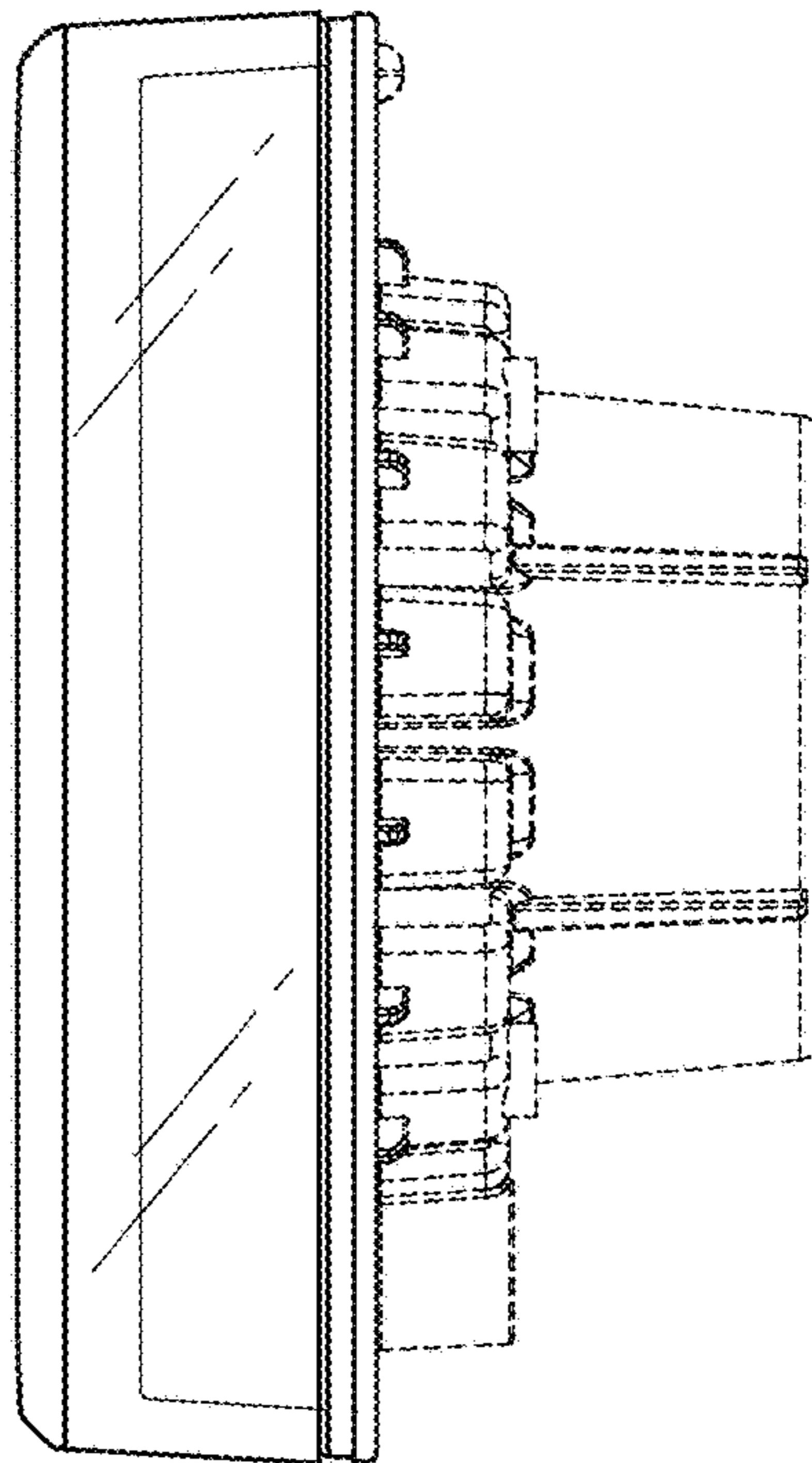

FIG. 5

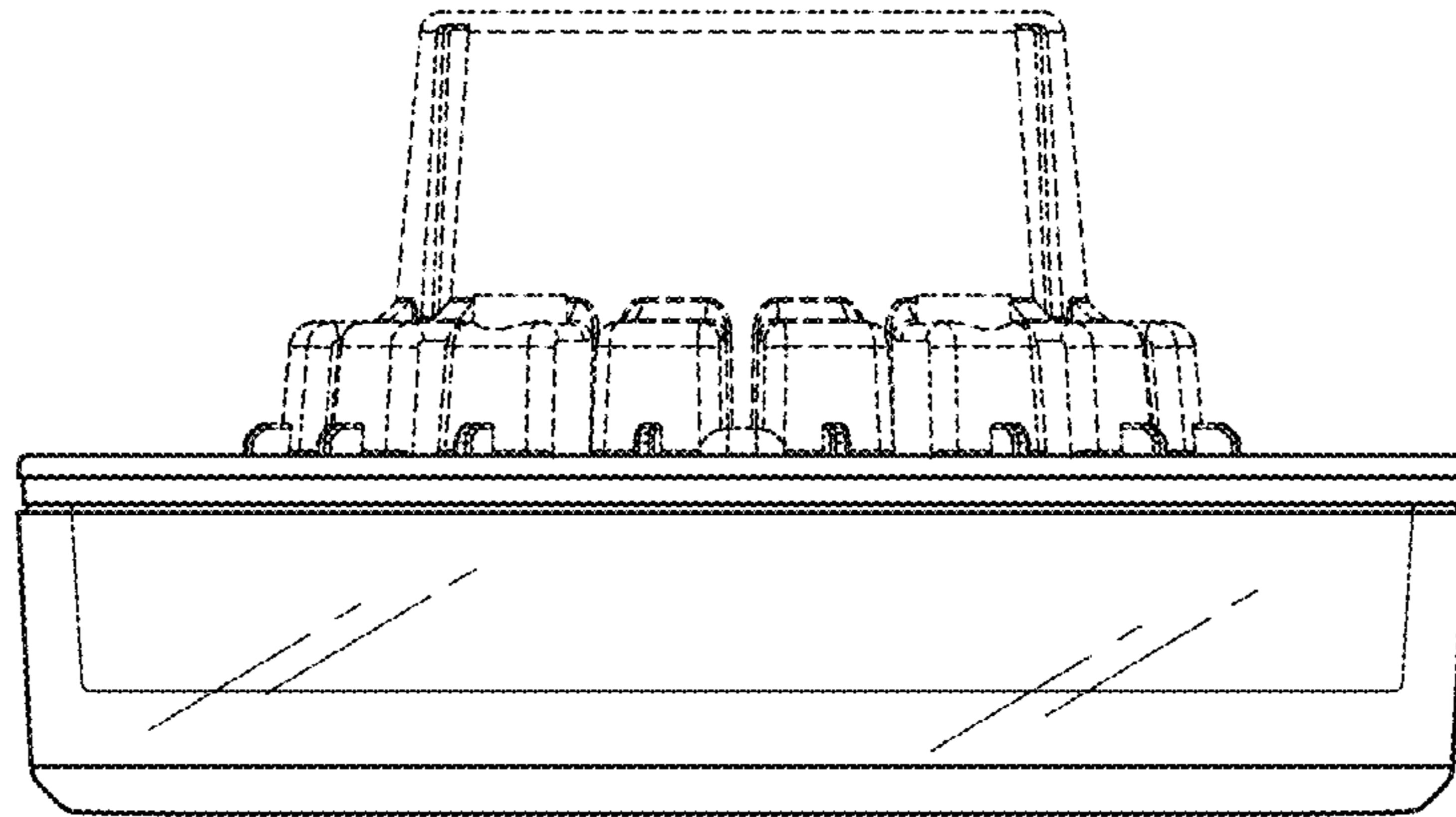

FIG. 6

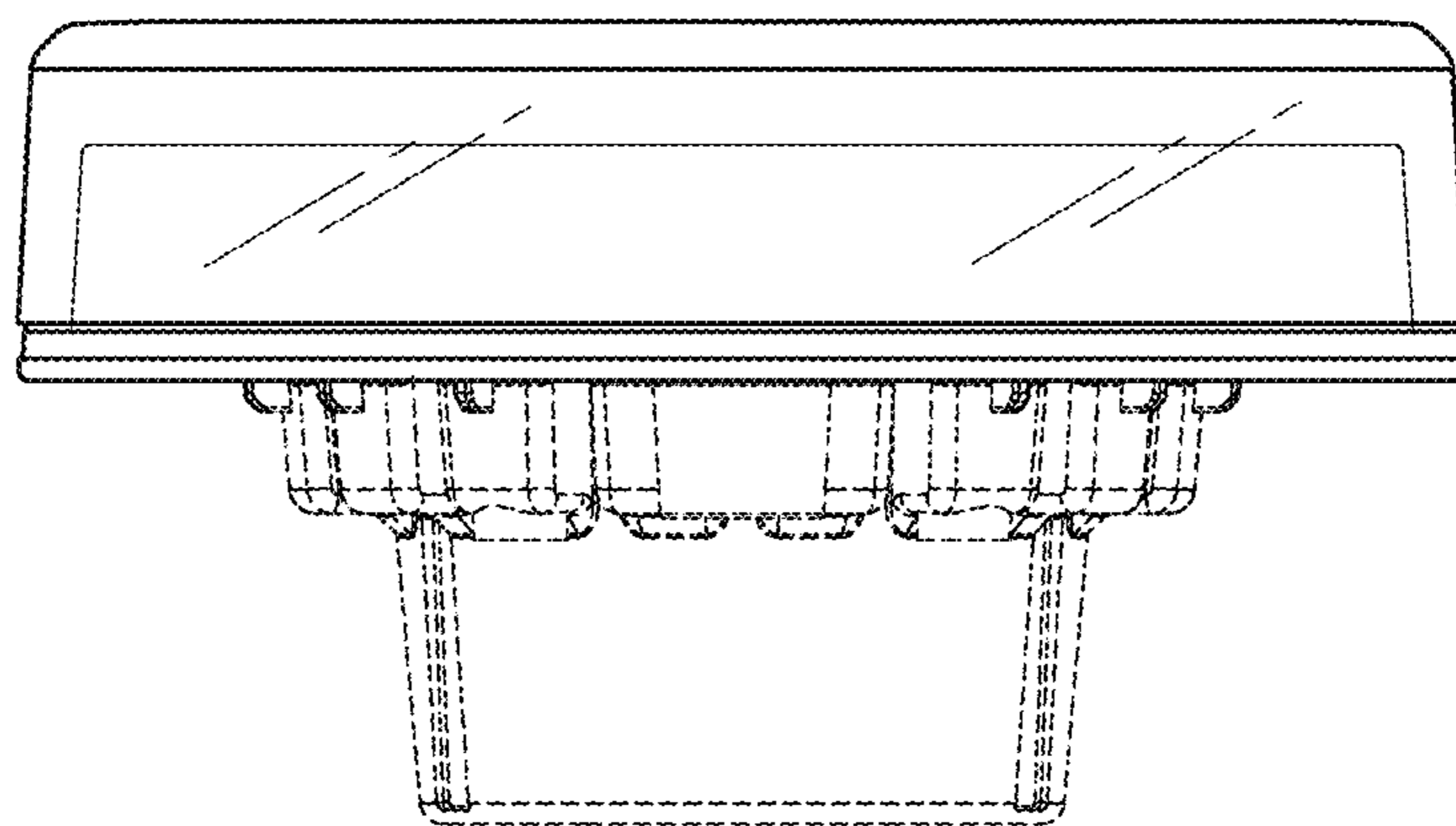

FIG. 7

UNITED STATES PATENT AND TRADEMARK OFFICE
CERTIFICATE OF CORRECTION

PATENT NO. : D792,991 S
APPLICATION NO. : 29/559900
DATED : July 25, 2017
INVENTOR(S) : Po-Hua Wu

Page 1 of 1

It is certified that error appears in the above-identified patent and that said Letters Patent is hereby corrected as shown below:

On the Title Page

Item (30) Foreign Application
Priority Data

Insert --Oct. 20, 2015
(TW).....104305834--

Item (57) CLAIM

Delete “vehicle tail light,”
Insert --vehicle taillight--

Item (57) DESCRIPTION

Delete “vehicle tail light,”
Insert --vehicle taillight--

Signed and Sealed this
Sixteenth Day of October, 2018

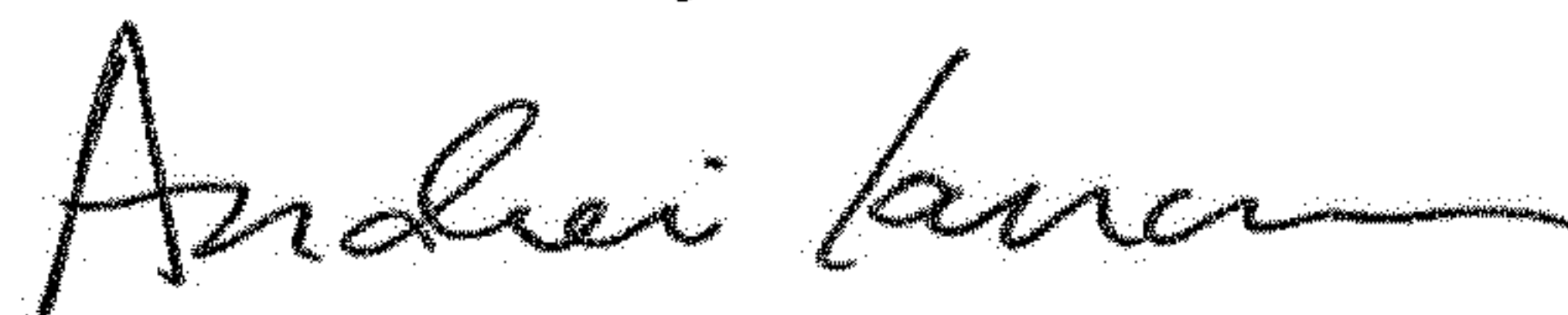

Andrei Iancu
Director of the United States Patent and Trademark Office